

**Diagonal 6mm (Type 1/3) CCD Image Sensor for EIA Black-and-White Video Camera**

**Description**

The ICX058CL is an interline CCD solid-state image sensor suitable for EIA black-and-white video cameras. Compared with the current product ICX058AL, sensitivity is improved drastically through the adoption of Super HAD CCD technology.

This chip features a field period readout system and an electronic shutter with variable charge-storage time.

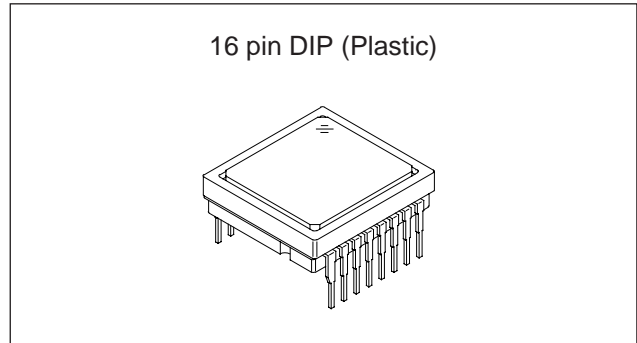

**Features**

- High sensitivity (+4dB at F8, +3dB at F1.2 compared with ICX058AL)
- High resolution, low smear and low dark current
- Excellent antiblooming characteristics
- Continuous variable-speed shutter
- Horizontal register: 5V drive
- Reset gate: 5V drive

**Device Structure**

- Interline CCD image sensor
- Image size: Diagonal 6mm (Type 1/3)
- Number of effective pixels: 768 (H) × 494 (V) approx. 380K pixels
- Number of total pixels: 811 (H) × 508 (V) approx. 410K pixels
- Chip size: 6.00mm (H) × 4.96mm (V)
- Unit cell size: 6.35μm (H) × 7.40μm (V)
- Optical black:
  - Horizontal (H) direction: Front 3 pixels, rear 40 pixels
  - Vertical (V) direction: Front 12 pixels, rear 2 pixels
- Number of dummy bits:
  - Horizontal 22
  - Vertical 1 (even field only)
- Substrate material: Silicon

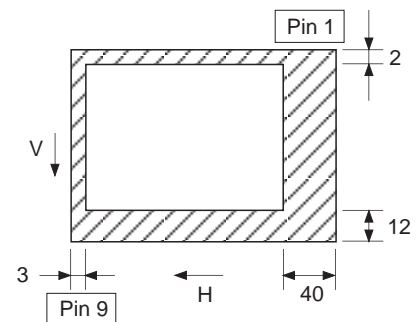

**Optical black position  
(Top View)**

**Super HAD CCD®**

\*Super HAD CCD is a registered trademark of Sony Corporation. Super HAD CCD is a CCD that drastically improves sensitivity by introducing newly developed semiconductor technology by Sony Corporation into Sony's high-performance HAD (Hole-Accumulation Diode) sensor.

Sony reserves the right to change products and specifications without prior notice. This information does not convey any license by any implication or otherwise under any patents or other right. Application circuits shown, if any, are typical examples illustrating the operation of the devices. Sony cannot assume responsibility for any problems arising out of the use of these circuits.

**Block Diagram and Pin Configuration**

(Top View)

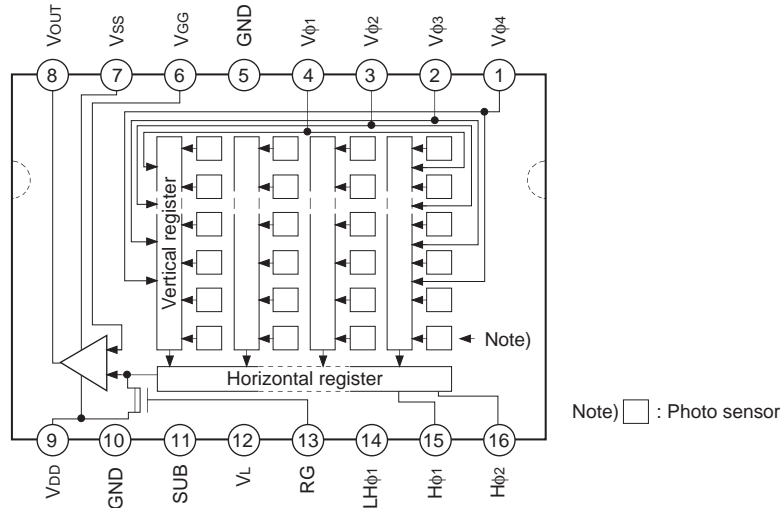

**Pin Description**

Pin No.	Symbol	Description	Pin No.	Symbol	Description
1	Vφ4	Vertical register transfer clock	9	VDD	Output amplifier drain supply
2	Vφ3	Vertical register transfer clock	10	GND	GND
3	Vφ2	Vertical register transfer clock	11	SUB	Substrate (Overflow drain)
4	Vφ1	Vertical register transfer clock	12	VL	Protective transistor bias
5	GND	GND	13	RG	Reset gate clock
6	VGG	Output amplifier gate bias	14	LHφ1	Horizontal register final stage transfer clock
7	VSS	Output amplifier source	15	Hφ1	Horizontal register transfer clock
8	VOUT	Signal output	16	Hφ2	Horizontal register transfer clock

**Absolute Maximum Ratings**

Item		Ratings	Unit	Remarks
Substrate voltage SUB – GND		-0.3 to +55	V	
Supply voltage	VDD, VOUT, VSS – GND	-0.3 to +18	V	
	VDD, VOUT, VSS – SUB	-55 to +10	V	
Vertical clock input voltage	Vφ1, Vφ2, Vφ3, Vφ4 – GND	-15 to +20	V	
	Vφ1, Vφ2, Vφ3, Vφ4 – SUB	to +10	V	
Voltage difference between vertical clock input pins		to +15	V	*1
Voltage difference between horizontal clock input pins		to +17	V	
Hφ1, Hφ2 – Vφ4		-17 to +17	V	
Hφ1, Hφ2, LHφ1, RG, VGG – GND		-10 to +15	V	
Hφ1, Hφ2, LHφ1, RG, VGG – SUB		-55 to +10	V	
VL – SUB		-65 to +0.3	V	
Vφ1, Vφ2, Vφ3, Vφ4, VDD, VOUT – VL		-0.3 to +30	V	
RG – VL		-0.3 to +24	V	
VGG, VSS, Hφ1, Hφ2, LHφ1 – VL		-0.3 to +20	V	
Storage temperature		-30 to +80	°C	
Operating temperature		-10 to +60	°C	

\*1 +27V (Max.) when clock width < 10μs, clock duty factor < 0.1%.



## Clock Voltage Conditions

Item	Symbol	Min.	Typ.	Max.	Unit	Waveform diagram	Remarks
Readout clock voltage	$V_{VT}$	14.55	15.0	15.45	V	1	
Vertical transfer clock voltage	$V_{VH1}, V_{VH2}$	-0.05	0	0.05	V	2	$V_{VH} = (V_{VH1} + V_{VH2})/2$
	$V_{VH3}, V_{VH4}$	-0.2	0	0.05	V	2	
	$V_{VL1}, V_{VL2}, V_{VL3}, V_{VL4}$	-9.0	-8.5	-8.0	V	2	$V_{VL} = (V_{VL3} + V_{VL4})/2$
	$V_{\phi V}$	7.8	8.5	9.05	V	2	$V_{\phi V} = V_{VHn} - V_{VLn} (n = 1 \text{ to } 4)$
	$ V_{VH1} - V_{VH2} $			0.1	V	2	
	$V_{VH3} - V_{VH}$	-0.25		0.1	V	2	
	$V_{VH4} - V_{VH}$	-0.25		0.1	V	2	
	$V_{VHH}$			0.5	V	2	High-level coupling
	$V_{VHL}$			0.5	V	2	High-level coupling
	$V_{V LH}$			0.5	V	2	Low-level coupling
	$V_{VLL}$			0.5	V	2	Low-level coupling
Horizontal transfer clock voltage	$V_{\phi H}, V_{\phi LH}$	4.75	5.0	5.25	V	3	*5
	$V_{HL}, V_{LHL}$	-0.05	0	0.05	V	3	*5
Reset gate clock voltage	$V_{\phi RG}$	4.5	5.0	5.5	V	4	*6
	$V_{RGLH} - V_{RGLL}$			0.8	V	4	Low-level coupling
Substrate clock voltage	$V_{\phi SUB}$	22.5	23.5	24.5	V	5	

\*5 The horizontal final stage transfer clock input pin  $LH\phi_1$  is connected to the horizontal transfer clock input pin  $H\phi_1$ .

\*6 The reset gate clock voltage need not be adjusted when reset gate clock is driven when the specifications are as given below. In this case, the reset gate clock voltage setting indicated on the back of the image sensor has not significance.

Item	Symbol	Min.	Typ.	Max.	Unit	Waveform diagram	Remarks
Reset gate clock voltage	$V_{RGL}$	-0.2	0	0.2	V	4	
	$V_{\phi RG}$	8.5	9.0	9.5	V	4	

**Clock Equivalent Circuit Constant**

Item	Symbol	Min.	Typ.	Max.	Unit	Remarks
Capacitance between vertical transfer clock and GND	$C\phi V1, C\phi V3$		1000		pF	
	$C\phi V2, C\phi V4$		560		pF	
Capacitance between vertical transfer clocks	$C\phi V12, C\phi V34$		470		pF	
	$C\phi V23, C\phi V41$		330		pF	
	$C\phi V13$		220		pF	
	$C\phi V24$		100		pF	
Capacitance between horizontal transfer clock and GND	$C\phi H1, C\phi H2$		47		pF	
Capacitance between horizontal transfer clocks	$C\phi HH$		43		pF	
Capacitance between horizontal final stage transfer clock and GND	$C\phi LH$		8		pF	
Capacitance between reset gate clock and GND	$C\phi RG$		8		pF	
Capacitance between substrate clock and GND	$C\phi SUB$		270		pF	
Vertical transfer clock series resistor	$R1, R2, R3, R4$		80		$\Omega$	
Vertical transfer clock ground resistor	$R_{GND}$		15		$\Omega$	
Horizontal transfer clock series resistor	$R\phi H$		15		$\Omega$	

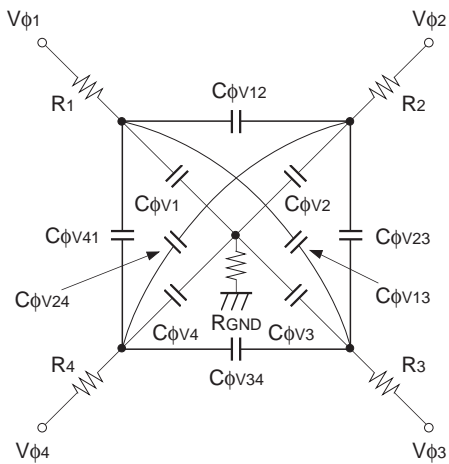

**Vertical transfer clock equivalent circuit**

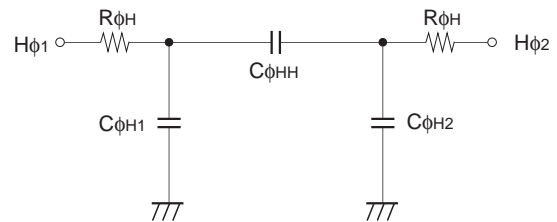

**Horizontal transfer clock equivalent circuit**

Drive Clock Waveform Conditions

(1) Readout clock waveform

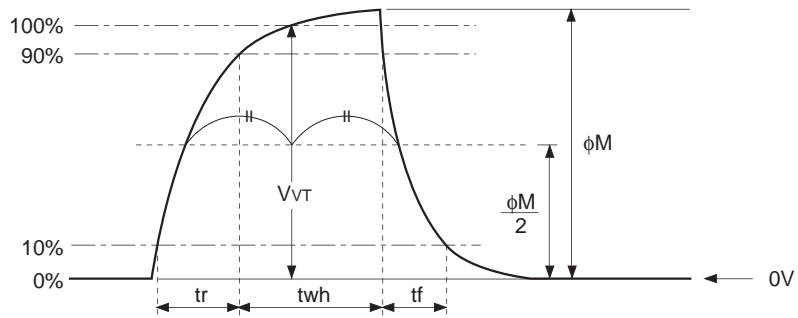

(2) Vertical transfer clock waveform

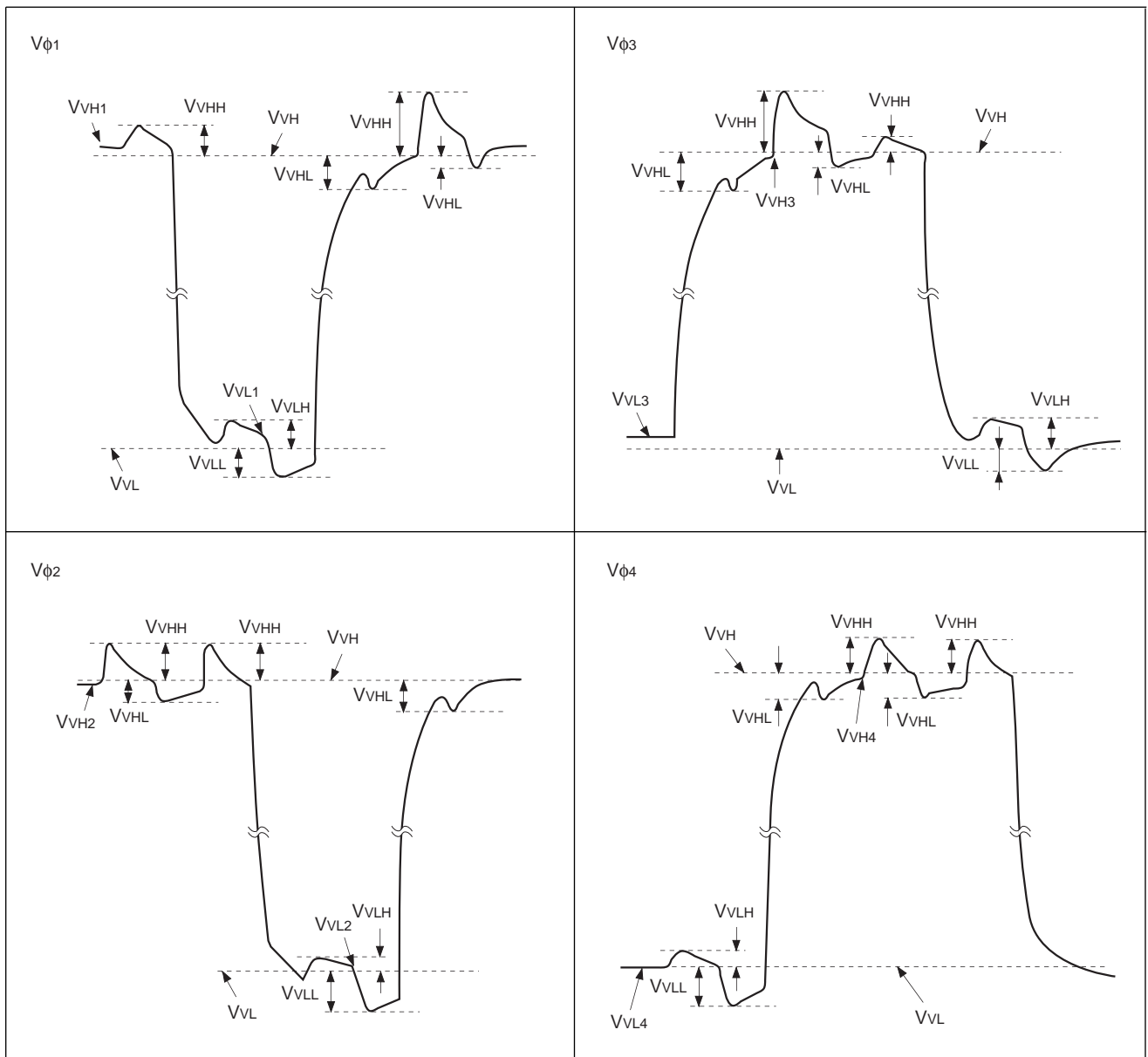

$$V_{VH} = (V_{VH1} + V_{VH2})/2$$

$$V_{VL} = (V_{VLL3} + V_{VLL4})/2$$

$$V_{\phi V} = V_{VHn} - V_{VVLn} \quad (n = 1 \text{ to } 4)$$

**(3) Horizontal transfer clock waveform**

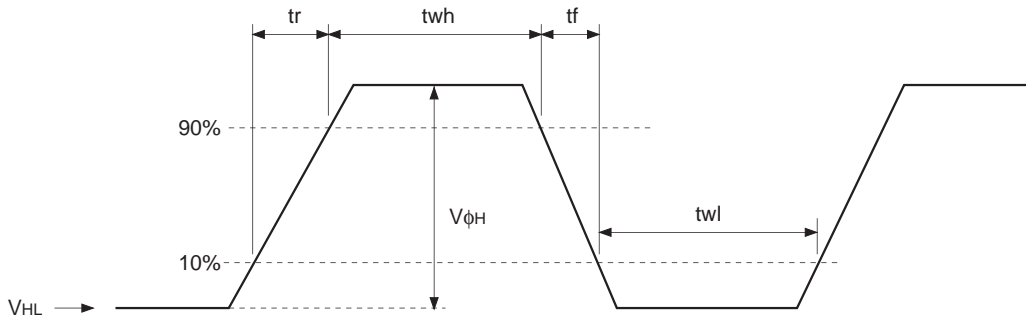

**(4) Reset gate clock waveform**

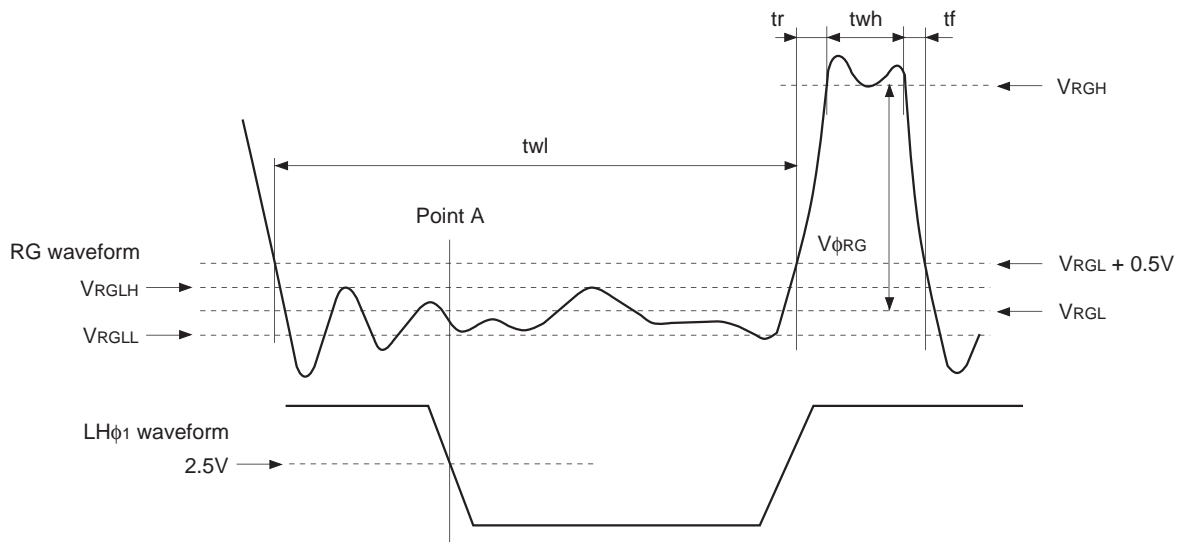

$V_{RGLH}$  is the maximum value and  $V_{RGLL}$  is the minimum value of the coupling waveform during the period from Point A in the above diagram until the rising edge of RG.

In addition,  $V_{RGL}$  is the average value of  $V_{RGLH}$  and  $V_{RGLL}$ .

$$V_{RGL} = (V_{RGLH} + V_{RGLL})/2$$

Assuming  $V_{RGH}$  is the minimum value during the interval  $t_{wh}$ , then:

$$V_{\phi RG} = V_{RGH} - V_{RGL}$$

(5) Substrate clock waveform

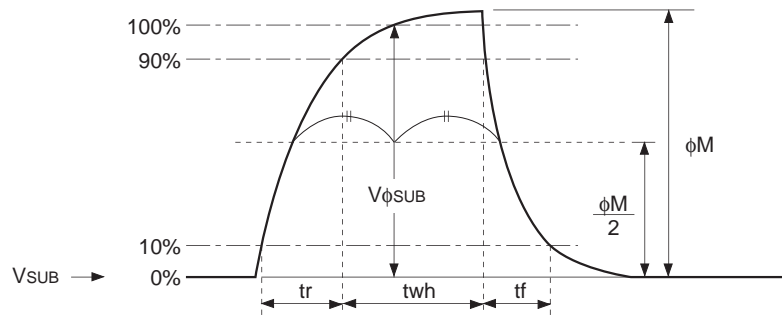

**Clock Switching Characteristics**

**Note)** Because the horizontal final stage transfer clock LHφ<sub>1</sub> is connected to the horizontal transfer clock Hφ<sub>1</sub>, specifications will be the same as Hφ<sub>1</sub>.

Item	Symbol	twh			twl			tr			tf			Unit	Remarks
		Min.	Typ.	Max.	Min.	Typ.	Max.	Min.	Typ.	Max.	Min.	Typ.	Max.		
Readout clock	V <sub>T</sub>	2.3	2.5						0.5			0.5		μs	During readout
Vertical transfer clock	Vφ <sub>1</sub> , Vφ <sub>2</sub> , Vφ <sub>3</sub> , Vφ <sub>4</sub>										15		250	ns	*1
Horizontal transfer clock	During imaging	Hφ <sub>1</sub> , LHφ <sub>1</sub>	18	24		19.5	26		10	17.5		10	17.5	ns	*2
		Hφ <sub>2</sub>	21	26		19	24		10	15		10	15		
	During parallel-serial conversion	Hφ <sub>1</sub> , LHφ <sub>1</sub>		5.38					0.01			0.01		μs	
		Hφ <sub>2</sub>					5.38		0.01			0.01			
Reset gate clock	φ <sub>RG</sub>	11	13			51		3			3		ns		
Substrate clock	φ <sub>SUB</sub>	1.5	1.8						0.5			0.5	μs	During drain charge	

\*1 When vertical transfer clock driver CXD1267AN is used.

\*2  $t_f \geq t_r - 2ns$ , and the cross-point voltage ( $V_{CR}$ ) for the Hφ<sub>1</sub> · LHφ<sub>1</sub> rising side of the Hφ<sub>1</sub> · LHφ<sub>1</sub> and Hφ<sub>2</sub> waveforms must be at least 2.5V.

Item	Symbol	two			Unit	Remarks
		Min.	Typ.	Max.		
Horizontal transfer clock	Hφ <sub>1</sub> · LHφ <sub>1</sub> , Hφ <sub>2</sub>	16	20		ns	*3

\*3 The overlap period for twh and twl of horizontal transfer clocks Hφ<sub>1</sub> · LHφ<sub>1</sub> and Hφ<sub>2</sub> is two.

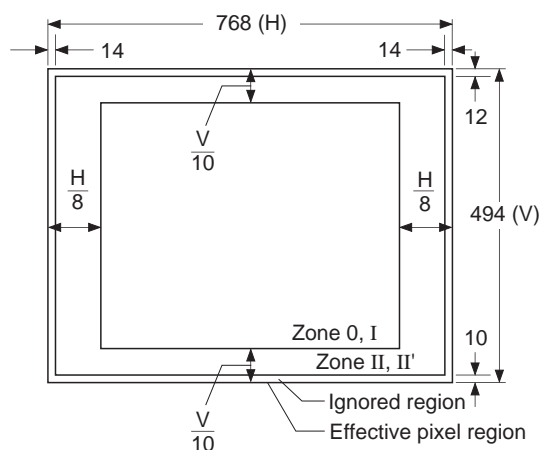

Image Sensor Characteristics

(Ta = 25°C)

Item	Symbol	Min.	Typ.	Max.	Unit	Measurement method	Remarks
Sensitivity	S	360	460		mV	1	
Saturation signal	Vsat	600			mV	2	Ta = 60°C
Smear	Sm		0.002	0.007	%	3	
Video signal shading	SH			20	%	4	Zone 0 and I
				25	%	4	Zone 0 to II'
Dark signal	Vdt			2	mV	5	Ta = 60°C
Dark signal shading	$\Delta Vdt$			1	mV	6	Ta = 60°C
Flicker	F			2	%	7	
Lag	Lag			0.5	%	8	

Zone Definition of Video Signal Shading



## Image Sensor Characteristics Measurement Method

### ◎ Measurement conditions

- 1) In the following measurements, the substrate voltage and the reset gate clock voltage are set to the values indicated on the device, and the device drive conditions are at the typical values of the bias and clock voltage conditions.
- 2) In the following measurements, spot blemishes are excluded and, unless otherwise specified, the optical black (OB) level is used as the reference for the signal output, and the value measured at point [\*A] in the drive circuit example is used.

### ◎ Definition of standard imaging conditions

- 1) Standard imaging condition I:  
Use a pattern box (luminance 706cd/m<sup>2</sup>, color temperature of 3200K halogen source) as a subject. (Pattern for evaluation is not applicable.) Use a testing standard lens with CM500S (t = 1.0mm) as an IR cut filter and image at F8. The luminous intensity to the sensor receiving surface at this point is defined as the standard sensitivity testing luminous intensity.
- 2) Standard imaging condition II:  
Image a light source (color temperature of 3200K) with a uniformity of brightness within 2% at all angles. Use a testing standard lens with CM500S (t = 1.0mm) as an IR cut filter. The luminous intensity is adjusted to the value indicated in each testing item by the lens diaphragm.

#### 1. Sensitivity

Set to standard imaging condition I. After selecting the electronic shutter mode with a shutter speed of 1/250s, measure the signal output (Vs) at the center of the screen and substitute the value into the following formula.

$$S = V_s \times \frac{250}{60} \text{ [mV]}$$

#### 2. Saturation signal

Set to standard imaging condition II. After adjusting the luminous intensity to 10 times the intensity with average value of the signal output, 200mV, measure the minimum value of the signal output.

#### 3. Smear

Set to standard imaging condition II. With the lens diaphragm at F5.6 to F8, adjust the luminous intensity to 500 times the intensity with average value of the signal output, 200mV. When the readout clock is stopped and the charge drain is executed by the electronic shutter at the respective H blankings, measure the maximum value VSm [mV] of the signal output and substitute the value into the following formula.

$$S_m = \frac{V_{Sm}}{200} \times \frac{1}{500} \times \frac{1}{10} \times 100 \text{ [%]} \text{ (1/10V method conversion value)}$$

#### 4. Video signal shading

Set to standard imaging condition II. With the lens diaphragm at F5.6 to F8, adjust the luminous intensity so that the average value of the signal output is 200mV. Then measure the maximum (Vmax [mV]) and minimum (Vmin [mV]) values of the signal output and substitute the values into the following formula.

$$SH = (V_{max} - V_{min})/200 \times 100 \text{ [%]}$$

#### 5. Dark signal

Measure the average value of the signal output (Vdt [mV]) with the device ambient temperature 60°C and the device in the light-obstructed state, using the horizontal idle transfer level as a reference.

## 6. Dark signal shading

After measuring 5, measure the maximum ( $V_{dmax}$  [mV]) and minimum ( $V_{dmin}$  [mV]) values of the dark signal output and substitute the values into the following formula.

$$\Delta V_{dt} = V_{dmax} - V_{dmin} \text{ [mV]}$$

## 7. Flicker

Set to standard imaging condition II. Adjust the luminous intensity so that the average value of the signal output is 200mV, and then measure the difference in the signal level between fields ( $\Delta V_f$  [mV]). Then substitute the value into the following formula.

$$F = (\Delta V_f / 200) \times 100 \text{ [%]}$$

## 8. Lag

Adjust the signal output value generated by strobe light to 200mV. After setting the strobe light so that it strobos with the following timing, measure the residual signal ( $V_{lag}$ ). Substitute the value into the following formula.

$$\text{Lag} = (V_{lag} / 200) \times 100 \text{ [%]}$$

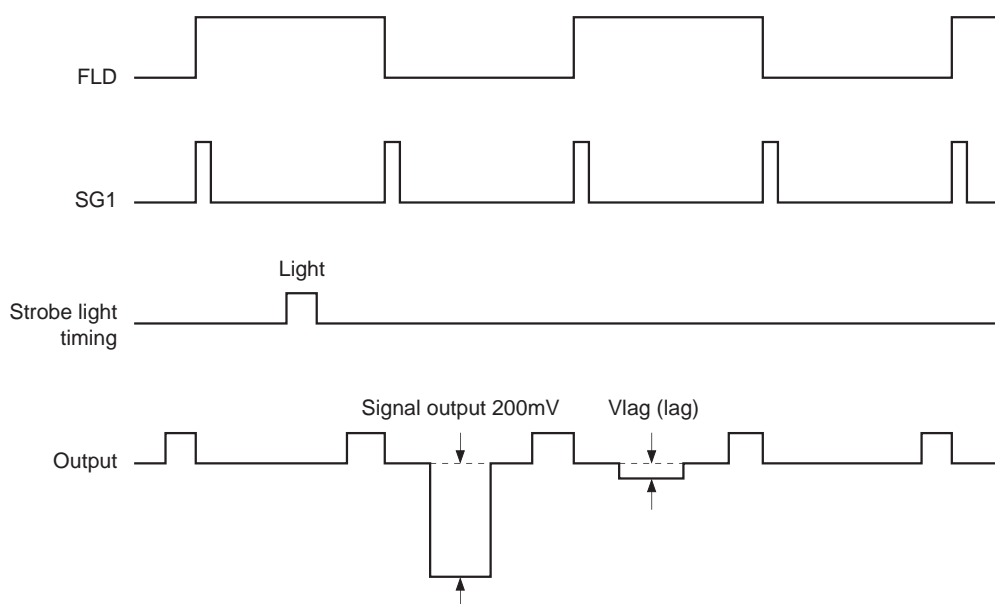

Drive Circuit

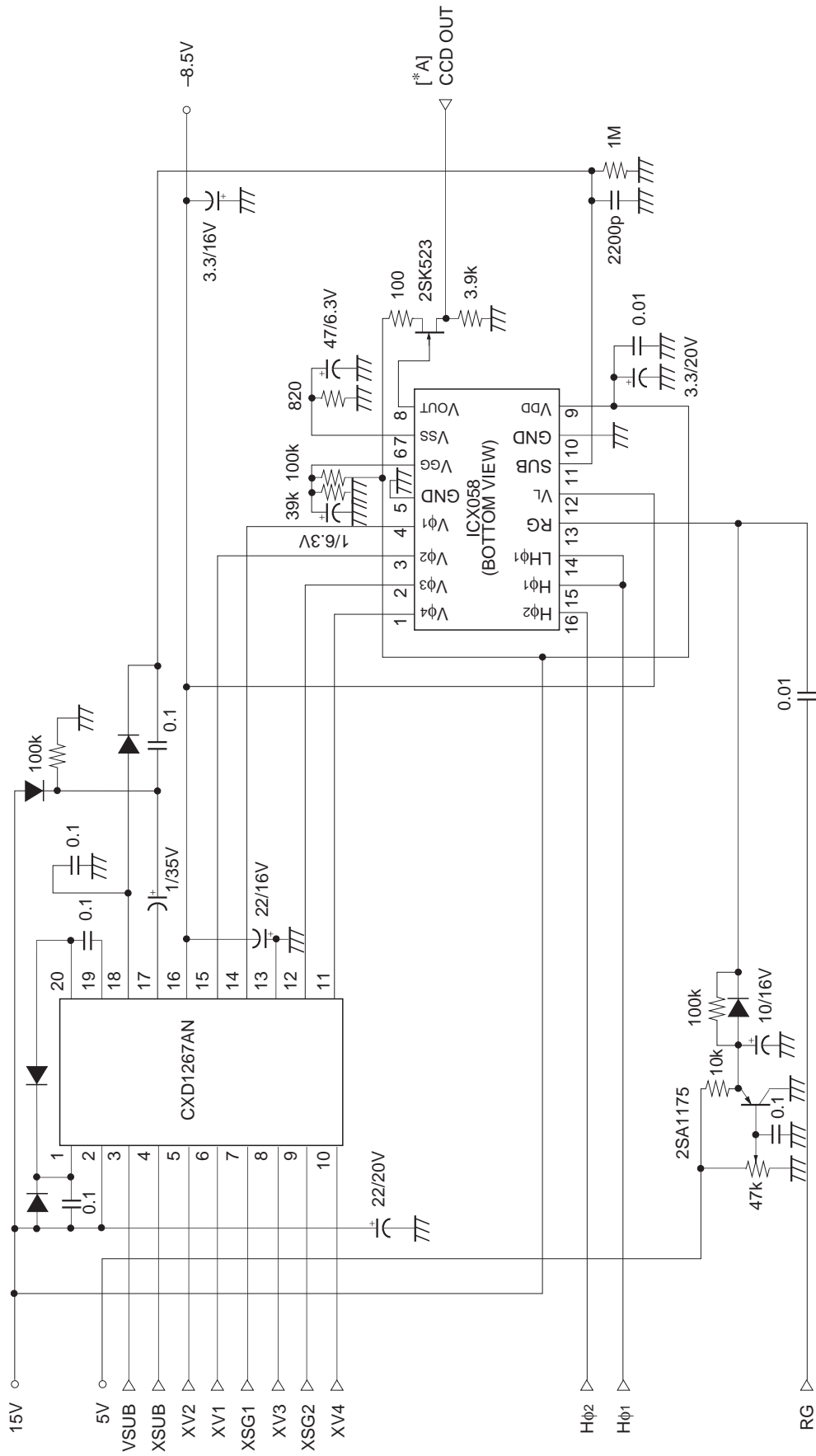

**Spectral Sensitivity Characteristics**

(Includes lens characteristics, excludes light source characteristics)

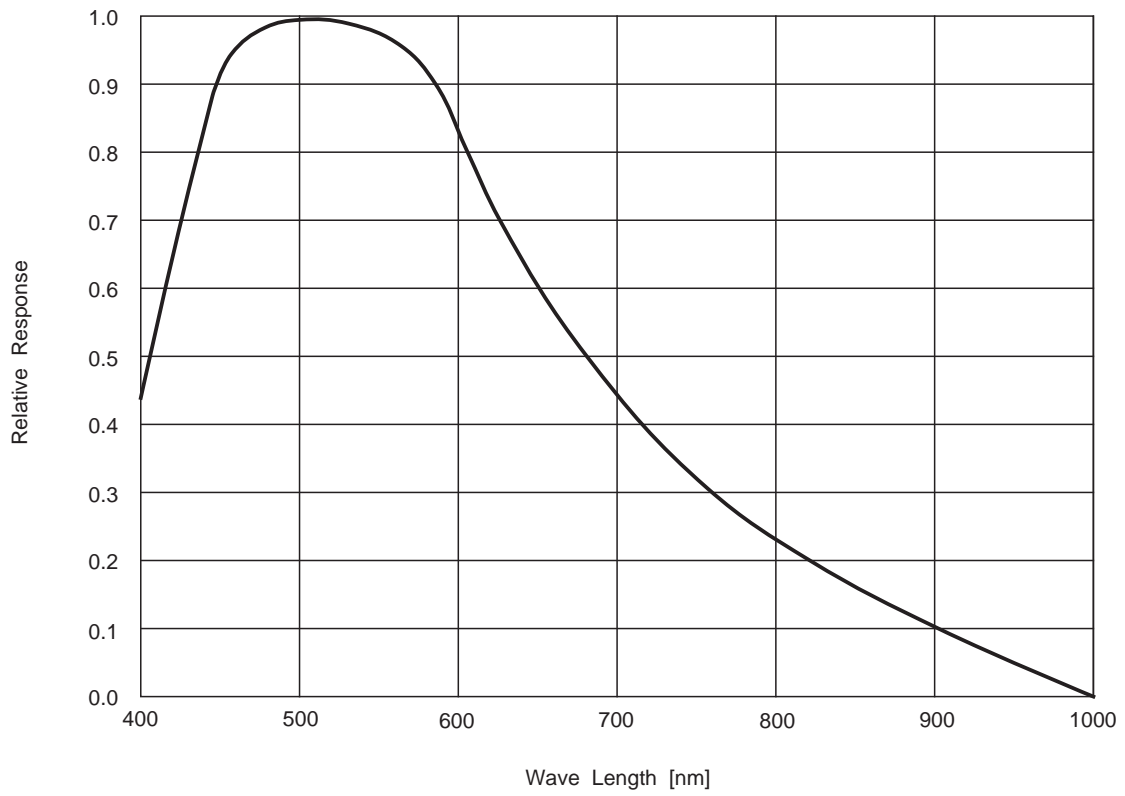

**Sensor Readout Clock Timing Chart**

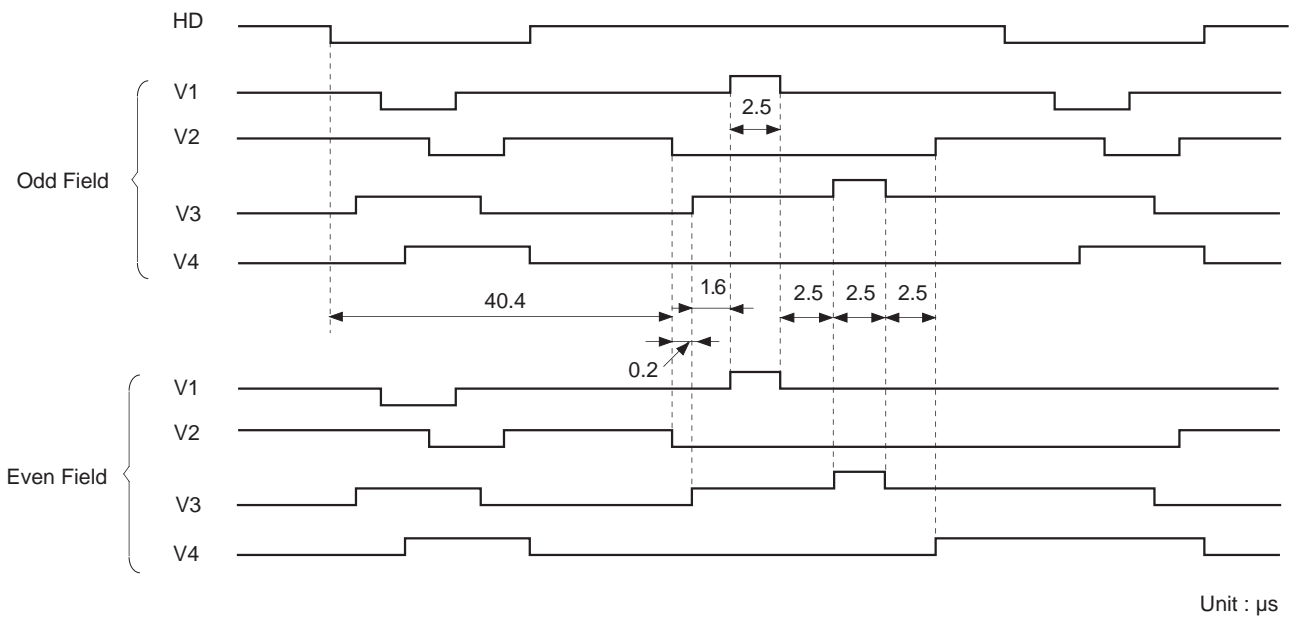

Drive Timing Chart (Vertical Sync)

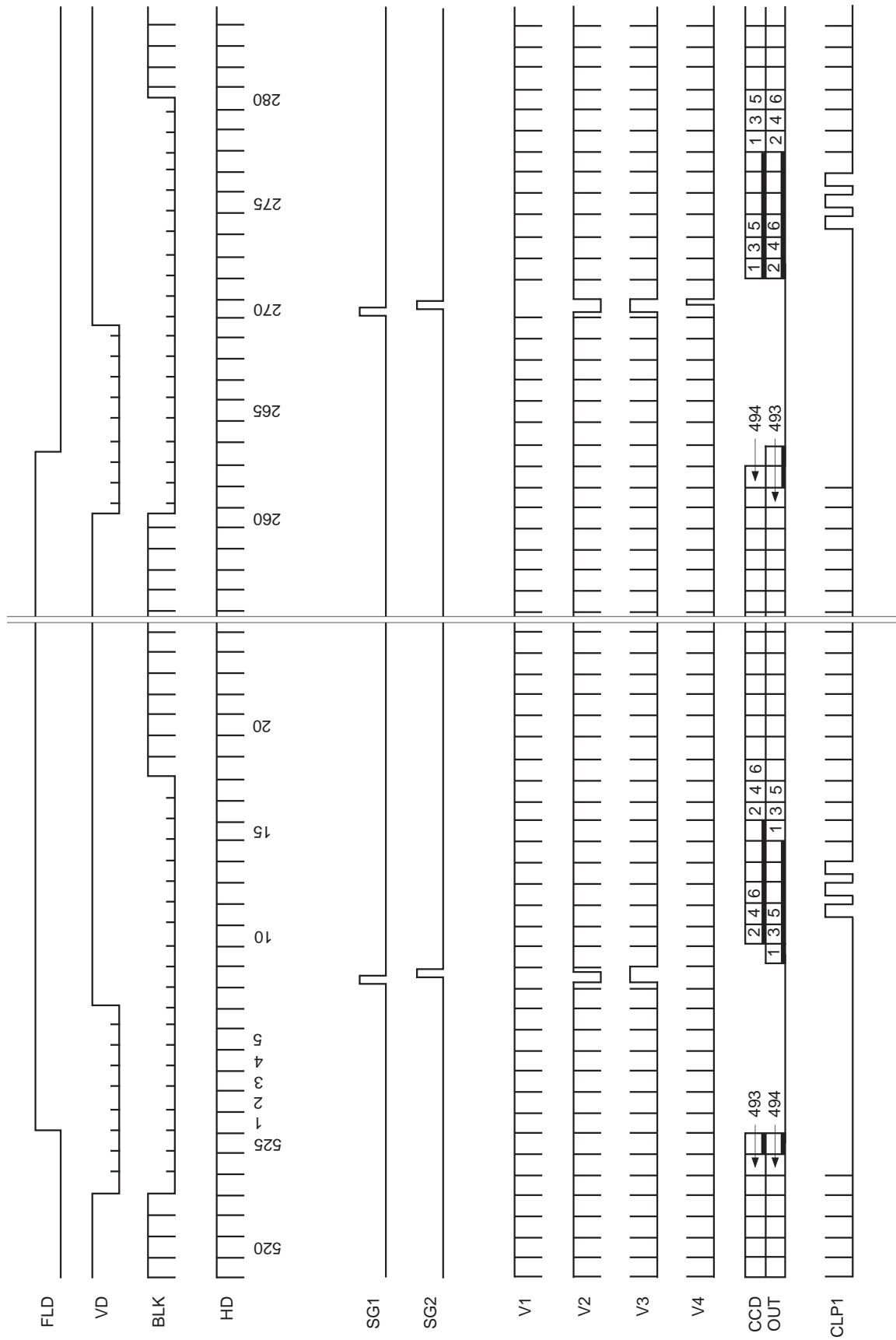

Drive Timing Chart (Horizontal Sync)

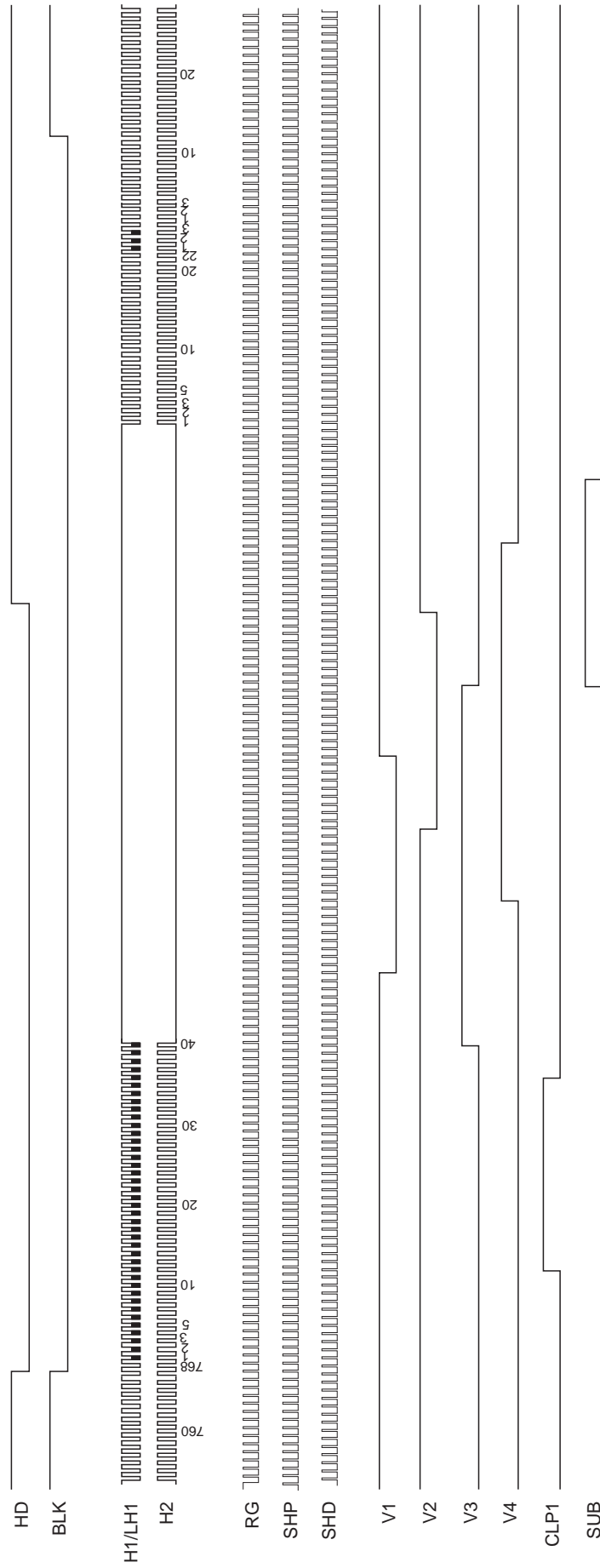

## Notes on Handling

### 1) Static charge prevention

CCD image sensors are easily damaged by static discharge. Before handling be sure to take the following protective measures.

- Either handle bare handed or use non-chargeable gloves, clothes or material.  
Also use conductive shoes.
- When handling directly use an earth band.
- Install a conductive mat on the floor or working table to prevent the generation of static electricity.
- Ionized air is recommended for discharge when handling CCD image sensor.
- For the shipment of mounted substrates, use boxes treated for the prevention of static charges.

### 2) Soldering

- Make sure the package temperature does not exceed 80°C.
- Solder dipping in a mounting furnace causes damage to the glass and other defects. Use a ground 30W soldering iron and solder each pin in less than 2 seconds. For repairs and remount, cool sufficiently.
- To dismount an image sensor, do not use a solder suction equipment. When using an electric desoldering tool, use a thermal controller of the zero cross On/Off type and connect it to ground.

### 3) Dust and dirt protection

Image sensors are packed and delivered by taking care of protecting its glass plates from harmful dust and dirt. Clean glass plates with the following operation as required, and use them.

- Perform all assembly operations in a clean room (class 1000 or less).
- Do not either touch glass plates by hand or have any object come in contact with glass surfaces. Should dirt stick to a glass surface, blow it off with an air blower. (For dirt stuck through static electricity ionized air is recommended.)
- Clean with a cotton bud and ethyl alcohol if the grease stained. Be careful not to scratch the glass.
- Keep in a case to protect from dust and dirt. To prevent dew condensation, preheat or precool when moving to a room with great temperature differences.
- When a protective tape is applied before shipping, just before use remove the tape applied for electrostatic protection. Do not reuse the tape.

### 4) Installing (attaching)

- Remain within the following limits when applying a static load to the package. Do not apply any load more than 0.7mm inside the outer perimeter of the glass portion, and do not apply any load or impact to limited portions. (This may cause cracks in the package.)

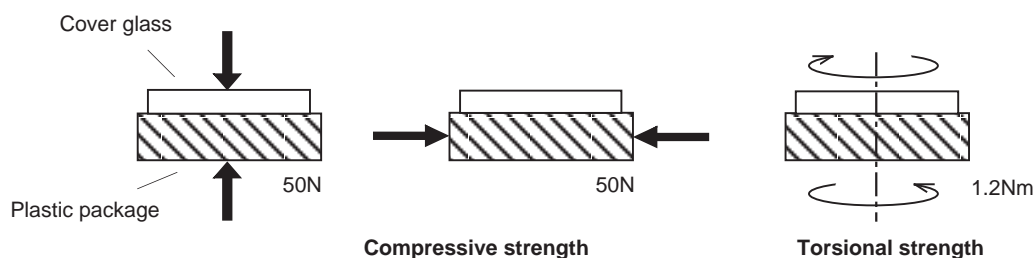

- If a load is applied to the entire surface by a hard component, bending stress may be generated and the package may fracture, etc., depending on the flatness of the bottom of the package. Therefore, for installation, use either an elastic load, such as a spring plate, or an adhesive.



- c) The adhesive may cause the marking on the rear surface to disappear, especially in case the regulated voltage value is indicated on the rear surface. Therefore, the adhesive should not be applied to this area, and indicated values should be transferred to the other locations as a precaution.
- d) The notch of the package is used for directional index, and that can not be used for reference of fixing. In addition, the cover glass and seal resin may overlap with the notch of the package.
- e) If the lead bend repeatedly and the metal, etc., clash or rub against the package, the dust may be generated by the fragments of resin.
- f) Acrylate anaerobic adhesives are generally used to attach CCD image sensors. In addition, cyanoacrylate instantaneous adhesives are sometimes used jointly with acrylate anaerobic adhesives. (reference)

#### 5) Others

- a) Do not expose to strong light (sun rays) for long periods. For continuous using under cruel condition exceeding the normal using condition, consult our company.
- b) Exposure to high temperature or humidity will affect the characteristics. Accordingly avoid storage or usage in such conditions.
- c) The brown stain may be seen on the bottom or side of the package. But this does not affect the CCD characteristics.

Package Outline Unit: mm

16pin DIP (450mil)

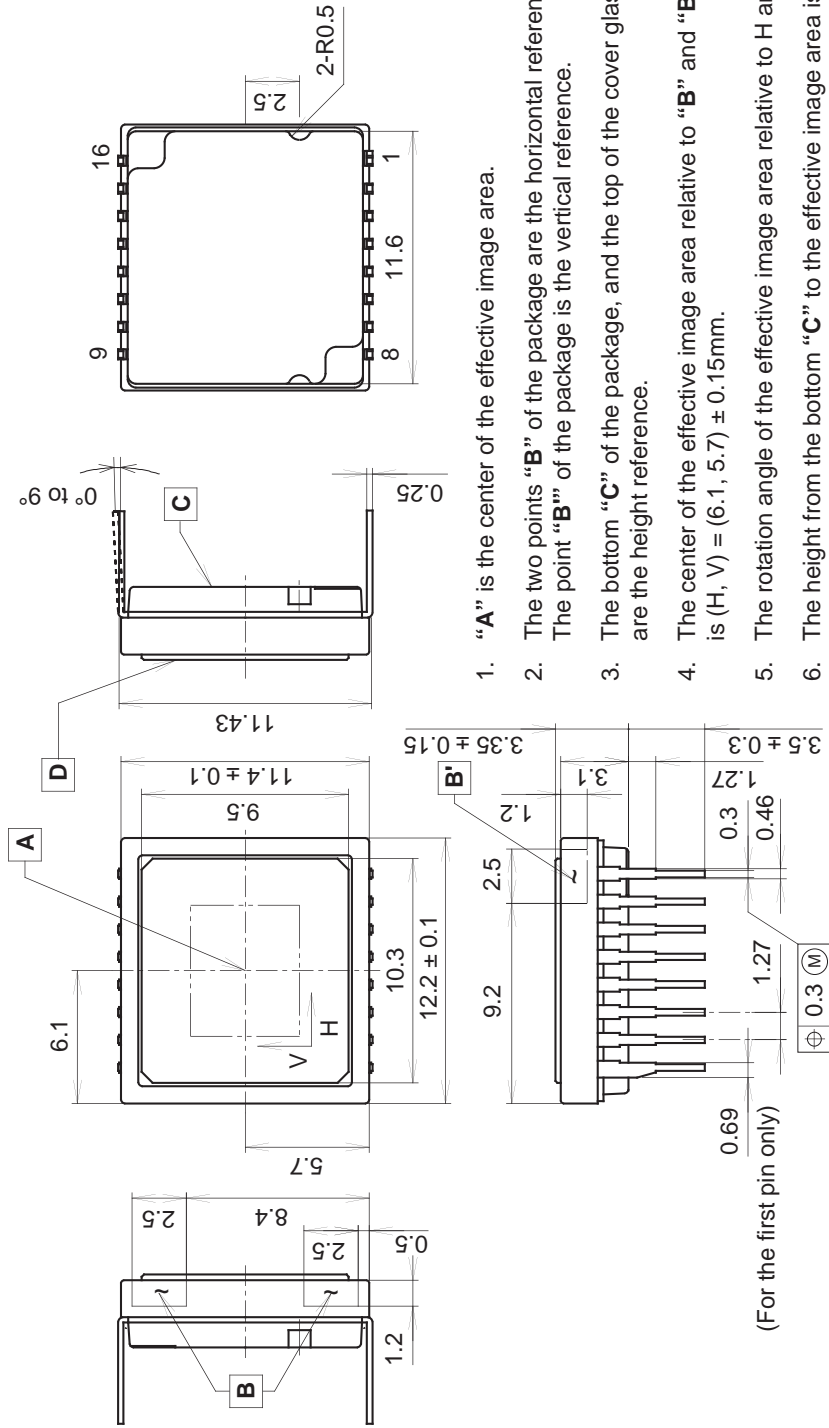

1. "A" is the center of the effective image area.
2. The two points "B" of the package are the horizontal reference. The point "B" of the package is the vertical reference.
3. The bottom "C" of the package, and the top of the cover glass "D" are the height reference.
4. The center of the effective image area relative to "B" and "B" is (H, V) = (6.1, 5.7) ± 0.15mm.
5. The rotation angle of the effective image area relative to H and V is ± 1°.
6. The height from the bottom "C" to the effective image area is 1.41 ± 0.10mm. The height from the top of the cover glass "D" to the effective image area is 1.94 ± 0.15mm.
7. The tilt of the effective image area relative to the bottom "C" is less than 50µm. The tilt of the effective image area relative to the top "D" of the cover glass is less than 50µm.
8. The thickness of the cover glass is 0.75mm, and the refractive index is 1.5.
9. The notches on the bottom of the package are used only for directional index, they must not be used for reference of fixing.

PACKAGE STRUCTURE

PACKAGE MATERIAL	Plastic
LEAD TREATMENT	GOLD PLATING
LEAD MATERIAL	42 ALLOY
PACKAGE WEIGHT	0.9g