



TRIACS

- GLASS PASSIVATED CHIP
- I_GT SPECIFIED IN FOUR QUADRANTS

ADVANTAGES

- EXCELLENT (dv/dt)_C : > 10 V/μs
- METALLIC ENCAPSULATION GIVES AN EXCELLENT THERMAL IMPEDANCE AND HIGH RELIABILITY CONSTRUCTION

APPLICATIONS

- MOTOR CONTROL
- HEATING CONTROL
- LIGHT DIMMER

DESCRIPTION

Power triacs suited for use on 220 V and 380 V main.

Thread : 1/4" -28 UNF : type N⁺
M6 on request : type N⁺ + suffix M



TO 48
(Metal)

ABSOLUTE RATINGS (limiting values)

Symbol	Parameter	Value	Unit
I _{T(RMS)}	RMS on-state Current (360° conduction angle) T _C = 60 °C	35	A
I _{TSM}	Non Repetitive Surge Peak on-state Current (T _J initial = 25 °C - Half sine wave)	t = 8.3 ms	330
		t = 10 ms	300
I ² t	I ² t Value for Fusing t = 10 ms	450	A ² s
di/dt	Critical Rate of Rise of on-state Current (1)	Repetitive F = 50 Hz	20
		Non Repetitive	100
T _{stg} T _J	Storage and Operating Junction Temperature Range	- 40 to 150	°C
		- 40 to 110	°C

Symbol	Parameter	TRAL				Unit
		1135D	2235D	3335D	3835D	
V _{DRM}	Repetitive Peak off-state Voltage (2)	200	400	600	700	V

(1) I_G = 1.5 A di/dt = 1 A/μs
(2) T_J = 110 °C.

THERMAL RESISTANCES

Symbol	Parameter	Value	Unit
R _{th (c-h)}	Contact (case-heat-sink) for Recommended Stud Torque	0.4	°C/W
R _{th (j-c) DC}	Junction to Case for DC	1.12	°C/W
R _{th (j-c) AC}	Junction to Case for 360 ° Conduction Angle (F = 50 Hz)	0.84	°C/W

GATE CHARACTERISTICS (maximum values)

$P_{GM} = 40 \text{ W}$ ($t_p = 10 \mu\text{s}$) $I_{GM} = 6 \text{ A}$ ($t_p = 10 \mu\text{s}$)
 $P_{G(AV)} = 1 \text{ W}$ $V_{GM} = 16 \text{ V}$ ($t_p = 10 \mu\text{s}$)

ELECTRICAL CHARACTERISTICS

Symbol	Test Conditions			Quadrants	Min.	Typ.	Max.	Unit
I_{GT}	$T_j = 25 \text{ }^\circ\text{C}$ Pulse Duration > 20 μs	$V_D = 12 \text{ V}$	$R_L = 33 \text{ } \Omega$	I-II-III			100	mA
				IV			150	
V_{GT}	$T_j = 25 \text{ }^\circ\text{C}$ Pulse Duration > 20 μs	$V_D = 12 \text{ V}$	$R_L = 33 \text{ } \Omega$	I-II-III-IV			1.5	V
V_{GD}	$T_j = 110 \text{ }^\circ\text{C}$	$V_D = V_{DRM}$	$R_L = 3.3 \text{ k}\Omega$	I-II-III-IV	0.2			V
I_H^*	$T_j = 25 \text{ }^\circ\text{C}$	$I_T = 500 \text{ mA}$	Gate Open				100	mA
I_L	$T_j = 25 \text{ }^\circ\text{C}$ Pulse Duration > 20 μs	$V_D = 12 \text{ V}$	$I_G = 300 \text{ mA}$	I-III-IV		60		mA
				II		120		
V_{TM}^*	$T_j = 25 \text{ }^\circ\text{C}$	$I_{TM} = 53 \text{ A}$	$t_p = 10 \text{ ms}$				2	V
I_{DRM}^*	$T_j = 110 \text{ }^\circ\text{C}$	V_{DRM} Specified					4	mA
dv/dt^*	$T_j = 110 \text{ }^\circ\text{C}$	Gate Open			250			V/ μs
	Linear Slope up to $V_D = 67\% V_{DRM}$							
$(dv/dt)_c^*$	$T_C = 60 \text{ }^\circ\text{C}$	$V_D = V_{DRM}$	$I_T = 53 \text{ A}$		10			V/ μs
	$(di/dt)_c = 15.5 \text{ A/ms}$							
t_{gt}	$T_j = 25 \text{ }^\circ\text{C}$ $I_G = 200 \text{ mA}$	$V_D = V_{DRM}$ $di_G/dt = 2 \text{ A}/\mu\text{s}$	$I_T = 53 \text{ A}$	I-II-III-IV		3		μs

* For either polarity of electrode A_2 voltage with reference to electrode A_1 .

PACKAGE MECHANICAL DATA

TO 48 Metal

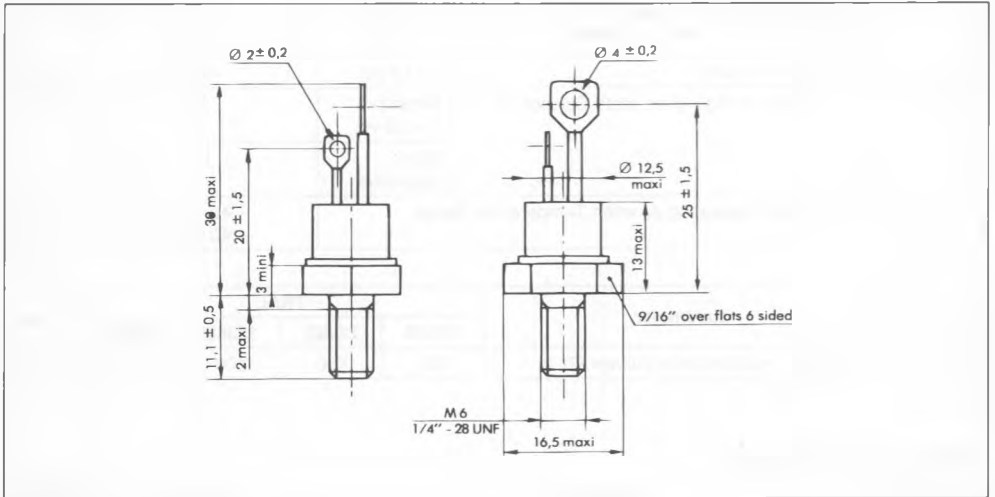

Cooling method : by conduction (method C)
 Marking : type number
 Weight : $13.5 \pm 1 \text{ g}$
 Polarity : anode to case
 Stud torque : 3.5 mAN min - 3.8 mAN max.

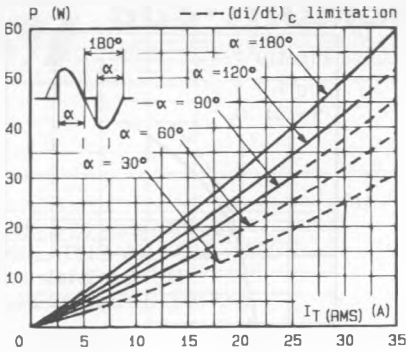

Fig.1 - Maximum mean power dissipation versus RMS on-state current (F = 60 Hz).

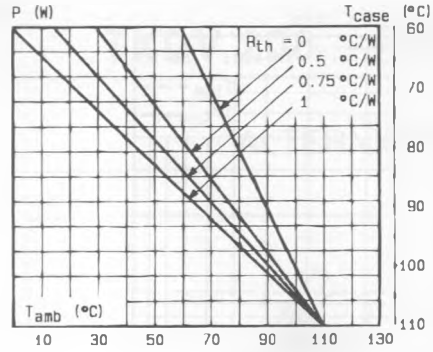

Fig.2 - Correlation between maximum mean power dissipation and maximum allowable temperatures (T_{amb} and T_{case}) for different thermal resistances heatsink + contact.

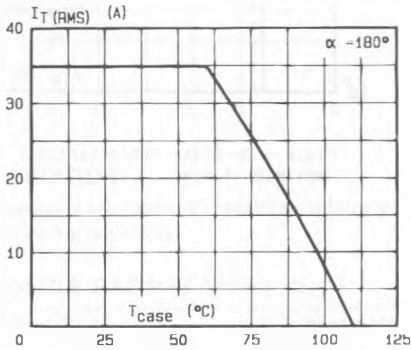

Fig.3 - RMS on-state current versus case temperature.

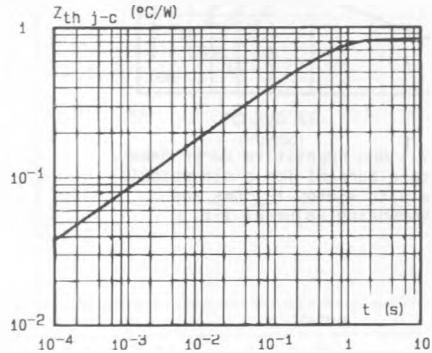

Fig.4 - Thermal transient impedance junction to case versus pulse duration.

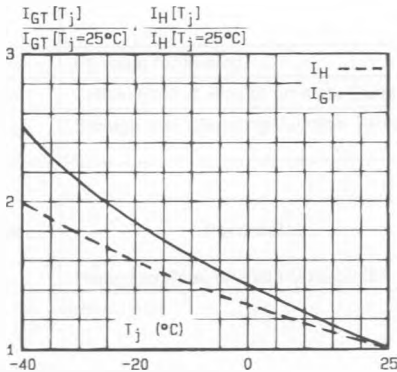

Fig.5 - Relative variation of gate trigger current and holding current versus junction temperature.

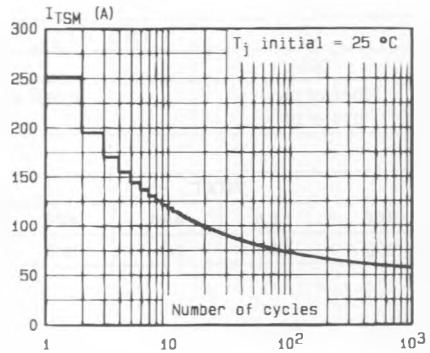

Fig.6 - Non repetitive surge peak on-state current versus number of cycles.

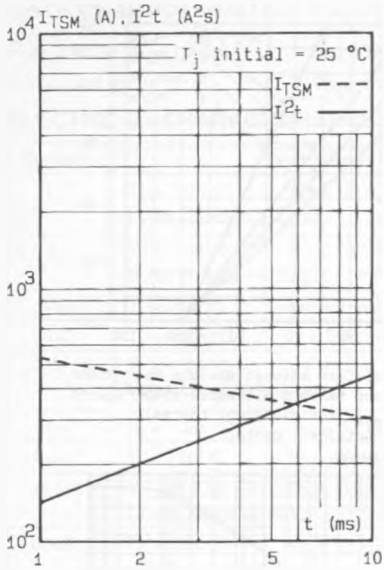

Fig.7 - Non repetitive surge peak on-state current for a sinusoidal pulse with width: $t \leq 10\text{ms}$, and corresponding value of I^2t .

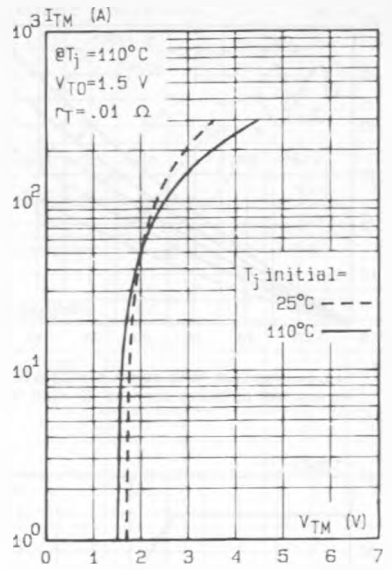

Fig.8 - On-state characteristic (maximum values).