

DATA SHEET

PDIUSBP11

Universal Serial Bus transceiver

Product specification

1997 Sep 16

Universal Serial Bus transceiver

PDIUSBP11

FEATURES

- Utilizes digital inputs and outputs to transmit and receive USB cable data
- Supports 12Mbit/s "Full Speed" and 1.5Mbit/s "Low Speed" serial data transmission
- Compatible with the VHDL "Serial Interface Engine" from USB developer's conference
- Available in SO, 14 pin package
- Hysteresis on D+, D-, V_{MO} inputs

DESCRIPTION

The PDIUSBP11 is a one chip generic USB transceiver. It is designed to allow 5.0V or 3.3V programmable and standard logic to interface with the physical layer of the Universal Serial Bus. It is capable of transmitting and receiving serial data at both full speed (12Mbit/s) and low speed (1.5Mbit/s) data rates. The outputs from the serial interface engine (inputs VPO and VMO on the PDIUSBP11) are driven by the host. The gated inputs (outputs VP and VM on the PDIUSBP11) are to be decoded by the host.

Implementation of the Serial Interface Engine along with the USB transceiver allow the designer to make flexible USB compatible devices with widely available logic components.

ORDERING INFORMATION

PACKAGES	TEMPERATURE RANGE	OUTSIDE NORTH AMERICA	NORTH AMERICA	PKG. DWG. #
14-pin plastic SO	0°C to +70°C	PDIUSBP11 D	PDIUSBP11 D	SOT108-1
14-pin plastic SSOP	0°C to +70°C	PDIUSBP11 DB	PDIUSBP11 DB	SOT337-1
14-pin plastic TSSOP	0°C to +70°C	PDIUSBP11 PW	PDUSBP11 PW DH	SOT402-1

PIN CONFIGURATION

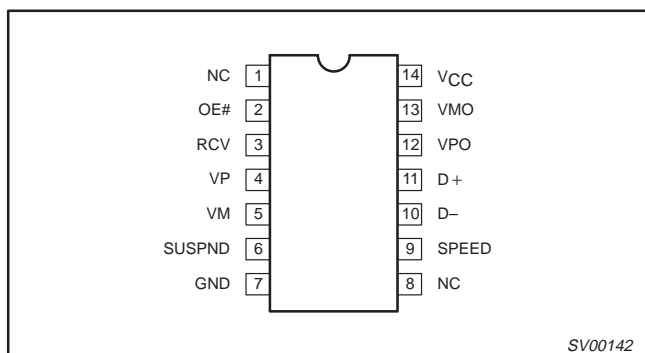

FUNCTIONAL DIAGRAM

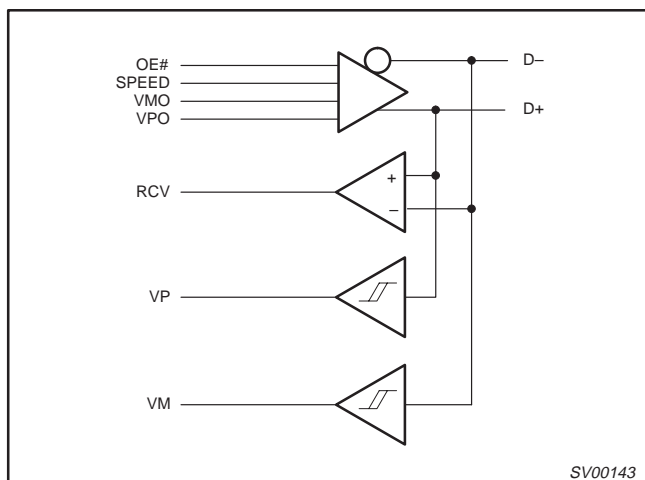

PIN DESCRIPTION

PIN No.	PIN SYMBOL	I/O	NAME AND FUNCTION															
3	RCV	O	Receive data. CMOS level output for USB differential input															
2	OE#	I	Output Enable. Active LOW, enables the transceiver to transmit data on the bus. When not active the transceiver is in receive mode															
12, 13	VPO, VMO	I	Inputs to differential driver. (Outputs from SIE). <table border="1" style="margin-left: 20px;"> <thead> <tr> <th>VPO</th> <th>VMO</th> <th>RESULT</th> </tr> </thead> <tbody> <tr> <td>0</td> <td>0</td> <td>SE0</td> </tr> <tr> <td>0</td> <td>1</td> <td>Logic "0"</td> </tr> <tr> <td>1</td> <td>0</td> <td>Logic "1"</td> </tr> <tr> <td>1</td> <td>1</td> <td>Undefined</td> </tr> </tbody> </table>	VPO	VMO	RESULT	0	0	SE0	0	1	Logic "0"	1	0	Logic "1"	1	1	Undefined
VPO	VMO	RESULT																
0	0	SE0																
0	1	Logic "0"																
1	0	Logic "1"																
1	1	Undefined																
4, 5	VP, VM	O	Gated version of D- and D+. Outputs are logic "0" and logic "1". Used to detect single ended zero (SE0#), error conditions, and interconnect speed. (Inputs to SIE). <table border="1" style="margin-left: 20px;"> <thead> <tr> <th>VP</th> <th>VM</th> <th>RESULT</th> </tr> </thead> <tbody> <tr> <td>0</td> <td>0</td> <td>SE0</td> </tr> <tr> <td>0</td> <td>1</td> <td>Low Speed</td> </tr> <tr> <td>1</td> <td>0</td> <td>Full Speed</td> </tr> <tr> <td>1</td> <td>1</td> <td>Error</td> </tr> </tbody> </table>	VP	VM	RESULT	0	0	SE0	0	1	Low Speed	1	0	Full Speed	1	1	Error
VP	VM	RESULT																
0	0	SE0																
0	1	Low Speed																
1	0	Full Speed																
1	1	Error																
11, 10	D+, D-	I/O	Data+, Data-. Differential data bus conforming to the Universal Serial Bus standard.															
6	SUSPND	I	Suspend. Enables a low power state while the USB bus is inactive. While the suspnd pin is active it will drive the RCV pin to a logic "0" state.															
9	SPEED	I	Edge rate control. Logic "1" operates at edge rates for "full speed". Logic "0" operates edge rates for "low speed".															
14	V _{CC}		3.0V to 3.6V power supply															
7	GND		Ground reference															

Universal Serial Bus transceiver

PDIUSBP11

RECOMMENDED OPERATING CONDITIONS

SYMBOL	PARAMETER	CONDITIONS	LIMITS		UNIT
			MIN.	MAX.	
V_{CC}	DC supply voltage		3.0	3.6	V
V_I	DC Input voltage range		0	5.5	V
$V_{I/O}$	DC input range for I/O's		0	V_{CC}	V
V_O	DC output voltage range		0	V_{CC}	V
T_{amb}	Operating ambient temperature range in free air	See DC and AC characteristics for individual device	0	+70	°C

ABSOLUTE MAXIMUM RATINGS^{1, 2}

In accordance with the Absolute Maximum Rating System (IEC 134) Voltages are referenced to GND (ground = 0V)

SYMBOL	PARAMETER	CONDITIONS	LIMITS		UNIT
			MIN	MAX	
V_{CC}	DC supply voltage		-0.5	+6.5	V
I_{IK}	DC input diode current	$V_I < 0$	-	-50	mA
V_I	DC input voltage	Note 3	-0.5	+5.5	V
$V_{I/O}$	DC input voltage range for I/O's		-0.5	$V_{CC} + 0.5$	V
I_{OK}	DC output diode current	$V_O > V_{CC}$ or $V_O < 0$	-	±50	mA
V_O	DC output voltage	Note 3	-0.5	$V_{CC} + 0.5$	V
I_O	DC output source or sink current for VP/VM, RCV pins	$V_O = 0$ to V_{CC}	-	±15	mA
I_O	DC output source or sink current for D+/D- pins	$V_O = 0$ to V_{CC}	-	±50	mA
I_{GND}, I_{CC}	DC V_{CC} or GND current		-	±100	mA
T_{stg}	Storage temperature range		-60	+150	°C
P_{tot}	Power dissipation per package				mW

NOTES:

- Stresses beyond those listed may cause permanent damage to the device. These are stress ratings only and functional operation of the device at these or any other conditions beyond those indicated under "recommended operating conditions" is not implied. Exposure to absolute-maximum-rated conditions for extended periods may affect device reliability.
- The performance capability of a high-performance integrated circuit in conjunction with its thermal environment can create junction temperatures which are detrimental to reliability. The maximum junction temperature of this integrated circuit should not exceed 150°C.
- The input and output voltage ratings may be exceeded if the input and output clamp current ratings are observed.

Universal Serial Bus transceiver

PDIUSBP11

DC ELECTRICAL CHARACTERISTICS

Over recommended operating conditions

Voltages are referenced to GND (ground = 0V)

SYMBOL	PARAMETER	TEST CONDITIONS	LIMITS			UNIT
			Temp = 0°C to +70°C			
			MIN	TYP ¹	MAX	
V _{IH}	HIGH level input	V _{CC} = 3.0V to 3.6V ³	2.0			V
V _{IL}	LOW level input	V _{CC} = 3.0V to 3.6V ³			0.8	V
R _D H	Output impedance (HIGH state)	Note 2	28	34	43	Ω
R _D L	Output impedance (LOW state)	Note 2	28	35	51	Ω
V _{OH}	HIGH level output ³	V _{CC} = 3.0V; I _O = 6mA	2.2	2.7		V
		V _{CC} = 3.0V; I _O = 4mA	2.4			
		V _{CC} = 3.0V; I _O = 100μA	2.8	–		
V _{OL}	LOW level output ³	V _{CC} = 3.0V; I _O = 6mA		0.3	0.8	V
		V _{CC} = 3.0V; I _O = 4mA			0.5	
		V _{CC} = 3.0V; I _O = 100μA		–	0.2	
I _{CCQ}	Quiescent supply current	V _{CC} = 3.6V; V _I = V _{CC} or GND; I _O = 0		330	600	μA
I _{CCS}	Supply current in Suspend	V _{CC} = 3.6V; V _I = V _{CC} or GND; I _O = 0		–	65	μA
I _{CCFS}	Active supply current (Full Speed)	V _{CC} = 3.3V		10	30	mA
I _{CCLS}	Active supply current (Low Speed)	V _{CC} = 3.3V		2	25	mA
I _I	Input leakage current	V _{CC} = 3.6V; V _I = 5.5V or GND; not for I/O pins		±0.1	±5	μA
I _{OZ}	3-State output OFF-state current	V _I = V _{IH} or V _{IL} ; V _O = V _{CC} or GND ²			±10	μA

NOTES:

1. All typical values are at V_{CC} = 3.3V and T_{amb} = 25°C.
2. This value includes an external resistor of 24Ω ± 1%. See "Load D+ and D–" diagram for testing details.
3. All signals except D+ and D–.

AC CHARACTERISTICSGND = 0V, t_R = t_F = 3.0ns, C_L = 50pF, R_L = 500Ω, V_{CC} = 3.3V

SYMBOL	PARAMETER	TEST CONDITIONS	WAVEFORMS	LIMITS					UNIT
				T _{amb} = 25°C			T _{amb} = 0°C to +70°C		
				MIN	TYP	MAX	MIN	MAX	
t _{PLH}	VMO/VPO to D+/D– Full Speed		1	0		12	0	15	ns
t _{PHL}				0		12	0	15	
t _{rise}	Rise and Fall Times Full Speed		2	4		20	4	20	ns
t _{fall}				4		20	4	20	
t _{PLH}	VMO/VPO to D+/D– Low Speed		1	30		300	30	300	ns
t _{PHL}				30		300	30	300	
t _{rise}	Rise and Fall Times Low Speed		2	75		300	75	300	ns
t _{fall}				75		200	75	200	
t _{PLH}	D+/D– to RCV		3			16		16	ns
t _{PHL}						16		20	
t _{PLH}	D+/D– to VP/VM		1			8		8	ns
t _{PHL}						8		12	
t _{PHZ}	OE# to D+/D– RL = 500Ω		4			12		12	ns
t _{PZH}						12		15	
t _{PLZ}						10		10	
t _{PZL}						10		15	
t _{su}	Setup for SPEED		5	0					ns
V _{cr}	Crossover point	Note 1	3	1.3	2.0	1.3	2.0		V

NOTE:

1. The crossover point is in the range of 1.3V to 2.5V for the low speed mode with a 50pF capacitance. In the low-speed mode with a 100pF or greater capacitance, the crossover point is in the range of 1.3V to 2.0V.

Universal Serial Bus transceiver

PDIUSBP11

AC WAVEFORMS

$V_M = 1.5V$

$V_X = V_{OL} + 0.3V$

$V_Y = V_{OH} - 0.3V$

V_{OL} and V_{OH} are the typical output voltage drops that occur with the output load. (V_{CC} never goes below 3.0V).

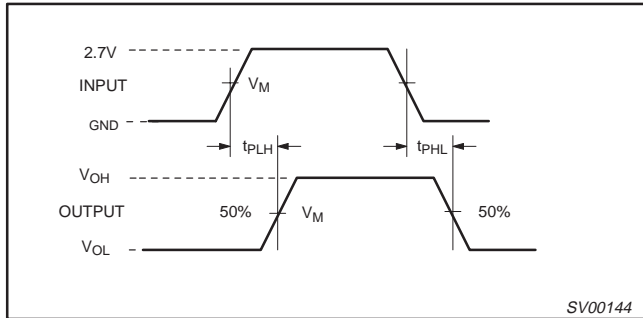

Waveform 1. D+/D- to VP/VM or VPO/VMO to D+/D-

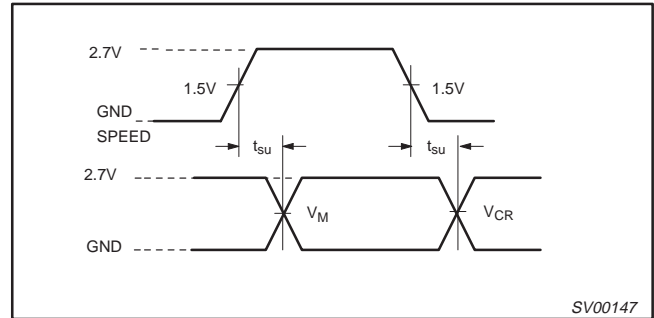

Waveform 5. Setup for Speed

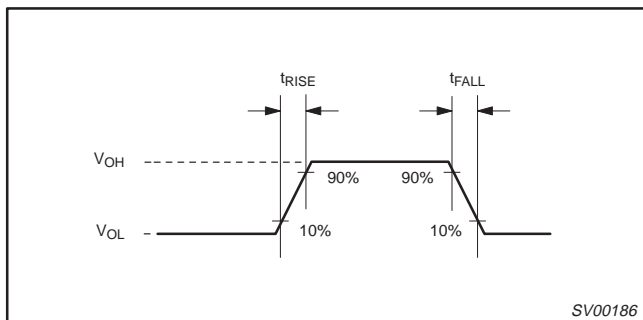

Waveform 2. Rise and Fall Times

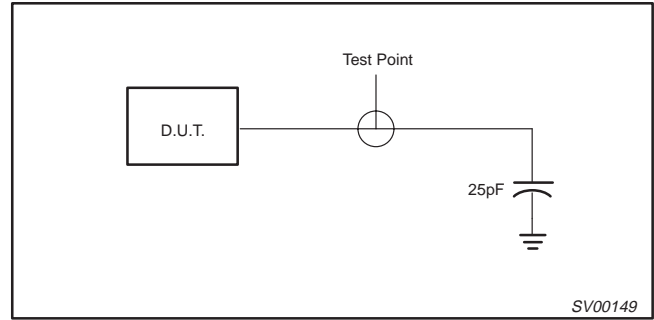

Load for VM/VP and RCV

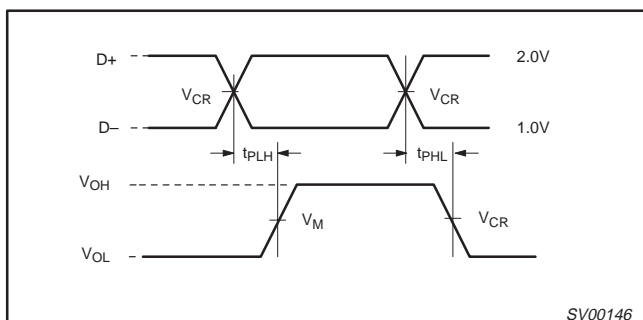

Waveform 3. D+/D- to RCV

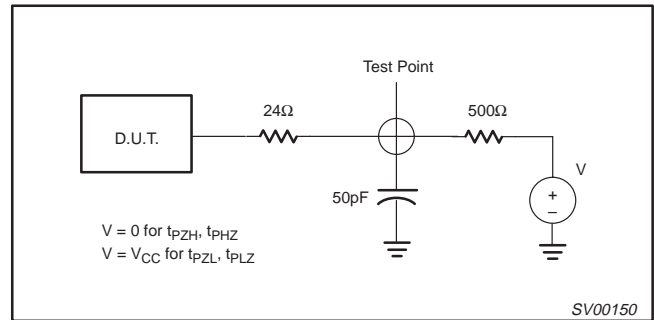

Load for Enable and Disable Times

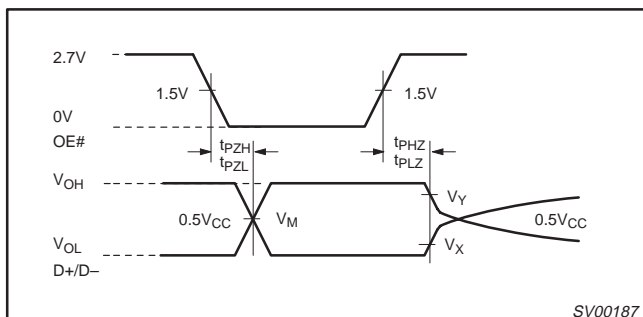

Waveform 4. OE# to D+/D-

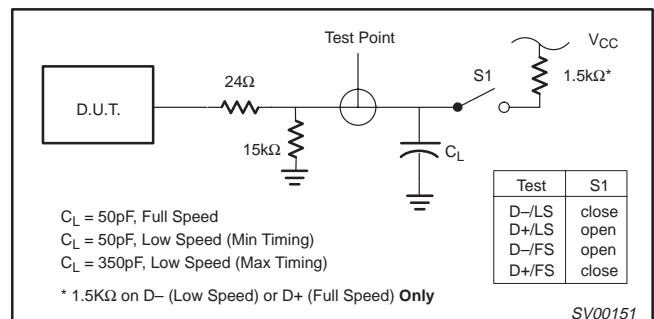

Load for D+/D-

Universal Serial Bus transceiver

PDIUSBP11

SO14: plastic small outline package; 14 leads; body width 3.9 mm

SOT108-1

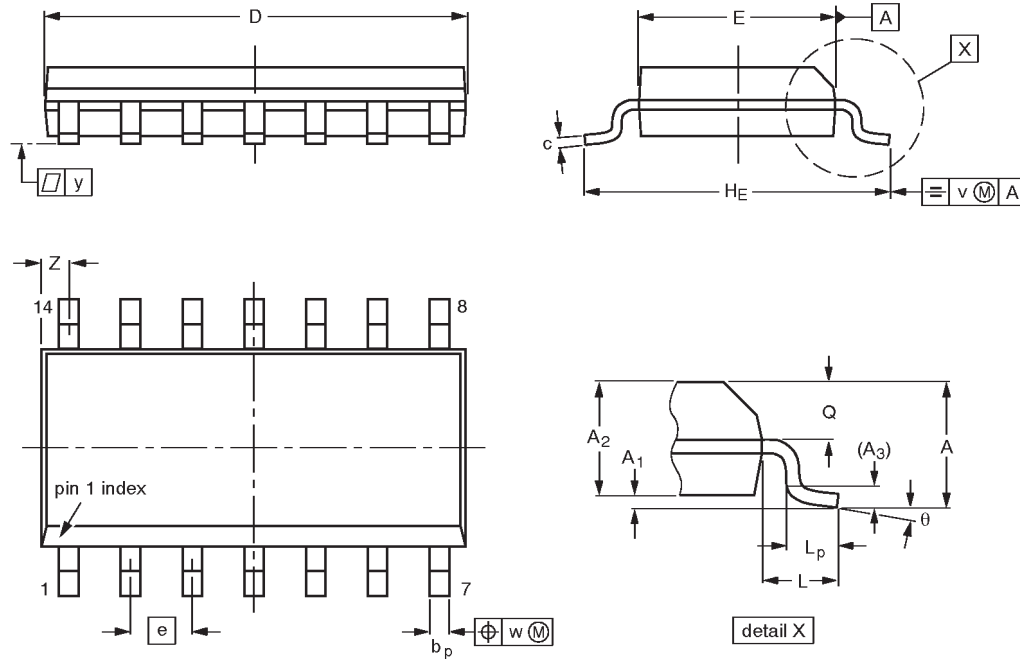

DIMENSIONS (inch dimensions are derived from the original mm dimensions)

UNIT	A max.	A ₁	A ₂	A ₃	b _p	c	D ⁽¹⁾	E ⁽¹⁾	e	H _E	L	L _p	Q	v	w	y	Z ⁽¹⁾	θ
mm	1.75	0.25 0.10	1.45 1.25	0.25	0.49 0.36	0.25 0.19	8.75 8.55	4.0 3.8	1.27	6.2 5.8	1.05	1.0 0.4	0.7 0.6	0.25	0.25	0.1	0.7 0.3	8° 0°
inches	0.069	0.0098 0.0039	0.057 0.049	0.01	0.019 0.014	0.0098 0.0075	0.35 0.34	0.16 0.15	0.050	0.24 0.23	0.041	0.039 0.016	0.028 0.024	0.01	0.01	0.004	0.028 0.012	

Note

1. Plastic or metal protrusions of 0.15 mm maximum per side are not included.

OUTLINE VERSION	REFERENCES				EUROPEAN PROJECTION	ISSUE DATE
	IEC	JEDEC	EIAJ			
SOT108-1	076E06S	MS-012AB				91-08-13 95-01-23

Universal Serial Bus transceiver

PDIUSBP11

SSOP14: plastic shrink small outline package; 14 leads; body width 5.3 mm

SOT337-1



DIMENSIONS (mm are the original dimensions)

UNIT	A max.	A ₁	A ₂	A ₃	b _p	c	D ⁽¹⁾	E ⁽¹⁾	e	H _E	L	L _p	Q	v	w	y	Z ⁽¹⁾	θ
mm	2.0	0.21 0.05	1.80 1.65	0.25	0.38 0.25	0.20 0.09	6.4 6.0	5.4 5.2	0.65	7.9 7.6	1.25	1.03 0.63	0.9 0.7	0.2	0.13	0.1	1.4 0.9	8° 0°

Note

1. Plastic or metal protrusions of 0.25 mm maximum per side are not included.

OUTLINE VERSION	REFERENCES				EUROPEAN PROJECTION	ISSUE DATE
	IEC	JEDEC	EIAJ			
SOT337-1		MO-150AB				95-02-04 96-01-18

Universal Serial Bus transceiver

PDIUSBP11

TSSOP14: plastic thin shrink small outline package; 14 leads; body width 4.4 mm

SOT402-1

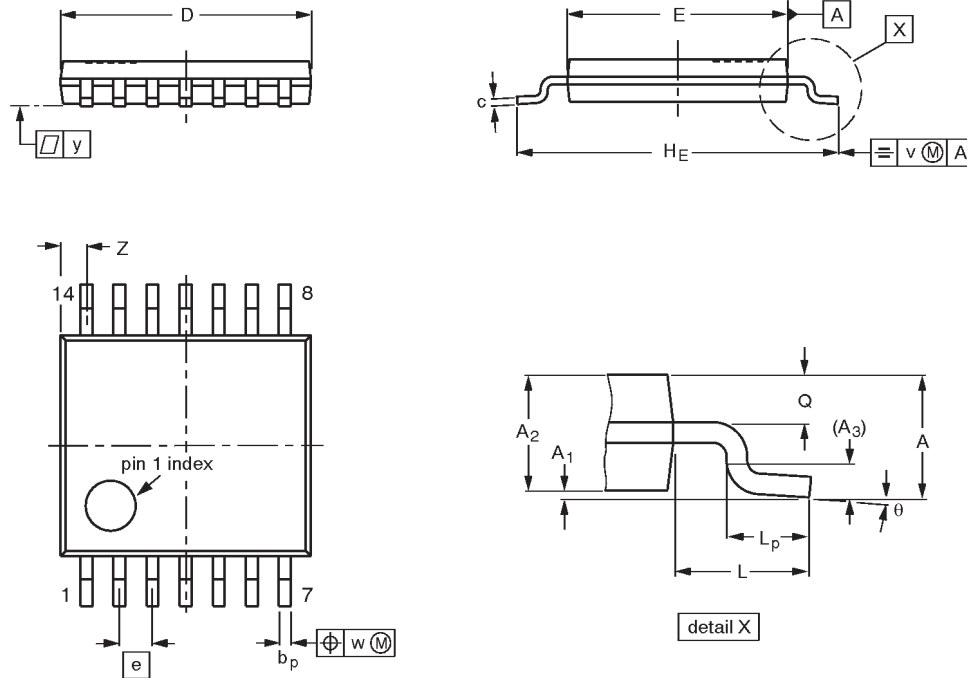

DIMENSIONS (mm are the original dimensions)

UNIT	A max.	A ₁	A ₂	A ₃	b _p	c	D ⁽¹⁾	E ⁽²⁾	e	H _E	L	L _p	Q	v	w	y	Z ⁽¹⁾	θ
mm	1.10	0.15 0.05	0.95 0.80	0.25	0.30 0.19	0.2 0.1	5.1 4.9	4.5 4.3	0.65	6.6 6.2	1.0	0.75 0.50	0.4 0.3	0.2	0.13	0.1	0.72 0.38	8° 0°

Notes

1. Plastic or metal protrusions of 0.15 mm maximum per side are not included.
2. Plastic interlead protrusions of 0.25 mm maximum per side are not included.

OUTLINE VERSION	REFERENCES				EUROPEAN PROJECTION	ISSUE DATE
	IEC	JEDEC	EIAJ			
SOT402-1		MO-153				-94-07-12- 95-04-04

Universal Serial Bus transceiver

PDIUSBP11

NOTES

Universal Serial Bus transceiver

PDIUSBP11

DEFINITIONS

Data Sheet Identification	Product Status	Definition
<i>Objective Specification</i>	Formative or in Design	This data sheet contains the design target or goal specifications for product development. Specifications may change in any manner without notice.
<i>Preliminary Specification</i>	Preproduction Product	This data sheet contains preliminary data, and supplementary data will be published at a later date. Philips Semiconductors reserves the right to make changes at any time without notice in order to improve design and supply the best possible product.
<i>Product Specification</i>	Full Production	This data sheet contains Final Specifications. Philips Semiconductors reserves the right to make changes at any time without notice, in order to improve design and supply the best possible product.

Philips Semiconductors and Philips Electronics North America Corporation reserve the right to make changes, without notice, in the products, including circuits, standard cells, and/or software, described or contained herein in order to improve design and/or performance. Philips Semiconductors assumes no responsibility or liability for the use of any of these products, conveys no license or title under any patent, copyright, or mask work right to these products, and makes no representations or warranties that these products are free from patent, copyright, or mask work right infringement, unless otherwise specified. Applications that are described herein for any of these products are for illustrative purposes only. Philips Semiconductors makes no representation or warranty that such applications will be suitable for the specified use without further testing or modification.

LIFE SUPPORT APPLICATIONS

Philips Semiconductors and Philips Electronics North America Corporation Products are not designed for use in life support appliances, devices, or systems where malfunction of a Philips Semiconductors and Philips Electronics North America Corporation Product can reasonably be expected to result in a personal injury. Philips Semiconductors and Philips Electronics North America Corporation customers using or selling Philips Semiconductors and Philips Electronics North America Corporation Products for use in such applications do so at their own risk and agree to fully indemnify Philips Semiconductors and Philips Electronics North America Corporation for any damages resulting from such improper use or sale.

Philips Semiconductors
811 East Arques Avenue
P.O. Box 3409
Sunnyvale, California 94088-3409
Telephone 800-234-7381

Philips Semiconductors and Philips Electronics North America Corporation register eligible circuits under the Semiconductor Chip Protection Act.
 © Copyright Philips Electronics North America Corporation 1997
 All rights reserved. Printed in U.S.A.