

# PBL 3767, PBL 3767/6 Subscriber Line Interface Circuit

## Description

The PBL 3767 Subscriber Line Interface Circuit (SLIC) is a monolithic integrated circuit, manufactured in 75 V bipolar technology. The PBL 3767 SLIC facilitates the design of cost effective, high performance on-premises (ONS) analog line interface cards for PABX systems and terminal adapters. Small package size and few required external components result in a miniaturized design.

The PBL 3767 programmable, resistive battery feed system with short loop current limiting can operate with battery supply voltages between -24 V and -58 V.

The SLIC incorporates loop current and ring trip detection functions as well as a ring relay driver.

The two- to four-wire and four- to two-wire voice frequency (vf) signal conversion, i.e. the hybrid function, is provided by the SLIC in conjunction with either a conventional or a programmable CODEC/filter.

The PBL 3767 package is a 22 pin, plastic dual-in-line (batwing) or a 28-pin, plastic j-leaded chip carrier (PLCC).

The differences between PBL 3767 and PBL 3767/6 are the specifications for balance, output offset voltage, and insertions loss.

## Key Features

- Low cost
- Few external components
- Programmable, resistive battery feed with short loop current limiting
- Line feed characteristics independent of battery supply variations
- -24 V to -58 V battery supply voltage range
- Detectors
  - programmable loop current detector
  - ring trip detector
- Ring relay driver
- Hybrid function with conventional or programmable CODEC/filters
- Line terminating impedance, complex or real, set by a simple external network or controlled by a programmable CODEC/filter
- Low on-hook power dissipation: 20 mW @ -28 V (35 mW @ -48 V)
- Tip-ring open circuit state for subscriber loop power denial
- Idle noise typ. -83 dBmp, typ. 7 dBmC
- On-hook transmission

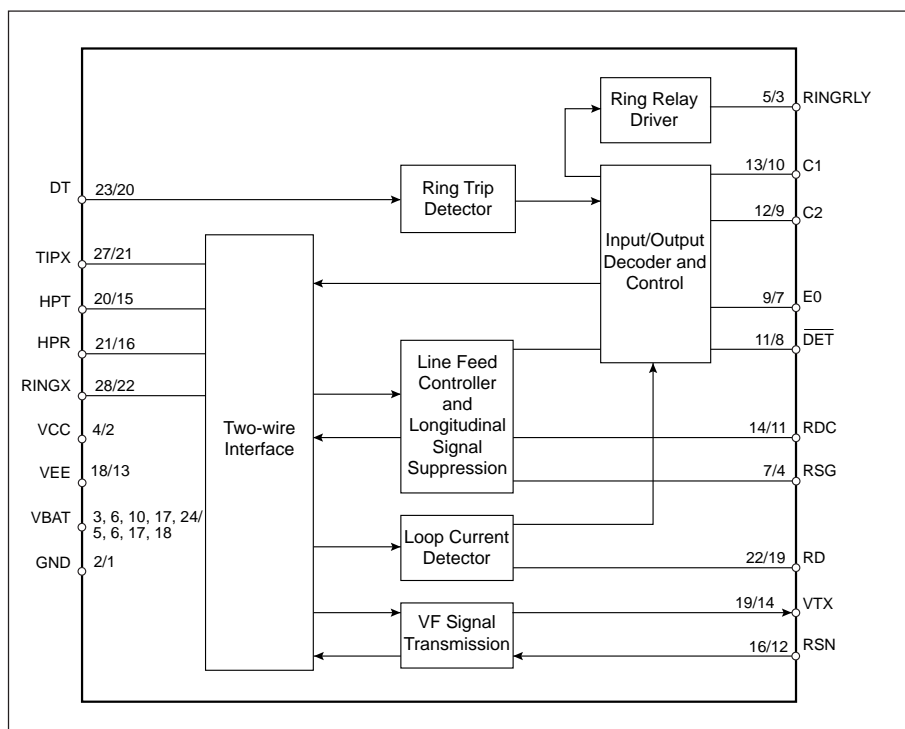
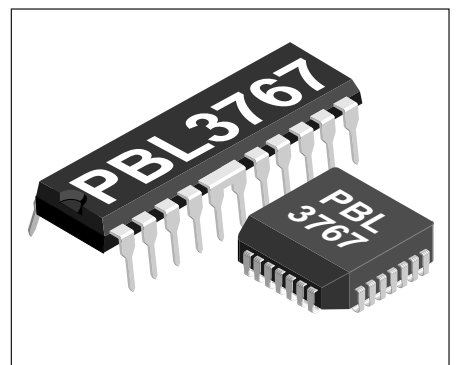

Figure 1. Block diagram. Pin numbers PLCC/DIP.

## Absolute Maximum Ratings

| Parameter  | Symbol               | Min            | Max            | Unit |
|--|----------------------|----------------|----------------|------|
| <b>Temperature and humidity</b>  |                      |                |                |      |
| Storage temperature range  | $T_{Stg}$            | -60            | +150           | °C   |
| Operating temperature range  | $T_{Case}$           | -10            | +110           | °C   |
| Operating junction temperature   | $T_J$                | -10            | +140           | °C   |
| Storage humidity   | $R_H$                | 5              | 95             | % RH |
| <b>Power supply, <math>-10\text{ °C} &lt; T_{Amb} &lt; 80\text{ °C}</math></b>                       |                      |                |                |      |
| $V_{CC}$ with respect to GND   | $V_{CC}$             | -0.5           | 6.5            | V    |
| $V_{EE}$ with respect to GND   | $V_{EE}$             | -6.5           | 0.5            | V    |
| $V_{Bat}$ with respect to GND  | $V_{Bat}$            | -70            | $V_{EE} + 0,7$ | V    |
| <b>Power dissipation</b>   |                      |                |                |      |
| Continuous power dissipation at $T_{Amb} \leq 70\text{ °C}$  | $P_D$                |                | 1.5            | W    |
| Peak power dissipation at $T_{Amb} = 70\text{ °C}$ , $t < 10\text{ ms}$ , $t_{Rep} > 10\text{ sec.}$ | $P_{DP}$             |                | 4              | W    |
| <b>Relay driver</b>  |                      |                |                |      |
| Ring relay supply voltage  | $V_{RRly}$           | $V_{Bat}$      | 0              | V    |
| Ring relay current   | $I_{RRly}$           |                | 50             | mA   |
| <b>Ring trip comparator</b>  |                      |                |                |      |
| Input voltage  | $V_{DT}$             | $V_{Bat}$      | 0              | V    |
| Input current  | $I_{DT}$             | -2             | 2              | mA   |
| <b>Digital inputs, outputs (C1, C2, E0, <math>\overline{DET}</math>)</b>                             |                      |                |                |      |
| Input voltage  | $V_{ID}$             | 0              | $V_{CC}$       | V    |
| Output voltage ( $\overline{DET}$ disabled)  | $V_{OD}$             | 0              | $V_{CC}$       | V    |
| Output current ( $\overline{DET}$ enabled)   | $I_{OD}$             |                | 5              | mA   |
| <b>TIPX and RINGX terminals, <math>V_{Bat} = -50V</math></b>   |                      |                |                |      |
| TIPX or RINGX voltage, continuous (Note 1)   | $V_{T1} V_R$         | $V_{Bat}$      | 0.5            | V    |
| TIPX or RINGX, pulse = $t_w < 10\text{ ms}$ , $t_{Rep} > 10\text{ s}$ (Notes 2, 3)                   | $V_{T1} V_R$         | $V_{Bat} - 20$ | 5              | V    |
| TIPX or RINGX, pulse = $t_w < 1\text{ }\mu\text{s}$ , $t_{Rep} > 10\text{ s}$ (Notes 2, 3)           | $V_{T1} V_R$         | $V_{Bat} - 40$ | 10             | V    |
| TIP or RING, pulse = $t_w < 250\text{ ns}$ , $t_{Rep} > 10\text{ s}$ (Notes 2, 3)                    | $V_{T1} V_R$         | $V_{Bat} - 70$ | 15             | V    |
| TIPX or RINGX Current  |                      |                |                |      |
| Active   | $I_{Ldc} + I_{Lodc}$ |                | 80             | mA   |
| Stand-by   | $I_{Ldc}$            |                | 25             | mA   |

## Recommended Operating Conditions

| Parameter                                 | Symbol     | Min   | Max   | Unit |
|---|------------|-------|-------|------|
| Case temperature                          | $T_{Case}$ | 0     | 90    | °C   |
| $V_{CC}$ with respect to ground           | $V_{CC}$   | 4.75  | 5.25  | V    |
| $V_{EE}$ with respect to ground           | $V_{EE}$   | -5.25 | -4.75 | V    |
| $V_{Bat}$ with respect to ground (Note 4) | $V_{Bat}$  | -58   | -24   | V    |

## Notes

- With a diode ( $D_2$ ) connected in series with the  $V_{Bat}$  supply, as shown in figure 11, -70 V may be continuously applied to the TIPX or RINGX lead.
- These voltage ratings require a diode ( $D_2$ ) to be installed in series with the  $V_{Bat}$  supply as shown in figure 11.
- $V_T$  and  $V_R$  are referenced to ground.  $t_w$  is the pulse width of a rectangular test pulse and  $t_{rep}$  is the pulse repetition rate.
- $-24\text{ V} < V_{Bat} < -21\text{ V}$  may be used in applications requiring maximum signal amplitudes less than  $3\text{ V}_{pk}$  (8.75 dBm, 600 ohms).

**Electrical Characteristics**

0 °C < T<sub>Amb</sub> < 70 °C, V<sub>CC</sub> = +5 V ±5 %, V<sub>EE</sub> = -5 V ±5 %, V<sub>Bat</sub> = -48 V, R<sub>SG</sub> = 0 ohm, R<sub>DC</sub> = 20 kohms, R<sub>D</sub> = ∞, Z<sub>L</sub> = 600 ohms, C<sub>HP</sub> = 33 nF, C<sub>DC</sub> = 3.3 μF unless otherwise specified.

| Parameter   | Ref Fig. | Conditions  | Min | Typ | Max | Unit                   |
|---|----------|---|-----|-----|-----|------------------------|
| <b>Two-wire port</b>  |          |   |     |     |     |                        |
| Overload level, V <sub>TRO</sub>                                | 2        | Z <sub>L</sub> = 600 ohms, 1% THD, Note 1   | 3.1 |     |     | V <sub>Pk</sub>        |
| Input impedance, Z <sub>TRX</sub>                               |          | Note 2  |     |     |     |                        |
| Longitudinal impedance, Z <sub>LoT</sub> , Z <sub>LoR</sub>     |          | f < 100 Hz  |     | 25  | 40  | ohm/wire               |
| Longitudinal current limit, I <sub>LoT</sub> , I <sub>LoR</sub> |          | active state, C2, C1 = 1, 0   |     | 20  |     | mA <sub>pk</sub> /wire |
| Longitudinal to metallic balance, B <sub>LM</sub>               |          | IEEE standard 455-1985<br>0.2 kHz ≤ f ≤ 3 kHz   |     |     |     |                        |
| PBL 3767  |          |   | 53  | 58  |     | dB                     |
| PBL 3767/6  |          |   | 48  | 58  |     | dB                     |
| Longitudinal to metallic balance, B <sub>LME</sub>              | 3        | $B_{LME} = 20 \cdot \log \frac{ E_{Lo} }{ V_{TR} }$<br>0.05kHz ≤ f ≤ 3.4kHz                                 |     |     |     |                        |
| PBL 3767  |          |   | 53  | 58  |     | dB                     |
| PBL 3767/6  |          |   | 48  | 58  |     | dB                     |
| Longitudinal to four-wire balance, B <sub>LFE</sub>             | 3        | $B_{LFE} = 20 \cdot \log \frac{ E_{Lo} }{ V_{TX} }$<br>0.05kHz ≤ f ≤ 3.4kHz                                 |     |     |     |                        |
| PBL 3767  |          |   | 53  | 58  |     | dB                     |
| PBL 3767/6  |          |   | 48  | 58  |     | dB                     |
| Metallic to longitudinal balance, B <sub>MLE</sub>              | 4        | $B_{MLE} = 20 \cdot \log \frac{ E_{TR} }{ V_{Lo} }$ , E <sub>RX</sub> = 0<br>0.2kHz ≤ f ≤ 3.4kHz            |     |     |     |                        |
| PBL 3767  |          |   | 50  | 55  |     | dB                     |
| PBL 3767/6  |          |   | 48  | 55  |     | dB                     |
| Four-wire to longitudinal balance, B <sub>FLE</sub>             | 4        | $B_{FLE} = 20 \cdot \log \frac{ E_{RX} }{ V_{Lo} }$ , E <sub>TR</sub> source removed<br>0.2kHz ≤ f ≤ 3.4kHz |     |     |     |                        |
|   |          |   | 40  | 55  |     | dB                     |

Figure 2. Overload level, V<sub>TRO</sub>, two-wire port.

$\frac{1}{\omega C} \ll R_L$ , R<sub>L</sub> = 600 ohms,  
R<sub>T</sub> = 600 kohms, R<sub>RX</sub> = 300 kohms

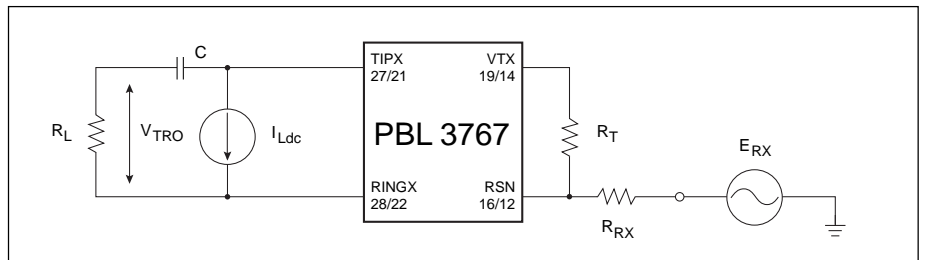
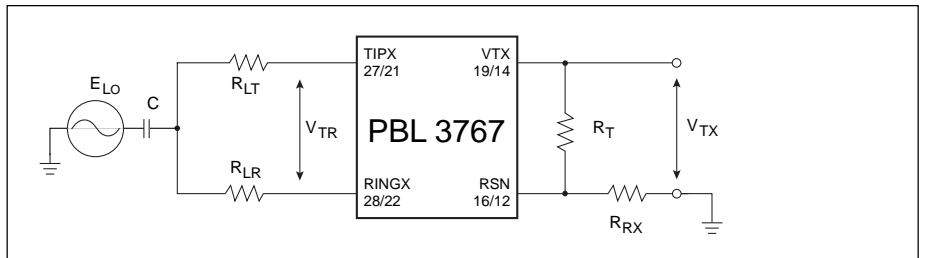

Figure 3. Longitudinal to metallic (B<sub>LME</sub>) and longitudinal to four-wire (B<sub>LFE</sub>) balance.

$\frac{1}{\omega C} \ll 150$  ohms, R<sub>LR</sub> = R<sub>LT</sub> = 300 ohms,  
R<sub>T</sub> = 600 kohms, R<sub>RX</sub> = 300 kohms



| Parameter   | Ref Fig. | Conditions   | Min   | Typ  | Max   | Unit     |
|---|----------|--|-------|------|-------|----------|
| Two-wire return loss, r   |          | $r = 20 \cdot \log \frac{ Z_{TRX} + Z_L }{ Z_{TRX} - Z_L }$ $Z_{TRX} \approx Z_L = \text{nom. } 600\Omega, \text{ Note 3}$ $0.2 \text{ kHz} \leq f \leq 0.5 \text{ kHz}$ $0.5 \text{ kHz} \leq f \leq 1.0 \text{ kHz}$ $1.0 \text{ kHz} \leq f \leq 3.4 \text{ kHz}$ | 25    | 30   |       | dB       |
| TIPX idle voltage, $V_{Ti}$   |          | active, $I_L = 0$  |       | -5   |       | V        |
|   |          | stand-by, $I_L = 0$  |       | 0    |       | V        |
| RINGX idle voltage, $V_{Ri}$  |          | active, $I_L = 0$  |       | -43  |       | V        |
|   |          | stand-by, $I_L = 0$  |       | -48  |       | V        |
| <b>Four-wire transmit port (VTX)</b>  |          |  |       |      |       |          |
| Overload level, $V_{TXO}$   | 5        | Load impedance < 20 kohms, 1% THD, Note 4  |       | 3.1  |       | $V_{Pk}$ |
| Output offset voltage, $\Delta V_{TX}$  |          |  |       |      |       |          |
| PBL 3767  |          |  | -40   |      | +40   | mV       |
| PBL 3767/6  |          |  | -55   |      | +55   | mV       |
| Output impedance, $z_{TX}$  |          | 0.2 kHz < f < 3.4 kHz  |       | <5.0 | 20    | ohm      |
| <b>Four-wire receive port (RSN)</b>   |          |  |       |      |       |          |
| RSN dc voltage, $V_{RSN}$   |          | $I_{RSN} = 0$  |       | 0    |       | V        |
| RSN impedance, $z_{RSN}$  |          | 0.3 kHz < f < 3.4 kHz  |       | <5   | 20    | ohm      |
| RSN current ( $I_{RSN}$ ) to metallic loop current ( $I_L$ ) gain, $\alpha_{RSN}$ |          | 0.3 kHz < f < 3.4 kHz  |       | 1000 |       | ratio    |
| <b>Frequency response</b>   |          |  |       |      |       |          |
| Two-wire to four-wire, $g_{2-4}$  | 6        | 0.3 kHz < f < 3.4 kHz relative to 0 dBu, 1.0 kHz. $E_{RX} = 0$ V   | -0.1  | 0    | +0.1  | dB       |
| Four-wire to two-wire, $g_{4-2}$  | 6        | 0.3 kHz < f < 3.4 kHz relative to 0 dBu, 1.0 kHz. $E_L = 0$ V  | -0.1  | 0    | +0.1  | dB       |
| Four-wire to four-wire, $g_{4-4}$   | 6        | 0.3 kHz < f < 3.4 kHz relative to 0 dBu, 1.0 kHz. $E_L = 0$ V  | -0.1  | 0    | +0.1  | dB       |
| <b>Insertion loss</b>   |          |  |       |      |       |          |
| Two-wire to four-wire, $G_{2-4}$  | 6        | 0 dBm, 1.0 kHz, Note 5   |       |      |       |          |
| PBL 3767  |          |  | -0.20 | 0    | +0.20 | dB       |
| PBL 3767/6  |          |  | -0.25 | 0    | +0.25 | dB       |
| Four-wire to two-wire, $G_{4-2}$  | 6        | 0 dBm, 1.0 kHz, Notes 5, 6   |       |      |       |          |
| PBL 3767  |          |  | -0.20 | 0    | +0.20 | dB       |
| PBL 3767/6  |          |  | -0.25 | 0    | +0.25 | dB       |
| Four-wire to four-wire, $G_{4-4}$   | 6        | 0 dBm, 1.0 kHz, Notes 5, 6   | -0.3  | 0    | +0.3  | dB       |

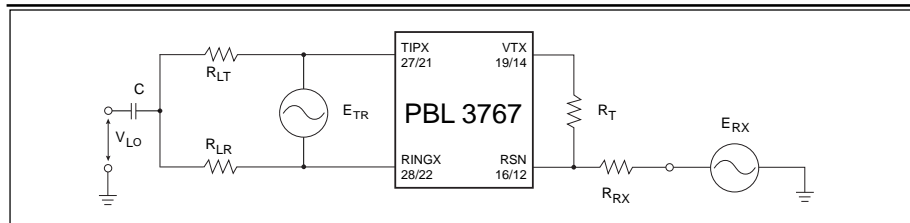

Figure 4. Metallic to longitudinal ( $B_{MLE}$ ) and four-wire to longitudinal ( $B_{FLE}$ ) balance.

$$\frac{1}{\omega C} \ll 150 \text{ ohms}, R_{LR} = R_{LT} = 300 \text{ ohms},$$

$$R_T = 600 \text{ kohms}, R_{RX} = 300 \text{ kohms}$$

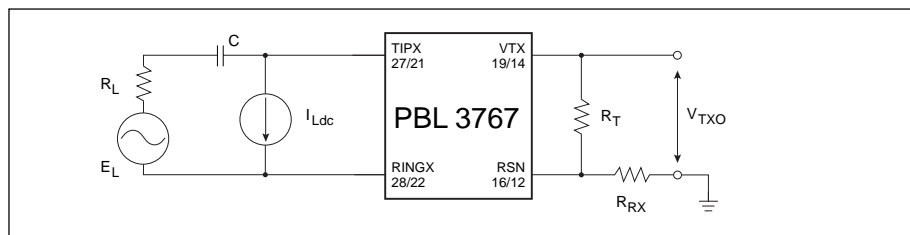

Figure 5. Overload level,  $V_{TXO}$ , four-wire transmit port.

$$\frac{1}{\omega C} \ll R_L, R_L = 600 \text{ ohms},$$

$$R_T = 600 \text{ kohms}, R_{RX} = 300 \text{ kohms}$$

| Parameter   | Ref Fig. | Conditions   | Min                  | Typ            | Max                 | Unit         |
|---|----------|--|----------------------|----------------|---------------------|--------------|
| <b>Gain tracking</b>  |          |  |                      |                |                     |              |
| Two-wire to four-wire   | 6        | Ref. -10 dBm, 1.0 kHz, Note 7<br>-40 dBm to +7 dBm<br>-55 dBm to -40 dBm   | -0.15                | ±0.03<br>±0.03 | +0.15               | dB<br>dB     |
| Four-wire to two-wire   | 6        | Ref. -10 dBm, 1.0 kHz, Note 8<br>-40 dBm to +7 dBm<br>-55 dBm to -40 dBm   | -0.15                | ±0.03<br>±0.03 | +0.15               | dB<br>dB     |
| <b>Noise</b>  |          |  |                      |                |                     |              |
| Idle channel noise at two-wire (TIPX-RINGX) or four-wire (VTX) port                       |          | Note 9<br>Psophometrical weighting<br>C-message weighting  |                      | -83<br>7       | -78<br>12           | dBmp<br>dBmC |
| <b>Harmonic distortion</b>  |          |  |                      |                |                     |              |
| Two-wire to four-wire,<br>Four-wire to two-wire   |          | 0.3 kHz < f < 3.4 kHz<br>0 dBm, 1.0 kHz test signal  |                      | -65            | -54                 | dB           |
| <b>Battery feed characteristics</b>   |          |  |                      |                |                     |              |
| Apparent battery voltage, E <sub>Bat</sub>  |          |  |                      | 50             |                     | V            |
| Conversion factor, K <sub>1</sub>   |          |  | 48                   | 50             | 52                  | ratio        |
| Feed resistance (R <sub>Feed</sub> ) to programming resistance (20 kΩ + R <sub>DC</sub> ) |          | $R_{Feed} = \frac{20 \cdot 10^3 + R_{DC}}{K_1}$  |                      |                |                     |              |
| Stand-by state loop current, I <sub>L</sub> , tolerance range                             |          | Stand-by state, C2, C1 = 1, 0<br>$I_L = \frac{ V_{Bat}  - 3}{R_L + 1800}$<br>V <sub>Bat</sub> tol. ±5%, T <sub>Amb</sub> = 25 °C | 0.75·I <sub>L</sub>  | I <sub>L</sub> | 1.25·I <sub>L</sub> | A            |
| <b>Loop current detector</b>  |          |  |                      |                |                     |              |
| On-hook to off-hook threshold, I <sub>LThOff</sub>  |          | R <sub>D</sub> = ∞, Note 10  |                      | 8.0            |                     | mA           |
| Off-hook to on-hook threshold, I <sub>LThOn</sub>   |          | R <sub>D</sub> = ∞, Note 10  |                      | 7.3            |                     | mA           |
| Detector threshold hysteresis, ∂I <sub>LTh</sub>  |          |  |                      | 0.7            |                     | mA           |
| Loop current detector conversion factor On-hook to off-hook, K <sub>LThOff</sub>          |          | $I_{LThOff} = K_{LThOff} \cdot \left[ \frac{1}{R_D} + \frac{1}{62500} \right]$<br>Note 11  | 375                  | 500            | 660                 | V            |
| Loop current detector conversion factor off-hook to on-hook, K <sub>LThOn</sub>           |          | $I_{LThOn} = K_{LThOn} \cdot \left[ \frac{1}{R_D} + \frac{1}{62500} \right]$<br>Note 11  |                      | 455            |                     | V            |
| <b>Ring trip detector</b>   |          |  |                      |                |                     |              |
| Offset voltage, ΔV <sub>DTR</sub>   |          | Source resistance, R <sub>S</sub> = 0  | -25                  |                | 25                  | mV           |
| Input bias current, I <sub>DT</sub>   |          | V <sub>Bat</sub> < V <sub>DT</sub> < 0 V   | -300                 | -100           |                     | nA           |
| Input common mode range, V <sub>DT</sub>  |          |  | V <sub>Bat</sub> + 1 |                | -2                  | V            |
| <b>Ring relay driver</b>  |          |  |                      |                |                     |              |
| On-state voltage, V <sub>RRly</sub>   |          | I <sub>RRly</sub> = 25 mA  | -0.5                 | -0.2           |                     | V            |
| Off state leakage current, I <sub>RRly</sub>  |          | V <sub>Bat</sub> < V <sub>RRly</sub> < 0   |                      |                | 10                  | μA           |

Figure 6. Frequency response, insertion loss, gain tracking.

$$\frac{1}{\omega C} \ll R_L, R_L = 600 \text{ ohms,}$$

$$R_T = 600 \text{ kohms, } R_{RX} = 300 \text{ kohms}$$

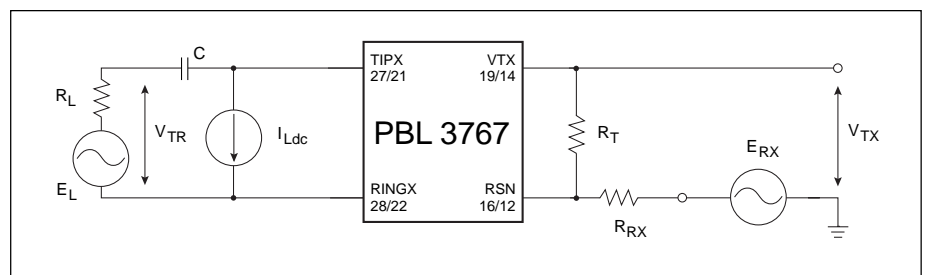

| Parameter                                       | Ref. Fig. | Conditions  | Min  | Typ  | Max      | Unit           |
|---|-----------|---|------|------|----------|----------------|
| <b>Digital inputs (C1, C2, E0)</b>              |           |   |      |      |          |                |
| Input low voltage, $V_{IL}$                     |           |   | 0    |      | 0.8      | V              |
| Input high voltage, $V_{IH}$                    |           |   | 2.0  |      | $V_{CC}$ | V              |
| Input low current, $I_{IL}$                     |           | $V_{IL} = 0.4$ V  |      |      |          |                |
| C1, C2  |           |   | -200 |      |          | $\mu$ A        |
| E0  |           |   | -100 |      |          | $\mu$ A        |
| Input high current, $I_{IH}$                    |           | $V_{IH} = 2.4$ V  |      |      | 40       | $\mu$ A        |
| <b>Digital output (DET)</b>                     |           |   |      |      |          |                |
| Output low voltage, $V_{OL}$                    |           | $I_{OL} = 2$ mA, E0 = 0   |      | 0.4  | 0.6      | V              |
| Output high voltage, $V_{OH}$                   |           | $I_{OH} = -100$ $\mu$ A, E0 = 0                                       | 2.7  |      |          | V              |
| Internal pull-up resistor                       |           |   | 10   | 15   | 20       | kohm           |
| DET short circuit current, $I_{ODs}$            |           | E0 = 1, $\overline{DET}$ shorted to ground                            |      | -330 |          | $\mu$ A        |
| <b>Power supply rejection ratio (PSRR)</b>      |           |   |      |      |          |                |
| To two-wire or four-wire port, from             |           | Note 12   |      |      |          |                |
| $V_{CC}$ , PSRR <sub>CC</sub>                   |           | 50 Hz $\leq f \leq 4$ kHz   | 30   | 35   |          | dB             |
|   |           | 4 kHz $\leq f \leq 50$ kHz  | 30   | 35   |          | dB             |
| $V_{EE}$ , PSRR <sub>EE</sub>                   |           | 50 Hz $\leq f \leq 4$ kHz   | 30   | 35   |          | dB             |
|   |           | 4 kHz $\leq f \leq 50$ kHz  | 12   | 18   |          | dB             |
| $V_{Bat}$ , PSRR <sub>Bat</sub>                 |           | 50 Hz $\leq f \leq 4$ kHz   | 40   | 50   |          | dB             |
|   |           | 4 kHz $\leq f \leq 50$ kHz  | 30   | 35   |          | dB             |
| <b>Power supply currents (relay driver off)</b> |           |   |      |      |          |                |
| $V_{CC}$ current, $I_{CC}$                      |           | Open circuit state  |      | 1    |          | mA             |
| $V_{EE}$ current, $I_{EE}$                      |           | C2, C1 = 0, 0   |      | 1    |          | mA             |
| $V_{Bat}$ current, $I_{Bat}$                    |           | On-hook   |      | 0.5  |          | mA             |
| $V_{CC}$ current, $I_{CC}$                      |           | Stand-by state  |      | 2    |          | mA             |
| $V_{EE}$ current, $I_{EE}$                      |           | C2, C1 = 1, 1   |      | 1    |          | mA             |
| $V_{Bat}$ current, $I_{Bat}$                    |           | On-hook   |      | 0.5  |          | mA             |
| $V_{CC}$ current, $I_{CC}$                      |           | Active state  |      | 4    |          | mA             |
| $V_{EE}$ current, $I_{EE}$                      |           | C2, C1 = 1, 0   |      | 2    |          | mA             |
| $V_{Bat}$ current, $I_{Bat}$                    |           | On-hook   |      | 3    |          | mA             |
| <b>Power dissipation</b>                        |           |   |      |      |          |                |
| Open circuit state total dissipation, $P_{Op}$  |           | C2, C1 = 0, 0<br>On-hook ( $R_L = \infty$ ) or off-hook ( $R_L = 0$ ) |      | 25   | 35       | mW             |
| Stand-by state total dissipation, $P_{OnSb}$    |           | C2, C1 = 1, 1<br>On-hook ( $R_L = \infty$ )                           |      | 35   | 45       | mW             |
| Active state total dissipation, $P_{OnAct}$     |           | C2, C1 = 1, 0<br>On-hook ( $R_L = \infty$ )                           |      | 160  | 220      | mW             |
| Active state total dissipation,                 |           | C2, C1 = 1, 0, Note 13  |      |      |          |                |
| $P_{OffAct200}$                                 |           | Off-hook, $R_L = 200$ ohm   |      | 1.25 | 1.40     | W              |
| $P_{OffAct600}$                                 |           | Off-hook, $R_L = 600$ ohm   |      | 1.00 | 1.20     | W              |
| <b>Temperature guard</b>                        |           |   |      |      |          |                |
| Junction temperature at threshold, $T_{JG}$     |           |   | 145  | 160  | 170      | $^{\circ}$ C   |
| Temperature guard hysteresis, $\partial T_{JG}$ |           |   |      | 20   |          | $^{\circ}$ C   |
| <b>Thermal resistance</b>                       |           |   |      |      |          |                |
| 28-pin PLCC, $\theta_{JP28plcc}$                |           | Junction to terminals 3, 6, 10, 17, 24 connected together, Note 14    |      | 10   | 15       | $^{\circ}$ C/W |
| 22-pin plastic DIP, $\theta_{JP22dip}$          |           | Junction to terminals 5, 6, 17, 18 connected together, Note 14        |      | 10   | 15       | $^{\circ}$ C/W |

## Notes

1. The overload level is specified at the two-wire port with the signal source at the four-wire receive port.
2. The two-wire impedance is programmable by selection of external component values according to:

$$Z_{\text{TRX}} = Z_{\text{T}} / |G_{2-4} \cdot \alpha_{\text{RSN}}|$$

where

$Z_{\text{TRX}}$  = impedance between the TIPX and RINGX terminals

$Z_{\text{T}}$  = programming network between the VTX and RSN terminals

$G_{2-4}$  = TIPX - RINGX to VTX gain, nominally = 1

$\alpha_{\text{RSN}}$  = receive current gain, nominally = -1000 (current defined as positive when flowing into the receive summing node, RSN and when flowing from TIPX to RINGX)

3. Higher return loss values can be achieved by adding a reactive component to  $R_{\text{T}}$ , the two-wire terminating impedance programming resistor, e.g. by dividing  $R_{\text{T}}$  into two equal halves and connecting a capacitor from the common point to ground. For  $R_{\text{T}} = 600$  kohms the capacitance value is approximately 33 pF.
4. The overload level is specified at the four-wire transmit port, VTX, with the signal source at the two-wire port. Note that the gain from the two-wire port to the four-wire transmit port is  $G_{2-4} = 1$ .
5. Fuse resistors  $R_{\text{F}}$  impact the insertion loss as explained in the text, section Transmission. The specified insertion loss is for  $R_{\text{F}} = 0$ .
6. The specified insertion loss tolerance does not include errors caused by external components.
7. The level is specified at the two-wire port.
8. The level is specified at the four-wire receive port and referenced to a 600 ohm impedance level.
9. The two-wire idle noise is specified with the port terminated in 600 ohms ( $R_{\text{L}} = 600$  ohms) and with the four-wire receive port grounded ( $E_{\text{RX}} = 0$ , see figure 6).  
The four-wire idle noise at VTX is specified with the two-wire port terminated in 600 ohms ( $R_{\text{L}} = 600$  ohms). The noise specification is with respect to a 600 ohm impedance level at VTX. The four-wire receive port is grounded ( $E_{\text{RX}} = 0$ , see figure 6).
10. With the RD terminal left open, the loop current detector on-hook to off-hook threshold is internally set to 8.0 mA and the off-hook to on-hook threshold to 7.3 mA. The loop current detection threshold can be set to higher values by connecting a resistor,  $R_{\text{D}}$ , between terminal RD and  $V_{\text{EE}}$  (-5 V), as described in section Loop Monitoring Functions.
11. Refer to section Loop Monitoring Functions, Loop Current Detector.
12. Power supply rejection ratio test signal is 100 mVrms (sinusoidal).
13. Line resistor  $R_{\text{F}} = 0$  ohm.
14. Junction to ambient thermal resistance will be dependent on external thermal resistance from VBAT terminals to ambient.

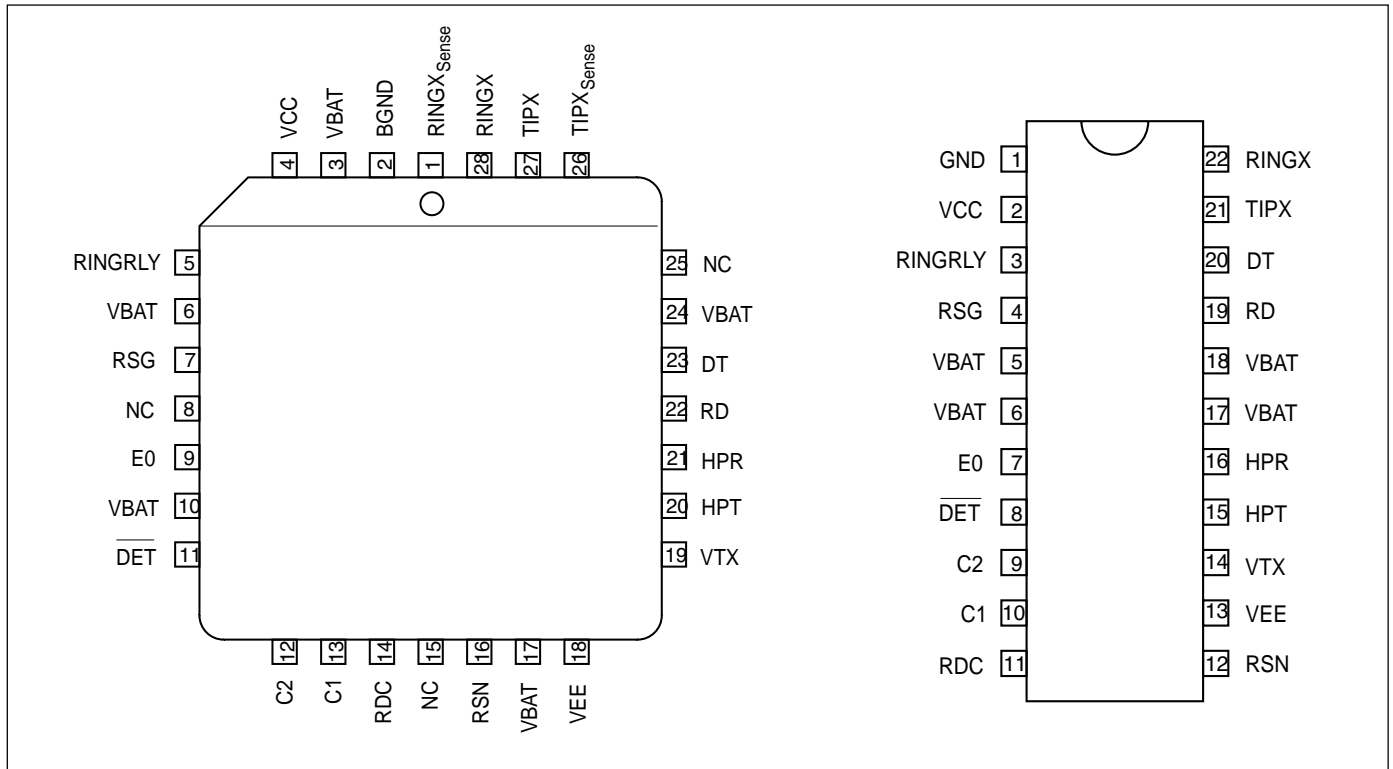

Figure 7. Pin configuration, 28-pin plastic ledged chip carrier and 22-pin plastic dual-in-line package, top view.

## Pin Description

PLCC: 28-pin, plastic, j-ledged chip carrier. DIP: 22-pin, dual-in-line (batwing), plastic package. Refer to figure 7.

| PLCC | DIP | Symbol | Description |
|------|-----|--------|-------------|
|------|-----|--------|-------------|

|                                  |                 |                        |   |
|----------------------------------|-----------------|------------------------|---|
| 1                                | -               | RINGX <sub>Sense</sub> | RINGX <sub>Sense</sub> is internally connected to RINGX. RINGX <sub>Sense</sub> is used during manufacturing, but requires no connection in SLIC applications, i.e. leave open.   |
| 2                                | 1               | GND                    | Ground.   |
| 3                                | -               | VBAT                   | Refer to PLCC, terminal 6 description.  |
| 4                                | 2               | VCC                    | +5 V power supply.  |
| 5                                | 3               | RINGRLY                | Ring relay driver output. Open emitter with grounded collector (npn). Sources 50 mA from ground to a relay coil connected to a negative voltage. Must be protected by external inductive kick-back diode. Positive voltage relay driver can be provided as a metal mask option. Contact factory for availability. |
| 6, 3,<br>10, 17,<br>17, 18<br>24 | 5, 6,<br>17, 18 | VBAT                   | Battery supply voltage. Negative with respect to GND. -21 V to -58 V. All VBAT terminals should be connected to printed circuit board traces to provide heatsinking.  |
| 7                                | 4               | RSG                    | Saturation guard programming resistor, R <sub>SG</sub> , connects from this terminal to VEE. Leave open for nominal battery voltages from -24 V to -28 V. Connect to VEE for a nominal battery voltage of -48 V. For other battery voltages and for detailed information refer to section Battery Feed.           |
| 8                                | -               | NC                     | No internal connection. Note 1.   |
| 9                                | 7               | E0                     | TTL compatible enable input. Enables the $\overline{DET}$ output, when set to logic level low and disables the $\overline{DET}$ output, when set to logic level high. Refer to section Enable Input for detailed information.   |
| 10                               | -               | VBAT                   | Refer to PLCC, terminal 6 description.  |



| PLCC | DIP | Symbol                       | Description   |
|------|-----|------------------------------|---|
| 11   | 8   | $\overline{\text{DET}}$      | Detector output. Inputs C1 and C2 select one of the two detectors to be connected to the $\overline{\text{DET}}$ output. A logic low level at the enabled (refer to E0) $\overline{\text{DET}}$ output indicates a triggered detector condition. The $\overline{\text{DET}}$ output is open collector with internal pull-up resistor (approximately 15 kohms) to VCC. |
| 12   | 9   | C2                           | C1 and C2 are TTL compatible inputs controlling the SLIC operating states. Refer to section Control Inputs for details.   |
| 13   | 10  | C1                           |   |
| 14   | 11  | RDC                          | Dc loop feed is programmed by one resistor connected from this pin to the receive summing node (RSN). A decoupling capacitor, $C_{\text{DC}}$ , connected from RDC to GND removes noise and other ac signals from the battery feed control loop.  |
| 15   | -   | NC                           | No internal connection. Note 1.   |
| 16   | 12  | RSN                          | Receive summing node. 1000 times the current (dc and ac) flowing into this pin equals the metallic (transversal) current flowing from RINGX to TIPX. Programming networks for feed resistance, two-wire impedance and receive gain connect to the receive summing node.   |
| 17   | -   | VBAT                         | Refer to PLCC, terminal 6 description.  |
| 18   | 13  | VEE                          | -5V power supply.   |
| 19   | 14  | VTX                          | Transmit vf output. The ac voltage difference between TIPX and RINGX, the ac metallic voltage, is reproduced as an unbalanced GND referenced signal at VTX with a gain of one. The two-wire terminating impedance programming network connects between VTX and RSN.   |
| 20   | 15  | HPT                          | Tip side of ac/dc separation capacitor $C_{\text{HP}}$ . Other end of $C_{\text{HP}}$ connects to pin, HPR.   |
| 21   | 16  | HPR                          | Ring side of ac/dc separation capacitor $C_{\text{HP}}$ . Other end of $C_{\text{HP}}$ capacitor connects to pin, HPT.  |
| 22   | 19  | RD                           | Loop current detector programming resistor $R_{\text{D}}$ connects from RD to VEE. An optional filter capacitor $C_{\text{D}}$ may be connected between terminal RD and ground. With the RD pin left open, the loop current detect threshold is internally set to 8.0 mA. Refer to section Loop Monitoring Functions for additional information.                      |
| 23   | 20  | DT                           | DT is the non-inverting ring trip comparator input. The inverting comparator input is internally connected to VEE. With DT more negative than the inverting input, the detector output, $\overline{\text{DET}}$ , is at logic level low, indicating off-hook condition. The ring trip network connects to the DT input.   |
| 24   | -   | VBAT                         | Refer to PLCC, terminal 6 description.  |
| 25   | -   | NC                           | No internal connection. Note 1.   |
| 26   | -   | $\text{TIPX}_{\text{Sense}}$ | $\text{TIPX}_{\text{Sense}}$ is internally connected to TIPX. $\text{TIPX}_{\text{Sense}}$ is used during manufacturing, but requires no connection in SLIC applications, i.e. leave open.  |
| 27   | 21  | TIPX                         | The TIPX and RINGX pins connect to the tip and ring leads of the two-wire interface via overvoltage protection components and ring relay (and optional test relays).  |
| 28   | 22  | RINGX                        |   |

**Notes**

1. Terminals marked NC are not internally connected to the chip. These terminals may be connected to ground for shielding.

## Functional Description and Applications Information

### Transmission

#### General

A simplified ac model of the transmission circuits is shown in figure 8. Circuit analysis yields:

$$V_{TR} = V_{TX} + I_L \cdot 2R_F \quad (1)$$

$$\frac{V_{TX}}{Z_T} + \frac{V_{RX}}{Z_{RX}} = \frac{I_L}{1000} \quad (2)$$

$$V_{TR} = E_L - I_L \cdot Z_L \quad (3)$$

where

$V_{TX}$  is a ground referenced unity gain version of the ac metallic voltage between the TIPX and RINGX terminals, i.e.  $V_{TX} = 1 \cdot V_{TRX}$ .

$V_{TR}$  is the ac metallic voltage between tip and ring.

$E_L$  is the line open circuit ac metallic voltage.

$I_L$  is the ac metallic current.

$R_F$  is a current limiting resistor in the overvoltage protection network.

$Z_L$  is the line impedance.

$Z_T$  determines the SLIC TIPX to RINGX impedance.

$Z_{RX}$  controls four- to two-wire gain.

$V_{RX}$  is the analog ground referenced receive signal.

#### Two-wire Impedance

To calculate  $Z_{TR}$ , the impedance presented to the two-wire line by the SLIC including the fuse resistors  $R_F$ , let  $V_{RX} = 0$ .

From (1) and (2):

$$Z_{TR} = \frac{Z_T}{1000} + 2R_F$$

With  $Z_{TR}$  and  $R_F$  known  $Z_T$  may be calculated from

$$Z_T = 1000 \cdot (Z_{TR} - 2R_F)$$

Example: calculate  $Z_T$  to make the terminating impedance  $Z_{TR} = 600$  ohms in series with  $2.16 \mu\text{F}$ .  $R_F = 40$  ohms.

Using the expression above

$$Z_T = 1000 \cdot \left( 600 + \frac{1}{j\omega \cdot 2.16 \cdot 10^{-6}} - 2 \cdot 40 \right)$$

i.e.  $Z_T = 520$  kohms in series with  $2.16$  nF. It is always necessary to have a high ohmic resistor in parallel with the capacitor. This gives a DC-feedback loop for

low frequency which ensures stability and reduces noise.

#### Two-wire to Four-wire Gain

The two-wire to four-wire gain,  $G_{2-4}$ , is obtained from (1) and (2) with  $V_{RX} = 0$ :

$$G_{2-4} = \frac{V_{TX}}{V_{TR}} = \frac{Z_T/1000}{Z_T/1000 + 2R_F}$$

#### Four-wire to Two-wire Gain

The four-wire to two-wire gain,  $G_{4-2}$ , is derived from (1), (2) and (3) with  $E_L = 0$ :

$$G_{4-2} = \frac{V_{TR}}{V_{RX}} = - \frac{Z_T}{Z_{RX}} \cdot \frac{Z_L}{Z_T/1000 + 2R_F + Z_L}$$

#### Four-wire to Four-wire Gain

The four-wire to four-wire gain,  $G_{4-4}$ , is derived from (1), (2) and (3) with  $E_L = 0$ :

$$G_{4-4} = \frac{V_{TX}}{V_{RX}} = - \frac{Z_T}{Z_{RX}} \cdot \frac{Z_L + 2R_F}{Z_T/1000 + 2R_F + Z_L}$$

#### Hybrid Function

The PBL 3767 SLIC forms a particularly flexible and compact line interface when used with programmable CODEC/filters. The programmable CODEC/filters allow for system controller adjustment of hybrid balance to accommodate different line impedances without change of hardware. It also permits the system controller to adjust transmit and receive gains as well as terminating impedance. Refer to programmable CODEC/filter data sheets for design information.

The hybrid function in an implementation utilizing the uncommitted amplifier in a conventional CODEC/filter combination is shown in figure 9. Via impedance  $Z_B$  a current proportional to  $V_{RX}$  is injected into the summing node of the combination CODEC/filter amplifier. As can be seen from the expression for the four-wire to four-wire gain a voltage proportional to  $V_{RX}$  is returned to  $V_{TX}$ . This voltage is converted by  $R_{TX}$  to a current into the same summing node. These currents can be made to cancel by letting:

$$\frac{V_{TX}}{R_{TX}} + \frac{V_{RX}}{Z_B} = 0 \quad (E_L = 0)$$

Substituting the four-wire to four-wire gain expression,  $G_{4-4}$ , for  $V_{RX}/V_{TX}$  yields the formula for a balanced network:

$$Z_B = -R_{TX} \cdot \frac{V_{RX}}{V_{TX}} = R_{TX} \cdot \frac{Z_{RX}}{Z_T} \cdot \frac{Z_T/1000 + 2R_F + Z_L}{Z_L + 2R_F}$$

Example:  $Z_{TR} = Z_L = 600$  ohms ( $R_L$ ) in series with  $2.16 \mu\text{F}$  ( $C_L$ ),  $R_F = 40$  ohms,  $R_{TX} = 20$  kohms,  $G_{4-2} = -1$ . Calculate  $Z_B$ . Using the  $Z_B$  formula above:

$$Z_B = \{Z_L = Z_{TR}\} = R_{TX} \cdot \frac{Z_{RX}}{Z_T} \cdot \frac{2Z_L}{Z_L + 2R_F} = \{G_{4-2} = -1\} = R_{TX} \cdot \frac{Z_L}{Z_L + 2R_F}$$

$$= R_{TX} \cdot \frac{1 + j\omega \cdot R_L \cdot C_L}{1 + j\omega \cdot (R_L + 2R_F) \cdot C_L}$$

A network consisting of  $R_{B1}$  in series with the parallel combination of  $R_B$  and  $C_B$  has the same form as the required balance network,  $Z_B$ . Basic algebra yields:

$$R_{B1} = R_{TX} \cdot \frac{R_L}{R_L + 2R_F} = 17.6 \text{ kohms}$$

$$R_B = R_{TX} \cdot \frac{2R_F}{R_L + 2R_F} = 1353 \text{ ohms}$$

$$C_B = \frac{(R_L + 2R_F) \cdot C_L}{R_{TX} \cdot 2R_F} = 0.62 \mu\text{F}$$

#### Longitudinal Impedance

In the active state, a feedback loop counteracts longitudinal voltages at the two-wire port by injecting longitudinal currents in opposing phase. Therefore longitudinal disturbances will appear as longitudinal currents and the TIPX and RINGX terminals will experience very small longitudinal voltage excursions, well within the SLIC common mode range. This is accomplished by comparing the instantaneous two-wire longitudinal voltage to an internal reference voltage,  $V_{Bal}/2$ . As shown below, the SLIC appears as 20 ohms to ground per wire to longitudinal disturbances. It should be noted, that longitudinal currents may exceed the dc loop current without disturbing the transmission. From figure 10 the longitudinal impedance can be calculated:

$$\frac{V_{Lo}}{I_{Lo}} = \frac{R_{Lo}}{1000} = 20 \text{ ohms}$$

where

$V_{Lo}$  is the longitudinal voltage

$I_{Lo}$  is the longitudinal current

$R_{Lo} = 20$  kohms sets the longitudinal impedance

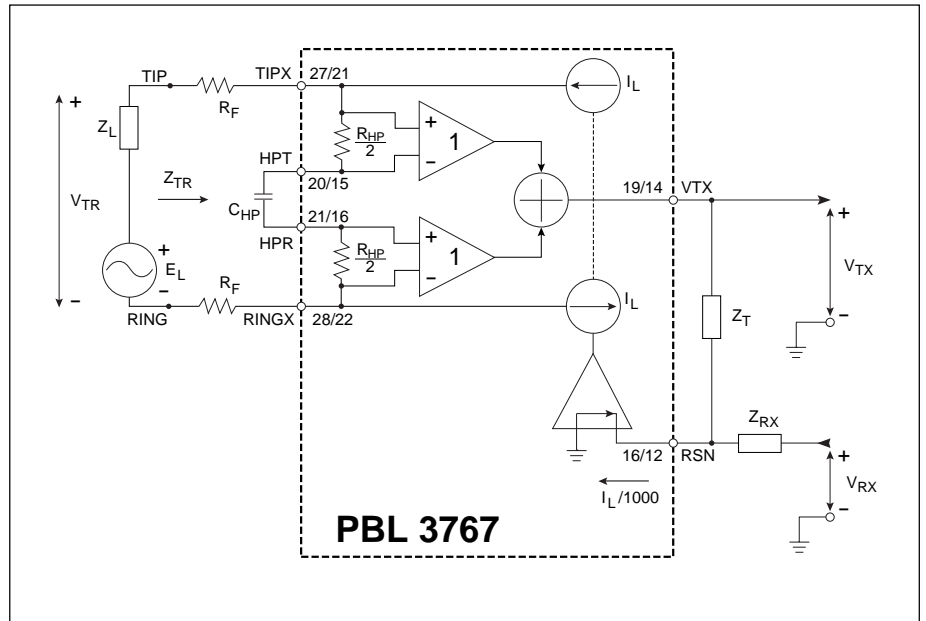

Figure 8. Simplified ac transmission circuit.

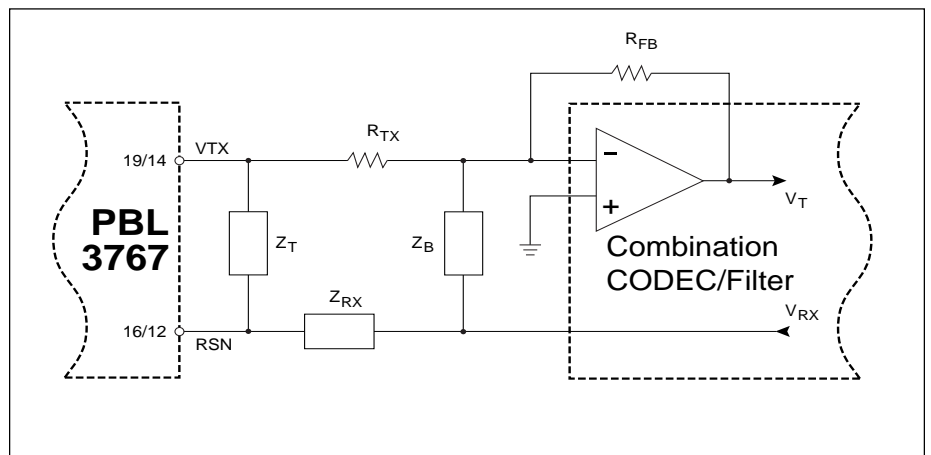

Figure 9. Hybrid function.

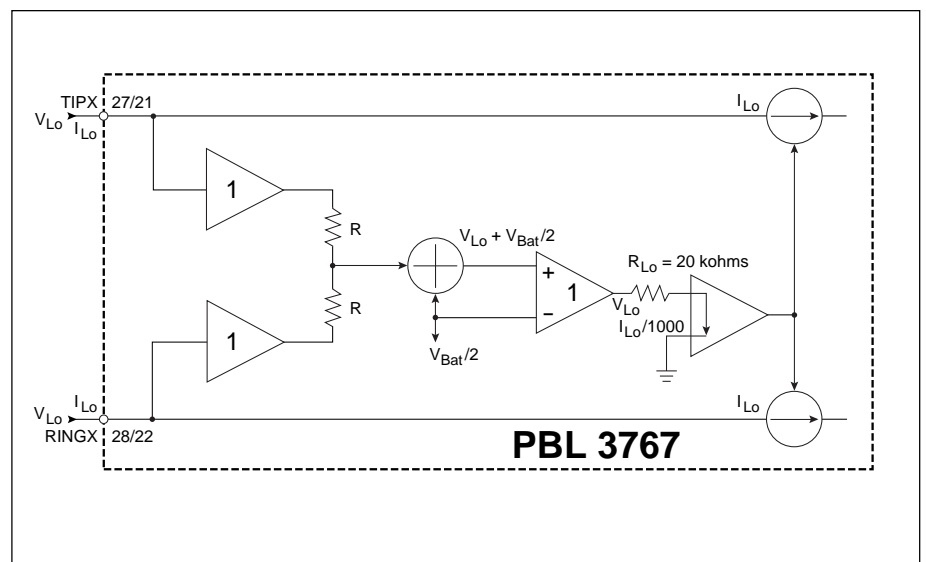

Figure 10. Longitudinal feedback loop.

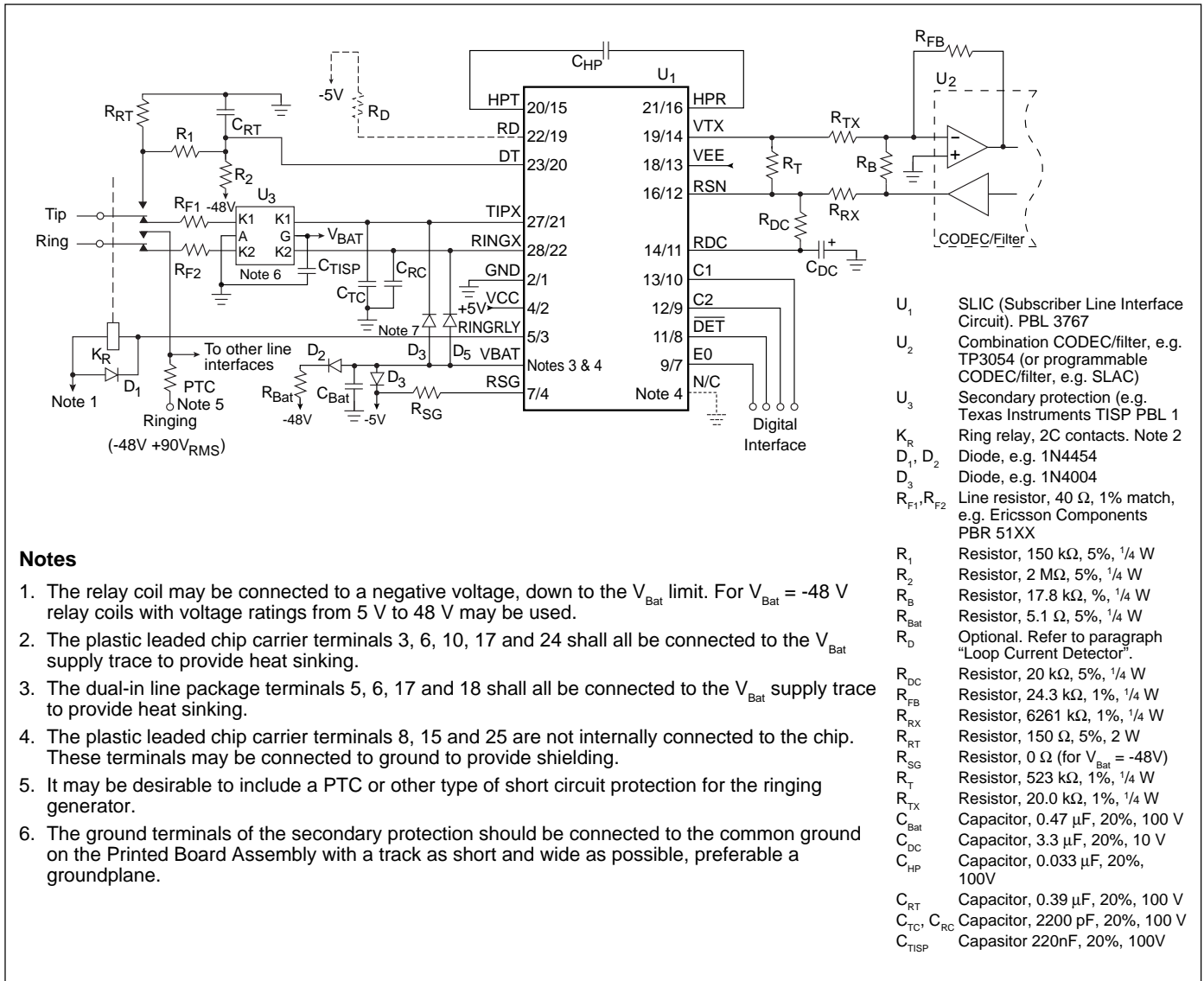

Figure 11. Single channel subscriber line interface with PBL 3767 and a combination CODEC/filter.

**Capacitors  $C_{TC}$  and  $C_{RC}$**

The capacitors designated  $C_{TC}$  and  $C_{RC}$  in figure 11, connected between TIPX and ground as well as between RINGX and ground, are recommended as an addition to the overvoltage protection network. Very fast transients, appearing on tip and ring, may pass by the diode and SCR clamps in the overvoltage protection network, before these devices have had time to activate and could damage the SLIC.  $C_{TC}$  and  $C_{RC}$  short such very fast transients to ground. The recommended value for  $C_{TC}$  and  $C_{RC}$  is 2200 pF. Higher capacitance values may be used, but care must be taken to prevent degradation of either longitudinal balance or return loss.  $C_{TC}$  and  $C_{RC}$

contribute a metallic impedance of  $1/(\pi \cdot f \cdot C_{TC}) \approx 1/(\pi \cdot f \cdot C_{RC})$ , a TIPX to ground impedance of  $1/(2 \cdot \pi \cdot f \cdot C_{TC})$  and a RINGX to ground impedance of  $1/(2 \cdot \pi \cdot f \cdot C_{RC})$ .

**Ac - Dc Separation Capacitor,  $C_{HP}$**

The high pass filter capacitor connected between terminals HPT and HPR provides the separation between circuits sensing tip-ring dc conditions and circuits processing ac signals. A  $C_{HP}$  value of 33 nF will position the low end frequency response 3dB break point at 12 Hz ( $f_{3dB}$ ) according to  $f_{3dB} = 1/(2\pi \cdot R_{HP} \cdot C_{HP})$  where  $R_{HP} \approx 400$  k $\Omega$ .

**Battery Feed**

**Overview**

The PBL 3767 SLIC emulates a resistive battery feed system with loop current limiting on short loops. The block diagram in figure 12 shows the basic PBL 3767 active state battery feed system (short loop current limiting not shown.)

The emulated battery feed is a 50 V source in series with a programmable feed resistance. The apparent 50 V battery is independent of the actual supply voltage connected to the SLIC. The feed resistance value is set by an external programming resistor,  $R_{DC}$ . For short loops the battery feed reverts to quasi constant current.

To permit the line drive amplifiers to operate without vf signal distortion even on high resistance or open circuit loops, a saturation guard circuit limits the loop voltage, when the tip to ring dc voltage approaches the available battery supply voltage.

Figure 13 shows an example of PBL 3767 active state battery feed.

With the SLIC set to the stand-by state, most of the circuit is disabled, including the line drive amplifiers, to conserve power. A 2 x 900 ohm resistive feed substitutes for the active state battery feed.

The following paragraphs describe the PBL 3767 battery feed system in detail.

**Case 1: SLIC in the Active State**

$$V_{TRdc} < V_{SGRef}, I_{Ldc} < 760/(20000 + R_{DC})$$

In the active state C1 = 0 and C2 = 1. In this operating state tip to ring voltages  $V_{TR}$  less than  $V_{SGRef}$  cause the block titled saturation guard in figure 12 to be disabled, i.e. its output is equal to zero. For this case circuit analysis yields:

$$V_{TR} = 50 \cdot \frac{R_L}{R_L + (R_{DC} + 20000)/50}$$

where

$R_L$  = the line resistance.

$R_{DC}$  = the programming resistance which sets the equivalent feed resistance,  $R_{Feed} = (R_{DC} + 20000)/50$ .

$V_{TR}$  = the tip to ring dc metallic voltage.

Note, that for simplicity the fuse resistors  $R_F$  have not been included.

When the desired feed resistance is known,  $R_{DC}$  is calculated from

$$R_{DC} = 50 \cdot R_{Feed} - 20000$$

For tip to ring voltages  $V_{TR}$  less than  $V_{SGRef}$  and loop currents  $I_{Ldc} < 760/(20000 + R_{DC})$  the PBL 3767 thus emulates a resistive battery feed with 50 V apparent battery and a feed resistance equal to  $(R_{DC} + 20000)/50$ .

Capacitor  $C_{DC}$ , connected between the RDC terminal and ground removes noise and vf signals from the battery feed control loop.  $C_{DC}$  is calculated according to

$$C_{DC} = \frac{1}{2\pi \cdot f_{DC}} \cdot \left[ \frac{1}{20000} + \frac{1}{R_{DC}} \right]$$

where

$f_{DC}$  = 5 Hz

$R_{DC}$  = feed bridge programming resistance in ohms

$C_{DC}$  = filter capacitor in farads

**Case 2: SLIC in the Active State**

$$V_{TRdc} < V_{SGRef}, 760/(20000 + R_{DC}) < I_{Ldc} < 1200/(20000 + R_{DC})$$

In the active state C1 = 0 and C2 = 1. In this operating range the battery feed circuit reverts to quasi constant current feed with a short circuit loop current

$$I_{Ldc} = 1200/(20000 + R_{DC})$$

where  $I_{Ldc}$  is in amperes for  $R_{DC}$  in ohms.

The quasi constant current feed curve is entered when the loop current exceeds

$$I_{Ldc} = 760/(20000 + R_{DC})$$

where  $I_{Ldc}$  is in amperes for  $R_{DC}$  in ohms.

**Case 3: SLIC in the Active State**

$$V_{TRdc} > V_{SGRef}, I_{Ldc} < 760/(20000 + R_{DC})$$

In the active state C1 = 0 and C2 = 1. When the tip to ring dc voltage approaches the  $V_{Bat}$  supply voltage, a circuit named saturation guard limits the two-wire voltage to a small additional increase beyond the saturation guard threshold,  $V_{SGRef}$ . This leaves a sufficient voltage margin to the  $V_{Bat}$  supply to maintain distortion free vf transmission through the line drive amplifiers. The saturation guard feature makes on-hook transmission possible.

The tip to ring voltage at which the saturation guard becomes active,  $V_{SGRef}$ , can be calculated from

$$V_{SGRef} = 12.5 + \frac{5 \cdot 10^5}{22.0 \cdot 10^3 + R_{SG}}$$

where

$V_{SGRef}$  is in volts for  $R_{SG}$  in ohms

$R_{SG}$  is a resistor connected between terminal RSG and -5 V.

$R_{SG}$  = open circuit yields  $V_{SGRef} = 12.5$  V

$R_{SG} = 0$  ohm yields  $V_{SGRef} = 35.2$  V

The loop voltage,  $V_{TRdc}$ , as a function of the loop resistance,  $R_L$ , for  $V_{TRdc} > V_{SGRef}$  is described by

$$V_{TRdc} = \frac{15.38 + 4.62 \cdot 10^5 / (22000 + R_{SG})}{R_L + (R_{DC} + 20000) / 650} \cdot R_L$$

from which the open loop voltage ( $I_L = 0$ ) is calculated to

$$V_{TRdc} = 15.38 + \frac{4.62 \cdot 10^5}{22000 + R_{SG}}$$

For  $R_{SG}$  = open circuit, the open circuit tip to ring dc voltage is 15.4 V, which is compatible with  $V_{Bat}$  in the -24 V to -28 V range.

For  $R_{SG} = 0$  ohm, the open circuit tip to ring dc voltage is 36.4 V, which is

compatible with  $V_{Bat}$  in the -42 V to -58 V range.

For intermediate battery voltage,  $V_{Bat}$ , values  $R_{SG}$  can be calculated from

$$R_{SG} = \frac{4.62 \cdot 10^5}{V_{TRdc} - 15.38} - 22000$$

where

$R_{SG}$  is in ohms for  $V_{TRdc}$  in volts

$V_{TRdc}$  is the open loop tip to ring voltage.

Let  $V_{TRdc} = |V_{Bat}| - 8$  V to allow distortion free transmission of a 3.1 Vpk vf signal in the on-hook mode. The 8 V margin may be reduced if a vf signal of less than 3.1 Vpk is to be transmitted in the on-hook mode.

**Case 4: SLIC in the Stand-by State**

In the stand-by state C1 = 1 and C2 = 1. With the SLIC operating in the stand-by, power saving state the tip and ring drive amplifiers are disconnected and a high resistance battery feed is engaged. The loop current can be calculated from

$$I_{Ldc} \approx \frac{|V_{Bat}| - 3 V}{R_L + 1800 \Omega}$$

where

$I_{Ldc}$  = loop current

$R_L$  = loop resistance

$V_{Bat}$  = battery supply voltage

-3 V = voltage drop across internal transistors

1800  $\Omega$  = feed resistance (900  $\Omega$  on the tip side, 900  $\Omega$  on the ring side)

**PBL 3767 Power Dissipation and Derating**

The tip to ring short circuit PBL 3767 total power dissipation,  $P_{ShTot}$  is

$$P_{ShTot} = I_{LSh} \cdot (|V_{Bat}| - I_{LSh} \cdot 2R_F) + P_{OnAct}$$

where

$I_{LSh} = 1080/(20000 + R_{DC})$  is the short circuit loop current

$P_{OnAct}$  is the active state on-hook dissipation, typically 160 mW.

The permissible maximum device dissipation is 1.5 W. The maximum allowable junction temperature is 140 °C for normal reliability requirements and 110 °C for extreme reliability requirements. The junction temperature is calculated from

$$T_J = P_{ShTot} \cdot (\theta_{JP} + \theta_{PA}) + T_{Amb}, T_J < 140 \text{ } ^\circ\text{C}$$

where

$\theta_{JP} = \theta_{JP28p1cc} = \theta_{JP22dip}$  is the thermal

resistance from junction to all VBAT terminals, typically 10 °C/W.

$\theta_{PA}$  is the thermal resistance from all VBAT terminals to ambient. The  $\theta_{PA}$  value will be dependent on line-card thermal design.

$T_{Amb}$  is the ambient temperature in °C.

## Loop Monitoring Functions

### Overview

The PBL 3767 SLIC contains detectors for loop current and ring trip. These two detectors report their status via the shared  $\overline{DET}$  output. A triggered detector is indicated by a logic low level at the  $\overline{DET}$  output. The detector to be connected to the  $\overline{DET}$  output is selected via the control interface C1 and C2. Refer to section Control Inputs for a description of the control interface. Enable input E0 sets the  $\overline{DET}$  output to either active or high impedance state.

### Loop Current Detector

The loop current detector is connected to the  $\overline{DET}$  output in the stand-by (C2, C1 = 1, 1) and the active (C2, C1 = 1, 0) states. Refer to figure 14.

The loop current value,  $I_{LThOff}$ , at which the loop current detector changes from indicating on-hook to indicating off-hook is internally programmed to 8.0 mA. The internally set loop current detector threshold,  $I_{LThOn}$ , for the off-hook to on-hook transition is 7.3 mA.

An external resistor,  $R_D$ , may be connected from terminal RD to  $V_{EE}$  to increase the loop current detector thresholds. When the desired on-hook to off-hook loop current threshold,  $I_{LThOff}$ , is known, the  $R_D$  value is calculated from

$$R_D = \frac{1}{I_{LThOff}/500 - 1/62500}$$

where  $R_D$  is in ohms for  $I_{LThOff}$  in amperes.

The off-hook to on-hook loop current detector threshold,  $I_{LThOn}$ , for the selected  $R_D$  value is calculated from

$$I_{LThOn} = K_{LThOn} \cdot \left[ \frac{1}{R_D} + \frac{1}{62500} \right]$$

where

$I_{LThOn}$  is in amperes for  $R_D$  in ohms.

$I_{LThOn} > 7.3$  mA,  $K_{LThOn} = 455$  V

The on-hook to off-hook loop current detector threshold,  $I_{LThOff}$ , for a specific  $R_D$  value is calculated from

$$I_{LThOff} = K_{LThOff} \cdot \left[ \frac{1}{R_D} + \frac{1}{62500} \right]$$

where

$I_{LThOff}$  is in amperes for  $R_D$  in ohms.

$I_{LThOff} > 8.0$  mA,  $K_{LThOff} = 500$  V

During dial pulsing the loop current detector is aided by a speed-up circuit, acting on the RDC output at loop closures. The speed-up circuit will charge the  $C_{DC}$  capacitor at a more rapid rate than that set by the  $(C_{DC} \cdot R_{DC} \cdot 20000)/(R_{DC} + 20000)$  time constant, resulting in the loop current reaching the detector threshold value faster and therefore minimizing dial pulse distortion.

### Loop Current Detector - Filter Capacitor

To increase the loop current detector noise immunity, a filter capacitor may be added from terminal RD to ground. A suggested value for  $C_D$  is

$$C_D = \frac{R_D + 62500}{2\pi \cdot (R_D \cdot 62500) \cdot f_{3dB}}$$

where

$C_D$  is in farads for  $R_D$  in ohms  $f_{3dB} = 500$  Hz

Note that  $C_D$  may not be required if the  $\overline{DET}$  output is software filtered.

### Ring Trip Detector

Ring trip detection is accomplished by monitoring the two-wire line for presence of dc current while ringing is applied. When the subscriber goes off-hook during ringing, dc loop current starts to flow. The SLIC ring trip comparator detects this current flow via an interface network. The DT comparator input is connected to pin 23/20. The other comparator input is internally connected to  $V_{EE}$ . The result of the comparison is presented at the  $\overline{DET}$  output with logic low level indicating off-hook. The ring trip comparator is automatically connected to the  $\overline{DET}$  output, when the SLIC control inputs are set to the ringing state (C2, C1 = 0, 1). When off-hook during ringing is detected, the line card or system controller will proceed to disconnect the ringing source (software ringtrip) by resetting the control input logic states. Alternatively, the  $\overline{DET}$  output may be monitored by circuits on the line card, which perform the ringtrip function (hardware ringtrip).

The ringing source may be balanced or unbalanced, superimposed on the  $V_{Bat}$  supply voltage. A ring relay, energized by the SLIC ring relay driver, connects the ringing source to tip and ring. For unbal-

anced ringing systems the loop current sensing resistor,  $R_{RT}$ , is placed in series with the return lead to ground.

Figures 15 and 16 show examples of unbalanced and balanced ringing systems. For either ringing system the ringtrip detection function is based on a polarity change at the inputs of the ringtrip comparator.

In the unbalanced case the dc voltage drop across resistor  $R_{RT}$  is zero, as long as the telephone remains on-hook. With the telephone off-hook during ringing, dc loop current will flow, causing a voltage drop across  $R_{RT}$ . The  $R_{RT}$  voltage is applied to the comparator input DT via resistor  $R_1$ .  $R_2$  shifts the voltage level to be compatible with the inverting input  $V_{EE}$  reference voltage.  $C_{RT}$  removes part of the ac component of the ringing signal.

The inverting comparator input is biased at  $V_{EE}$ , which is more negative than DT when the telephone is on-hook and is more positive than DT when the telephone goes off-hook during ringing.

Complete removal of the ringing signal ac component at the DT input is not necessary. Some residual ac component at the DT input may, under certain operating conditions, cause the  $\overline{DET}$  output to toggle between the on-hook and off-hook states at the ringing frequency. However, with the telephone off-hook, the  $\overline{DET}$  output will be at logic low level for more than half the time. Therefore, by sampling the  $\overline{DET}$  output, a software routine can discriminate between on-hook and off-hook through examination of the duty cycle. Full removal of the ringing frequency from the DT input, while maintaining ringtrip within required time limits (approximately < 100 ms), usually mandates a second order filter rather than the first order shown in figure 15. The software approach minimizes the number of line card components.

In the balanced ringing system shown in figure 16,  $R_{RT1}$  and  $R_{RT2}$  are the ringing feed and loop current sensing resistors. With the telephone on-hook, no dc loop current flows to cause a dc voltage drop across resistor  $R_{RT1}$ . Voltage divider  $R_1$ ,  $R_2$  and  $R_3$  biases the ringtrip comparator input DT to be more positive than  $V_{EE}$  during on-hook. With the telephone off-hook during ringing dc loop current will flow, causing a voltage drop across resistor  $R_{RT1}$ , which will make comparator input DT more negative than  $V_{EE}$ . This will set the  $\overline{DET}$  output to logic low level,

Figure 12. Battery feed (C2, C1 = 1, 0; active state).

$$V_{SGRef} = 12.5 + \frac{5 \cdot 10^5}{R_{SG} + 22 \text{ k}\Omega}$$

$$V_{SG} = -7.50 - \frac{3.0 \cdot 10^5}{R_{SG} + 22 \text{ k}\Omega}$$

**Note 1.** Loop current is limited for  $I_{Ldc} \geq 760 / (20000 + R_{DC})$ , and maximum loop current is  $I_{Ldcmax} = 1080 / (20000 + R_{DC})$ .

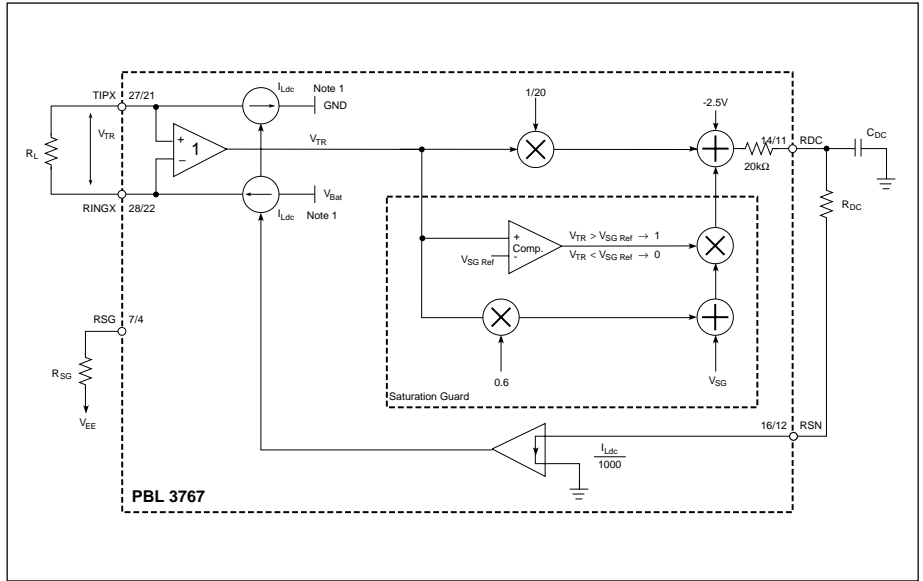

Figure 13. PBL 3767 loop feed example.

$R_{DC} = 20 \text{ kohms}$   
 $R_{SG} = 0 \text{ ohms (connected to } V_{EE})$   
 $V_{Bat} = -58 \text{ V to } -42 \text{ V}$   
 $T_{Amb} = 0 \text{ }^\circ\text{C to } 70 \text{ }^\circ\text{C}$

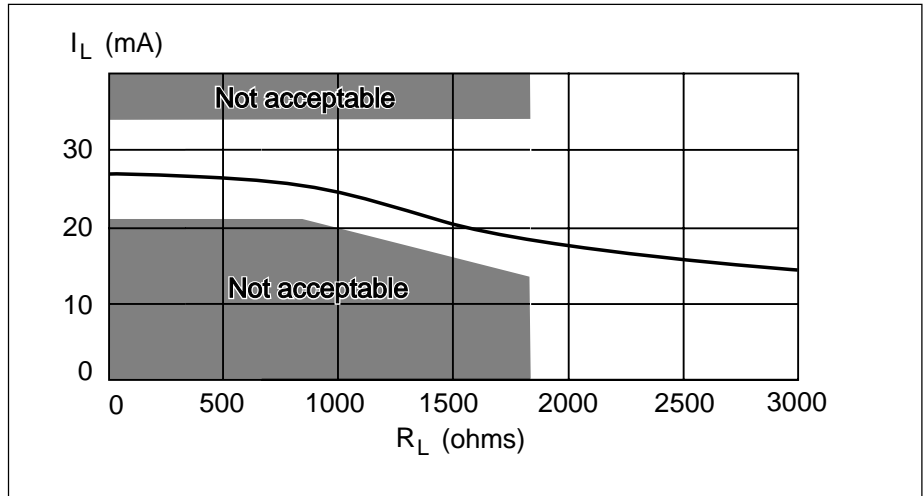

Figure 14. Loop current detector.

On-hook to off-hook loop current threshold,  $I_{LThOff}$ :

$I_{LThOff} = 8.0 \text{ mA for } R_D \rightarrow \infty$   
 For  $I_{LThOff} > 8.0 \text{ mA}$ :

$$R_D = \frac{1}{I_{LThOff} / K_{LThOff} - 1/62500}$$

$K_{LThOff} = 500V \text{ (includes factor K)}$

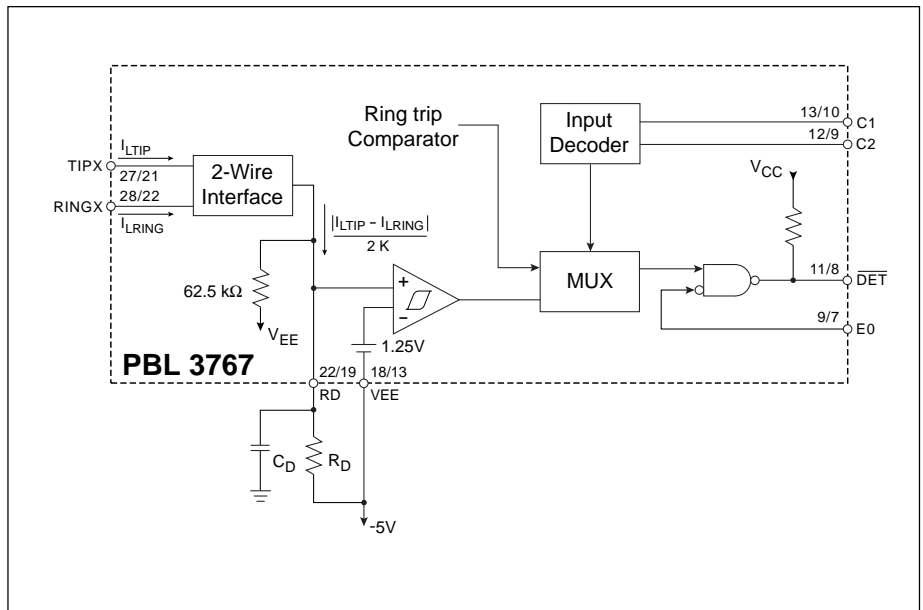

indicating ringtrip condition. Capacitors  $C_1$  and  $C_2$  filter the ringing voltage at the comparator input. With component values according to figure 16, 20 Hz ringing will be attenuated by 20 dB and 30 Hz ringing will be attenuated by 23 dB before reaching the DT input.

**Relay Driver**

The PBL 3767 SLIC incorporates a ring relay driver designed as open emitter with grounded collector (npn) having a current sourcing capability of 50 mA. The relay coil must be connected to a negative

voltage  $\leq |V_{Bat}|$ . An external inductive kick-back clamp diode must be employed to protect the drive transistor.

**Control Inputs**

**Overview**

The PBL 3767 SLIC has two TTL compatible control inputs, C1 and C2. A decoder in the SLIC interprets the control input conditions and sets up the commanded operating state.

**Open Circuit State (C2, C1 = 0, 0)**

In the Open Circuit State the TIPX and RINGX line drive amplifiers as well as other circuit blocks are powered down. This causes the SLIC to present a high impedance to the line. Power dissipation is at a minimum. No detectors are active.

**Ringing State (C2, C1 = 0, 1)**

The ring relay driver, RINGRLY, is activated and the ring trip comparator is connected to the detector output, DET. The TIPX and RINGX terminals are in the high impedance state and signal transmission is inhibited.

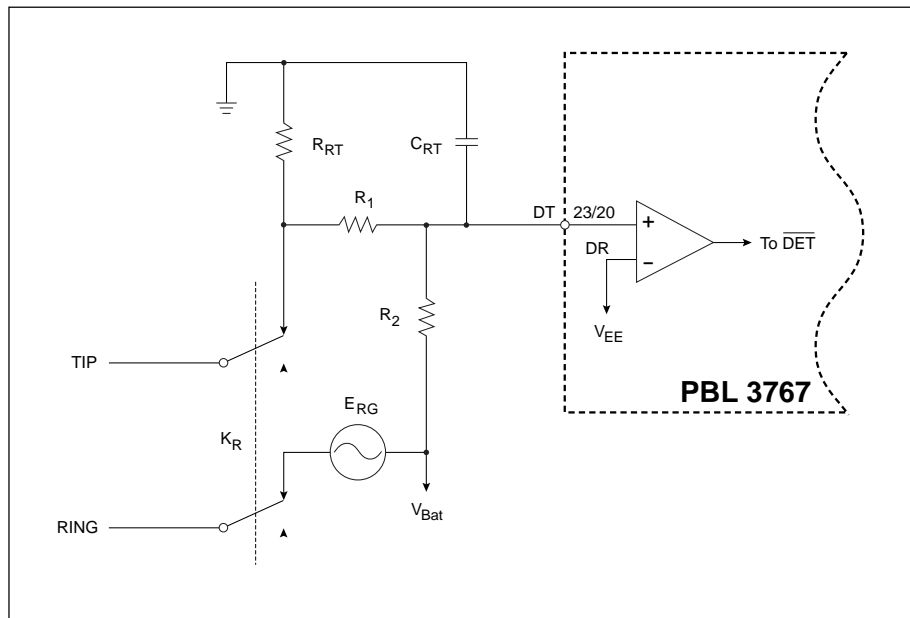

Figure 15. Example ring trip network, unbalanced ringing.

**Note:** Ericsson Components unbalanced ring trip network PBA 3310 contains a two-pole filter.

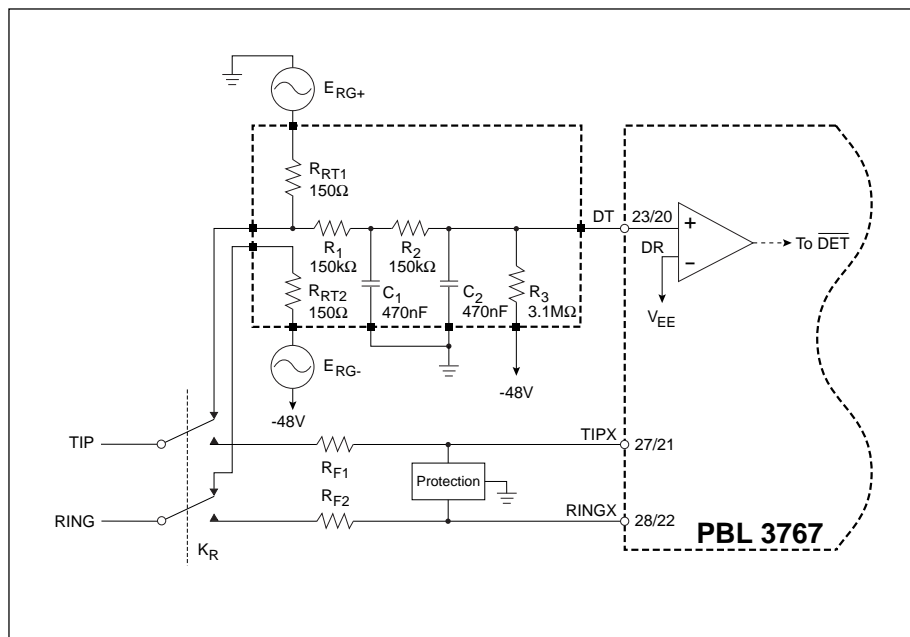

Figure 16. Example ring trip network, balanced ringing.



**Active State (C2, C1 = 1, 0)**

TIPX is the terminal closest to ground potential and sources loop current, while RINGX is the more negative terminal and sinks loop current. Vf signal transmission is normal. The loop current detector is activated and connected to the  $\overline{\text{DET}}$  output.

**Stand-By State (C2, C1 = 1, 1)**

In the stand-by state the line drive amplifiers are disconnected. The loop feed is converted to resistive form according to

$$I_L \approx \frac{|V_{\text{Bat}}| - 3 \text{ V}}{R_L + 1800 \ \Omega}$$

where

$I_L$  = loop current (A)

$V_{\text{Bat}}$  = battery supply voltage (V)

$R_L$  = loop resistance (ohm)

The short circuit loop current ( $I_{\text{LSh}}$ ) for  $V_{\text{Bat}} = -48\text{V}$  is then limited to  $I_{\text{LSh}} \approx 25.0 \text{ mA}$ .

The loop current detector is activated in the stand-by state and is gated to the  $\overline{\text{DET}}$  output.

Table 1 summarizes the above description of the control inputs.

**Enable Input (E0)**

TTL compatible enable input E0 controls the function of the  $\overline{\text{DET}}$  output.

E0, when set to logic level low, enables the  $\overline{\text{DET}}$  output, which is a collector output with internal pull-up resistor (approx. 15 kohms) to  $V_{\text{CC}}$ . A  $\overline{\text{DET}}$  output at logic level low indicates triggered detector condition (loop current above threshold current or telephone off-hook during ringing). A  $\overline{\text{DET}}$  output at logic level high indicates a non triggered detector condition.

E0, when set to logic level high disables the  $\overline{\text{DET}}$  output; i.e. it appears as a resistor connected to  $V_{\text{CC}}$ .

Table 2 summarizes the above description of the enable input.

**Overvoltage Protection**

The PBL 3767 SLIC must be protected against overvoltages and power crosses. Refer to Maximum Ratings, TIPX and RINGX terminals for maximum allowable continuous and transient voltages, that may be applied to the SLIC. The circuit shown in figure 11 utilizes series resistors ( $R_F$ ,  $R_P$ ) together with a programmable overvoltage protector (e.g. Texas Instrument TISP PBL1), serving as a secondary

protection. The protection network in figure 11 is designed to meet requirements in CCITT K20, Table 1.

The TISP PBL1 is a dual forward-conducting buffered p-gate overvoltage protector. The protector gate references the protection (clamping) voltage to negative supply voltage (i.e. the battery voltage,  $V_{\text{Bat}}$ ). As the protection voltage will track the negative supply voltage the overvoltage stress on the SLIC is minimized.

Positive overvoltages are clamped to ground by an internal diode. Negative overvoltages are initially clamped close to the SLIC negative supply rail voltage. If sufficient current is available from the overvoltage, then the protector will crawlbar into a low voltage on-state condition, clamping the over-voltage close to ground.

A gate decoupling capacitor,  $C_{\text{TISP}}$  is needed to carry enough charge to supply a high enough current to quickly turn on the thyristor in the protector. Without the capacitor even the low inductance in the track to the  $V_{\text{Bat}}$  supply will limit the current and delay the activation of the thyristor clamp.

The fuse resistors  $R_F$ , serve the dual purposes of being non-destructive energy dissipators, when transients are clamped and of being fuses, when the line is exposed to a power cross. Ericsson Components AB offers a series of thick

*Table 1. PBL 3767 operating states.*

| State number | C2 | C1 | SLIC operating state | Active detector     | $\overline{\text{DET}}$ Output Note 1. |
|--------------|----|----|----------------------|---------------------|--|
| 1            | 0  | 0  | Open circuit         | No active detector  | Logic level high                       |
| 2            | 0  | 1  | Ringing              | Ring trip detector  | Ring trip status                       |
| 3            | 1  | 0  | Active               | Loop curr. detector | Loop current status                    |
| 4            | 1  | 1  | Stand-by             | Loop curr. detector | Loop current status                    |

**Notes**

1. E0 = 0, i.e. the  $\overline{\text{DET}}$  output is enabled. A logic low level at the  $\overline{\text{DET}}$  output indicates a triggered detector.

*Table 2. Enable input E0.*

| Enable state | E0 | $\overline{\text{DET}}$ output status | Active detector                            |
|--------------|----|---------------------------------------|--|
| 1            | 0  | Active                                | Loop current or ring trip detector Note 1. |
| 2            | 1  | High impedance Note 2.                | None                                       |

**Notes**

1. Detector selected according to Table 1.
2. In the high impedance state the  $\overline{\text{DET}}$  output appears as a 15 kohms resistor to  $V_{\text{CC}}$ .

film resistors networks (e.g. PBR 51-series and PBR 53-series) designed for this application.

Also devised with a build in resettable fuse function is offered (e.g. PBR 52-series) including positive temperature coefficient (PTC) resistors, working as resettable fuses, in series with thick film resistors. Note that it is important to always use PTC's in series with resistors not sensitive to temperature, as the PTC will act as a capacitance for fast transients and therefore the ability to protect the SLIC will be reduced.

If there is a risk for overvoltages on the  $V_{\text{Bat}}$  terminal on the SLIC, then this terminal should also be protected.

**Overtemperature Protection**

A ring lead to ground short circuit fault condition, as well as other improper operating modes, may cause excessive SLIC power dissipation. If junction temperature increases beyond 160 °C, the temperature guard will trigger, causing the SLIC to be set to a high impedance state. In this high impedance state power dissipation is reduced and the junction temperature will return to a safe value. Once below 140 °C junction temperature the SLIC is returned back to its normal operating mode and will remain in that state assuming the fault condition has been removed.

## Power-up Sequence

The voltage at pin VBAT sets the substrate voltage, which must at all times be kept more negative than the voltage at any other terminal. This is to maintain correct junction isolation between devices on the chip. To prevent possible latch-up, the correct power-up sequence is to connect ground and  $V_{Bat}$ , then other supply voltages and signal leads. A diode with a 2 A current rating, connected with

its cathode to  $V_{EE}$  and anode to  $V_{Bat}$ , ensures the presence of the most negative supply voltage at the VBAT terminals, should the  $V_{Bat}$  supply voltage be absent.

The  $V_{Bat}$  voltage should not be applied at a faster rate than  $\partial V_{Bat}/\partial t = 4 \text{ V}/\mu\text{sec}$  or with a time constant formed by a 5.1 ohm resistor in series with the VBAT pin and a 0.47 microfarad capacitor from the VBAT pin to ground. One resistor may be shared by several SLICs.

## Printed Circuit Board Lay-out

Care in PCB layout is essential for proper function. The components connecting to the RSN input should be placed in close proximity to that pin, such that no interference is injected into the RSN terminal. A ground plane surrounding the RSN pin is advisable. The  $C_{HP}$  capacitor should be placed close to terminals HPT and HPR to avoid unwanted disturbances.

## Ordering information

| Package            | Temp. Range   | Part No.     |
|--------------------|---------------|--------------|
| Plastic DIP 22 pin | 0 °C to 70 °C | PBL 3767N    |
| Plastic DIP 22 pin | 0 °C to 70 °C | PBL 3767/6N  |
| PLCC 28 pin        | 0 °C to 70 °C | PBL 3767QN   |
| PLCC 28 pin        | 0 °C to 70 °C | PBL 3767/6QN |

Information given in this data sheet is believed to be accurate and reliable. However no responsibility is assumed for the consequences of its use nor for any infringement of patents or other rights of third parties which may result from its use. No license is granted by implication or otherwise under any patent or patent rights of Ericsson Components AB. These products are sold only according to Ericsson Components AB' general conditions of sale, unless otherwise confirmed in writing.

Specifications subject to change without notice.

1522-PBL 3767 Uen Rev. B

© Ericsson Components AB

September 1997

This product is an original Ericsson product protected by US, European and other patents.

**ERICSSON** 

**Ericsson Components AB**

S-164 81 Kista-Stockholm, Sweden

Telephone: (08) 757 50 00