

LINEAR INTEGRATED CIRCUITS

DESCRIPTION

The PA239 is a dual low noise preamplifier featuring two identically-matched 68dB gain amplifiers fed from an internal zener regulated power supply. Operation requires only a single power supply and a minimum number of external frequency shaping components.

FEATURES

- MATCHED OPEN LOOP VOLTAGE GAIN
- LOW AUDIO NOISE
- SINGLE POWER SUPPLY
- WIDE POWER SUPPLY RANGE
- BUILT-IN POWER SUPPLY FILTER
- HIGH INPUT IMPEDANCE
- EMITTER FOLLOWER OUTPUT
- LOW DISTORTION
- SELF BIASING
- MINIMUM NUMBER OF EXTERNAL COMPONENTS
- OUTPUT CIRCUIT IS SHORT CIRCUIT PROTECTED
- HIGH CHANNEL SEPARATION
- VARIETY OF FEEDBACK OPTIONS
- NO CIRCUIT DAMAGE IF PLUGGED IN BACKWARDS
- 7.5V REGULATOR BIAS SOURCE

ABSOLUTE MAXIMUM RATINGS

Supply Voltage	16V
Temperature	
Storage	-55°C to +150°C
Operating	-30°C to +85°C

SCHEMATIC DIAGRAM

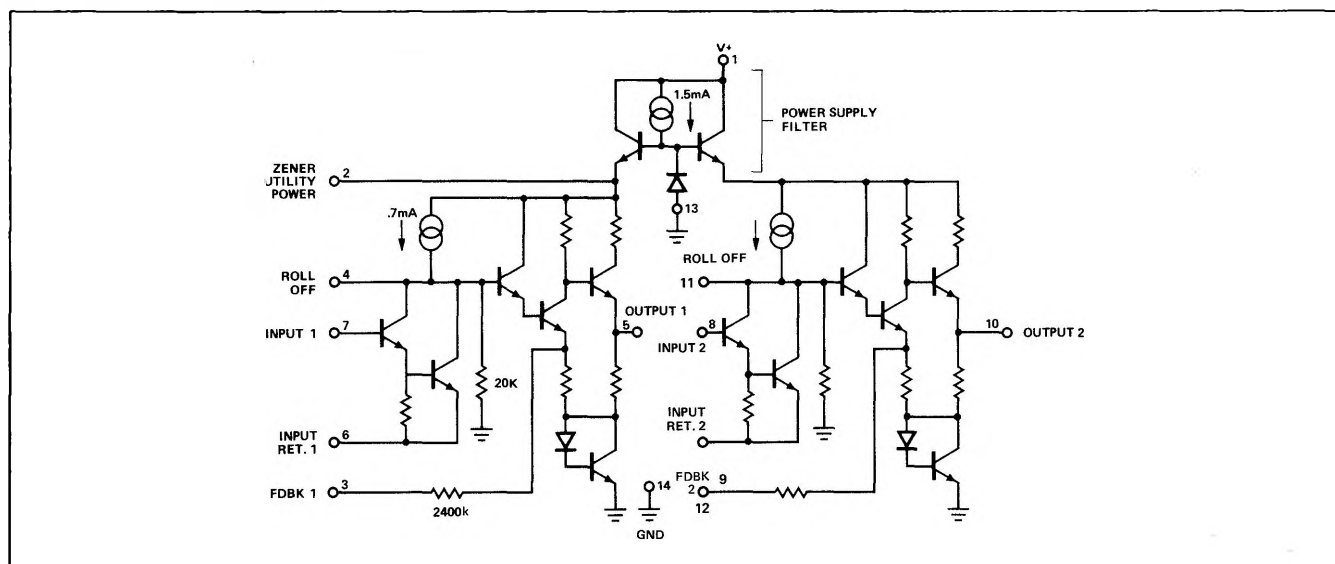

PIN CONFIGURATION

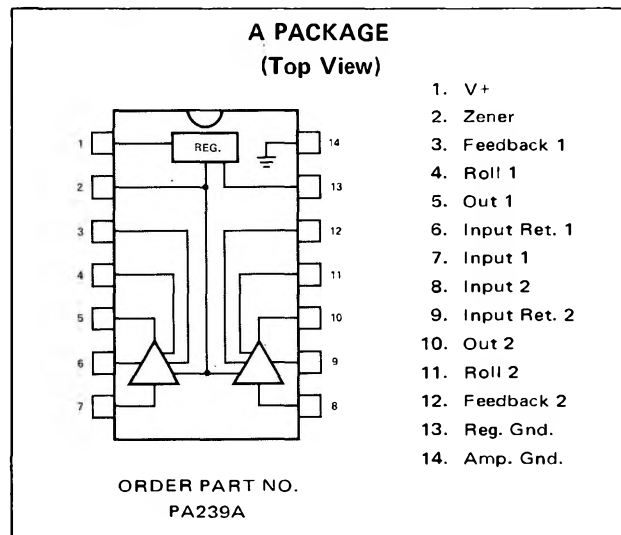

APPLICATIONS

- STEREO TAPE PLAYERS/RECORDERS
- DICTATING EQUIPMENT
- MOVIE PROJECTORS
- PHONOGRAPHS
- TV REMOTE CONTROL RECEIVER
- MICROPHONE AMPLIFIERS
- STEREO RADIO RECEIVER SYSTEMS
- VIDEO PREAMPLIFICATION
- NARROW BAND AMPLIFICATION
- DRIVER-PREAMP FOR LOSSY NETWORKS
- SUPER GAIN CASCADED AMPLIFIERS

ELECTRICAL CHARACTERISTICS (25°C) (V_{CC} = 12V)

PARAMETERS	MIN	TYP	MAX	UNITS
Supply Current (V _{CC} = 12V)		16	22	mA
Voltage Gain	65	68	71	dB
Gain Balance		0.3	2	dB
Channel Separation (f = 1 kHz), Figure 1	45	90		dB
Input Resistance	100K	250K		Ω
Signal Output		1.5		V _{rms}
Output Resistance		100		Ω
Power Supply Rejection (f = 1 kHz), Figure 2	45	55		dB
Total Harmonic Distortion Without Feedback (0.5V rms into 3kΩ Load, 1 kHz)		0.5	0.9	%
Input dc Bias Current		0.8	3	μA
Gain to Feedback Terminal 3, 12		45		dB
Impedance at Feedback Terminal		2400		Ω
Amplifier Noise Figure (100Hz to 10 kHz, 5kΩ R _s)		1.8		dB
Equivalent Input Noise (100Hz to 10 kHz, 680Ω R _s)		0.7	1.2	μV

TEST CIRCUITS

CHANNEL SEPARATION

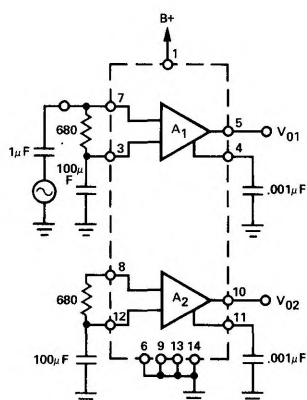

Figure 1

POWER SUPPLY REJECTION

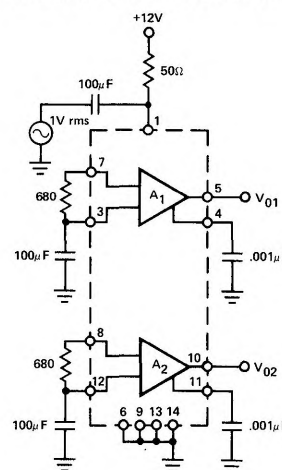

Figure 2

NOISE

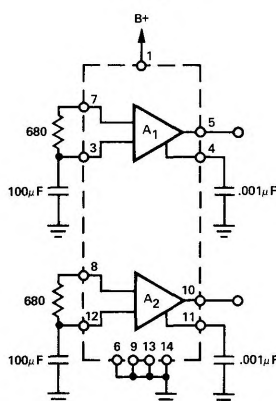

Figure 3