



SANYO Semiconductors

# DATA SHEET

An ON Semiconductor Company

## LV8772 — Bi-CMOS LSI PWM Constant-Current Control Stepping Motor Driver

### Overview

The LV8772 is a stepping motor driver, which is capable of micro-step drive and supports 4W 1-2 phase excitation. It is stepping motors used in office equipment and amusement applications.

### Features

- Low on resistance (upper side : 0.3Ω ; lower side : 0.25Ω ; total of upper and lower : 0.55Ω ; Ta = 25°C, IO = 2.5A)
- Excitation mode can be set to 2-phase, 1-2 phase, W1-2 phase , or 4W1-2 phase
- BiCDMOS process IC
- Motor current selectable in four steps
- Unusual condition warning output pins
- Excitation step proceeds only by step signal input
- Output short-circuit protection circuit incorporated
- No control power supply required

### Specifications

**Absolute Maximum Ratings** at Ta = 25°C

Parameter	Symbol	Conditions	Ratings	Unit
Supply voltage	VM max		36	V
Output peak current	IO peak	tw ≤ 10ms, duty 20%	3.0	A
Output current	IO max		2.5	A
Logic input voltage	VIN		-0.3 to +6	V
MONI/EMO input voltage	Vmoni/Vemo		-0.3 to +6	V
Allowable power dissipation	Pd max1	1 unit	3.0	W
	Pd max2	*	5.4	W
Operating temperature	Topr		-20 to +85	°C
Storage temperature	Tstg		-55 to +150	°C

\* Specified circuit board : 90.0mm×90.0mm×1.6mm, glass epoxy 2-layer board, with backside mounting.

Caution 1) Absolute maximum ratings represent the value which cannot be exceeded for any length of time.

Caution 2) Even when the device is used within the range of absolute maximum ratings, as a result of continuous usage under high temperature, high current, high voltage, or drastic temperature change, the reliability of the IC may be degraded. Please contact us for the further details.

■ Any and all SANYO Semiconductor Co.,Ltd. products described or contained herein are, with regard to "standard application", intended for the use as general electronics equipment. The products mentioned herein shall not be intended for use for any "special application" (medical equipment whose purpose is to sustain life, aerospace instrument, nuclear control device, burning appliances, transportation machine, traffic signal system, safety equipment etc.) that shall require extremely high level of reliability and can directly threaten human lives in case of failure or malfunction of the product or may cause harm to human bodies, nor shall they grant any guarantee thereof. If you should intend to use our products for new introduction or other application different from current conditions on the usage of automotive device, communication device, office equipment, industrial equipment etc. , please consult with us about usage condition (temperature, operation time etc.) prior to the intended use. If there is no consultation or inquiry before the intended use, our customer shall be solely responsible for the use.

■ Specifications of any and all SANYO Semiconductor Co.,Ltd. products described or contained herein stipulate the performance, characteristics, and functions of the described products in the independent state, and are not guarantees of the performance, characteristics, and functions of the described products as mounted in the customer's products or equipment. To verify symptoms and states that cannot be evaluated in an independent device, the customer should always evaluate and test devices mounted in the customer's products or equipment.

**SANYO Semiconductor Co., Ltd.**

<http://semicon.sanyo.com/en/network>

# LV8772

## Allowable Operating Ratings at Ta = 25°C

Parameter	Symbol	Conditions	Ratings	Unit
Supply voltage range	VM		9 to 32	V
Logic input voltage	V <sub>IN</sub>		0 to 5.5	V
VREF input voltage range	VREF		0 to 3	V

## Electrical Characteristics at Ta = 25°C, VM = 24V, VREF = 1.5V

Parameter	Symbol	Conditions	Ratings			Unit	
			min	typ	max		
Standby mode current drain	IMst	ST = "L"		100	400	μA	
Current drain	IM	ST = "H", with no load		3.2	5	mA	
VREG5 output voltage	Vreg5	I <sub>O</sub> = -1mA	4.5	5	5.5	V	
Thermal shutdown temperature	TSD	Design guarantee	150	180	200	°C	
Thermal hysteresis width	ΔTSD	Design guarantee		40		°C	
<b>Motor driver</b>							
Output on resistance	Ronu	I <sub>O</sub> = 2.5A, Upper-side on resistance		0.3	0.4	Ω	
	Rond	I <sub>O</sub> = 2.5A, Lower-side on resistance		0.25	0.33	Ω	
Output leakage current	I <sub>Oleak</sub>				50	μA	
Diode forward voltage	VD	ID = -2.5A		1.2	1.4	V	
Logic pin input current	I <sub>INL</sub>	V <sub>IN</sub> = 0.8V	4	8	12	μA	
	I <sub>INH</sub>	V <sub>IN</sub> = 5V	30	50	70	μA	
Logic high-level input voltage	V <sub>INH</sub>		2.0			V	
Logic low-level input voltage	V <sub>INL</sub>				0.8	V	
Current setting comparator threshold voltage (current step switching)	4W1-2-phase drive	Vtdac0_4W	Step 0 (When initialized : channel 1 comparator level)	0.291	0.3	0.309	V
		Vtdac1_4W	Step 1 (Initial state+1)	0.291	0.3	0.309	V
		Vtdac2_4W	Step 2 (Initial state+2)	0.285	0.294	0.303	V
		Vtdac3_4W	Step 3 (Initial state+3)	0.279	0.288	0.297	V
		Vtdac4_4W	Step 4 (Initial state+4)	0.267	0.276	0.285	V
		Vtdac5_4W	Step 5 (Initial state+5)	0.255	0.264	0.273	V
		Vtdac6_4W	Step 6 (Initial state+6)	0.240	0.249	0.258	V
		Vtdac7_4W	Step 7 (Initial state+7)	0.222	0.231	0.240	V
		Vtdac8_4W	Step 8 (Initial state+8)	0.201	0.210	0.219	V
		Vtdac9_4W	Step 9 (Initial state+9)	0.180	0.189	0.198	V
		Vtdac10_4W	Step 10 (Initial state+10)	0.157	0.165	0.173	V
		Vtdac11_4W	Step 11 (Initial state+11)	0.134	0.141	0.148	V
		Vtdac12_4W	Step 12 (Initial state+12)	0.107	0.114	0.121	V
		Vtdac13_4W	Step 13 (Initial state+13)	0.080	0.087	0.094	V
		Vtdac14_4W	Step 14 (Initial state+14)	0.053	0.060	0.067	V
	Vtdac15_4W	Step 15 (Initial state+15)	0.023	0.030	0.037	V	
	W1-2-phase drive	Vtdac0_W	Step 0 (When initialized : channel 1 comparator level)	0.291	0.3	0.309	V
		Vtdac4_W	Step 4 (Initial state+1)	0.267	0.276	0.285	V
		Vtdac8_W	Step 8 (Initial state+2)	0.201	0.21	0.219	V
		Vtdac12_W	Step 12 (Initial state+3)	0.107	0.114	0.121	V
1-2 phase drive	Vtdac0_H	Step 0 (When initialized : channel 1 comparator level)	0.291	0.3	0.309	V	
	Vtdac8_H	Step 8 (Initial state+1)	0.201	0.21	0.219	V	
2 phase drive	Vtdac8_F	Step 8' (When initialized : channel 1 comparator level)	0.291	0.3	0.309	V	
Current setting comparator threshold voltage (current attenuation rate switching)	Vtatt00	ATT1 = L, ATT2 = L	0.291	0.3	0.309	V	
	Vtatt01	ATT1 = H, ATT2 = L	0.232	0.24	0.248	V	
	Vtatt10	ATT1 = L, ATT2 = H	0.143	0.15	0.157	V	
	Vtatt11	ATT1 = H, ATT2 = H	0.053	0.06	0.067	V	
Chopping frequency	Fchop	Cchop = 180pF	45	55	65	kHz	
CHOP pin charge/discharge current	Ichop		7	10	13	μA	

Continued on next page.

# LV8772

Continued from preceding page.

Parameter	Symbol	Conditions	Ratings			Unit
			min	typ	max	
Chopping oscillation circuit threshold voltage	Vtup		0.8	1	1.2	V
	Vtdown		0.4	0.5	0.6	V
VREF pin input current	Iref	VREF = 1.5V	-0.5			μA
MONI pin saturation voltage	Vsatmon	Imoni = 1mA			400	mV
<b>Charge pump</b>						
VG output voltage	VG		28	28.7	29.8	V
Rise time	tONG	VG = 0.1μF, CP1-CP2 = 0.1μF, ST = "H" → VG = VM+4V		200	500	μS
Oscillator frequency	Fosc		90	125	150	kHz
<b>Output short-circuit protection</b>						
EMO pin saturation voltage	Vsatemo	Iemo = 1mA			400	mV

## Package Dimensions

unit : mm (typ)

3147C

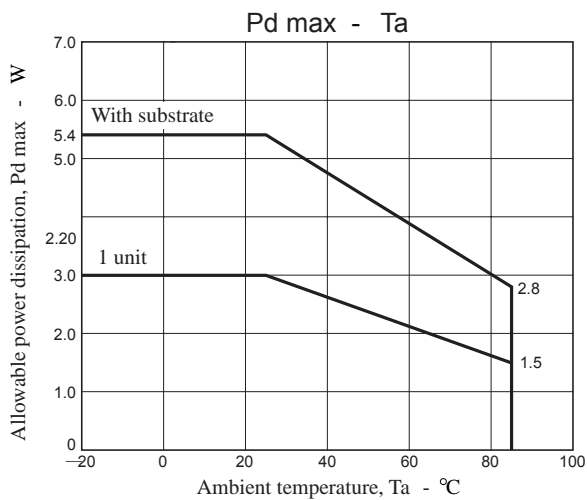
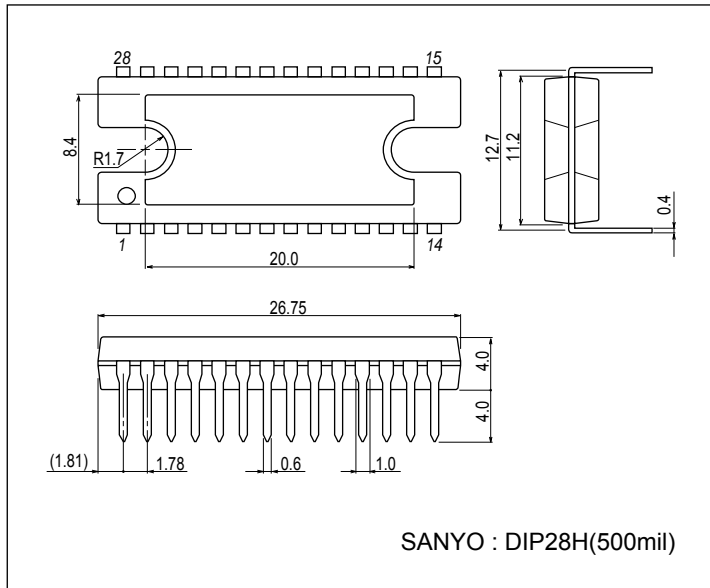

Block Diagram

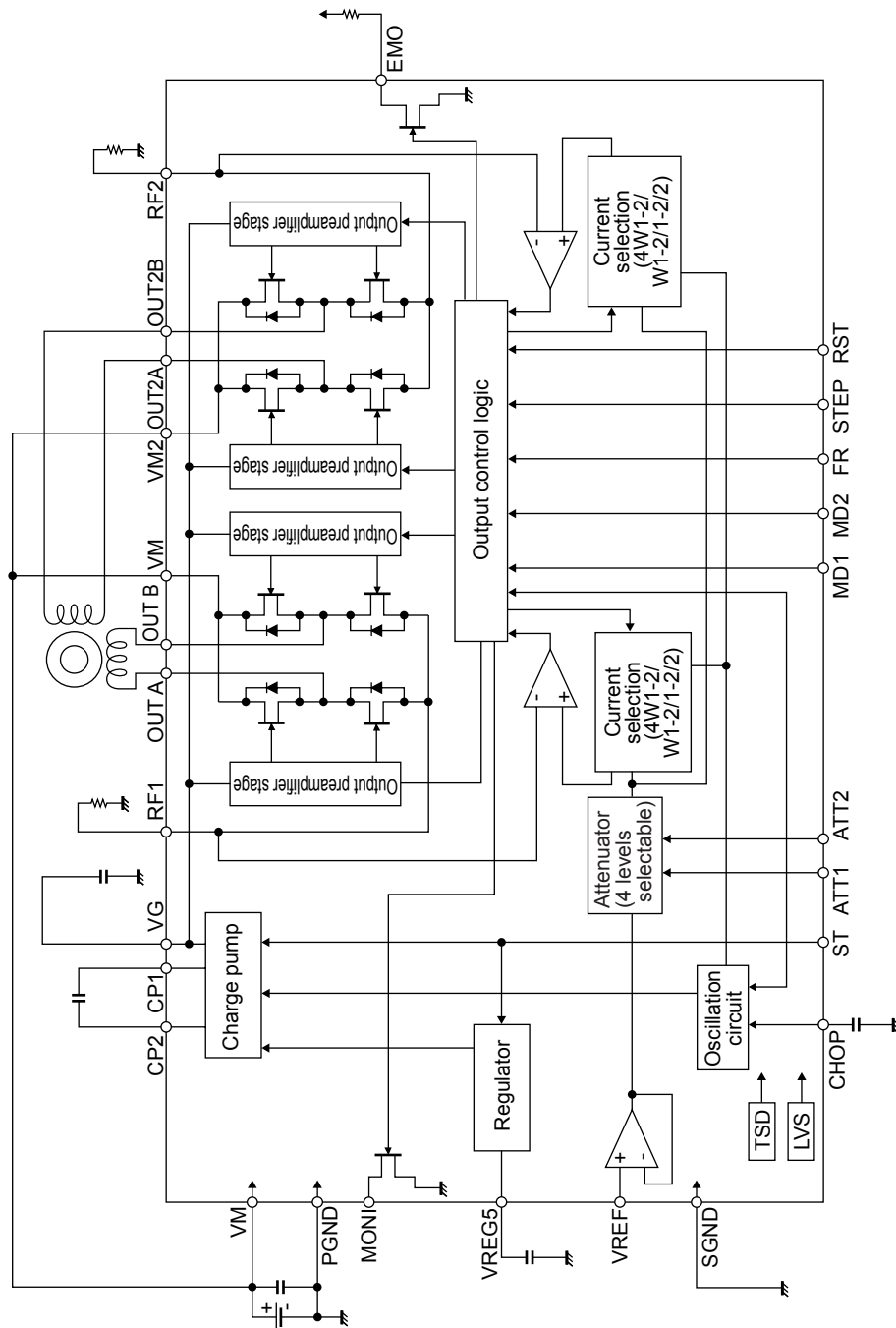

# LV8772

## Pin Assignment

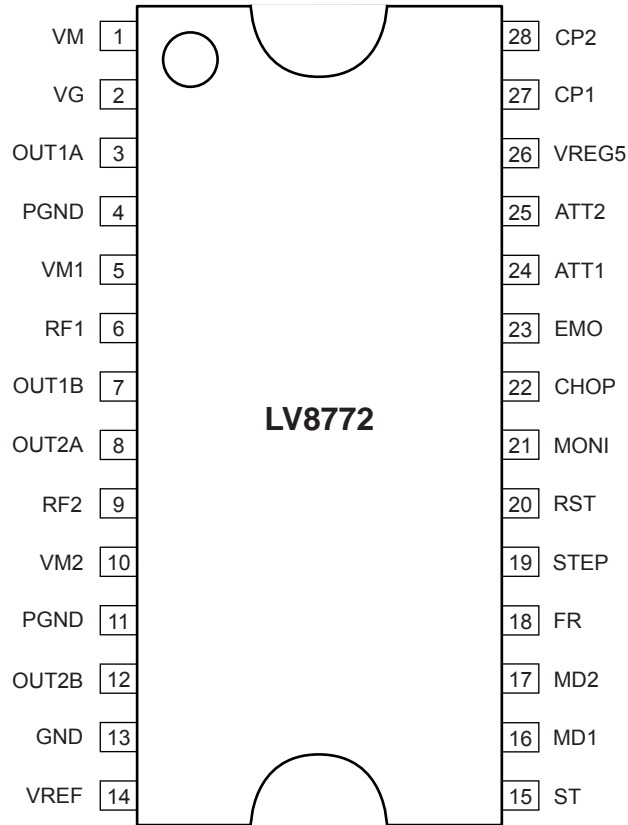

Top view

## Pin Functions

Pin No.	Pin Name	Pin Function	Equivalent Circuit
25 24 20 19 18 17 16	ATT2 ATT1 RST STEP FR MD2 MD1	Motor holding current switching pin. Motor holding current switching pin. RESET input pin STEP signal input pin CW / CCW signal input pin Excitation mode switching pin 2 Excitation mode switching pin 1	
15	ST	Chip enable pin.	

Continued on next page.

# LV8772

Continued from preceding page.

Pin No.	Pin Name	Pin Function	Equivalent Circuit
12 4/11 10 9 8 7 6 5 3	OUT2B PGND VM2 RF2 OUT2A OUT1B RF1 VM1 OUT1A	Channel 2 OUTB output pin. Power system ground. Channel 2 motor power supply connection pin. Channel 2 current-sense resistor connection pin. Channel 2 OUTA output pin. Channel 1 OUTB output pin. Channel 1 current-sense resistor connection pin. Channel 1 motor power supply pin. Channel 1 OUTA output pin	
2 1 28 27	VG VM CP2 CP1	Charge pump capacitor connection pin. Motor power supply connection pin. Charge pump capacitor connection pin. Charge pump capacitor connection pin	
14	VREF	Constant current control reference voltage input pin	
26	VREG5	Internal power supply capacitor connection pin	

Continued on next page.

# LV8772

Continued from preceding page.

Pin No.	Pin Name	Pin Function	Equivalent Circuit
23 21	EMO MONI	Output short-circuit state warning output pin. Position detection monitor pin.	
22	CHOP	Chopping frequency setting capacitor connection pin	

**Description of operation**

**Input Pin Function**



(1) Chip enable function

This IC is switched between standby and operating mode by setting the ST pin. In standby mode, the IC is set to power-save mode and all logic is reset. In addition, the internal regulator circuit and charge pump circuit do not operate in standby mode.

ST	Mode	Internal regulator	Charge pump
Low or Open	Standby mode	Standby	Standby
High	Operating mode	Operating	Operating

**Stepping mode drive method**

(1) STEP pin function

Input		Operating mode
ST	STP	
Low	*	Standby mode
High		Excitation step proceeds
High		Excitation step is kept

(2) Excitation mode setting function

MD1	MD2	Excitation mode	Initial position	
			Channel 1	Channel 2
Low	Low	2 phase excitation	100%	-100%
High	Low	1-2 phase excitation	100%	0%
Low	High	W1-2 phase excitation	100%	0%
High	High	4W1-2 phase excitation	100%	0%

This is the initial position of each excitation mode in the initial state after power-on and when the counter is reset.

(3) Position detection monitoring function

The MONI position detection monitoring pin is of an open drian type.

When the excitation position is in the initial position, the MONI output is placed in the ON state.

(Refer to "Examples of current waveforms in each of the excitation modes.")

(4) Setting constant-current control reference current

This IC is designed to automatically exercise PWM constant-current chopping control for the motor current by setting the output current. Based on the voltage input to the VREF pin and the resistance connected between RF and GND, the output current that is subject to the constant-current control is set using the calculation formula below :

$$I_{OUT} = (VREF/5)/RF \text{ resistance}$$

\* The above setting is the output current at 100% of each excitation mode.

The voltage input to the VREF pin can be switched to four-step settings depending on the statuses of the two inputs, ATT1 and ATT2. This is effective for reducing power consumption when motor holding current is supplied.

Attenuation function for VREF input voltage

ATT1	ATT2	Current setting reference voltage attenuation ratio
Low	Low	100%
High	Low	80%
Low	High	50%
High	High	20%

The formula used to calculate the output current when using the function for attenuating the VREF input voltage is given below.

$$I_{OUT} = (VREF/5) \times (\text{attenuation ratio})/RF \text{ resistance}$$



Example : At VREF of 1.5V, a reference voltage setting of 100% [(ATT1, ATT2) = (L, L)] and an RF resistance of 0.22Ω, the output current is set as shown below.

$$I_{OUT} = 1.5V/5 \times 100\%/0.22\Omega = 1.36A$$

If, in this state, (ATT1, ATT2) is set to (H, H), IOUT will be as follows :

$$I_{OUT} = 1.36A \times 20\% = 272mA$$

In this way, the output current is attenuated when the motor holding current is supplied so that power can be conserved.

(5) Blanking period

If, when exercising PWM constant-current chopping control over the motor current, the mode is switched from decay to charge, the recovery current of the parasitic diode may flow to the current sensing resistance, causing noise to be carried on the current sensing resistance pin, and this may result in erroneous detection. To prevent this erroneous detection, a blanking period is provided to prevent the noise occurring during mode switching from being received. During this period, the mode is not switched from charge to decay even if noise is carried on the current sensing resistance pin.

This IC is the blanking time is fixed at approximately 1μs.

(6) Reset function

RST	Operating mode
Low	Normal operation
High	Reset state

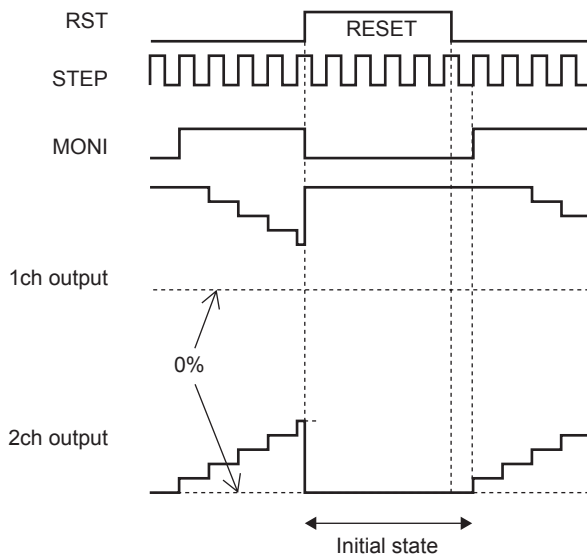

When the RST pin is set to High, the excitation position of the output is forcibly set to the initial state, and the MONI output is placed in the ON state. When RST is then set to Low, the excitation position is advanced by the next STEP input.

(7) Forward/reverse switching function

FR	Operating mode
Low	Clockwise (CW)
High	Counter-clockwise (CCW)

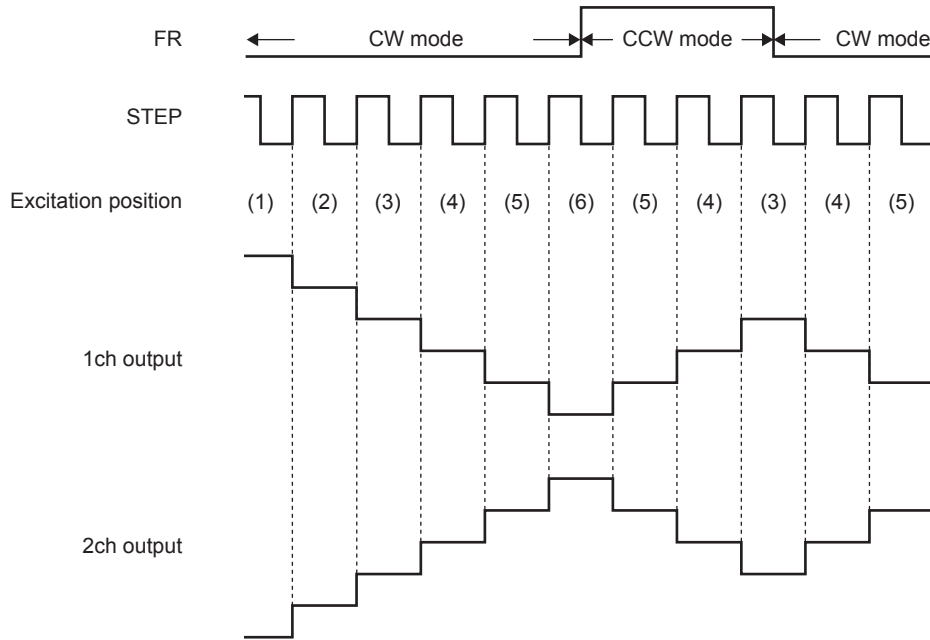

The internal D/A converter proceeds by one bit at the rising edge of the input STEP pulse.  
 In addition, CW and CCW mode are switched by setting the FR pin.  
 In CW mode, the channel 2 current phase is delayed by 90° relative to the channel 1 current.  
 In CCW mode, the channel 2 current phase is advanced by 90° relative to the channel 1 current.

(8) Chopping frequency setting

For constant-current control, this IC performs chopping operations at the frequency determined by the capacitor (Cchop) connected between the CHOP pin and GND.  
 The chopping frequency is set as shown below by the capacitor (Cchop) connected between the CHOP pin and GND.

$$F_{chop} = I_{chop} / (C_{chop} \times V_{tchop} \times 2) \text{ (Hz)}$$

$I_{chop}$  : Capacitor charge/discharge current, typ 10μA

$V_{tchop}$  : Charge/discharge hysteresis voltage ( $V_{tup} - V_{tdown}$ ), typ 0.5V

For instance, when Cchop is 180pF, the chopping frequency will be as follows :

$$F_{chop} = 10\mu A / (180pF \times 0.5V \times 2) = 55kHz$$

# LV8772

(9) Output current vector locus (one step is normalized to 90 degrees)

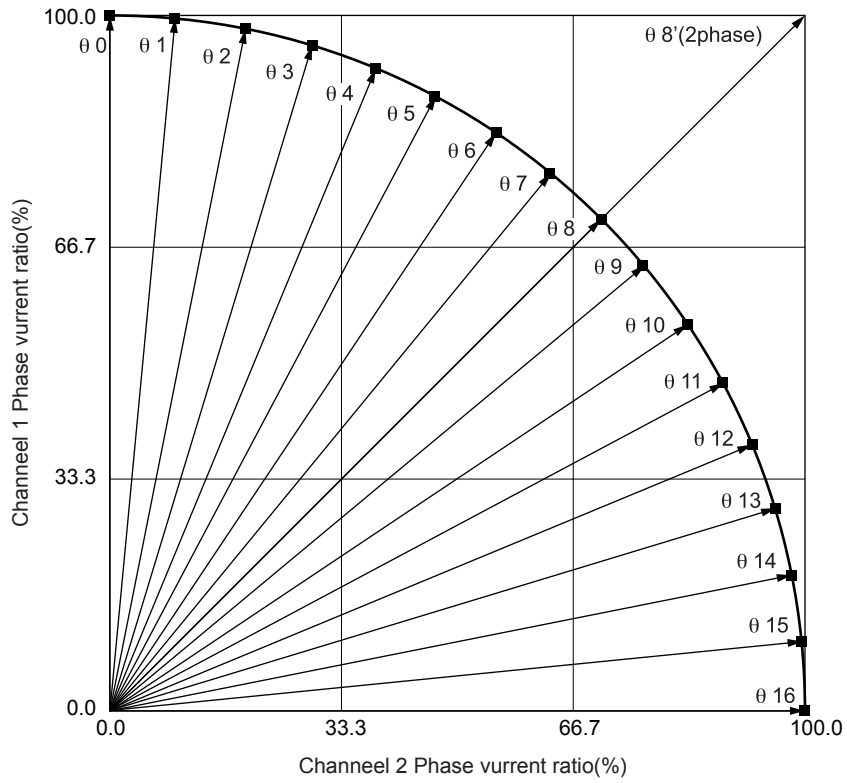

Setting current ration in each excitation mode

STEP	4W1-2 phase (%)		W1-2 phase (%)		1-2 phase (%)		2-phase (%)	
	Channel 1	Channel 2	Channel 1	Channel 2	Channel 1	Channel 2	Channel 1	Channel 2
00	100	0	100	0	100	0		
01	100	10						
02	98	20						
03	96	29						
04	92	38	92	38				
05	88	47						
06	83	55						
07	77	63						
08	70	70	70	70	70	70	100	100
09	63	77						
010	55	83						
011	47	88						
012	38	92	38	92				
013	29	96						
014	20	98						
015	10	100						
016	0	100	0	100	0	100		

(10) Typical current waveform in each excitation mode

2-phase excitation (CW mode)

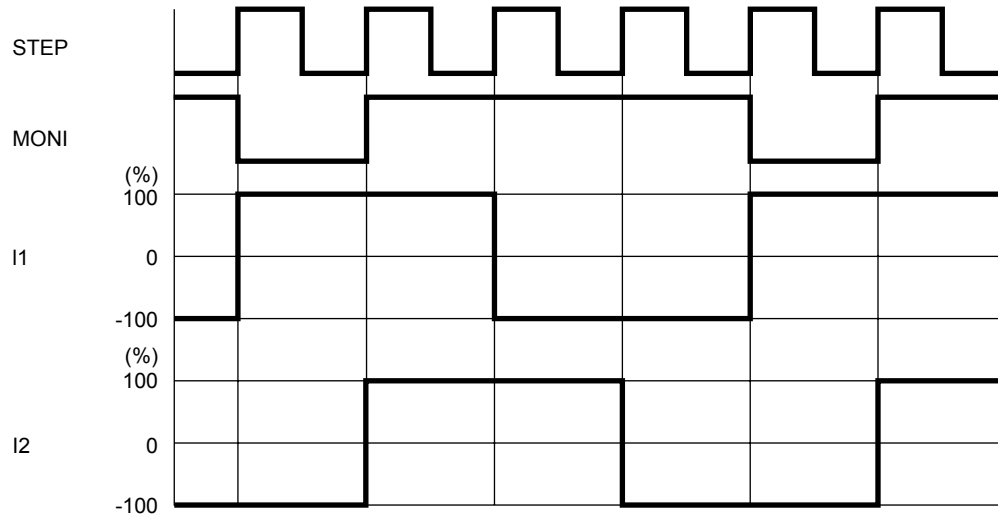

1-2 phase excitation (CW mode)

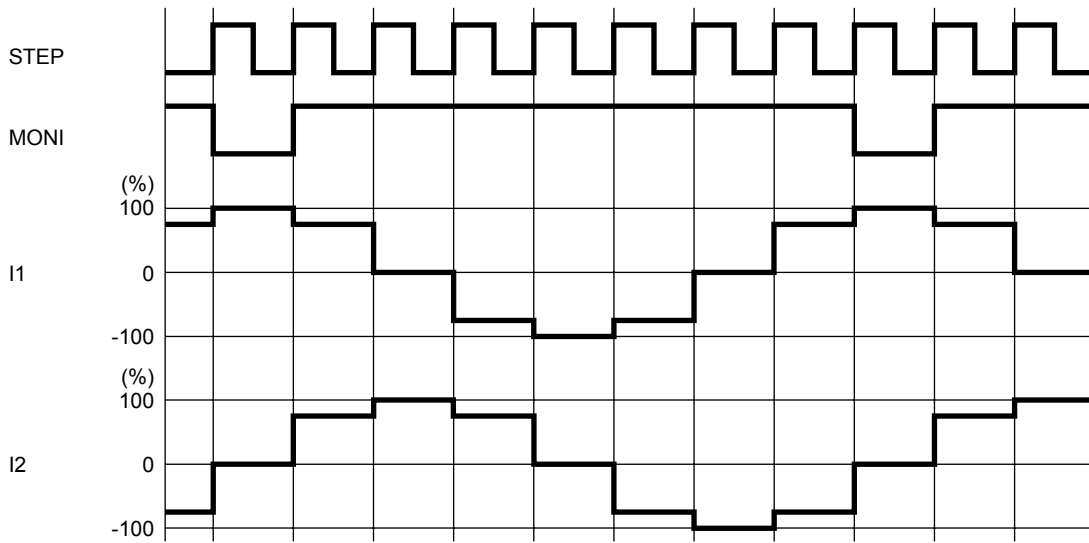

W1-2 phase excitation (CW mode)

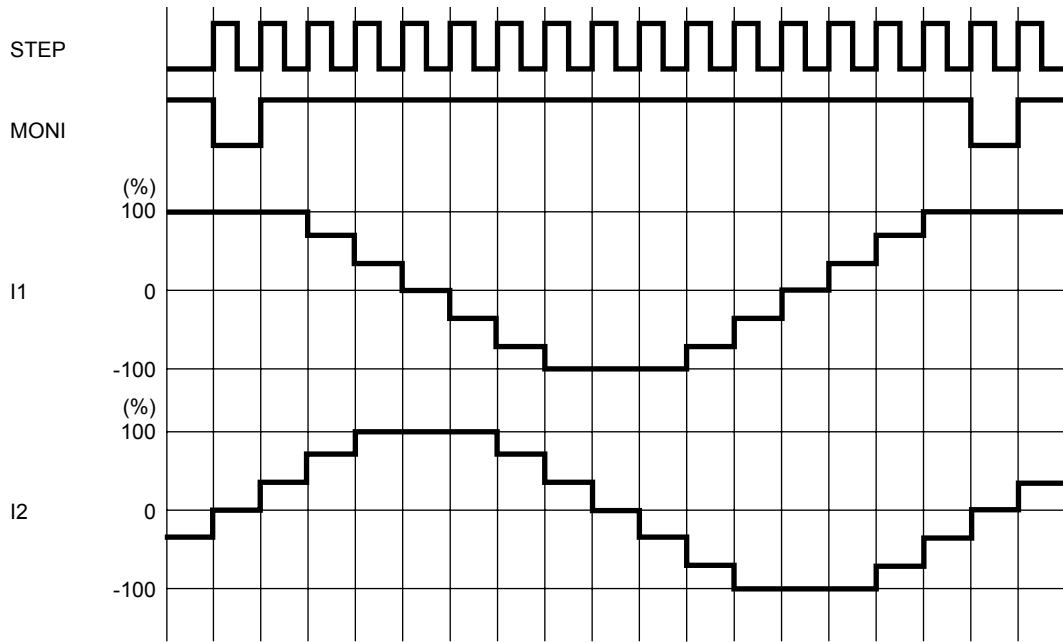

4W1-2 phase excitation (CW mode)

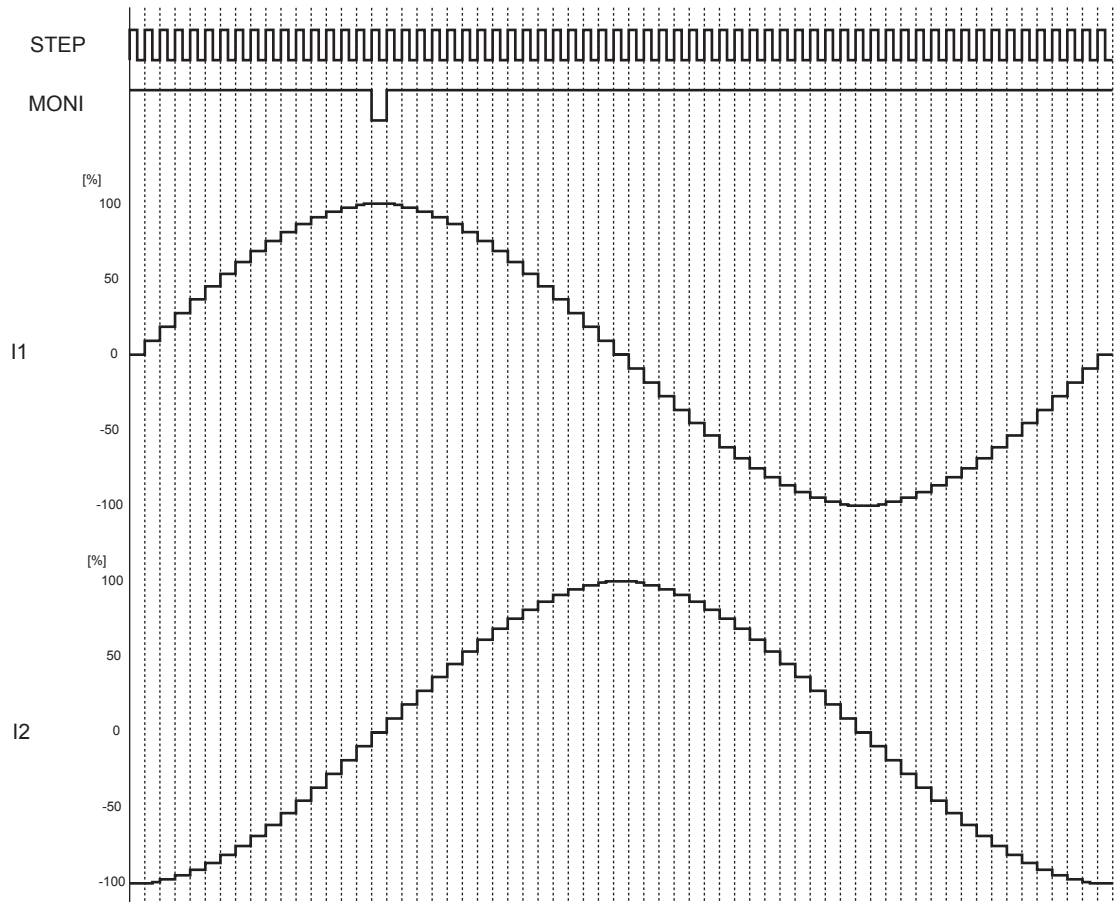

(11) Current control operation specification

(Sine wave increasing direction)

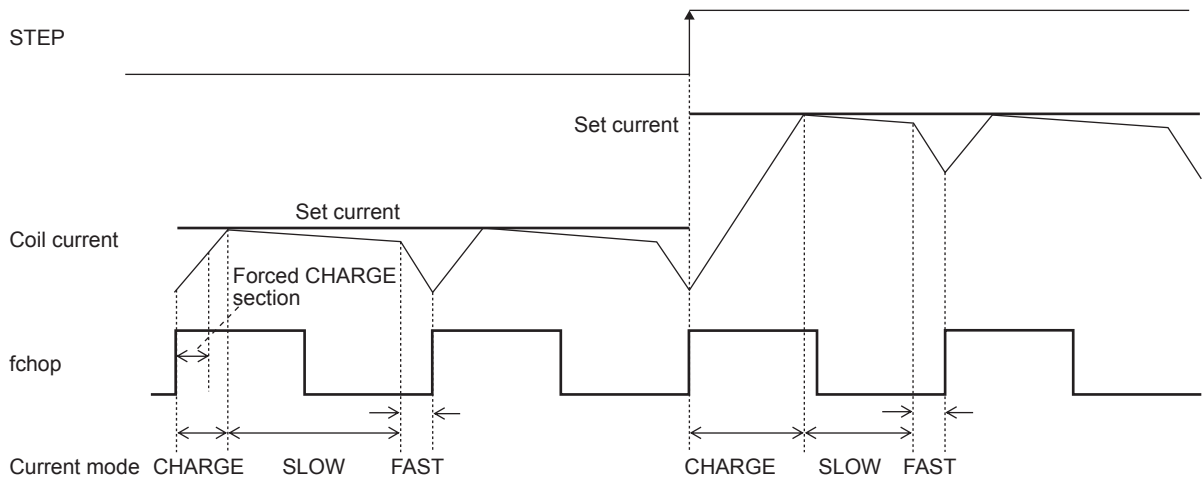

(Sine wave decreasing direction)

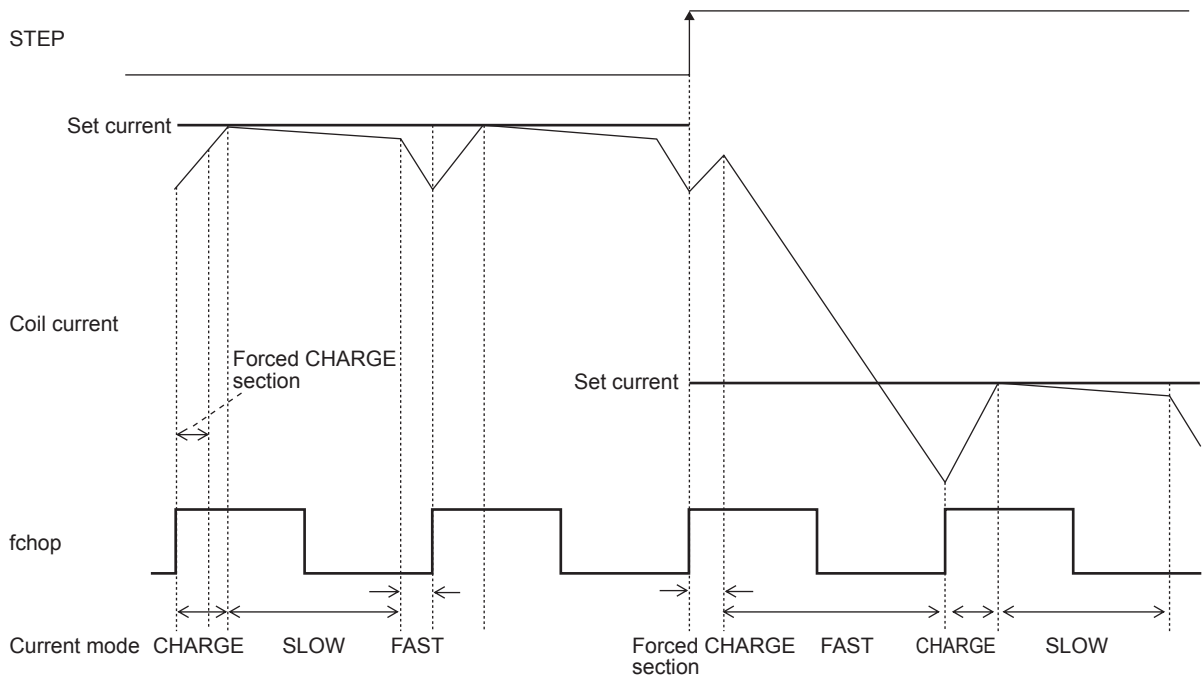

In each current mode, the operation sequence is as described below :

- At rise of chopping frequency, the CHARGE mode begins. (In the time defined as the “blanking time,” the CHARGE mode is forced regardless of the magnitude of the coil current (ICOIL) and set current (IREF).)
- The coil current (ICOIL) and set current (IREF) are compared in this blanking time.

When  $(ICOIL < IREF)$  state exists ;

The CHARGE mode up to  $ICOIL \geq IREF$ , then followed by changeover to the SLOW DECAy mode, and finally by the FAST DECAy mode for approximately  $1\mu s$ .

When  $(ICOIL < IREF)$  state does not exist ;

The FAST DECAy mode begins. The coil current is attenuated in the FAST DECAy mode till one cycle of chopping is over.

Above operations are repeated. Normally, the SLOW (+FAST) DECAy mode continues in the sine wave increasing direction, then entering the FAST DECAy mode till the current is attenuated to the set level and followed by the SLOW DECAy mode.

**Output short-circuit protection function**

This IC incorporates an output short-circuit protection circuit that, when the output has been shorted by an event such as shorting to power or shorting to ground, sets the output to the standby mode and turns on the warning output in order to prevent the IC from being damaged.

This function sets the output to the standby mode for both channels by detecting the short-circuiting in one of the channels.

**(1) Output short-circuit protection method**

The output short-circuit protection method of LV8772 is a latch method to turn off the output when the output current exceeds the detection current, and to maintain the state.

The detection of the output short-circuited state by the IC causes the output short-circuit protection circuit to be activated.

All the outputs of correspondence ch side where the short-circuit was first detected are switched to the standby mode when the short-circuit is the consecutive between internal timers (approximately 4μs), and the state is maintained.

This state is released by setting ST to low.

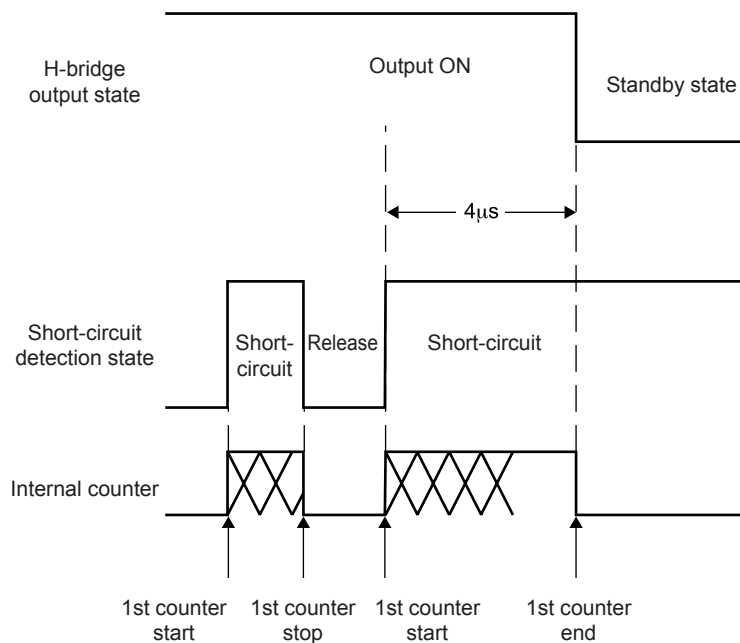

**(2) Unusual condition warning output pins (EMO)**

The LV8772 is provided with the EMO pin which notifies the CPU of an unusual condition if the protection circuit operates by detecting an unusual condition of the IC. This pin is of the open-drain output type and when an unusual condition is detected, the EMO output is placed in the ON (EMO = Low) state.

Furthermore, the EMO pin is placed in the ON state when one of the following conditions occurs.

1. Shorting-to-power, shorting-to-ground, or shorting-to-load occurs at the output pin and the output short-circuit protection circuit is activated.
2. The IC junction temperature rises and the thermal protection circuit is activated.

## Charge Pump Circuit

When the ST pin is set High, the charge pump circuit operates and the VG pin voltage is boosted from the VM voltage to the VM + VREG5 voltage. If the VG pin voltage is not boosted sufficiently, the output cannot be controlled, so be sure to provide a wait time of tONG or more after setting the ST pin High before starting to drive the motor.

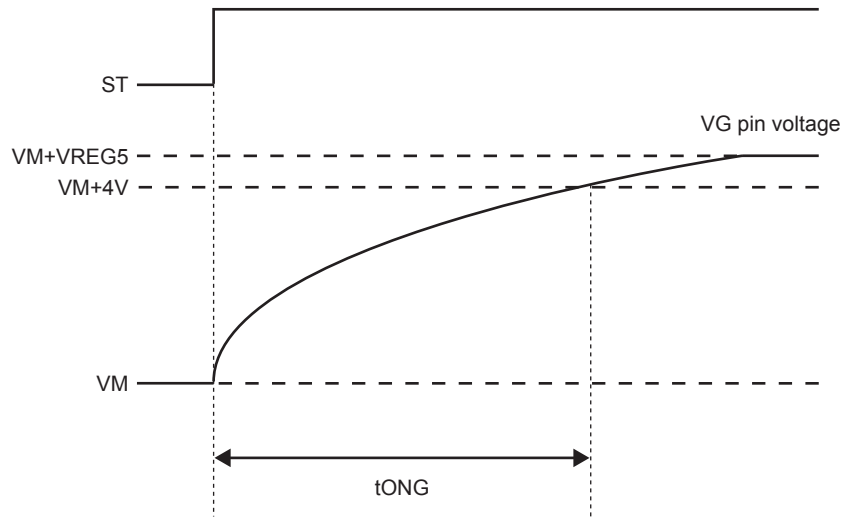

VG Pin Voltage Schematic View



**Application Circuit Example**

- Stepping motor driver circuit

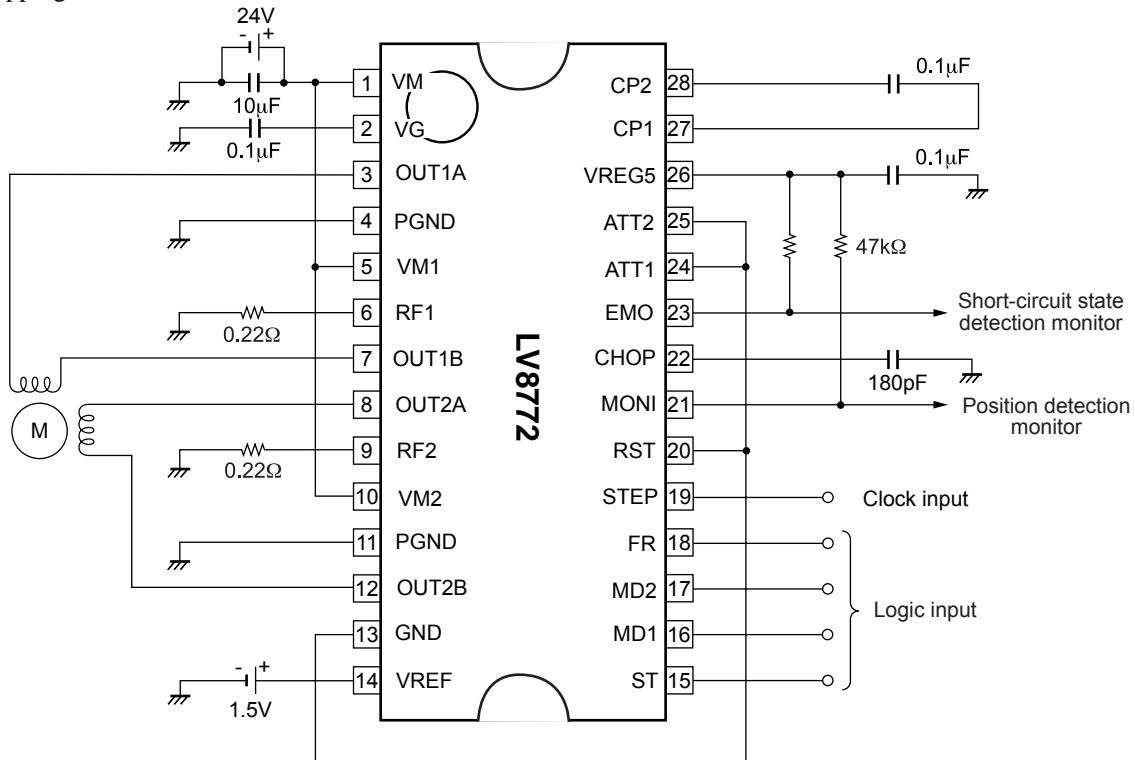

The formulae for setting the constants in the examples of the application circuits above are as follows :

Constant current (100%) setting

When VREF = 1.5V

$$I_{OUT} = VREF/5/RF \text{ resistance}$$

$$= 1.5V/5/0.22\Omega = 1.36A$$

Chopping frequency setting

$$F_{chop} = I_{chop}/(C_{chop} \times V_{tchop} \times 2)$$

$$= 10\mu A/(180pF \times 0.5V \times 2) = 55kHz$$

- SANYO Semiconductor Co.,Ltd. assumes no responsibility for equipment failures that result from using products at values that exceed, even momentarily, rated values (such as maximum ratings, operating condition ranges, or other parameters) listed in products specifications of any and all SANYO Semiconductor Co.,Ltd. products described or contained herein.
- SANYO Semiconductor Co.,Ltd. strives to supply high-quality high-reliability products, however, any and all semiconductor products fail or malfunction with some probability. It is possible that these probabilistic failures or malfunction could give rise to accidents or events that could endanger human lives, trouble that could give rise to smoke or fire, or accidents that could cause damage to other property. When designing equipment, adopt safety measures so that these kinds of accidents or events cannot occur. Such measures include but are not limited to protective circuits and error prevention circuits for safe design, redundant design, and structural design.
- In the event that any or all SANYO Semiconductor Co.,Ltd. products described or contained herein are controlled under any of applicable local export control laws and regulations, such products may require the export license from the authorities concerned in accordance with the above law.
- No part of this publication may be reproduced or transmitted in any form or by any means, electronic or mechanical, including photocopying and recording, or any information storage or retrieval system, or otherwise, without the prior written consent of SANYO Semiconductor Co.,Ltd.
- Any and all information described or contained herein are subject to change without notice due to product/technology improvement, etc. When designing equipment, refer to the "Delivery Specification" for the SANYO Semiconductor Co.,Ltd. product that you intend to use.
- Upon using the technical information or products described herein, neither warranty nor license shall be granted with regard to intellectual property rights or any other rights of SANYO Semiconductor Co.,Ltd. or any third party. SANYO Semiconductor Co.,Ltd. shall not be liable for any claim or suits with regard to a third party's intellectual property rights which has resulted from the use of the technical information and products mentioned above.

This catalog provides information as of September, 2011. Specifications and information herein are subject to change without notice.