

FEATURES

- Available in Space Saving SO-8 Package
- Output Current: 100mA
- Low Loss: 1.1V at 100mA
- Operating Range: 3.5V to 15V
- Reference and Error Amplifier for Regulation
- External Shutdown
- External Oscillator Synchronization
- Can Be Paralleled
- Pin Compatible with the LTC[®]1044/LTC7660

APPLICATIONS

- Voltage Inverter
- Voltage Regulator
- Negative Voltage Doubler
- Positive Voltage Doubler

DESCRIPTION

The LT[®]1054 is a monolithic, bipolar, switched-capacitor voltage converter and regulator. The LT1054 provides higher output current than previously available converters with significantly lower voltage losses. An adaptive switch driver scheme optimizes efficiency over a wide range of output currents. Total voltage loss at 100mA output current is typically 1.1V. This holds true over the full supply voltage range of 3.5V to 15V. Quiescent current is typically 2.5mA.

The LT1054 also provides regulation, a feature not previously available in switched-capacitor voltage converters. By adding an external resistive divider a regulated output can be obtained. This output will be regulated against changes in both input voltage and output current. The LT1054 can also be shut down by grounding the feedback pin. Supply current in shutdown is less than 100 μ A.

The internal oscillator of the LT1054 runs at a nominal frequency of 25kHz. The oscillator pin can be used to adjust the switching frequency or to externally synchronize the LT1054.

The LT1054 is pin compatible with previous converters such the LTC1044/LTC7660.

 LTC and LT are registered trademarks of Linear Technology Corporation.

BLOCK DIAGRAM

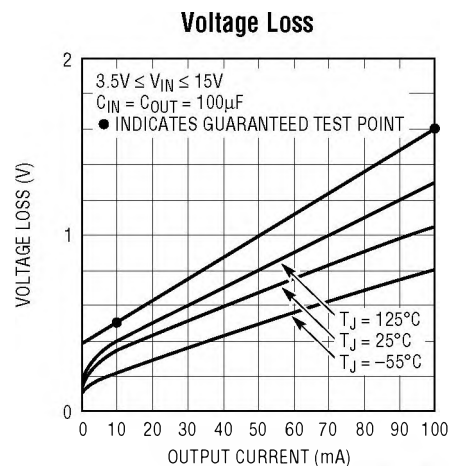
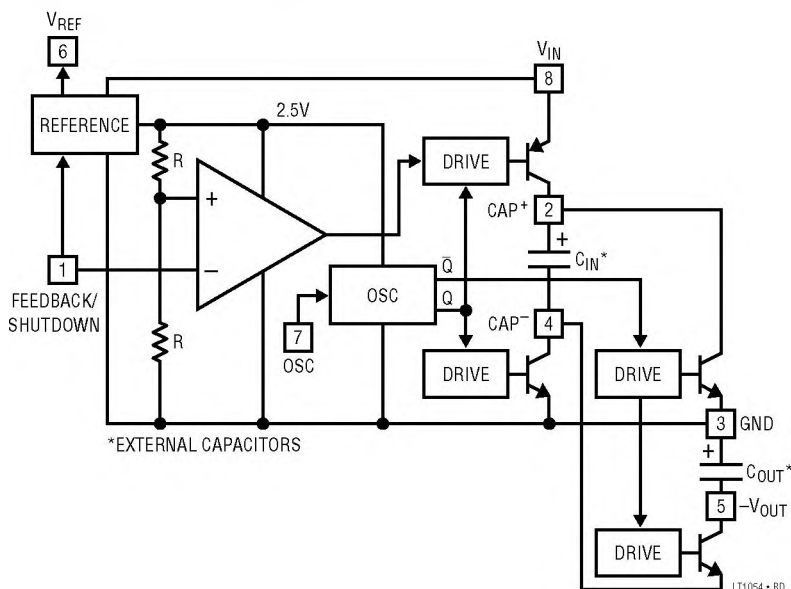

ABSOLUTE MAXIMUM RATINGS

Supply Voltage (Note 1).....	16V
Input Voltage	
Pin 1	$0V \leq V_{PIN1} \leq V^+$
Pin 3 (S Package)	$0V \leq V_{PIN3} \leq V^+$
Pin 7	$0V \leq V_{PIN7} \leq V_{REF}$
Pin 13 (S Package)	$0V \leq V_{PIN13} \leq V_{REF}$
Operating Temperature Range	
LT1054C	0°C to 70°C
LT1054I	-40°C to 85°C
LT1054M	-55°C to 125°C

Junction Temperature Range (Note 2)	
LT1054C	125°C
LT1054I	125°C
LT1054M	150°C
Storage Temperature Range	
H, J8, N8 and S8 Packages	-55°C to 150°C
S Package	-65°C to 150°C
Lead Temperature (Soldering, 10 sec)	300°C

PACKAGE/ORDER INFORMATION (Note 6)

<p>TOP VIEW</p> <p>H PACKAGE 8-LEAD TO-5 METAL CAN</p> <p>$T_{JMAX} = 150^{\circ}C, \theta_{JA} = 150^{\circ}C/W, \theta_{JC} = 45^{\circ}C/W$</p>	<p>ORDER PART NUMBER</p> <p>LT1054CH LT1054MH</p>	<p>TOP VIEW</p> <p>S8 PACKAGE 8-LEAD PLASTIC SO</p> <p>$T_{JMAX} = XXX^{\circ}C, \theta_{JA} = XXX^{\circ}C/W$</p> <p>SEE REGULATION AND CAPACITOR SELECTION SECTIONS IN THE APPLICATIONS INFORMATION FOR IMPORTANT INFORMATION ON THE S8 DEVICE</p>	<p>ORDER PART NUMBER</p> <p>LT1054CS8</p> <p>S8 PART MARKING</p> <p>1054</p>
<p>TOP VIEW</p> <p>J8 PACKAGE N8 PACKAGE 8-LEAD CERAMIC DIP 8-LEAD PLASTIC DIP</p> <p>$T_{JMAX} = 150^{\circ}C, \theta_{JA} = 100^{\circ}C/W$ (J8) $T_{JMAX} = 125^{\circ}C, \theta_{JA} = 130^{\circ}C/W$ (N8)</p>	<p>ORDER PART NUMBER</p> <p>LT1054CJ8 LT1054CN8 LT1054IN8 LT1054MJ8</p>	<p>TOP VIEW</p> <p>S PACKAGE 16-LEAD PLASTIC SOL</p> <p>$T_{JMAX} = 125^{\circ}C, \theta_{JA} = 150^{\circ}C/W$</p> <p>NOT RECOMMENDED FOR NEW DESIGNS</p>	<p>ORDER PART NUMBER</p> <p>LT1054CS LT1054IS</p>

ELECTRICAL CHARACTERISTICS (Note 6)

PARAMETER	CONDITIONS	MIN	TYP	MAX	UNITS	
Supply Current	$I_{LOAD} = 0mA$ $V_{IN} = 3.5V$ $V_{IN} = 15V$	●	2.5	4.0	mA	
		●	3.0	5.0	mA	
Supply Voltage Range		●	3.5	15	V	
Voltage Loss ($V_{IN} - V_{OUT} $)	$C_{IN} = C_{OUT} = 100\mu F$ Tantalum (Note 3) $I_{OUT} = 10mA$ $I_{OUT} = 100mA$	●	0.35	0.55	V	
		●	1.10	1.60	V	
Output Resistance	$\Delta I_{OUT} = 10mA$ to $100mA$ (Note 4)	●	10	15	Ω	
Oscillator Frequency	$3.5V \leq V_{IN} \leq 15V$	●	15	25	35	kHz
Reference Voltage	$I_{REF} = 60\mu A$, $T_J = 25^\circ C$	●	2.35	2.50	2.65	V
		●	2.25	2.75		V
Regulated Voltage	$V_{IN} = 7V$, $T_J = 25^\circ C$, $R_L = 500\Omega$ (Note 5)		-4.70	-5.00	-5.20	V
Line Regulation	$7V \leq V_{IN} \leq 12V$, $R_L = 500\Omega$ (Note 5)	●	5	25	mV	
Load Regulation	$V_{IN} = 7V$, $100\Omega \leq R_L \leq 500\Omega$ (Note 5)	●	10	50	mV	
Maximum Switch Current			300		mA	
Supply Current in Shutdown	$V_{PIN1} = 0V$	●	100	200	μA	

The ● denotes specifications which apply over the full operating temperature range. For C grade parts these specifications also apply up to a junction temperature of 100°C.

Note 1: The absolute maximum supply voltage rating of 16V is for unregulated circuits. For regulation mode circuits with $V_{OUT} \leq 15V$ at pin 5, (pin 11 S package) this rating may be increased to 20V.

Note 2: The devices are guaranteed by design to be functional up to the absolute maximum junction temperature.

Note 3: For voltage loss tests, the device is connected as a voltage inverter, with pins 1, 6, and 7 (3, 12, and 13 S package) unconnected. The voltage losses may be higher in other configurations.

Note 4: Output resistance is defined as the slope of the curve, (ΔV_{OUT} vs ΔI_{OUT}), for output currents of 10mA to 100mA. This represents the linear portion of the curve. The incremental slope of the curve will be higher at currents < 10mA due to the characteristics of the switch transistors.

Note 5: All regulation specifications are for a device connected as a positive-to-negative converter/regulator with $R1 = 20k$, $R2 = 102.5k$, $C1 = 0.002\mu F$, ($C1 = 0.05\mu F$ S package) $C_{IN} = 10\mu F$ tantalum, $C_{OUT} = 100\mu F$ tantalum.

Note 6: The S8 package uses a different die than the H, J8, N8 and S packages. The S8 device will meet all the existing data sheet parameters. See Regulation and Capacitor Selection in the Applications Information section for differences in application requirements.

TYPICAL PERFORMANCE CHARACTERISTICS

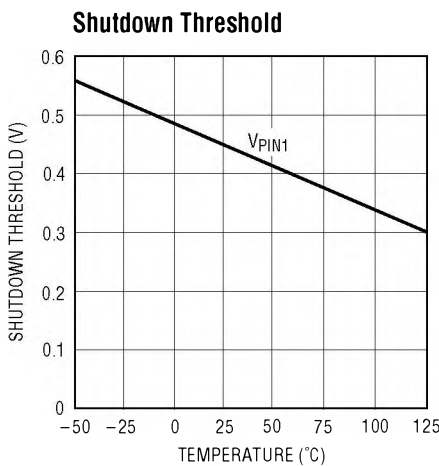

LT1054 • TPC01

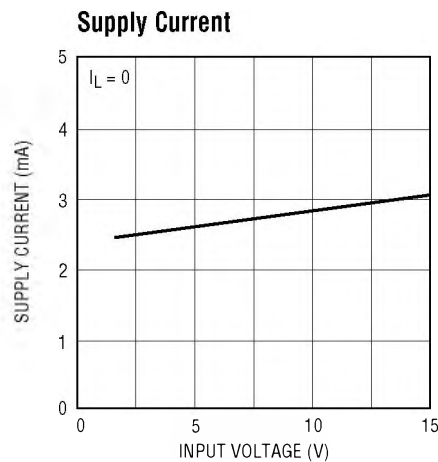

LT1054 • TPC02

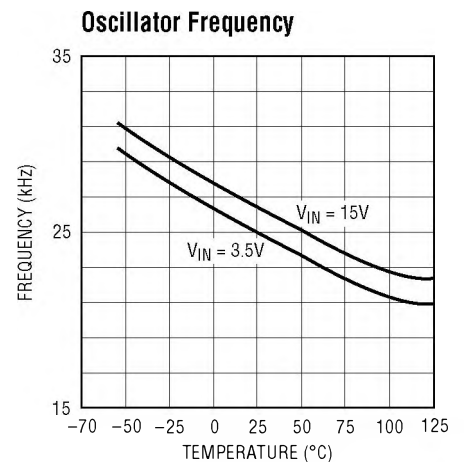

LT1054 • TPC03

TYPICAL PERFORMANCE CHARACTERISTICS

Supply Current in Shutdown

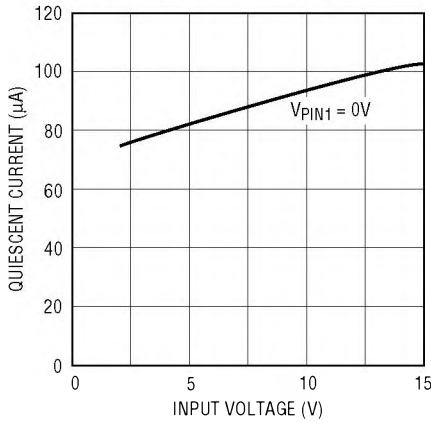

LT1054 • TPC04

Average Input Current

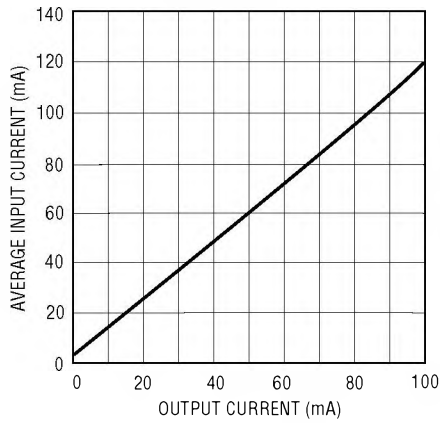

LT1050 • TPC05

Output Voltage Loss

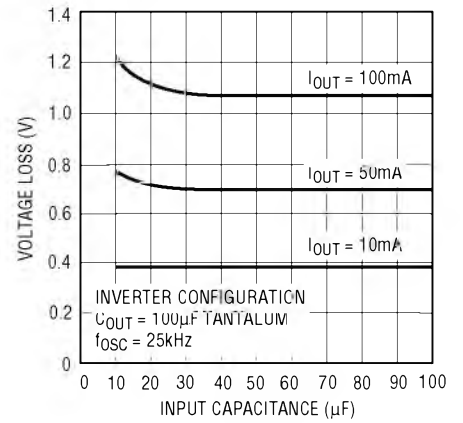

LT1054 • TPC06

Output Voltage Loss

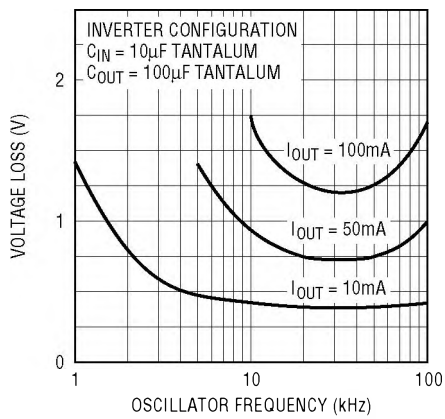

LT1054 • TPC07

Output Voltage Loss

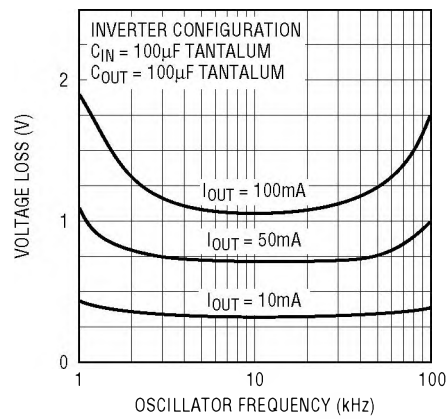

LT1054 • TPC08

Regulated Output Voltage

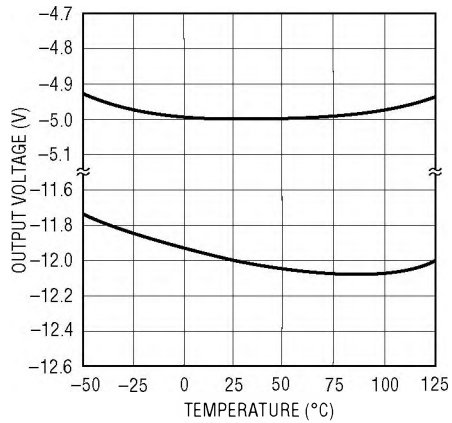

LT1054 • TPC09

Reference Voltage Temperature Coefficient

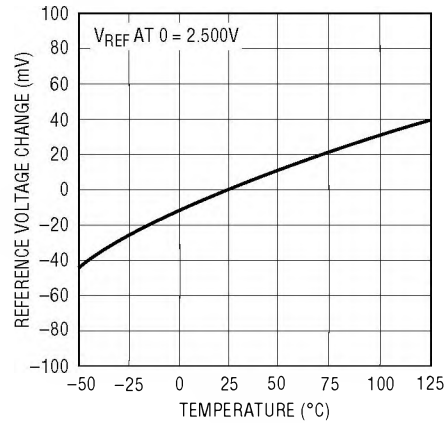

LT1054 • TPC10

PIN FUNCTIONS

V⁺ (Pin 8): Input Supply. The LT1054 alternately charges C_{IN} to the input voltage when C_{IN} is switched in parallel with the input supply and then transfers charge to C_{OUT} when C_{IN} is switched in parallel with C_{OUT}. Switching occurs at the oscillator frequency. During the time that C_{IN} is charging, the peak supply current will be approximately equal to 2.2 times the output current. During the time that C_{IN} is delivering charge to C_{OUT} the supply current drops to approximately 0.2 times the output current. An input supply bypass capacitor will supply part of the peak input current drawn by the LT1054 and average out the current drawn from the supply. A minimum input supply bypass capacitor of 2μF, preferably tantalum or some other low ESR type is recommended. A larger capacitor may be desirable in some cases, for example, when the actual input supply is connected to the LT1054 through long leads, or when the pulse current drawn by the LT1054 might affect other circuitry through supply coupling.

V_{OUT} (Pin 5): In addition to being the output pin the pin is also tied to the substrate of the device. **Special care must be taken in LT1054 circuits to avoid pulling this pin positive with respect to any of the other pins.** Pulling pin 5 positive with respect to pin 3 (GND) will forward bias the substrate diode which will prevent the device from starting. This condition can occur when the output load driven by the LT1054 is referred to its positive supply (or to some other positive voltage). Note that most op amps present just such a load since their supply currents flow from their V⁺ terminals to their V⁻ terminals. To prevent start-up problems with this type of load an external transistor must be added as shown in Figure 1. This will prevent V_{OUT} (pin 5) from being pulled above the ground pin (pin 3) during start-up. Any small, general purpose transistor such as 2N2222 or 2N2219 can be used. R_X should be chosen to provide enough base drive to the external transistor so that it is saturated under nominal output voltage and maximum output current conditions. In some cases an N-channel enhancement mode MOSFET can be used in place of the transistor.

$$R_X \leq \frac{(I_{V_{OUT}})\beta}{I_{OUT}}$$

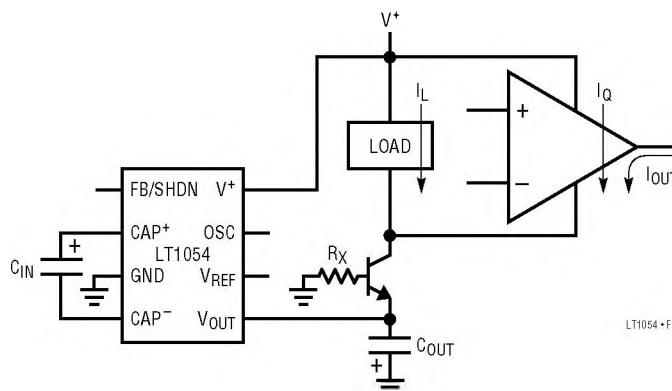

Figure 1

V_{REF} (Pin 6): Reference Output. This pin provides a 2.5V reference point for use in LT1054-based regulator circuits. The temperature coefficient of the reference voltage has been adjusted so that the temperature coefficient of the regulated output voltage is close to zero. This requires the reference output to have a positive temperature coefficient as can be seen in the typical performance curves. This nonzero drift is necessary to offset a drift term inherent in the internal reference divider and comparator network tied to the feedback pin. The overall result of these drift terms is a regulated output which has a slight positive temperature coefficient at output voltages below 5V and a slight negative TC at output voltages above 5V. Reference output current should be limited, for regulator feedback networks, to approximately 60μA. The reference pin will draw ≈100μA when shorted to ground and will not affect the internal reference/regulator, so that this pin can also be used as a pull-up for LT1054 circuits that require synchronization.

CAP⁺/CAP⁻ (Pin 2/Pin 4): Pin 2, the positive side of the input capacitor (C_{IN}), is alternately driven between V⁺ and ground. When driven to V⁺, pin 2 sources current from V⁺. When driven to ground pin 2 sinks current to ground. Pin 4, the negative side of the input capacitor, is driven alternately between ground the V_{OUT}. When driven to ground, pin 4 sinks current to ground. When driven to V_{OUT} pin 4 sources current from C_{OUT}. In all cases current flow in the switches is unidirectional as should be expected using bipolar switches.

PIN FUNCTIONS

OSC (Pin 7): Oscillator Pin. This pin can be used to raise or lower the oscillator frequency or to synchronize the device to an external clock. Internally pin 7 is connected to the oscillator timing capacitor ($C_t \approx 150\text{pF}$) which is alternately charged and discharged by current sources of $\pm 7\mu\text{A}$ so that the duty cycle is $\approx 50\%$. The LT1054 oscillator is designed to run in the frequency band where switching losses are minimized. However the frequency can be raised, lowered, or synchronized to an external system clock if necessary.

The frequency can be lowered by adding an external capacitor (C_1 , Figure 2) from pin 7 to ground. This will increase the charge and discharge times which lowers the oscillator frequency. The frequency can be increased by adding an external capacitor (C_2 , Figure 2, in the range of 5pF to 20pF) from pin 2 to pin 7. This capacitor will couple charge into C_t at the switch transitions, which will shorten the charge and discharge time, raising the oscillator frequency. Synchronization can be accomplished by adding an external resistive pull-up from pin 7 to the reference pin (pin 6). A $20\text{k}\Omega$ pull-up is recommended. An open collector gate or an NPN transistor can then be used to drive the oscillator pin at the external clock frequency as shown in Figure 2. Pulling up pin 7 to an external voltage is **not recommended**. For circuits that require both fre-

quency synchronization and regulation, an external reference can be used as the reference point for the top of the R_1/R_2 divider allowing pin 6 to be used as a pull-up point for pin 7.

FB/SHDN (Pin 1): Feedback/Shutdown Pin. This pin has two functions. Pulling pin 1 below the shutdown threshold ($\approx 0.45\text{V}$) puts the device into shutdown. In shutdown the reference/regulator is turned off and switching stops. The switches are set such that both C_{IN} and C_{OUT} are discharged through the output load. Quiescent current in shutdown drops to approximately $100\mu\text{A}$ (see Typical Performance Characteristics). Any open-collector gate can be used to put the LT1054 into shutdown. For normal (unregulated) operation the device will start back up when the external gate is shut off. In LT1054 circuits that use the regulation feature, the external resistor divider can provide enough pull-down to keep the device in shutdown until the output capacitor (C_{OUT}) has fully discharged. For most applications where the LT1054 would be run intermittently, this does not present a problem because the discharge time of the output capacitor will be short compared to the off-time of the device. In applications where the device has to start up before the output capacitor (C_{OUT}) has fully discharged, a restart pulse must be applied to pin 1 of the LT1054. Using the circuit of Figure 5, the restart signal can be either a pulse ($t_p > 100\mu\text{s}$) or a logic high. Diode coupling the restart signal into pin 1 will allow the output voltage to come up and regulate without overshoot. The resistor divider R_3/R_4 in Figure 5 should be chosen to provide a signal level at pin 1 of 0.7V to 1.1V .

Pin 1 is also the inverting input of the LT1054's error amplifier and as such can be used to obtain a regulated output voltage.

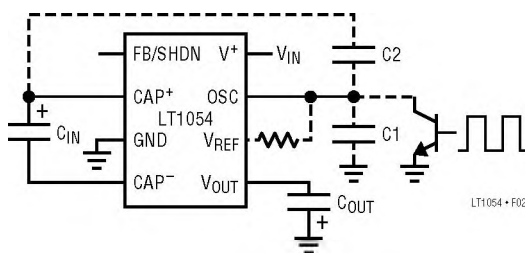

Figure 2

APPLICATIONS INFORMATION

Theory of Operation

To understand the theory of operation of the LT1054, a review of a basic switched-capacitor building block is helpful.

In Figure 3 when the switch is in the left position, capacitor C1 will charge to voltage V1. The total charge on C1 will be $q_1 = C1V_1$. The switch then moves to the right, discharging C1 to voltage V2. After this discharge time the charge on C1 is $q_2 = C1V_2$. Note that charge has been transferred from the source V1 to the output V2. The amount of charge transferred is:

$$\Delta q = q_1 - q_2 = C1(V_1 - V_2)$$

If the switch is cycled f times per second, the charge transfer per unit time (i.e., current) is:

$$I = f \times \Delta q = f \times C1(V_1 - V_2)$$

To obtain an equivalent resistance for the switched-capacitor network we can rewrite this equation in terms of voltage and impedance equivalence:

$$I = \frac{V_1 - V_2}{(1/fC1)} = \frac{V_1 - V_2}{R_{EQUIV}}$$

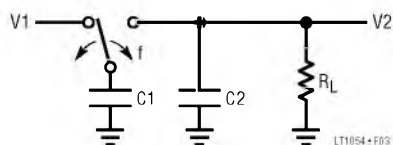

Figure 3. Switched-Capacitor Building Block

A new variable R_{EQUIV} is defined such that $R_{EQUIV} = 1/fC1$. Thus the equivalent circuit for the switched-capacitor network is as shown in Figure 4. The LT1054 has the same switching action as the basic switched-capacitor building block. Even though this simplification doesn't include finite switch on-resistance and output voltage ripple, it provides an intuitive feel for how the device works.

These simplified circuits explain voltage loss as a function of frequency (see Typical Performance Characteristics). As frequency is decreased, the output impedance will eventually be dominated by the $1/fC1$ term and voltage losses will rise.

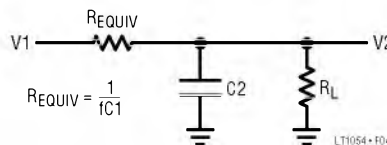

Figure 4. Switched-Capacitor Equivalent Circuit

Note that losses also rise as frequency increases. This is caused by internal switching losses which occur due to some finite charge being lost on each switching cycle. This charge loss per-unit-cycle, when multiplied by the switching frequency, becomes a current loss. At high frequency this loss becomes significant and voltage losses again rise.

The oscillator of the LT1054 is designed to run in the frequency band where voltage losses are at a minimum.

Regulation

The error amplifier of the LT1054 servos the drive to the PNP switch to control the voltage across the input capacitor (C_{IN}) which in turn will determine the output voltage. Using the reference and error amplifier of the LT1054, an external resistive divider is all that is needed to set the regulated output voltage. Figure 5 shows the basic regulator configuration and the formula for calculating the appropriate resistor values. R1 should be chosen to be

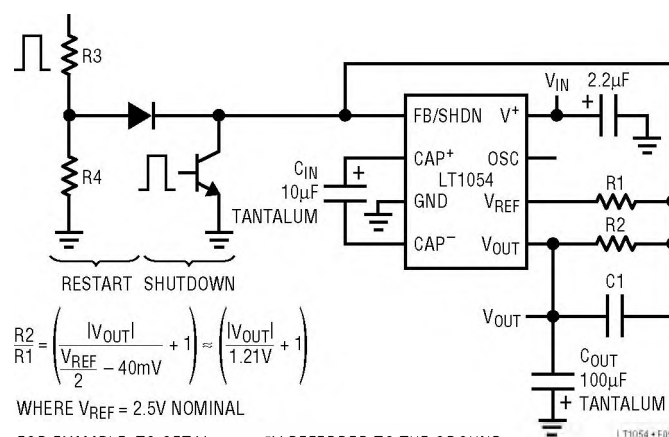

$$\frac{R_2}{R_1} = \left(\frac{|V_{OUT}|}{\frac{V_{REF}}{2} - 40\text{mV}} + 1 \right) = \left(\frac{|V_{OUT}|}{1.21\text{V}} + 1 \right)$$

WHERE $V_{REF} = 2.5\text{V}$ NOMINAL

FOR EXAMPLE: TO GET $V_{OUT} = -5\text{V}$ REFERRED TO THE GROUND PIN OF THE LT1054, CHOOSE $R_1 = 20\text{k}$, THEN

$$R_2 = 20\text{k} \left(\frac{|-5\text{V}|}{\frac{2.5\text{V}}{2} - 40\text{mV}} + 1 \right) = 102.6\text{k}^*$$

*CHOOSE THE CLOSEST 1% VALUE

Figure 5

APPLICATIONS INFORMATION

20k or greater because the reference output current is limited to $\approx 100\mu\text{A}$. R2 should be chosen to be in the range of 100k to 300k. For optimum results the ratio of $C_{\text{IN}}/C_{\text{OUT}}$ is recommended to be 1/10. C1, required for good load regulation at light load currents, should be 0.002 μF for all output voltages.

A new die layout was required to fit into the physical dimensions of the S8 package. Although the new die of the LT1054CS8 will meet all the specifications of the existing LT1054 data sheet, subtle differences in the layout of the new die require consideration in some application circuits. In regulating mode circuits using the 1054CS8 the nominal values of the capacitors, C_{IN} and C_{OUT} , must be approximately equal for proper operation at elevated junction temperatures. This is different from the earlier part. Mismatches within normal production tolerances for the capacitors are acceptable. Making the nominal capacitor values equal will ensure proper operation at elevated junction temperatures at the cost of a small degradation in the transient response of regulator circuits. For unregulated circuits the values of C_{IN} and C_{OUT} are normally equal for all packages. For S8 applications assistance in unusual applications circuits, please consult the factory.

It can be seen from the circuit block diagram that the maximum regulated output voltage is limited by the supply voltage. For the basic configuration, $|V_{\text{OUT}}|$ referred to the ground pin of the LT1054 must be less than the total of the supply voltage minus the voltage loss due to the switches. The voltage loss versus output current due to the switches can be found in Typical Performance Characteristics. Other configurations such as the negative doubler can provide higher output voltages at reduced output currents (see Typical Applications).

Capacitor Selection

For unregulated circuits the nominal values of C_{IN} and C_{OUT} should be equal. For regulated circuits see the section on Regulation. While the exact values of C_{IN} and C_{OUT} are noncritical, good quality, low ESR capacitors such as solid tantalum are necessary to minimize voltage losses at high currents. For C_{IN} the effect of the ESR of the capacitor will be multiplied by four due to the fact that switch currents are approximately two times higher than output current and

losses will occur on both the charge and discharge cycle. This means that using a capacitor with 1 Ω of ESR for C_{IN} will have the same effect as increasing the output impedance of the LT1054 by 4 Ω . This represents a significant increase in the voltage losses. For C_{OUT} the affect of ESR is less dramatic. C_{OUT} is alternately charged and discharged at a current approximately equal to the output current and the ESR of the capacitor will cause a step function to occur in the output ripple at the switch transitions. This step function will degrade the output regulation for changes in output load current and should be avoided. Realizing that large value tantalum capacitors can be expensive, a technique that can be used is to parallel a smaller tantalum capacitor with a large aluminum electrolytic capacitor to gain both low ESR and reasonable cost. Where physical size is a concern some of the newer chip type surface mount tantalum capacitors can be used. These capacitors are normally rated at working voltages in the 10V to 20V range and exhibit very low ESR (in the range of 0.1 Ω).

Output Ripple

The peak-to-peak output ripple is determined by the value of the output capacitor and the output current. Peak-to-peak output ripple may be approximated by the formula:

$$dV = \frac{I_{\text{OUT}}}{2fC_{\text{OUT}}}$$

where dV = peak-to-peak ripple and f = oscillator frequency.

For output capacitors with significant ESR a second term must be added to account for the voltage step at the switch transitions. This step is approximately equal to:

$$(2I_{\text{OUT}})(\text{ESR of } C_{\text{OUT}})$$

Power Dissipation

The power dissipation of any LT1054 circuit must be limited such that the junction temperature of the device does not exceed the maximum junction temperature ratings. The total power dissipation must be calculated from two components, the power loss due to voltage drops in the switches and the power loss due to drive current losses. The total power dissipated by the LT1054 can be calculated from:

APPLICATIONS INFORMATION

$$P \approx (V_{IN} - |V_{OUT}|)(I_{OUT}) + (V_{IN})(I_{OUT})(0.2)$$

where both V_{IN} and V_{OUT} are referred to the ground pin (pin 3) of the LT1054. For LT1054 regulator circuits, the power dissipation will be equivalent to that of a linear regulator. Due to the limited power handling capability of the LT1054 packages, the user will have to limit output current requirements or take steps to dissipate some power external to the LT1054 for large input/output differentials. This can be accomplished by placing a resistor in series with C_{IN} as shown in Figure 6. A portion of the input voltage will then be dropped across this resistor without affecting the output regulation. Because switch current is approximately 2.2

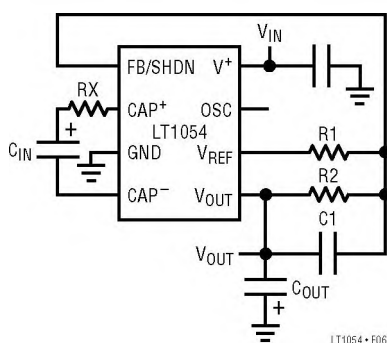

Figure 6

times the output current and the resistor will cause a voltage drop when C_{IN} is both charging and discharging, the resistor should be chosen as:

$$R_X = V_X / (4.4 I_{OUT})$$

where

$$V_X \approx V_{IN} - [(LT1054 \text{ Voltage Loss})(1.3) + |V_{OUT}|]$$

and I_{OUT} = maximum required output current. The factor of 1.3 will allow some operating margin for the LT1054.

For example: assume a 12V to -5V converter at 100mA output current. First calculate the power dissipation without an external resistor:

$$P = (12V - |-5V|)(100mA) + (12V)(100mA)(0.2)$$

$$P = 700mW + 240mW = 940mW$$

At θ_{JA} of 130°C/W for a commercial plastic device this would cause a junction temperature rise of 122°C so that the device would exceed the maximum junction temperature at an ambient temperature of 25°C. Now calculate the power dissipation with an external resistor (R_X). First find how much voltage can be dropped across R_X . The maximum voltage loss of the LT1054 in the standard regulator configuration at 100mA output current is 1.6V, so

$$V_X = 12V - [(1.6V)(1.3) + |-5V|] = 4.9V \text{ and}$$

$$R_X = 4.9V / (4.4)(100mA) = 11\Omega$$

This resistor will reduce the power dissipated by the LT1054 by $(4.9V)(100mA) = 490mW$. The total power dissipated by the LT1054 would then be $= (940mW - 490mW) = 450mW$. The junction temperature rise would now be only 58°C. Although commercial devices are guaranteed to be functional up to a junction temperature of 125°C, the specifications are only guaranteed up to a junction temperature of 100°C, so ideally you should limit the junction temperature to 100°C. For the above example this would mean limiting the ambient temperature to 42°C. Other steps can be taken to allow higher ambient temperatures. The thermal resistance numbers for the LT1054 packages represent worst case numbers with no heat sinking and still air. Small clip-on type heat sinks can be used to lower the thermal resistance of the LT1054 package. In some systems there may be some available airflow which will help to lower the thermal resistance. Wide PC board traces from the LT1054 leads can also help to remove heat from the device. This is especially true for plastic packages.

TYPICAL APPLICATIONS

Basic Voltage Inverter

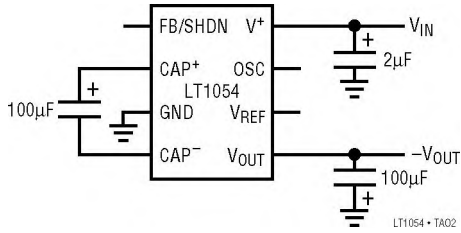

LT1054 • TA02

Basic Voltage Inverter/Regulator

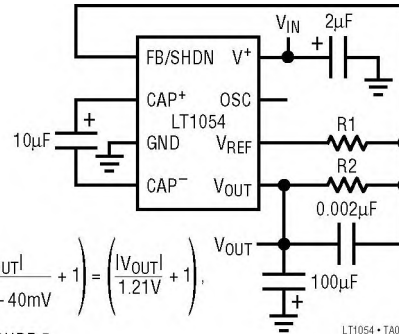

$$\frac{R2}{R1} = \left(\frac{|V_{OUT}|}{\frac{V_{REF}}{2} - 40mV} + 1 \right) = \left(\frac{|V_{OUT}|}{1.21V} + 1 \right)$$

REFER TO FIGURE 5

LT1054 • TA03

Negative Voltage Doubler

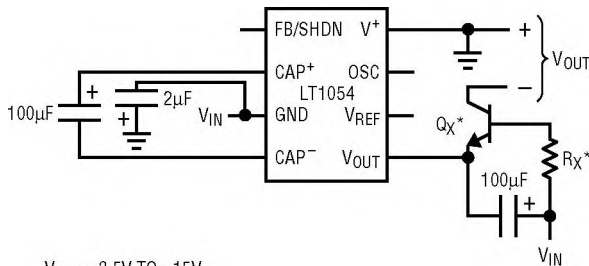

$V_{IN} = -3.5V \text{ TO } -15V$
 $V_{OUT} = 2V_{IN} + (\text{LT1054 VOLTAGE LOSS}) + (Q_X \text{ SATURATION VOLTAGE})$
 *SEE FIGURE 3

LT1054 • TA04

Positive Doubler

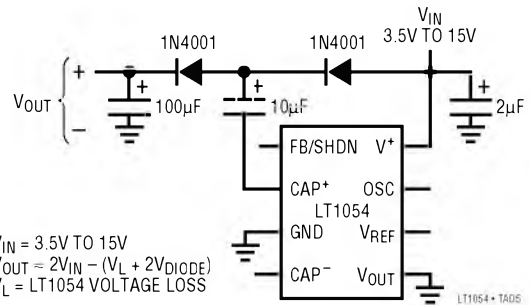

$V_{IN} = 3.5V \text{ TO } 15V$
 $V_{OUT} = 2V_{IN} - (V_L + 2V_{DIODE})$
 $V_L = \text{LT1054 VOLTAGE LOSS}$

LT1054 • TA05

100mA Regulating Negative Doubler

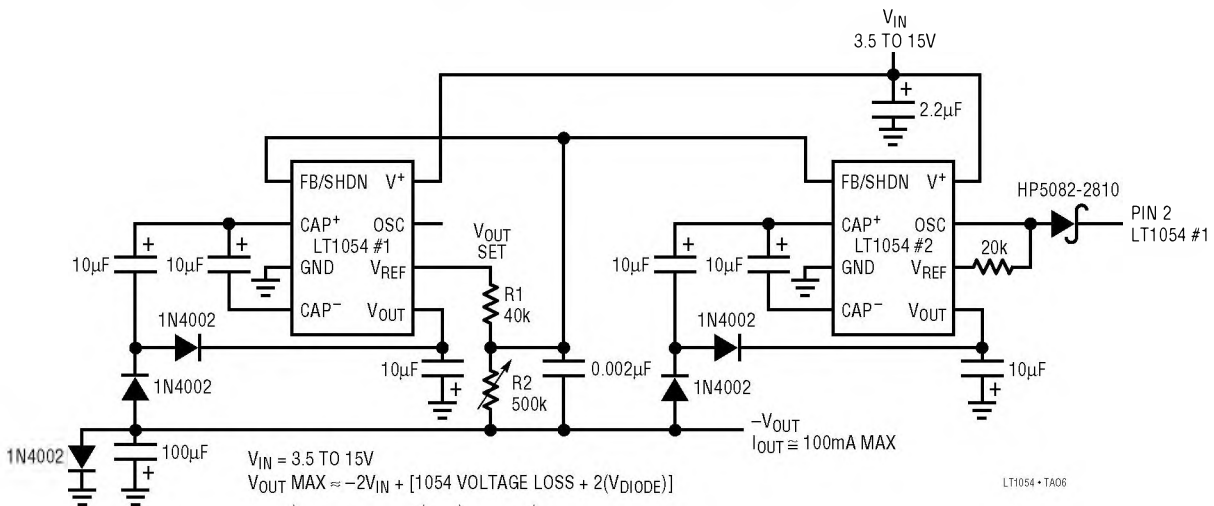

$V_{IN} = 3.5 \text{ TO } 15V$
 $V_{OUT \text{ MAX}} \approx -2V_{IN} + [1054 \text{ VOLTAGE LOSS} + 2(V_{DIODE})]$

$$\frac{R2}{R1} = \left(\frac{|V_{OUT}|}{\frac{V_{REF}}{2} - 40mV} + 1 \right) = \left(\frac{|V_{OUT}|}{1.21V} + 1 \right), \text{ REFER TO FIGURE 5}$$

LT1054 • TA06

TYPICAL APPLICATIONS

Strain Gauge Bridge Signal Conditioner

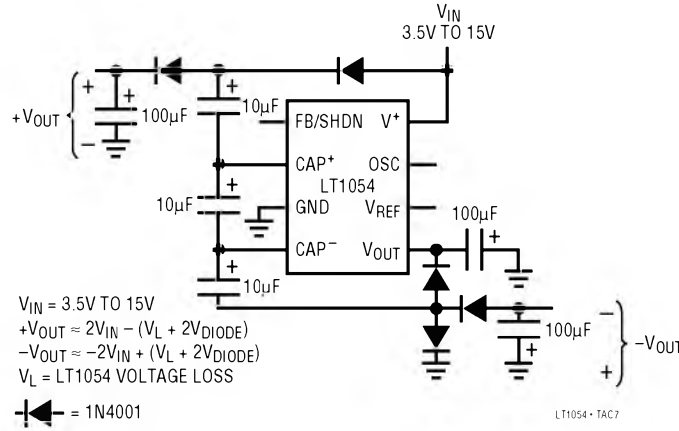

5V to ±12V Converter

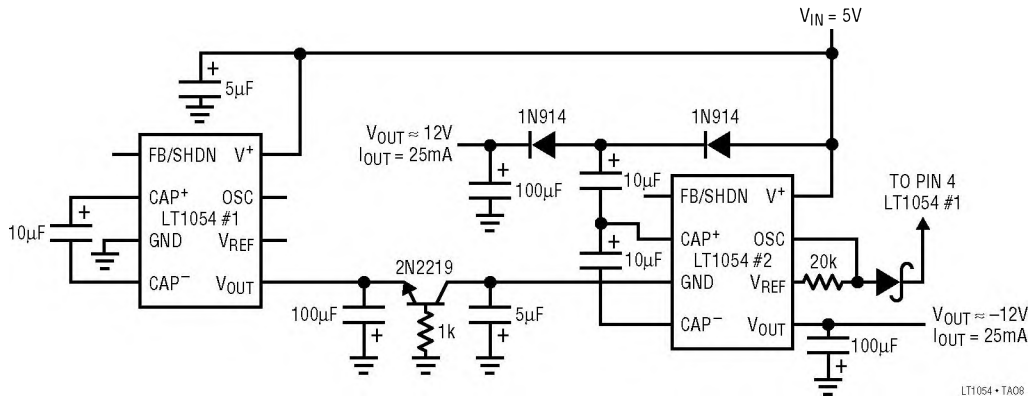

5V to ±12V Converter

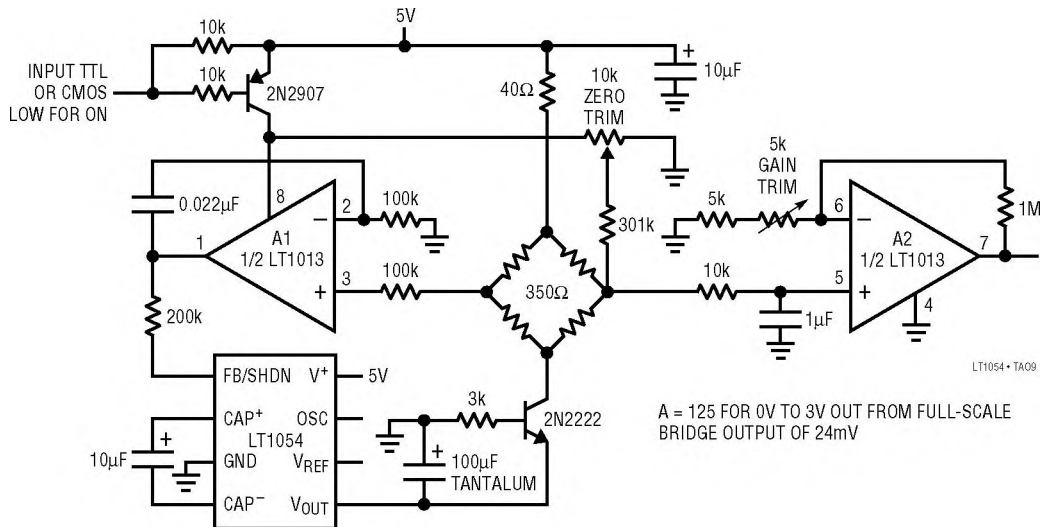

TYPICAL APPLICATIONS

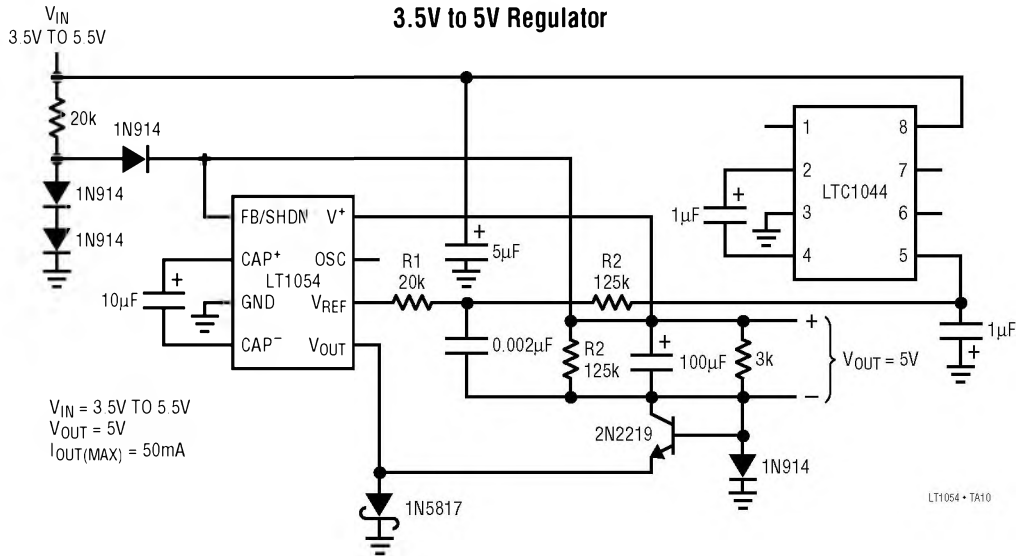

Regulating 200mA, 12V to -5V Converter

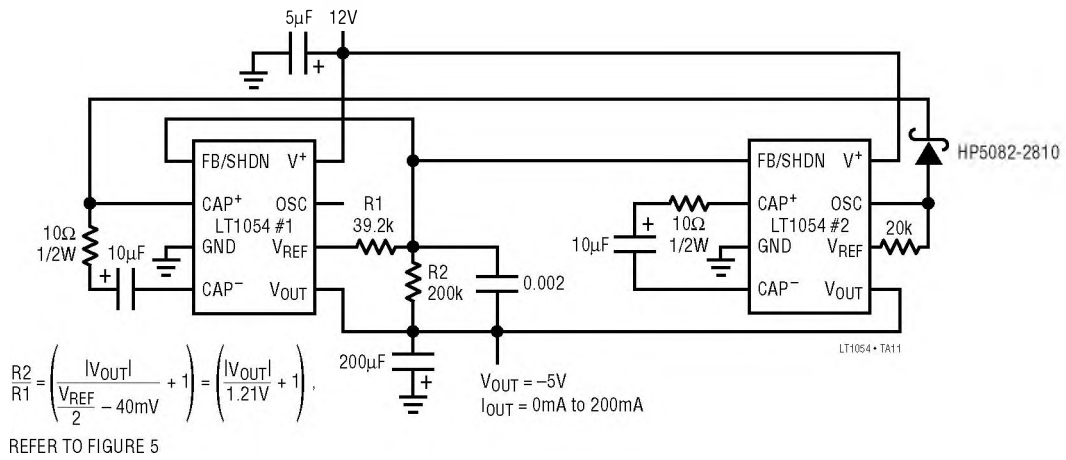

Digitally Programmable Negative Supply

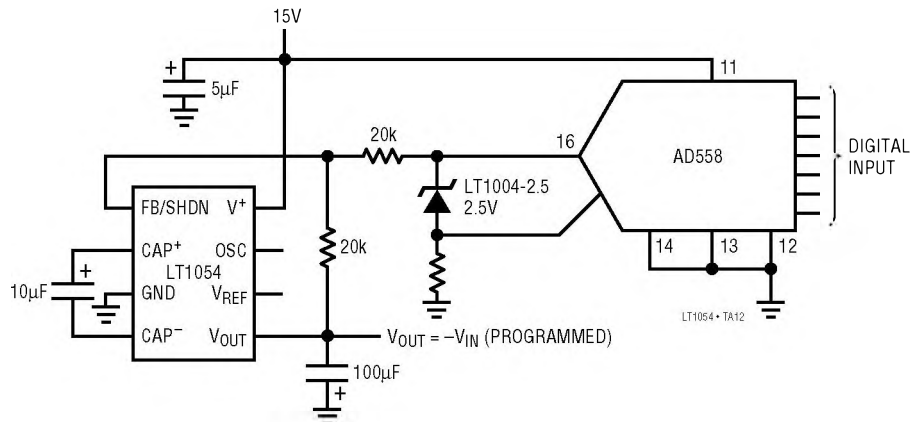

TYPICAL APPLICATIONS

**Positive Doubler with Regulation
(5V to 8V Converter)**

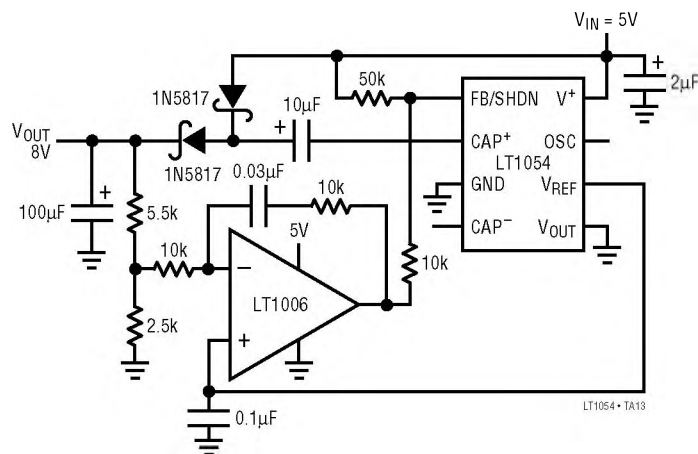

Negative Doubler with Regulator

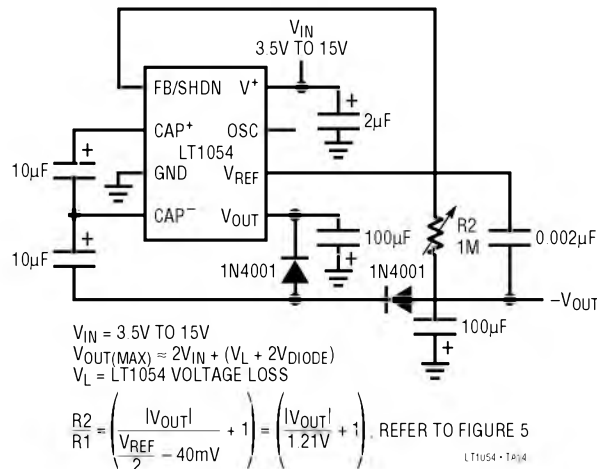

THE TYPICAL APPLICATIONS CIRCUITS WERE VERIFIED USING THE STANDARD LT1054. FOR S8 APPLICATIONS ASSISTANCE IN ANY OF THE UNUSUAL APPLICATIONS CIRCUITS PLEASE CONSULT THE FACTORY

PACKAGE DESCRIPTION

Dimension in inches (millimeters) unless otherwise noted.

**H Package
8-Lead TO-5 Metal Can**

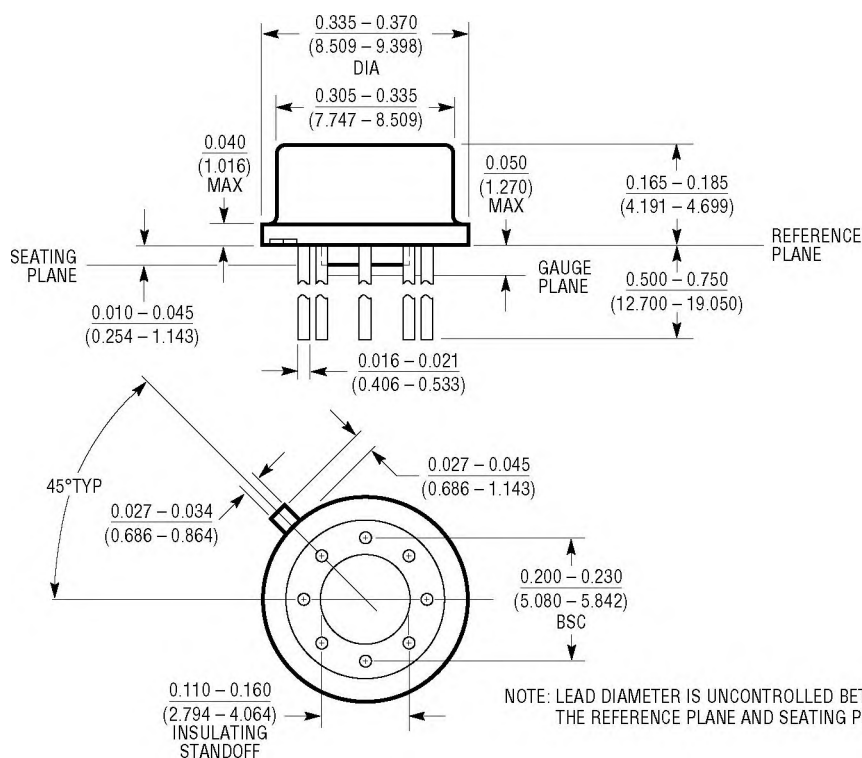

H8(S) 0592

PACKAGE DESCRIPTION Dimension in inches (millimeters) unless otherwise noted.

**J8 Package
8-Lead Ceramic DIP**

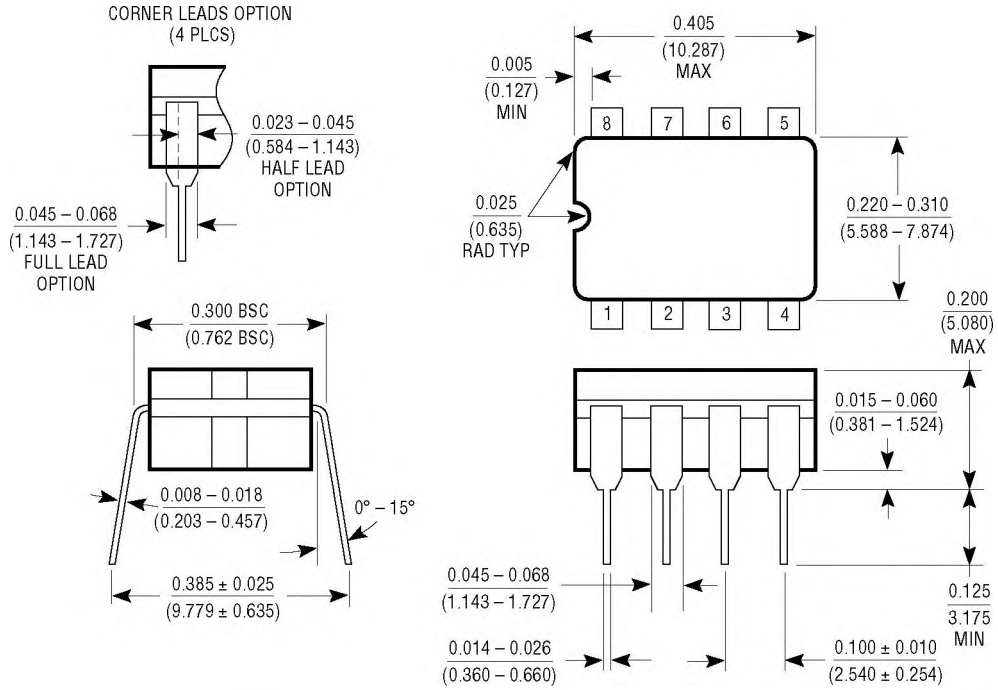

NOTE: LEAD DIMENSIONS APPLY TO SOLDER DIP OR TIN PLATE LEADS

J8 0594

**N8 Package
8-Lead Plastic DIP**

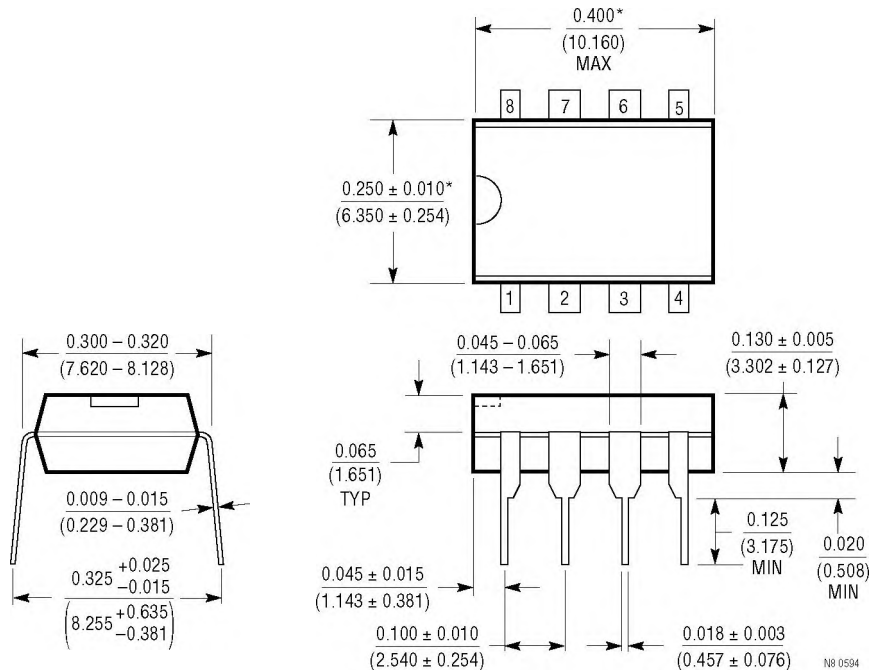

*THESE DIMENSIONS DO NOT INCLUDE MOLD FLASH OR PROTRUSIONS
MOLD FLASH OR PROTRUSIONS SHALL NOT EXCEED 0.010 INCH (0.254mm)

N8 0594

PACKAGE DESCRIPTION Dimension in inches (millimeters) unless otherwise noted.

**S8 Package
8-Lead Ceramic DIP**

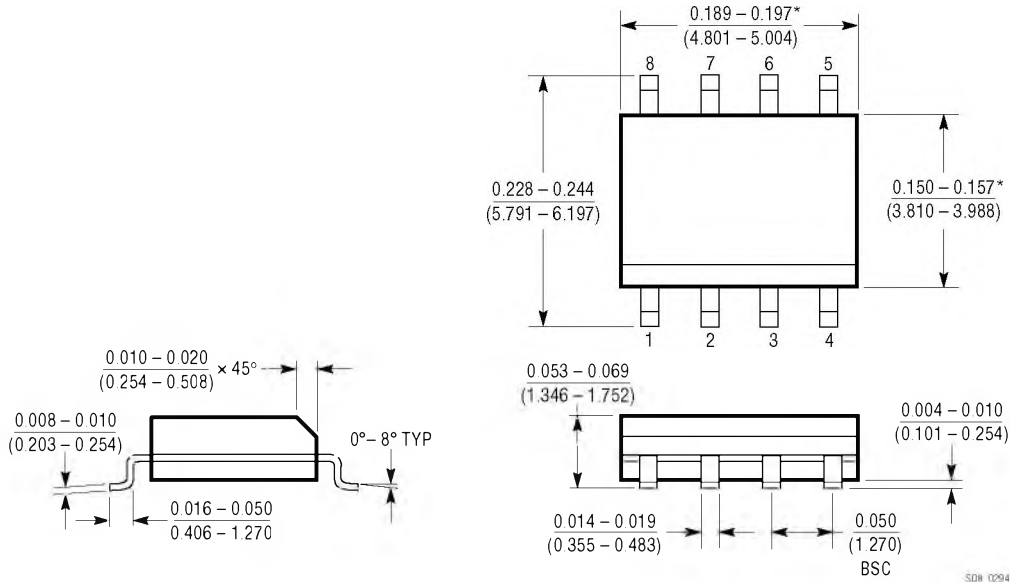

*THESE DIMENSIONS DO NOT INCLUDE MOLD FLASH OR PROTRUSIONS
MOLD FLASH OR PROTRUSIONS SHALL NOT EXCEED 0.006 INCH (0.15mm)

**S Package
16-Lead Plastic SOL**

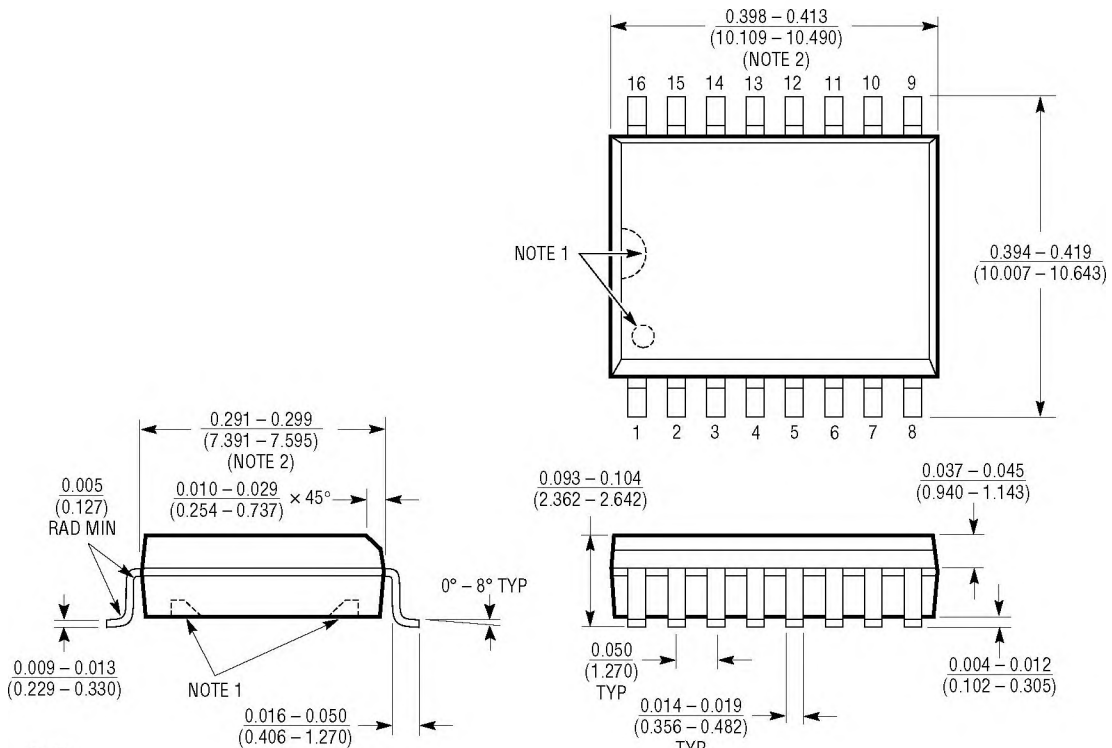

U.S. Area Sales Offices

NORTHEAST REGION

Linear Technology Corporation
 3220 Tillman Drive, Suite 120
 Bensalem, PA 19020
 Phone: (215) 638-9667
 FAX: (215) 638-9764

Linear Technology Corporation

266 Lowell St., Suite B-8
 Wilmington, MA 01887
 Phone: (508) 658-3881
 FAX: (508) 658-2701

SOUTHEAST REGION

Linear Technology Corporation
 17000 Dallas Parkway
 Suite 219
 Dallas, TX 75248
 Phone: (214) 733-3071
 FAX: (214) 380-5138

CENTRAL REGION

Linear Technology Corporation
 Chesapeake Square
 229 Mitchell Court, Suite A-25
 Addison, IL 60101
 Phone: (708) 620-6910
 FAX: (708) 620-6977

SOUTHWEST REGION

Linear Technology Corporation
 22141 Ventura Blvd.
 Suite 206
 Woodland Hills, CA 91364
 Phone: (818) 703-0835
 FAX: (818) 703-0517

NORTHWEST REGION

Linear Technology Corporation
 782 Sycamore Dr.
 Milpitas, CA 95035
 Phone: (408) 428-2050
 FAX: (408) 432-6331

International Sales Offices

FRANCE

Linear Technology S.A.R.L.
 Immeuble "Le Quartz"
 58 Chemin de la Justice
 92290 Chatenay Malabry
 France
 Phone: 33-1-41079555
 FAX: 33-1-46314613

GERMANY

Linear Technology GmbH
 Untere Hauptstr. 9
 D-85386 Eching
 Germany
 Phone: 49-89-3197410
 FAX: 49-89-3194821

JAPAN

Linear Technology KK
 5F NAO Bldg.
 1-14 Shin-Ogawa-cho Shinjuku-ku
 Tokyo, 162 Japan
 Phone: 81-3-3267-7891
 FAX: 81-3-3267-8510

KOREA

Linear Technology Korea Branch
 Namsong Building, #505
 Itaewon-Dong 260-199
 Yongsan-Ku, Seoul
 Korea
 Phone: 82-2-792-1617
 FAX: 82-2-792-1619

SINGAPORE

Linear Technology Pte. Ltd.
 507 Yishun Industrial Park A
 Singapore 2776
 Phone: 65-753-2692
 FAX: 65-754-4113

TAIWAN

Linear Technology Corporation
 Rm. 801, No. 46, Sec. 2
 Chung Shan N. Rd.
 Taipei, Taiwan, R.O.C.
 Phone: 886-2-521-7575
 FAX: 886-2-562-2285

UNITED KINGDOM

Linear Technology (UK) Ltd.
 The Coliseum, Riverside Way
 Camberley, Surrey GU15 3YL
 United Kingdom
 Phone: 44-1276-677676
 FAX: 44-1276-64851

World Headquarters

Linear Technology Corporation
 1630 McCarthy Blvd.
 Milpitas, CA 95035-7487
 Phone: (408) 432-1900
 FAX: (408) 434-0507

0295