



LINEAR INTEGRATED CIRCUIT

HIGH PERFORMANCE 80 dB COMPANDOR

The LS150 is a monolithic integrated circuit in 14-lead dual in-line ceramic and plastic packages; it performs signal level expansion in an 80-dB range [with an overall accuracy of ± 0.2 dB in a 60 dB range] and, when used in the feedback path of an operational amplifier, it performs complementary signal compression. The LS150 has been designed to improve audio channel signal-to-noise ratio according to CCITT recommendations which require an unaffected reference level of -14 dBm across 600Ω . The device can also be used to reduce crosstalk and may be converted into a unity gain amplifier for data transmission links by means of a simple switch without affecting output and input impedance levels. Another possible application is as a noise reducer and dynamic range expander in cassette tape recorders and intercoms.

ABSOLUTE MAXIMUM RATINGS

V_s	Supply voltage	24	V
I_{5-6}	Differential current between pins 5 and 6	20	mA
V_i	Common mode input voltage	V_s	
T_{stg}, T_j	Storage and junction temperature	-65 to 150	$^{\circ}\text{C}$
T_{op}	Operating temperature	-20 to 85	$^{\circ}\text{C}$

ORDERING NUMBERS: LS150 CD (Ceramic package)
 LS150 CB (Plastic package)

MECHANICAL DATA

Dimensions in mm

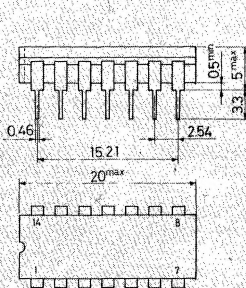

LS 150 CD

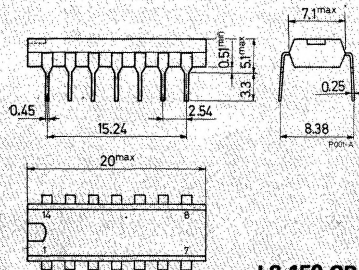

LS 150 CB



LS150

CONNECTION DIAGRAM

(top view)

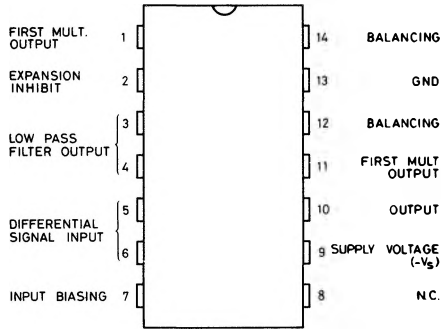

S-2119/1

BLOCK DIAGRAM

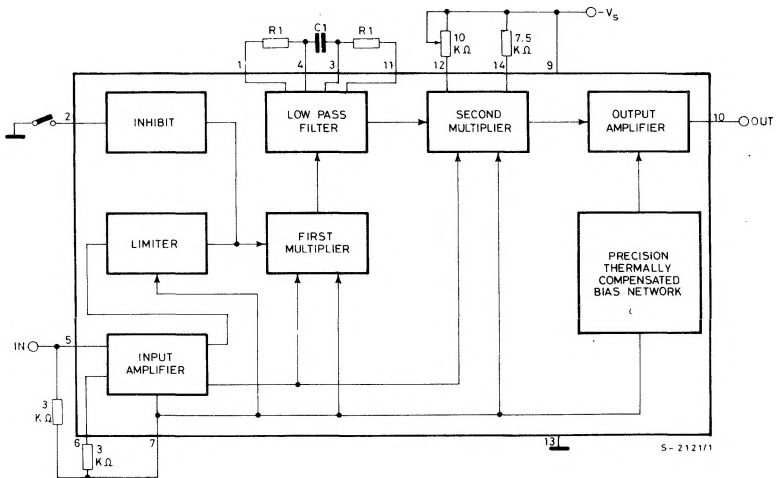

S-2121/1

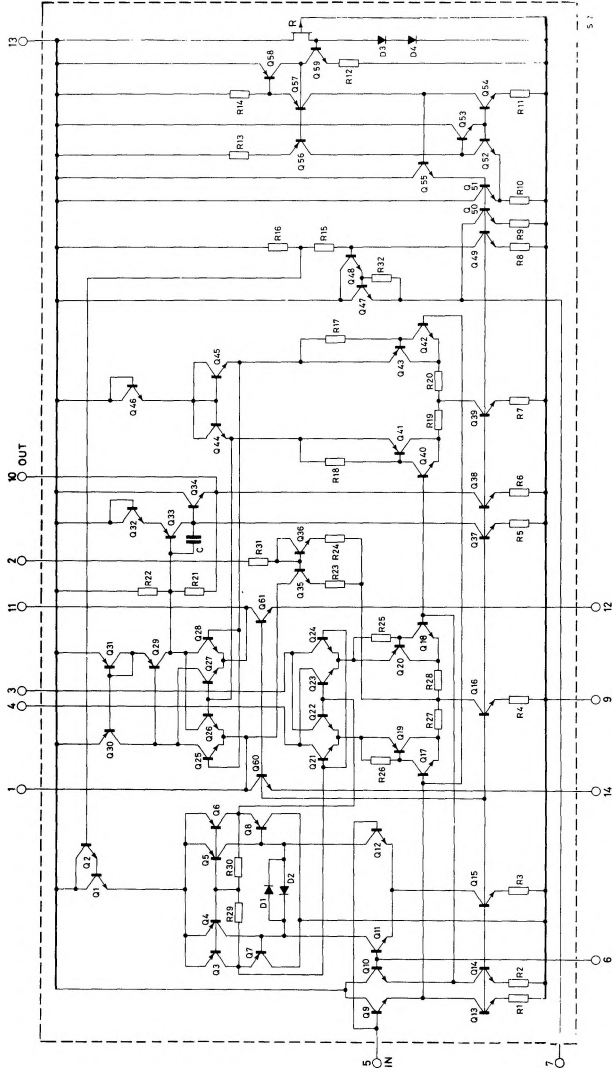
SCHEMATIC DIAGRAM

**LS150****THERMAL DATA**

		Plastic	Ceramic
$R_{th\ j-amb}$	Thermal resistance junction-ambient	max	100 °C/W
			120 °C/W

ELECTRICAL CHARACTERISTICS (Refer to the test circuit of fig. 1, $-V_s = -12V$; $T_{amb} = 25^\circ C$ unless otherwise specified)

Parameter		Test conditions	Min.	Typ.	Max.	Unit
I_s	Supply current			5	8	mA
R_7	Input dynamic biasing resistance (pin 7)	$L_i = -14\ dBv$ $f = 800\ Hz$ External time constant $2 R_1 \cdot C_1 = 20\ ms$		60	90	Ω
G_v	Gain		-1	0	+1	dB
ΔG_v	Gain variation	$T_{amb} = 5\ to\ 55^\circ C$ $\Delta V_s = \pm 2\ %$		± 0.2 ± 0.03		dB dB
B	Bandwith (-3 dB)			500		KHz
R_o	Output resistance			25	60	Ω
R_i	Input resistance (pin 5)	$L_i = -14\ dBv$ $f = 800\ Hz$		100		$K\Omega$
d	Distortion			0.7		%
d_3	Two-tone third order intermodulation	$f_1 = 900\ Hz$ $f_2 = 1020\ Hz$ $V_1 = V_2 = 88\ mV$		0.5		%
e_N	Output noise in psophometric band			-100		dBm
$\Delta G $	Expansion accuracy after balancing	$L_i = -40\ to\ -10\ dBv$, $f = 800\ Hz$ $T_{amb} = 5\ to\ 55^\circ C$, $f = 800\ Hz$		0.1 0.2	0.2 0.3	dB dB
I_{off}	Inhibit current consumption (pin 2)			0.3	1	mA
G	Amplifier gain	Inhibit ON (pin 2 grounded) $f = 800\ Hz$	-1.5	0	+1.5	dB

TEST AND APPLICATION CIRCUITS

Fig. 1 - Expander circuit

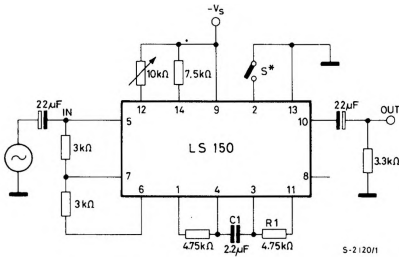

(*) S closed : unity gain amplifier.
S open : expander.

Fig. 2 - Compressor circuit

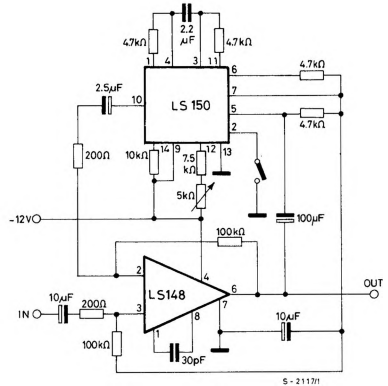

Fig. 3 - Compressor Characteristics

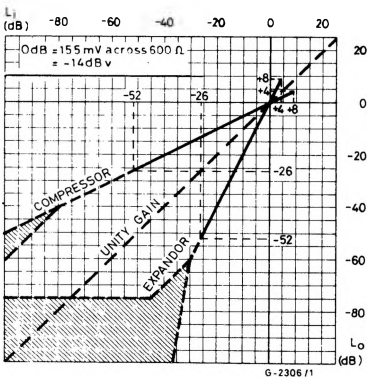

Fig. 4 - Comparison between LS150 performance (curve A) and limits from CCITT recommendation (curve B) - Green Book - Geneva 1972 - G162.

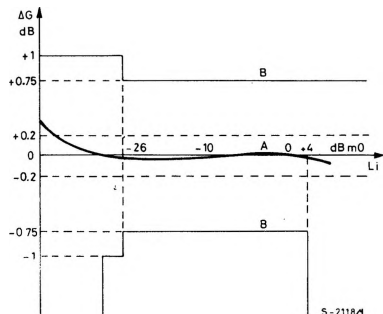

Fig. 5 - Expander gain vs. temperature

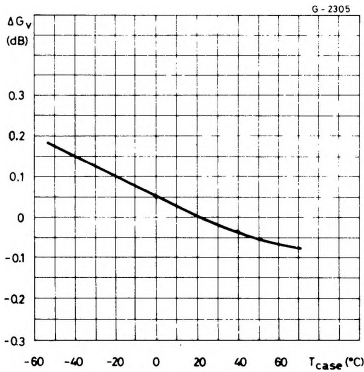
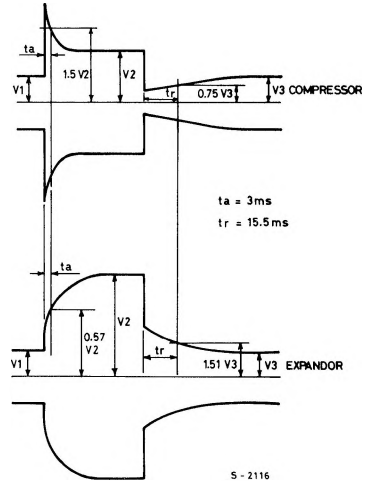

Fig. 6 - Transient response



APPLICATION INFORMATION

The fig. 7 shows the basic configuration (with relative signal levels) of a compandorized system. It is clear the action against the line noise: the system using a compressor in sending and an expander in receiving can improve very much the signal-to-noise ratio, especially with very high noise lines. By using the LS150 it is possible to built both the compressor and the expander blocks.

Fig. 7 - Compandorized system.

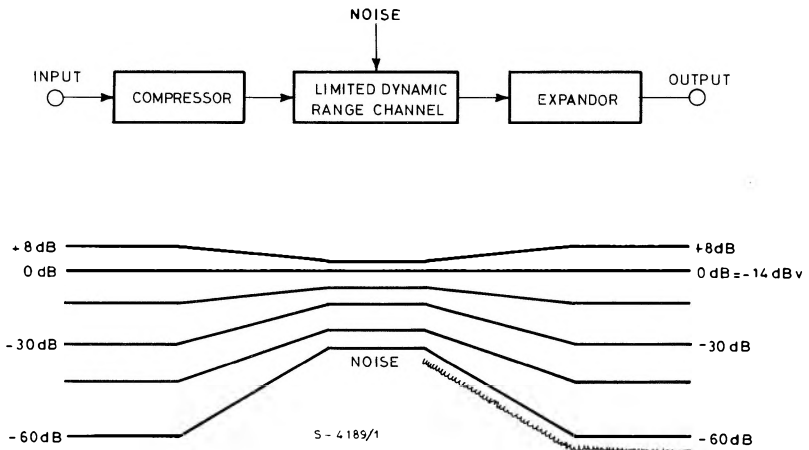

APPLICATION INFORMATION (continued)

The basic block diagram of an expander is shown in fig. 8. The product of the input voltage V_i and its mean value \bar{V}_i (obtained from the rectifier with time constant τ) is supplied at the output of an "ideal" multiplier.

Fig. 8 - Basic expander circuit.

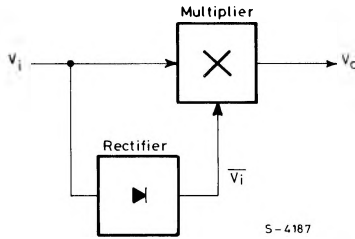

S-4187

The output voltage V_o is proportional to the product of V_i and \bar{V}_i :

$$V_o = KV_i \times \bar{V}_i$$

where K is a factor that defines a level for unity gain.

For a constant input level,

$$\bar{V}_o = K\bar{V}_i \times \bar{V}_i = K\bar{V}_i^2$$

Expressing all levels in decibels relative to a reference level:

$$\bar{V}_o \text{ (dB)} = 20 \log_{10} \bar{V}_i^2 = 2 \bar{V}_i \text{ (dB)}.$$

Signals with an input level equal to the reference level are unaffected by the expander while higher levels are raised and lower levels attenuated. It is recommended by CCITT, and practically advantageous, that the unaffected level be -14 dBv, a voltage corresponding to -14 dBm across 600Ω . A time constant for the average rectifier of 20 ms is also recommended, giving "syllabic" operation of the compressor.

Fig. 9 - Basic compressor circuit.

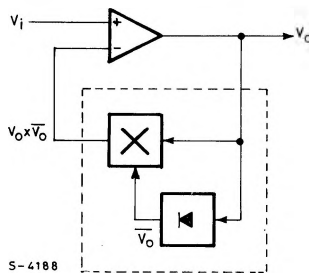

S-4188

A compressor can easily be implemented with an expander in the feedback path of an operational amplifier (Fig. 9). Assuming infinite gain for the amplifier:

$$V_i = KV_o \times \bar{V}_o$$

and for a constant input level

$$\bar{V}_o = \sqrt{\frac{V_i}{K}}$$

In decibels, with respect to the unaffected level,

$$\bar{V}_o \text{ (dB)} = 20 \log_{10} (\bar{V}_i)^{1/2} = \frac{1}{2} \bar{V}_i \text{ (dB)}.$$

**LS 150**

APPLICATION INFORMATION (continued)

Design Constraints

There are several constraints on the design of a compandor to be used in telecommunication equipment.

Level: The reference (or unity gain) level is -14 dBv, i.e. 155 mV rms. For application in high-quality multiplexer transmission systems between exchanges, and expansion accuracy better than 0.2 dB in the same range (+40 to -25 dBmo) considered by CCITT for all operating conditions is required. These parameters had to be compatible with mass production manufacturing techniques. Particularly when taking into account the low signal levels, this requirement is very demanding. It was the main target in designing the device and had a strong influence on the fabrication process, circuit configurations, and layout.

Power Supply: The circuit has to operate with a single 12V negative supply, unregulated, and with relatively high noise.

Input Impedance: This has to be precisely defined by an external resistor, which is the passive termination of an LC filter before the expander. Thus the input impedance of the IC must be very high. A differential input stage is preferable to reduce ground loop noise.

Gain: The expander (or compressor) shall not modify the level diagram of existing channel modems, already optimized for crosstalk and noise. This means that the gain at the unaffected level shall be 0 dB, with small spread.

Inhibition: It must be possible to inhibit the operation of the compandor for testing and maintenance purpose, and to allow the transmission of telegraph channels.

Definition of units

dBmo : power level $(10 \log \frac{P_2}{P_1})$ is expressed in dBm when P_1 is 1 mW, therefore 0 dBm = 1 mW.

dBm : the power is expressed in dBmo when referred to an established power level in the circuit, generally the output signal level.

e.g.: if the output level is -15 dBm and this level is chosen as reference, then 0 dBmo = -15 dBm; if another signal, i.e. the distortion measured at the same point of the circuit, is -90 dBm, then the distortion is -75 dBmo.

dBv : $20 \log \frac{V_2}{V_1}$ when $V_1 = 775$ mVrms.
