



# LP2950/A-XX and LP2951/A-XX Series of Adjustable Micropower Voltage Regulators

## General Description

The LP2950 and LP2951 are micropower voltage regulators with very low quiescent current (75  $\mu$ A typ.) and very low dropout voltage (typ. 40 mV at light loads and 380 mV at 100 mA). They are ideally suited for use in battery-powered systems. Furthermore, the quiescent current of the LP2950/LP2951 increases only slightly in dropout, prolonging battery life.

The LP2950-5.0 in the popular 3-pin TO-92 package is pin-compatible with older 5V regulators. The 8-lead LP2951 is available in plastic, ceramic dual-in-line, or metal can packages and offers additional system functions.

One such feature is an error flag output which warns of a low output voltage, often due to falling batteries on the input. It may be used for a power-on reset. A second feature is the logic-compatible shutdown input which enables the regulator to be switched on and off. Also, the part may be pin-strapped for a 5V, 3V, or 3.3V output (depending on the version), or programmed from 1.24V to 29V with an external pair of resistors.

Careful design of the LP2950/LP2951 has minimized all contributions to the error budget. This includes a tight initial

tolerance (.5% typ.), extremely good load and line regulation (.05% typ.) and a very low output voltage temperature coefficient, making the part useful as a low-power voltage reference.

## Features

- 5V, 3V, and 3.3V versions available
- High accuracy output voltage
- Guaranteed 100 mA output current
- Extremely low quiescent current
- Low dropout voltage
- Extremely tight load and line regulation
- Very low temperature coefficient
- Use as Regulator or Reference
- Needs minimum capacitance for stability
- Current and Thermal Limiting

## LP2951 versions only

- Error flag warns of output dropout
- Logic-controlled electronic shutdown
- Output programmable from 1.24 to 29V

## Block Diagram and Typical Applications

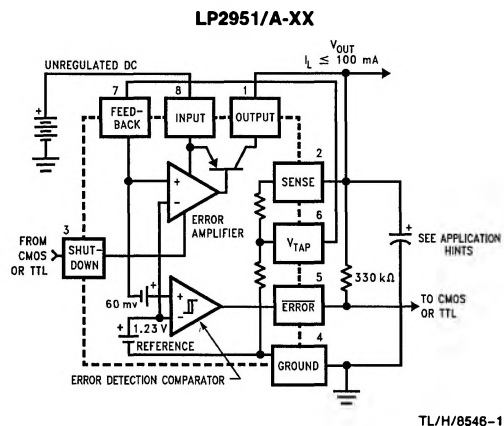
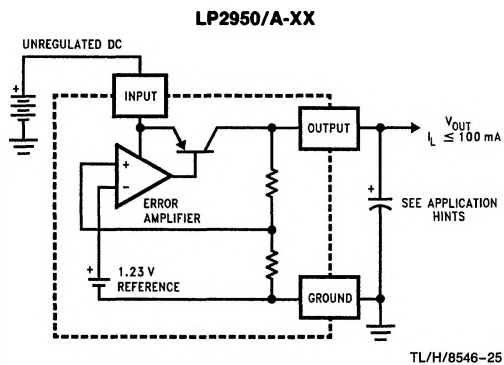

# Connection Diagrams

**TO-92 Plastic Package (Z)**

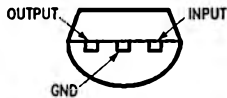

**Bottom View**

TL/H/8546-2

**Order Number LP2950ACZ-3.0, LP2950CZ-3.0, LP2950ACZ-3.3, LP2950CZ-3.3 LP2950ACZ-5.0 or LP2950CZ-5.0**

**See NS Package Number Z03A**

**Dual-In-Line Packages (N, J)  
Surface-Mount Package (M)**

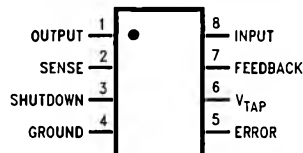

**Top View**

TL/H/8546-26

**Order Number LP2951CJ, LP2951ACJ, LP2951J, LP2951J/883 or 5962-3870501MPA**  
**See NS Package Number J08A**

**Order Number LP2951ACN, LP2951CN, LP2951ACN-3.0, LP2951CN-3.0, LP2951ACN-3.3 or LP2951CN-3.3**  
**See NS Package Number N08E**

**Order Number LP2951ACM, LP2951CM, LP2951ACM-3.0, LP2951CM-3.0, LP2951ACM-3.3 or LP2951CM-3.3**  
**See NS Package Number M08A**

**Metal Can Package (H)**

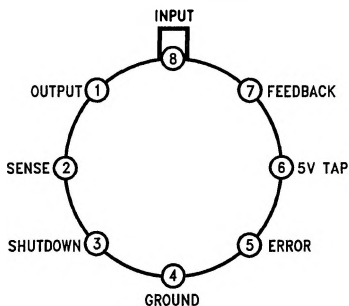

**Top View**

TL/H/8546-19

**Order Number LP2951H/883 or 5962-3870501MGA**  
**See NS Package Number H08C**

**Leadless Chip Carrier (E)**

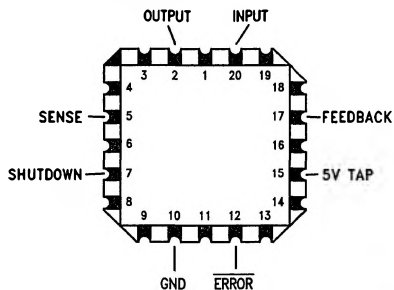

**Top View**

TL/H/8546-24

**Order Number LP2951E/883 or 5962-3870501M2A**  
**See NS Package Number E20A**

## Ordering Information

Package	Output Voltage			Temperature (°C)
	3.0V	3.3V	5.0V	
TO-92 (Z)	LP2950ACZ-3.0 LP2950CA-3.0	LP2950ACZ-3.3 LP2950CZ-3.3	LP2950ACZ-5.0 LP2950CZ-5.0	-40 < T <sub>J</sub> < 125
N (N-08E)	LP2951ACN-3.0 LP2951CN-3.0	LP2951ACN-3.3 LP2951CN-3.3	LP2951ACN LP2950CN	-40 < T <sub>J</sub> < 125
M (M08A)	LP2951ACM-3.0 LP2951CM-3.0	LP2951ACM-3.3 LP2951CM-3.3	LP2951ACM LP2951CM	-40 < T <sub>J</sub> < 125
J (J08A)			LP2951ACJ LP2951CJ  LP2951J LP2951J/883 5926-3870501MPA	-40 < T <sub>J</sub> < 125  -55 < T <sub>J</sub> < 150
H (H08C)			LP2951H/883 5962-3870501MGA	-55 < T <sub>J</sub> < 150
E (E20A)			LP2951E/883 5962-3870501M2A	-55 < T <sub>J</sub> < 150

## Absolute Maximum Ratings

If Military/Aerospace specified devices are required, please contact the National Semiconductor Sales Office/Distributors for availability and specifications.

Power Dissipation	Internally Limited
Lead Temp. (Soldering, 5 seconds)	260°C
Storage Temperature Range	-65° to +150°C
Operating Junction Temperature Range (Note 8)	
LP2951	-55° to +150°C
LP2950AC-XX, LP2950C-XX,	
LP2951AC-XX, LP2951C-XX	-40° to +125°C

Input Supply Voltage	-0.3 to +30V
Feedback Input Voltage (Notes 9 and 10)	-1.5 to +30V
Shutdown Input Voltage (Note 9)	-0.3 to +30V
Error Comparator Output Voltage (Note 9)	-0.3 to +30V
ESD Rating is to be determined.	

## Electrical Characteristics (Note 1)

Parameter	Conditions (Note 2)	LP2951		LP2950AC-XX LP2951AC-XX			LP2950C-XX LP2951C-XX			Units
		Typ	Tested Limit (Notes 3, 16)	Typ	Tested Limit (Note 3)	Design Limit (Note 4)	Typ	Tested Limit (Note 3)	Design Limit (Note 4)	
<b>3V VERSIONS (Note 17)</b>										
Output Voltage	$T_J = 25^\circ\text{C}$	3.0	3.015 2.985	3.0	3.015 2.985		3.0	3.030 2.970		V max V min
	$-25^\circ\text{C} \leq T_J \leq 85^\circ\text{C}$	3.0		3.0		3.030 2.970	3.0		3.045 2.955	V max V min
	Full Operating Temperature Range	3.0	<b>3.036</b> <b>2.964</b>	3.0		<b>3.036</b> <b>2.964</b>	3.0		<b>3.060</b> <b>2.940</b>	V max V min
Output Voltage	$100 \mu\text{A} \leq I_L \leq 100 \text{ mA}$ $T_J \leq T_{J\text{MAX}}$	3.0	<b>3.045</b> <b>2.955</b>	3.0		<b>3.042</b> <b>2.958</b>	3.0		<b>3.072</b> <b>2.928</b>	V max V min
<b>3.3V VERSIONS (Note 17)</b>										
Output Voltage	$T_J = 25^\circ\text{C}$	3.3	3.317 3.284	3.3	3.317 3.284		3.3	3.333 3.267		V max V min
	$-25^\circ\text{C} \leq T_J \leq 85^\circ\text{C}$	3.3		3.3		3.333 3.267	3.3		3.350 3.251	V max V min
	Full Operating Temperature Range	3.3	<b>3.340</b> <b>3.260</b>	3.3		<b>3.340</b> <b>3.260</b>	3.3		<b>3.366</b> <b>3.234</b>	V max V min
Output Voltage	$100 \mu\text{A} \leq I_L \leq 100 \text{ mA}$ $T_J \leq T_{J\text{MAX}}$	3.3	<b>3.350</b> <b>3.251</b>	3.3		<b>3.346</b> <b>3.254</b>	3.3		<b>3.379</b> <b>3.221</b>	V max V min
<b>5V VERSIONS (Note 17)</b>										
Output Voltage	$T_J = 25^\circ\text{C}$	5.0	5.025 4.975	5.0	5.025 4.975		5.0	5.05 4.95		V max V min
	$-25^\circ\text{C} \leq T_J \leq 85^\circ\text{C}$	5.0		5.0		5.05 4.95	5.0		5.075 4.925	V max V min
	Full Operating Temperature Range	5.0	<b>5.06</b> <b>4.94</b>	5.0		<b>5.06</b> <b>4.94</b>	5.0		<b>5.1</b> <b>4.9</b>	V max V min
Output Voltage	$100 \mu\text{A} \leq I_L \leq 100 \text{ mA}$ $T_J \leq T_{J\text{MAX}}$	5.0	<b>5.075</b> <b>4.925</b>	5.0		<b>5.075</b> <b>4.925</b>	5.0		<b>5.12</b> <b>4.88</b>	V max V min
<b>ALL VOLTAGE OPTIONS</b>										
Output Voltage Temperature Coefficient	(Note 12)	<b>20</b>	<b>120</b>	<b>20</b>		<b>100</b>	<b>50</b>		<b>150</b>	ppm/°C
Line Regulation (Note 14)	$(V_{O\text{NOM}} + 1)V \leq V_{\text{in}} \leq 30V$ (Note 15)	0.03	0.1 <b>0.5</b>	0.03	0.1		0.04	0.2		% max % max
Load Regulation (Note 14)	$100 \mu\text{A} \leq I_L \leq 100 \text{ mA}$	0.04	0.1 <b>0.3</b>	0.04	0.1		0.1	0.2		% max % max

**Electrical Characteristics** (Note 1) (Continued)

Parameter	Conditions (Note 2)	LP2951		LP2950AC-XX LP2951AC-XX			LP2950C-XX LP2951C-XX			Units
		Typ	Tested Limit (Notes 3, 16)	Typ	Tested Limit (Note 3)	Design Limit (Note 4)	Typ	Tested Limit (Note 3)	Design Limit (Note 4)	
<b>ALL VOLTAGE OPTIONS (Continued)</b>										
Dropout Voltage (Note 5)	$I_L = 100 \mu A$	50	80 <b>150</b>	50	80	<b>150</b>	50	80	<b>150</b>	mV max mV max
	$I_L = 100 mA$	380	450 <b>600</b>	380	450	<b>600</b>	380	450	<b>600</b>	mV max mV max
Ground Current	$I_L = 100 \mu A$	75	120 <b>140</b>	75	120	<b>140</b>	75	120	<b>140</b>	$\mu A$ max $\mu A$ max
	$I_L = 100 mA$	8	12 <b>14</b>	8	12	<b>14</b>	8	12	<b>14</b>	mA max mA max
Dropout Ground Current	$V_{in} = (V_{O(NOM)} - 0.5)V$ $I_L = 100 \mu A$	110	170 <b>200</b>	110	170	<b>200</b>	110	170	<b>200</b>	$\mu A$ max $\mu A$ max
Current Limit	$V_{out} = 0$	160	200 <b>220</b>	160	200	<b>220</b>	160	200	<b>220</b>	mA max mA max
Thermal Regulation	(Note 13)	0.05	0.2	0.05	0.2		0.05	0.2		%/W max
Output Noise, 10 Hz to 100 KHz	$C_L = 1 \mu F$ (5V Only)	430		430			430			$\mu V$ rms
	$C_L = 200 \mu F$	160		160			160			$\mu V$ rms
	$C_L = 3.3 \mu F$ (Bypass = 0.01 $\mu F$ Pins 7 to 1 (LP2951))	100		100			100			$\mu V$ rms
<b>8-PIN VERSIONS ONLY</b>		<b>LP2951</b>		<b>LP2951AC-XX</b>			<b>LP2951C-XX</b>			
Reference Voltage		1.235	1.25 <b>1.26</b> 1.22 <b>1.2</b>	1.235	1.25 1.22	<b>1.26</b> <b>1.2</b>	1.235	1.26 1.21	<b>1.27</b> <b>1.2</b>	V max V max V min V min
Reference Voltage	(Note 7)		<b>1.27</b> <b>1.19</b>			<b>1.27</b> <b>1.19</b>			<b>1.285</b> <b>1.185</b>	V max V min
Feedback Pin Bias Current		20	40 <b>60</b>	20	40	<b>60</b>	20	40	<b>60</b>	nA max nA max
Reference Voltage Temperature Coefficient	(Note 12)	20		20			50			ppm/°C
Feedback Pin Bias Current Temperature Coefficient		0.1		0.1			0.1			nA/°C
<b>Error Comparator</b>										
Output Leakage Current	$V_{OH} = 30V$	0.01	1 <b>2</b>	0.01	1	<b>2</b>	0.01	1	<b>2</b>	$\mu A$ max $\mu A$ max
Output Low Voltage	$V_{in} = (V_{O(NOM)} - 0.5)V$ $I_{OL} = 400 \mu A$	150	250 <b>400</b>	150	250	<b>400</b>	150	250	<b>400</b>	mV max mV max
Upper Threshold Voltage	(Note 6)	60	40 <b>25</b>	60	40	<b>25</b>	60	40	<b>25</b>	mV min mV min
Lower Threshold Voltage	(Note 6)	75	95 <b>140</b>	75	95	<b>140</b>	75	95	<b>140</b>	mV max mV max
Hysteresis	(Note 6)	15		15			15			mV

## Electrical Characteristics (Note 1) (Continued)

Parameter	Conditions (Note 2)	LP2951		LP2951AC-XX			LP2951C-XX			Units
		Typ	Tested Limit (Notes 3, 16)	Typ	Tested Limit (Note 3)	Design Limit (Note 4)	Typ	Tested Limit (Note 3)	Design Limit (Note 4)	
<b>8-PIN VERSIONS ONLY (Continued)</b>										
<b>Shutdown Input</b>										
Input Logic Voltage	Low (Regulator ON) High (Regulator OFF)	1.3	<b>0.6</b> <b>2.0</b>	1.3		<b>0.7</b> <b>2.0</b>	1.3		<b>0.7</b> <b>2.0</b>	V V max V min
Shutdown Pin Input Current	$V_{\text{shutdown}} = 2.4\text{V}$	30	50 <b>100</b>	30	50	<b>100</b>	30	50	<b>100</b>	$\mu\text{A max}$ $\mu\text{A max}$
	$V_{\text{shutdown}} = 30\text{V}$	450	600 <b>750</b>	450	600	<b>750</b>	450	600	<b>750</b>	$\mu\text{A max}$ $\mu\text{A max}$
Regulator Output Current in Shutdown	(Note 11)	3	10 <b>20</b>	3	10	<b>20</b>	3	10	<b>20</b>	$\mu\text{A max}$ $\mu\text{A max}$

**Note 1:** Boldface limits apply at temperature extremes.

**Note 2:** Unless otherwise specified all limits guaranteed for  $T_J = 25^\circ\text{C}$ ,  $V_{\text{in}} = (V_{\text{O}}\text{NOM} + 1)\text{V}$ ,  $I_L = 100 \mu\text{A}$  and  $C_L = 1 \mu\text{F}$  for 5V versions, and 2.2  $\mu\text{F}$  for 3V and 3.3V versions. Additional conditions for the 8-pin versions are Feedback tied to  $V_{\text{TAP}}$ , Output tied to Output Sense and  $V_{\text{shutdown}} \leq 0.8\text{V}$ .

**Note 3:** Guaranteed and 100% production tested.

**Note 4:** Guaranteed but not 100% production tested. These limits are not used to calculate outgoing AQL levels.

**Note 5:** Dropout Voltage is defined as the input to output differential at which the output voltage drops 100 mV below its nominal value measured at 1V differential. At very low values of programmed output voltage, the minimum input supply voltage of 2V (2.3V over temperature) must be taken into account.

**Note 6:** Comparator thresholds are expressed in terms of a voltage differential at the Feedback terminal below the nominal reference voltage measured at  $V_{\text{in}} = (V_{\text{O}}\text{NOM} + 1)\text{V}$ . To express these thresholds in terms of output voltage change, multiply by the error amplifier gain =  $V_{\text{out}}/V_{\text{ref}} = (R1 + R2)/R2$ . For example, at a programmed output voltage of 5V, the Error output is guaranteed to go low when the output drops by  $95 \text{ mV} \times 5\text{V}/1.235\text{V} = 384 \text{ mV}$ . Thresholds remain constant as a percent of  $V_{\text{out}}$  as  $V_{\text{out}}$  is varied, with the dropout warning occurring at typically 5% below nominal, 7.5% guaranteed.

**Note 7:**  $V_{\text{ref}} \leq V_{\text{out}} \leq (V_{\text{in}} - 1\text{V})$ ,  $2.3\text{V} \leq V_{\text{in}} \leq 30\text{V}$ ,  $100 \mu\text{A} \leq I_L \leq 100 \text{ mA}$ ,  $T_J \leq T_{\text{JMAX}}$ .

**Note 8:** The junction-to-ambient thermal resistance of the TO-92 package is  $180^\circ\text{C/W}$  with 0.4" leads and  $160^\circ\text{C/W}$  with 0.25" leads to a PC board. The thermal resistance of the 8-pin DIP packages is  $105^\circ\text{C/W}$  for the molded plastic (N) and  $130^\circ\text{C/W}$  for the cerdip (J) junction to ambient when soldered directly to a PC board. Thermal resistance for the metal can (H) is  $160^\circ\text{C/W}$  junction to ambient and  $20^\circ\text{C/W}$  junction to case. Junction to ambient thermal resistance for the S.O. (M) package is  $160^\circ\text{C/W}$ . Thermal resistance for the leadless chip carrier (E) package is  $95^\circ\text{C/W}$  junction to ambient and  $24^\circ\text{C/W}$  junction to case.

**Note 9:** May exceed input supply voltage.

**Note 10:** When used in dual-supply systems where the output terminal sees loads returned to a negative supply, the output voltage should be diode-clamped to ground.

**Note 11:**  $V_{\text{shutdown}} \geq 2\text{V}$ ,  $V_{\text{in}} \leq 30\text{V}$ ,  $V_{\text{out}} = 0$ , Feedback pin tied to  $V_{\text{TAP}}$ .

**Note 12:** Output or reference voltage temperature coefficient is defined as the worst case voltage change divided by the total temperature range.

**Note 13:** Thermal regulation is defined as the change in output voltage at a time T after a change in power dissipation is applied, excluding load or line regulation effects. Specifications are for a 50 mA load pulse at  $V_{\text{IN}} = 30\text{V}$  (1.25W pulse) for  $T = 10 \text{ ms}$ .

**Note 14:** Regulation is measured at constant junction temperature, using pulse testing with a low duty cycle. Changes in output voltage due to heating effects are covered under the specification for thermal regulation.

**Note 15:** Line regulation for the LP2951 is tested at  $150^\circ\text{C}$  for  $I_L = 1 \text{ mA}$ . For  $I_L = 100 \mu\text{A}$  and  $T_J = 125^\circ\text{C}$ , line regulation is guaranteed by design to 0.2%. See Typical Performance Characteristics for line regulation versus temperature and load current.

**Note 16:** A Military RETS spec is available on request. At time of printing, the LP2951 RETS spec complied with the boldface limits in this column. The LP2951H, E, or J may also be procured as Standard Military Drawing Spec #5962-3870501MGA, M2A, or MPA.

**Note 17:** All LP2950 devices have the nominal output voltage coded as the last two digits of the part number. In the LP2951 products, the 3.0V and 3.3V versions are designated by the last two digits, but the 5V version is denoted with no code at this location of the part number (refer to ordering information table).

# Typical Performance Characteristics

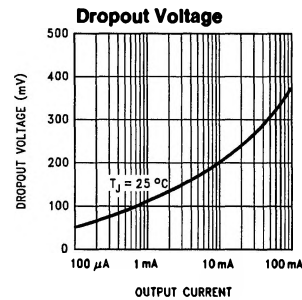
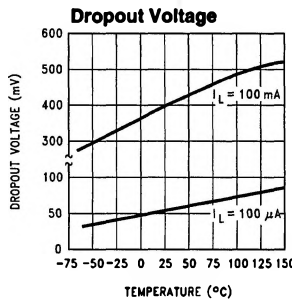
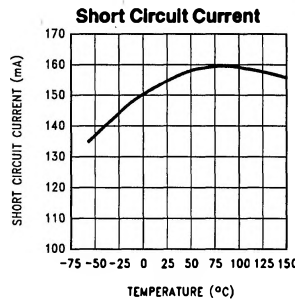
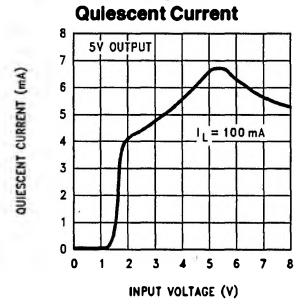
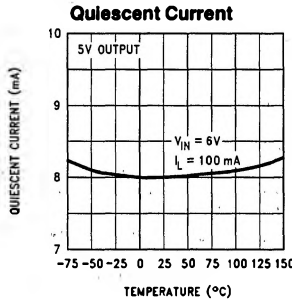
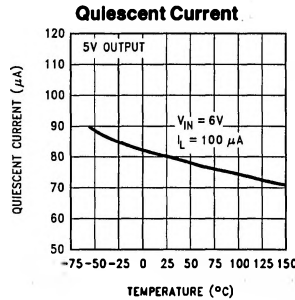
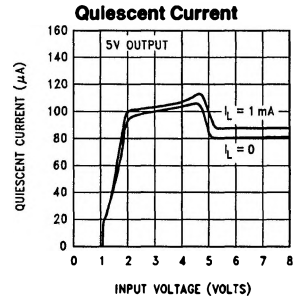
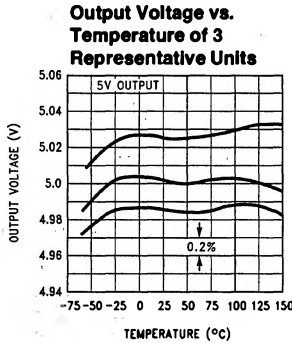
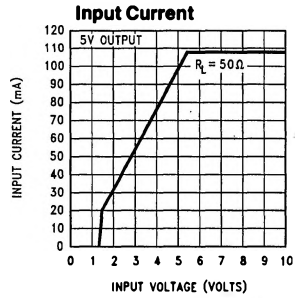
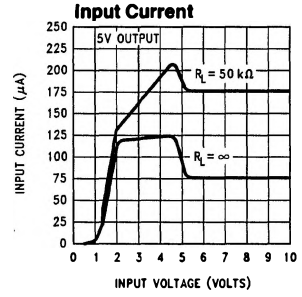
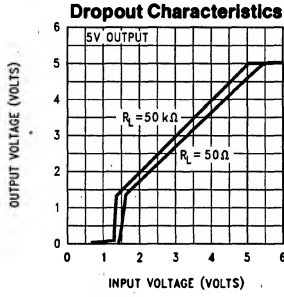
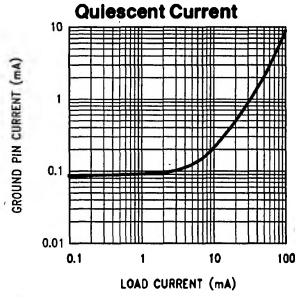

TL/H/8546-3

# Typical Performance Characteristics (Continued)

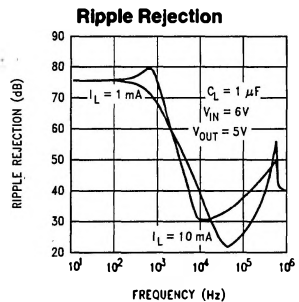
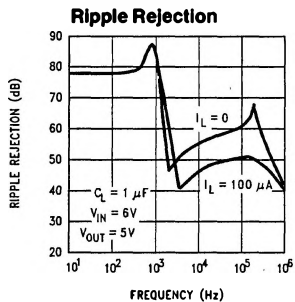
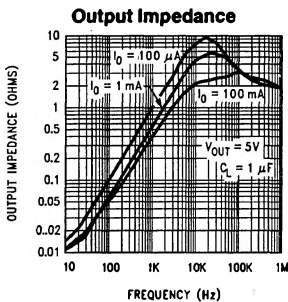
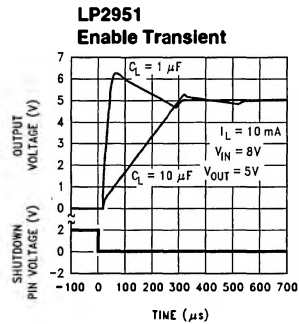
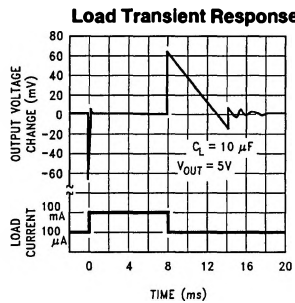
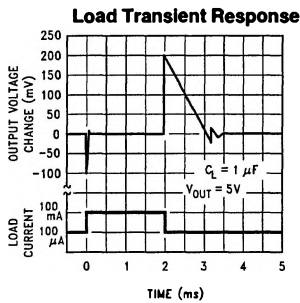
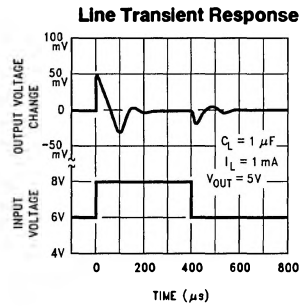
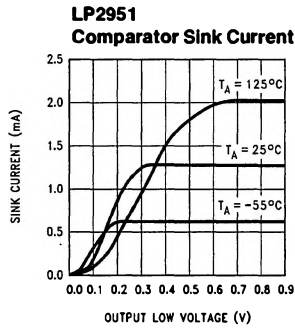
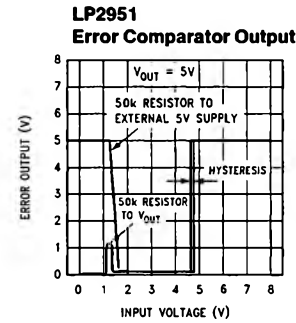
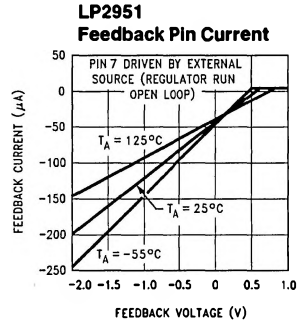
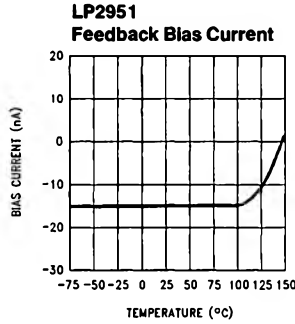
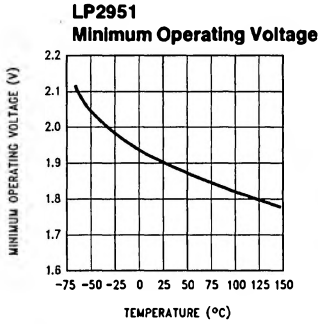

# Typical Performance Characteristics (Continued)

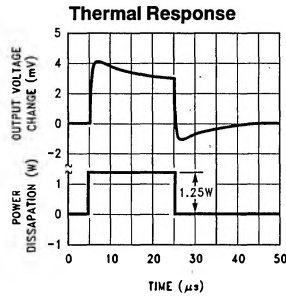
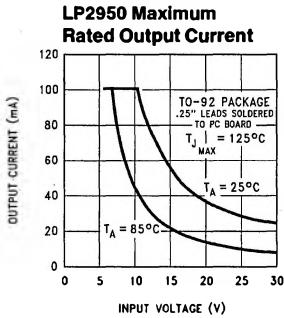
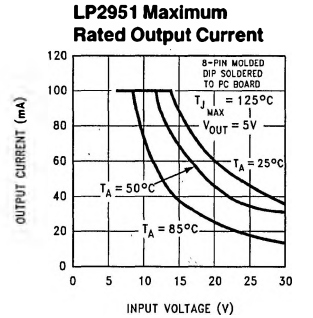
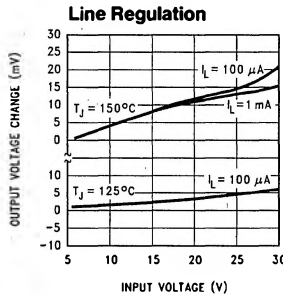
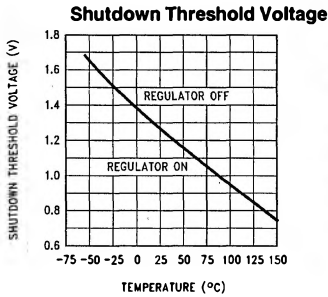
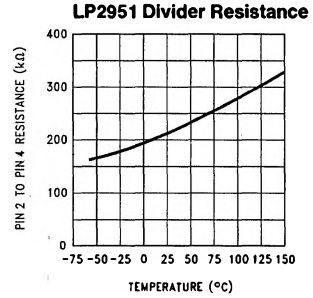
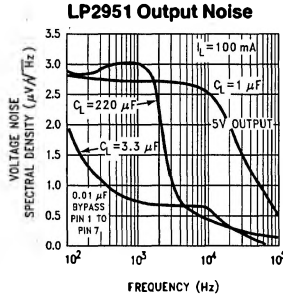
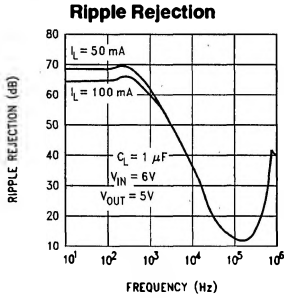

TL/H/8546-5

## Application Hints

### EXTERNAL CAPACITORS

A 1.0  $\mu\text{F}$  (or greater) capacitor is required between the output and ground for stability at output voltages of 5V or more. At lower output voltages, more capacitance is required (2.2  $\mu\text{F}$  or more is recommended for 3V and 3.3V versions). Without this capacitor the part will oscillate. Most types of tantalum or aluminum electrolytics work fine here; even film types work but are not recommended for reasons of cost. Many aluminum electrolytics have electrolytes that freeze at about  $-30^{\circ}\text{C}$ , so solid tantalums are recommended for operation below  $-25^{\circ}\text{C}$ . The important parameters of the capacitor are an ESR of about 5  $\Omega$  or less and a resonant frequency above 500 kHz. The value of this capacitor may be increased without limit.

At lower values of output current, less output capacitance is required for stability. The capacitor can be reduced to

0.33  $\mu\text{F}$  for currents below 10 mA or 0.1  $\mu\text{F}$  for currents below 1 mA. Using the adjustable versions at voltages below 5V runs the error amplifier at lower gains so that more output capacitance is needed. For the worst-case situation of a 100 mA load at 1.23V output (Output shorted to Feedback) a 3.3  $\mu\text{F}$  (or greater) capacitor should be used.

Unlike many other regulators, the LP2950 will remain stable and in regulation with no load in addition to the internal voltage divider. This is especially important in CMOS RAM keep-alive applications. When setting the output voltage of the LP2951 versions with external resistors, a minimum load of 1  $\mu\text{A}$  is recommended.

A 1  $\mu\text{F}$  tantalum or aluminum electrolytic capacitor should be placed from the LP2950/LP2951 input to ground if there is more than 10 inches of wire between the input and the AC filter capacitor or if a battery is used as the input.

## Application Hints (Continued)

Stray capacitance to the LP2951 Feedback terminal can cause instability. This may especially be a problem when using high value external resistors to set the output voltage. Adding a 100 pF capacitor between Output and Feedback and increasing the output capacitor to at least 3.3  $\mu$ F will fix this problem.

### ERROR DETECTION COMPARATOR OUTPUT

The comparator produces a logic low output whenever the LP2951 output falls out of regulation by more than approximately 5%. This figure is the comparator's built-in offset of about 60 mV divided by the 1.235 reference voltage. (Refer to the block diagram in the front of the datasheet.) This trip level remains "5% below normal" regardless of the programmed output voltage of the 2951. For example, the error flag trip level is typically 4.75V for a 5V output or 11.4V for a 12V output. The out of regulation condition may be due either to low input voltage, current limiting, or thermal limiting.

Figure 1 below gives a timing diagram depicting the ERROR signal and the regulated output voltage as the LP2951 input is ramped up and down. For 5V versions, the ERROR signal becomes valid (low) at about 1.3V input. It goes high at about 5V input (the input voltage at which  $V_{OUT} = 4.75$ ). Since the LP2951's dropout voltage is load-dependent (see curve in typical performance characteristics), the input voltage trip point (about 5V) will vary with the load current. The output voltage trip point (approx. 4.75V) does not vary with load.

The error comparator has an open-collector output which requires an external pullup resistor. This resistor may be returned to the output or some other supply voltage depending on system requirements. In determining a value for this resistor, note that while the output is rated to sink 400  $\mu$ A, this sink current adds to battery drain in a low battery condition. Suggested values range from 100k to 1 M $\Omega$ . The resistor is not required if this output is unused.

### PROGRAMMING THE OUTPUT VOLTAGE (LP2951)

The LP2951 may be pin-strapped for the nominal fixed output voltage using its internal voltage divider by tying the output and sense pins together, and also tying the feedback and  $V_{TAP}$  pins together. Alternatively, it may be programmed for any output voltage between its 1.235V reference and its 30V maximum rating. As seen in Figure 2, an external pair of resistors is required.

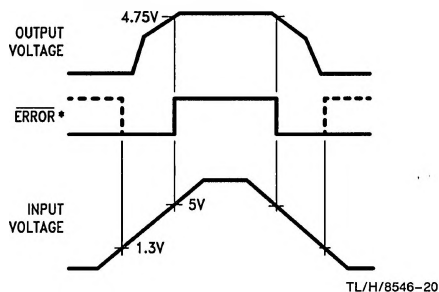

\*When  $V_{IN} \leq 1.3V$ , the error flag pin becomes a high impedance, and the error flag voltage rises to its pull-up voltage. Using  $V_{OUT}$  as the pull-up voltage (see Figure 2), rather than an external 5V source, will keep the error flag voltage under 1.2V (typ.) in this condition. The user may wish to divide down the error flag voltage using equal-value resistors (10 k $\Omega$  suggested), to ensure a low-level logic signal during any fault condition, while still allowing a valid high logic level during normal operation.

FIGURE 1. ERROR Output Timing

The complete equation for the output voltage is

$$V_{OUT} = V_{REF} \cdot \left( 1 + \frac{R_1}{R_2} \right) + I_{FB}R_1$$

where  $V_{REF}$  is the nominal 1.235 reference voltage and  $I_{FB}$  is the feedback pin bias current, nominally -20 nA. The minimum recommended load current of 1  $\mu$ A forces an upper limit of 1.2 M $\Omega$  on the value of  $R_2$ , if the regulator must work with no load (a condition often found in CMOS in standby).  $I_{FB}$  will produce a 2% typical error in  $V_{OUT}$  which may be eliminated at room temperature by trimming  $R_1$ . For better accuracy, choosing  $R_2 = 100k$  reduces this error to 0.17% while increasing the resistor program current to 12  $\mu$ A. Since the LP2951 typically draws 60  $\mu$ A at no load with Pin 2 open-circuited, this is a small price to pay.

### REDUCING OUTPUT NOISE

In reference applications it may be advantageous to reduce the AC noise present at the output. One method is to reduce the regulator bandwidth by increasing the size of the output capacitor. This is the only way noise can be reduced on the 3 lead LP2950 but is relatively inefficient, as increasing the capacitor from 1  $\mu$ F to 220  $\mu$ F only decreases the noise from 430  $\mu$ V to 160  $\mu$ V rms for a 100 kHz bandwidth at 5V output.

Noise can be reduced fourfold by a bypass capacitor across  $R_1$ , since it reduces the high frequency gain from 4 to unity. Pick

$$C_{BYPASS} \cong \frac{1}{2\pi R_1 \cdot 200 \text{ Hz}}$$

or about 0.01  $\mu$ F. When doing this, the output capacitor must be increased to 3.3  $\mu$ F to maintain stability. These changes reduce the output noise from 430  $\mu$ V to 100  $\mu$ V rms for a 100 kHz bandwidth at 5V output. With the bypass capacitor added, noise no longer scales with output voltage so that improvements are more dramatic at higher output voltages.

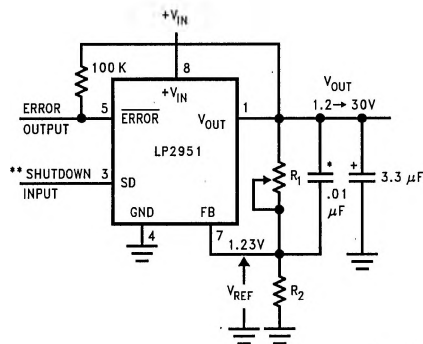

FIGURE 2. Adjustable Regulator

\*See Application Hints

$$V_{OUT} = V_{REF} \left( 1 + \frac{R_1}{R_2} \right)$$

\*\*Drive with TTL-high to shut down. Ground or leave open if shutdown feature is not to be used.

Note: Pins 2 and 6 are left open.

# Typical Applications

## 1A Regulator with 1.2V Dropout

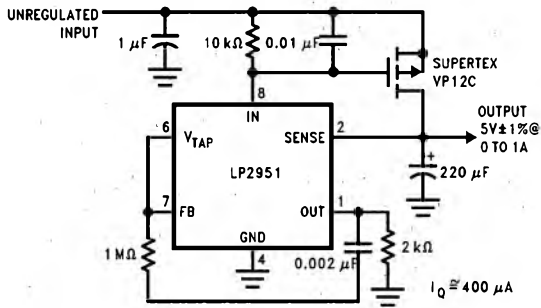

TL/H/8546-22

## 300 mA Regulator with 0.75V Dropout

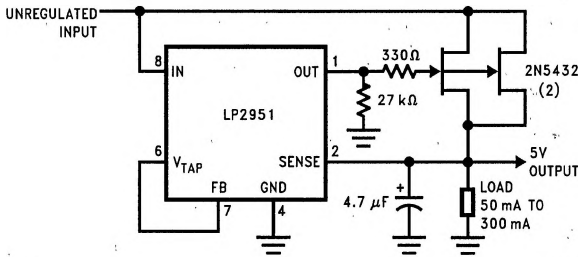

TL/H/8546-21

## Wide Input Voltage Range Current Limiter

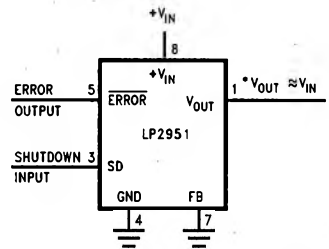

TL/H/8546-9

\*Minimum input-output voltage ranges from 40 mV to 400 mV, depending on load current. Current limit is typically 160 mA.

## Low Drift Current Source

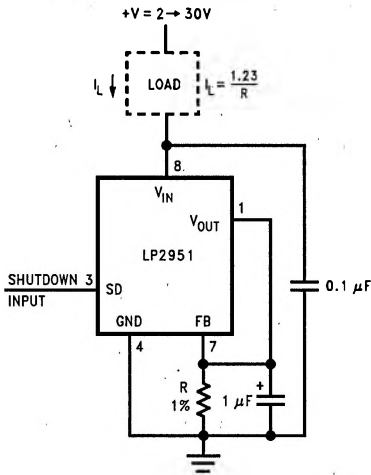

TL/H/8546-8

## 5 Volt Current Limiter

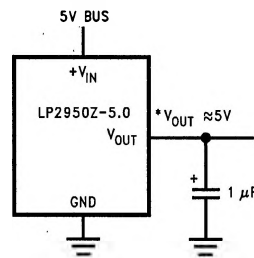

TL/H/8546-10

\*Minimum input-output voltage ranges from 40 mV to 400 mV, depending on load current. Current limit is typically 160 mA.

## Typical Applications (Continued)

### Regulator with Early Warning and Auxiliary Output

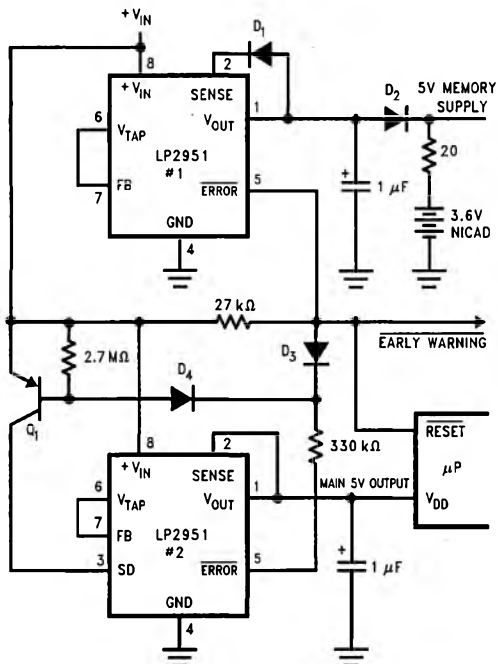

TL/H/8546-11

- Early warning flag on low input voltage
- Main output latches off at lower input voltages
- Battery backup on auxiliary output

Operation: Reg. #1's  $V_{OUT}$  is programmed one diode drop above 5V. Its error flag becomes active when  $V_{IN} \leq 5.7V$ . When  $V_{IN}$  drops below 5.3V, the error flag of Reg. #2 becomes active and via Q1 latches the main output off. When  $V_{IN}$  again exceeds 5.7V Reg. #1 is back in regulation and the early warning signal rises, unlatching Reg. #2 via D3.

### Latch Off When Error Flag Occurs

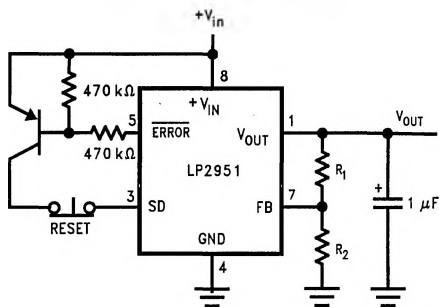

TL/H/8546-12

### 2 Ampere Low Dropout Regulator

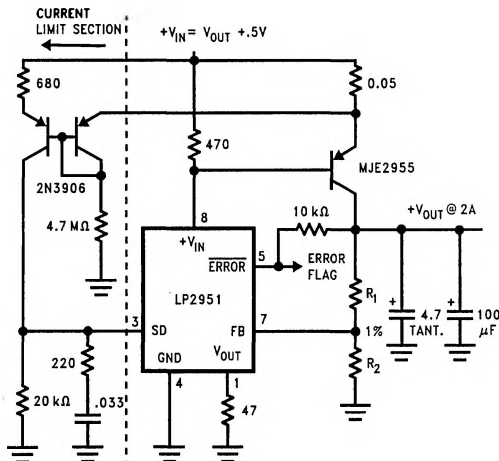

TL/H/8546-13

$$V_{OUT} = 1.23V \left( 1 + \frac{R_1}{R_2} \right)$$

For 5V<sub>OUT</sub>, use internal resistors. Wire pin 6 to 7, & wire pin 2 to +V<sub>OUT</sub> Buss.

### 5V Regulator with 2.5V Sleep Function

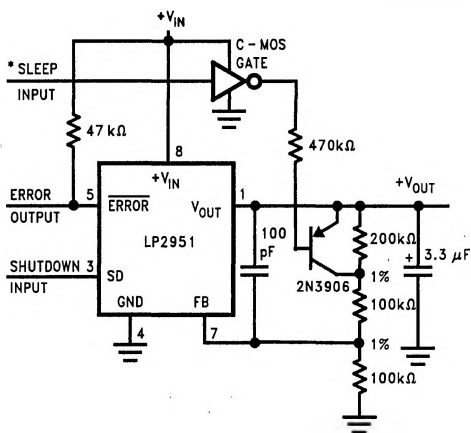

TL/H/8546-14

\*High input lowers  $V_{OUT}$  to 2.5V

### Open Circuit Detector for 4 → 20 mA Current Loop

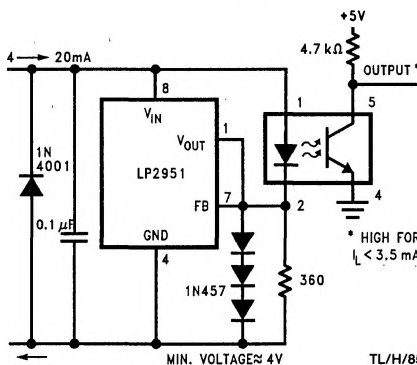

TL/H/8546-15

## Typical Applications (Continued)

### Regulator with State-of-Charge Indicator

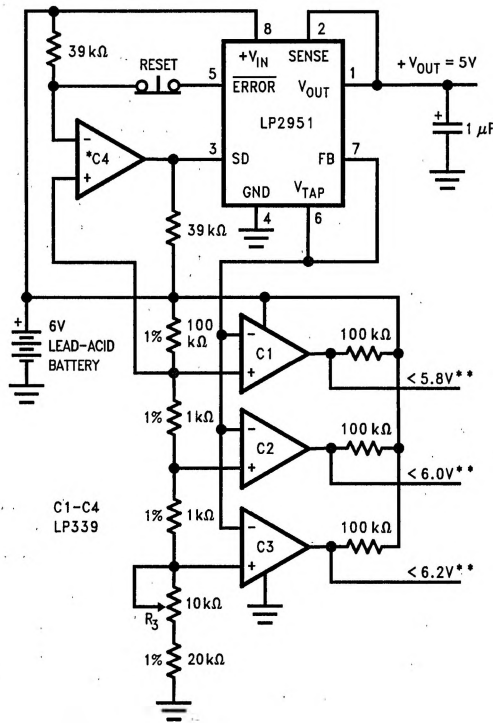

\*Optional Latch off when drop out occurs. Adjust R3 for C2 Switching when  $V_{in}$  is 6.0V.

\*\*Outputs go low when  $V_{in}$  drops below designated thresholds.

TL/H/8546-16

### Low Battery Disconnect

For values shown, Regulator shuts down when  $V_{in} < 5.5V$  and turns on again at 6.0V. Current drain in disconnected mode is  $\approx 150 \mu A$ .

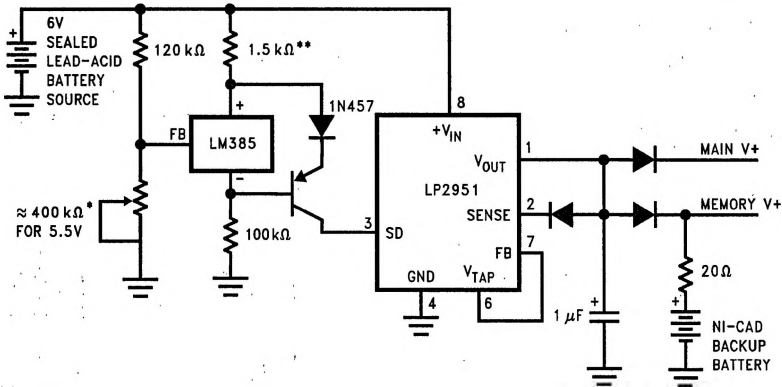

\*Sets disconnect Voltage

\*\*Sets disconnect Hysteresis

TL/H/8546-17

# Typical Applications (Continued)

## System Overtemperature Protection Circuit

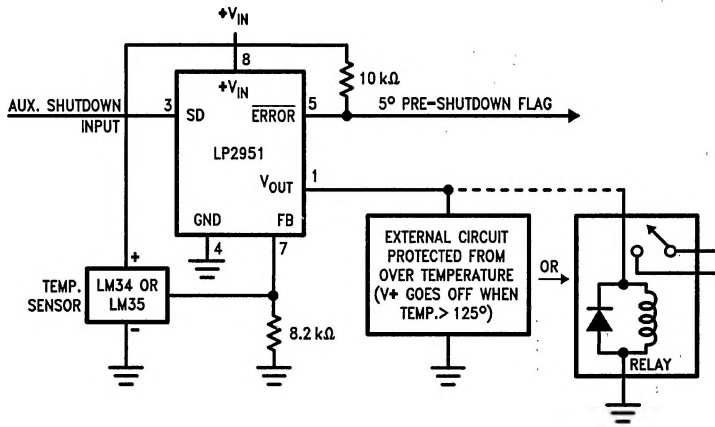

LM34 for 125°F Shutdown  
LM35 for 125°C Shutdown

TL/H/8546-18

# Schematic Diagram

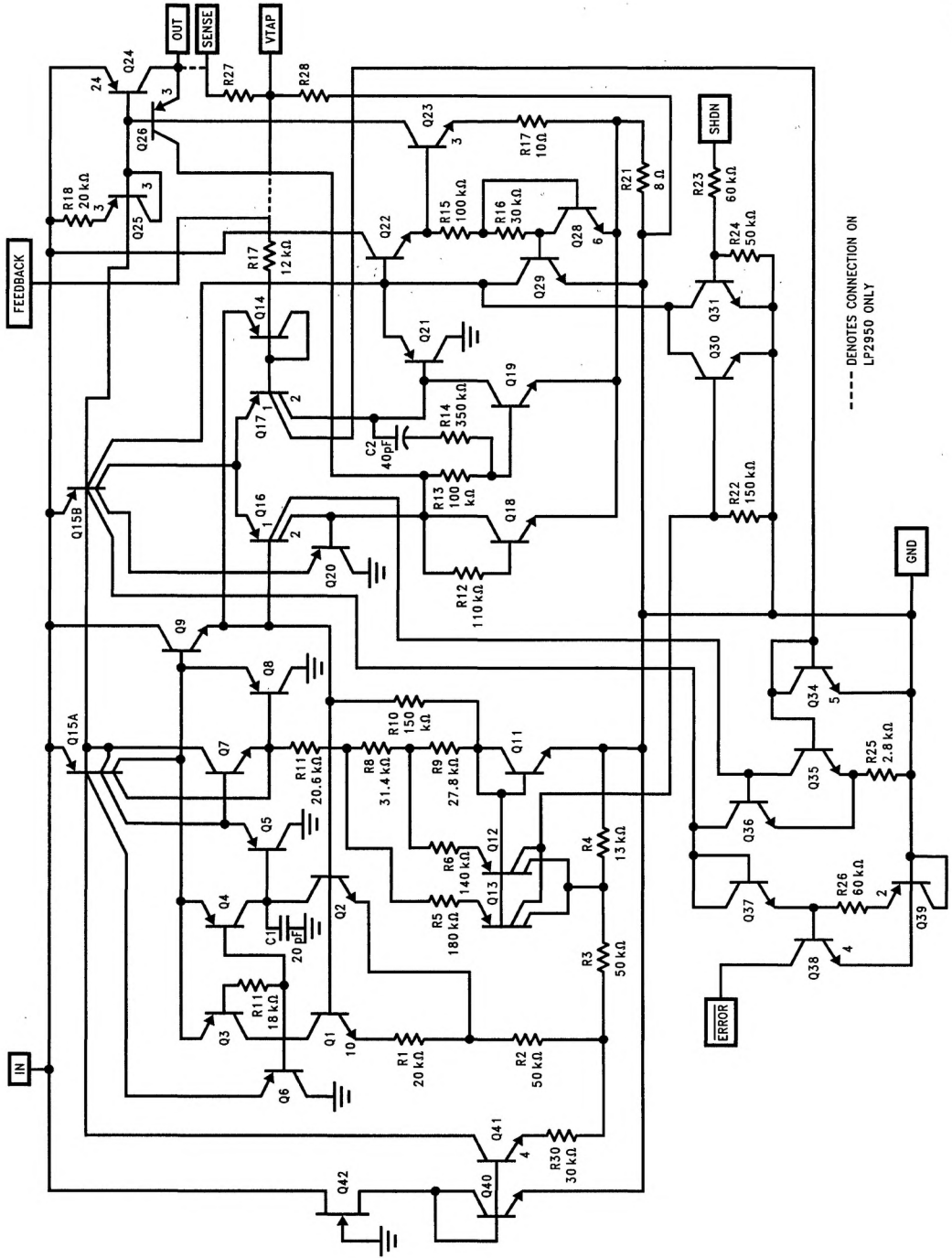

----- DENOTES CONNECTION ON  
LP2950 ONLY