



# LMC835 Digital Controlled Graphic Equalizer

## General Description

The LMC835 is a monolithic, digitally-controlled graphic equalizer CMOS LSI for Hi-Fi audio. The LMC835 consists of a Logic section and a Signal Path section made of analog switches and thin-film silicon-chromium resistor networks. The LMC835 is used with external resonator circuits to make a stereo equalizer with seven bands,  $\pm 12$  dB or  $\pm 6$  dB gain range and 25 steps each. Only three digital inputs are needed to control the equalization. The LMC835 makes it easy to build a  $\mu$ P-controlled equalizer.

The signal path is designed for very low noise and distortion, resulting in very high performance, compatible with PCM audio.

## Features

- No volume controls required
- Three-wire interface
- 14 bands, 25 steps each
- $\pm 12$  dB or  $\pm 6$  dB gain ranges
- Low noise and distortion
- TTL, CMOS logic compatible

## Applications

- Hi-Fi equalizer
- Receiver
- Car stereo
- Musical instrument
- Tape equalization
- Mixer
- Volume controller

## Connection Diagrams

Dual-In-Line Package

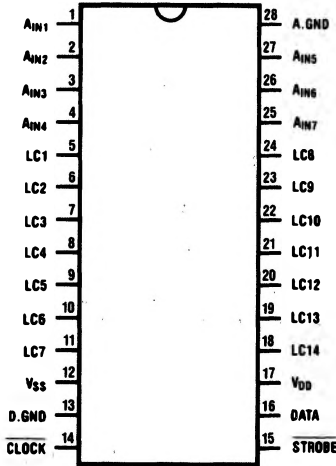

Top View

Order Number LMC835N  
See NS Package N28B

TL/H/6753-1

Molded Chip Carrier Package

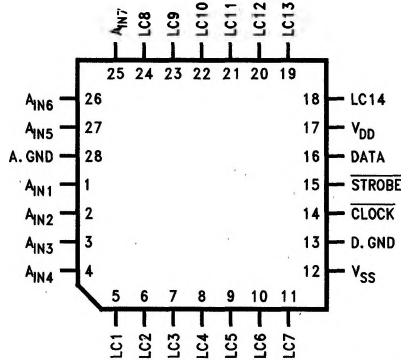

Top View

Order Number LMC835V  
See NS Package V28A

TL/H/6753-26

Block Diagram

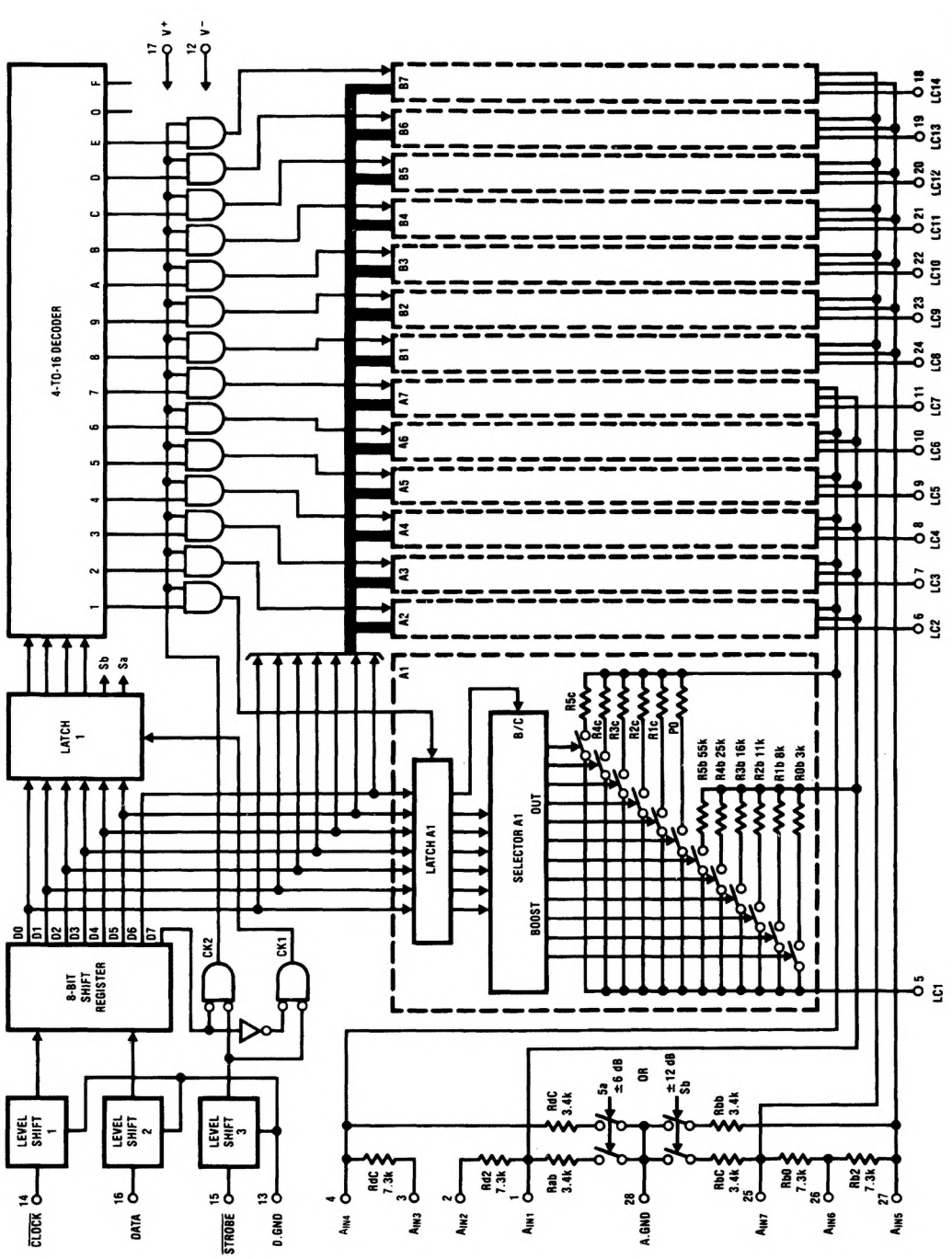

## Absolute Maximum Ratings

If Military/Aerospace specified devices are required, please contact the National Semiconductor Sales Office/Distributors for availability and specifications.

Supply Voltage, $V_{DD} - V_{SS}$	18V
Allowable Input Voltage (Note 1)	$V_{SS} - 0.3V$ to $V_{DD} + 0.3V$
Storage Temperature, $T_{stg}$	$-60^{\circ}C$ to $+150^{\circ}C$
Lead Temperature (Soldering, 10 sec), N Pkg	$+260^{\circ}C$
Lead Temperature, V Pkg	
Vapor Phase (60 sec)	$+215^{\circ}C$
Infrared (15 sec)	$+220^{\circ}C$

## Operating Ratings

Supply Voltage, $V_{DD} - V_{SS}$	5V to 16V
Digital Ground (Pin 13)	$V_{SS}$ to $V_{DD}$
Digital Input (Pins 14, 15, 16)	$V_{SS}$ to $V_{DD}$
Analog Input (Pins 1, 2, 3, 4, 25, 26, 27) (Note 1)	$V_{SS}$ to $V_{DD}$
Operating Temperature, $T_{opr}$	$-40^{\circ}C$ to $+85^{\circ}C$

## Electrical Characteristics (Note 2) $V_{DD} = 7.5V$ , $V_{SS} = -7.5V$ , A.GND = 0V

### LOGIC SECTION

Symbol	Parameter	Test Conditions	Typ	Tested Limit (Note 3)	Design Limit (Note 4)	Unit (Limit)
$I_{DDL}$	Supply Current	Pins 14, 15, 16 are 0V	0.01	0.5	<b>0.5</b>	mA (Max)
$I_{SSL}$		Pins 14, 15, 16 are 0V	0.01	0.5	<b>0.5</b>	mA (Max)
$I_{DDH}$		Pins 14, 15, 16 are 5V	1.3	5	<b>5</b>	mA (Max)
$I_{SSH}$		Pins 14, 15, 16 are 5V	0.9	5	<b>5</b>	mA (Max)
$V_{IH}$	High-Level Input Voltage	@Pins 14, 15, 16	1.8	2.3	<b>2.5</b>	V (Min)
$V_{IL}$	Low-Level Input Voltage	@Pins 14, 15, 16	0.9	0.6	<b>0.4</b>	V (Max)
$f_o$	Clock Frequency	@Pin 14	2000	500	<b>500</b>	kHz (Max)
$t_w(STB)$	Width of STB Input	See Figure 1	0.25	1	<b>1</b>	$\mu s$ (Min)
$t_{setup}$	Data Setup Time	See Figure 1	0.25	1	<b>1</b>	$\mu s$ (Min)
$t_{hold}$	Data Hold Time	See Figure 1	0.25	1	<b>1</b>	$\mu s$ (Min)
$t_{cs}$	Delay from Rising Edge of $\overline{CLOCK}$ to STB	See Figure 1	0.25	1	<b>1</b>	$\mu s$ (Min)
$I_{IN}$	Input Current	@Pins 14, 15, 16 $0V < V_{IN} < 5V$	$\pm 0.01$	$\pm 1$		$\mu A$ (Max)
$C_{IN}$	Input Capacitance	@Pins 14, 15, 16 $f = 1$ MHz	5			pF

Note 1: Pins 2, 3 and 26 have a maximum input voltage range of  $\pm 22V$  for the typical application shown in Figure 7.

Note 2: Bold numbers apply at temperature extremes. All other numbers apply at  $T_A = 25^{\circ}C$ ,  $V_{DD} = 7.5V$ ,  $V_{SS} = -7.5V$ , D.GND = A.GND = 0V as shown in the test circuit, Figures 3 and 4.

Note 3: Guaranteed and 100% production tested.

Note 4: Guaranteed (but not 100% production tested) over the operating temperature range. These limits are not used to calculate outgoing quality levels.

## Timing Diagram

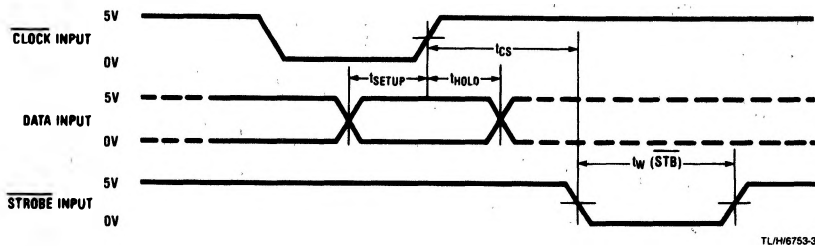

Note: To change the gain of the presently selected band, it is not necessary to send DATA 1 (Band Selection) each time.

FIGURE 1

## Electrical Characteristics (Note 2) $V_{DD} = 7.5V$ , $V_{SS} = -7.5V$ , $D.GND = A.GND = 0V$

### SIGNAL PATH SECTION

Symbol	Parameter	Test Conditions	Typ	Tested Limit (Note 3)	Design Limit (Note 4)	Unit (Limit)
EA	Gain Error	$A_V = 0 \text{ dB} @ \pm 12 \text{ dB Range}$	0.1	0.5	0.5	dB (Max)
		$A_V = 0 \text{ dB} @ \pm 6 \text{ dB Range}$	0.1	1	1	dB (Max)
		$A_V = \pm 1 \text{ dB} @ \pm \text{dB Range}$ ( $R_{5b}$ or $R_{5c}$ is ON)	0.1	0.5	0.6	dB (Max)
		$A_V = \pm 2 \text{ dB} @ \pm 12 \text{ dB Range}$ ( $R_{4b}$ or $R_{4c}$ is ON)	0.1	0.5	0.6	dB (Max)
		$A_V = \pm 3 \text{ dB} @ \pm 12 \text{ dB Range}$ ( $R_{3b}$ or $R_{3c}$ is ON)	0.1	0.5	0.6	dB (Max)
		$A_V = \pm 4 \text{ dB} @ \pm 12 \text{ dB Range}$ ( $R_{2b}$ or $R_{2c}$ is ON)	0.1	0.5	0.7	dB (Max)
		$A_V = \pm 5 \text{ dB} @ \pm 12 \text{ dB Range}$ ( $R_{1b}$ or $R_{1c}$ is ON)	0.1	0.5	0.7	dB (Max)
		$A_V = \pm 9 \text{ dB} @ \pm 12 \text{ dB Range}$ ( $R_{0b}$ or $R_{0c}$ is ON)	0.2	1	1.3	dB (Max)
THD	Total Harmonic Distortion	$A_V = 0 \text{ dB} @ \pm 12 \text{ dB Range}$ $V_{IN} = 4V_{rms}$ , $f = 1 \text{ kHz}$	0.0015			%
		$A_V = 12 \text{ dB} @ \pm 12 \text{ dB Range}$ $V_{IN} = 1V_{rms}$ , $f = 1 \text{ kHz}$	0.01	0.1		% (Max)
		$V_{IN} = 1V_{rms}$ , $f = 20 \text{ kHz}$	0.1	0.5		% (Max)
		$A_V = -12 \text{ dB} @ \pm 12 \text{ dB Range}$ $V_{IN} = 4V_{rms}$ , $f = 1 \text{ kHz}$	0.01	0.1		% (Max)
		$V_{IN} = 4V_{rms}$ , $f = 20 \text{ kHz}$	0.1	0.5		% (Max)
$V_{O \text{ Max}}$	Maximum Output Voltage	$A_V = 0 \text{ dB} @ \pm 12 \text{ dB Range}$ THD < 1%, $f = 1 \text{ kHz}$	5.5	5.1	5	$V_{rms}$ (Min)
S/N	Signal to Noise Ratio	$A_V = 0 \text{ dB} @ \pm 12 \text{ dB Range}$ $V_{ref} = 1 V_{rms}$	114			dB
		$A_V = 12 \text{ dB} @ \pm 12 \text{ dB Range}$ $V_{ref} = 1 V_{rms}$	106			dB
		$A_V = -12 \text{ dB} @ \pm 12 \text{ dB Range}$ $V_{ref} = 1 V_{rms}$	116			dB
$I_{LEAK}$	Leakage Current	$A_V = 0 \text{ dB} @ \pm 12 \text{ dB Range}$ (All internal switches are OFF) Pin 2 + 3, Pin 26 Pin 5 ~ Pin 11, Pin 18 ~ Pin 24		500 50		nA (Max) nA (Max)

**Note 2:** Boldface numbers apply at temperature extremes. All other numbers apply at  $T_A = 25^\circ\text{C}$ ,  $V_{DD} = 7.5V$ ,  $V_{SS} = -7.5V$ ,  $D.GND = A.GND = 0V$  as shown in the test circuit, Figures 3 and 4.

**Note 3:** Guaranteed and 100% production tested.

**Note 4:** Guaranteed (but not 100% production tested) over the operating temperature range. These limits are not used to calculate outgoing quality levels.

### Timing Diagrams

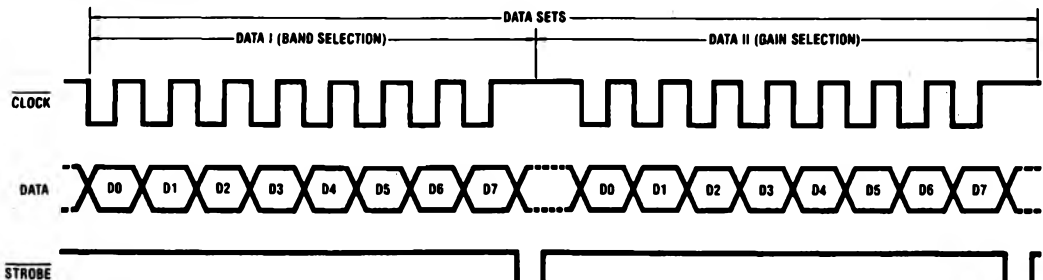

**Note:** To change the gain of the presently selected band, it is not necessary to send DATA 1 (Band Selection) each time.

FIGURE 2

TL/H/6753-4

# Truth Tables

**DATA I (Band Selection)**

D7	D6	D5	D4	D3	D2	D1	D0	
H	X	L	L	L	L	L	L	
H	X	L	L	L	L	L	H	
H	X	L	L	L	L	H	L	
H	X	L	L	L	L	H	H	
H	X	L	L	L	H	L	L	
H	X	L	L	L	H	L	H	
H	X	L	L	L	H	H	L	
H	X	L	L	L	H	H	H	
H	X	L	L	H	L	L	L	
H	X	L	L	H	L	L	H	
H	X	L	L	H	L	H	L	
H	X	L	L	H	L	H	H	
H	X	L	L	H	H	L	L	
H	X	L	L	H	H	L	H	
H	X	L	L	H	H	H	L	
H	X	L	L	H	H	H	H	
H	X	L	H	Valid Binary Input				
H	X	H	L	Valid Binary Input				
H	X	H	H	Valid Binary Input				
↑	↑	↑	↑	← Band Code →				
⓪	ⓑ	ⓒ	ⓓ					

(Ch A: Band 1~7, Ch B: Band 8~14)

- Ch A ± 12 dB Range, Ch B ± 12 dB Range, No Band Selection
- Ch A ± 12 dB Range, Ch B ± 12 dB Range, Band 1
- Ch A ± 12 dB Range, Ch B ± 12 dB Range, Band 2
- Ch A ± 12 dB Range, Ch B ± 12 dB Range, Band 3
- Ch A ± 12 dB Range, Ch B ± 12 dB Range, Band 4
- Ch A ± 12 dB Range, Ch B ± 12 dB Range, Band 5
- Ch A ± 12 dB Range, Ch B ± 12 dB Range, Band 6
- Ch A ± 12 dB Range, Ch B ± 12 dB Range, Band 7
- Ch A ± 12 dB Range, Ch B ± 12 dB Range, Band 8
- Ch A ± 12 dB Range, Ch B ± 12 dB Range, Band 9
- Ch A ± 12 dB Range, Ch B ± 12 dB Range, Band 10
- Ch A ± 12 dB Range, Ch B ± 12 dB Range, Band 11
- Ch A ± 12 dB Range, Ch B ± 12 dB Range, Band 12
- Ch A ± 12 dB Range, Ch B ± 12 dB Range, Band 13
- Ch A ± 12 dB Range, Ch B ± 12 dB Range, Band 14
- Ch A ± 12 dB Range, Ch B ± 12 dB Range, No Band Selection
- Ch A ± 12 dB Range, Ch B ± 6 dB Range, Band 1~14
- Ch A ± 6 dB Range, Ch B ± 12 dB Range, Band 1~14
- Ch A ± 6 dB Range, Ch B ± 6 dB Range, Band 1~14

- ⓪ DATA 1
- ⓑ Don't Care
- ⓒ Ch A ±6 dB/±12 dB Range
- ⓓ Ch B ±6 dB/±12 dB Range

This is the gain if the ±12 dB range is selected by DATA I. If the ±6 dB range is selected, then the values shown must be approximately halved. See the characteristics curves for more exact data.

**DATA II (Gain Selection)**

- Flat
- 1 dB Boost
- 2 dB Boost
- 3 dB Boost
- 4 dB Boost
- 5 dB Boost
- 6 dB Boost
- 7 dB Boost
- 8 dB Boost
- 9 dB Boost
- 10 dB Boost
- 11 dB Boost
- 12 dB Boost
- 1 dB~12 dB Cut

D7	D6	D5	D4	D3	D2	D1	D0	
L	X	L	L	L	L	L	L	
L	H	H	L	L	L	L	L	
L	H	L	H	L	L	L	L	
L	H	L	L	H	L	L	L	
L	H	L	L	L	H	L	L	
L	H	L	L	L	L	H	L	
L	H	L	H	L	L	H	L	
L	H	H	L	H	L	H	L	
L	H	L	H	L	H	H	L	
L	H	L	L	L	L	L	H	
L	H	H	L	H	L	L	H	
L	H	H	L	H	H	L	H	
L	H	H	L	H	H	H	H	
L	L	Valid Above Input						
↑	↑	← Gain Code →						
⓪	ⓑ							

- ⓪ DATA II
- ⓑ Boost/Cut

Test Circuits

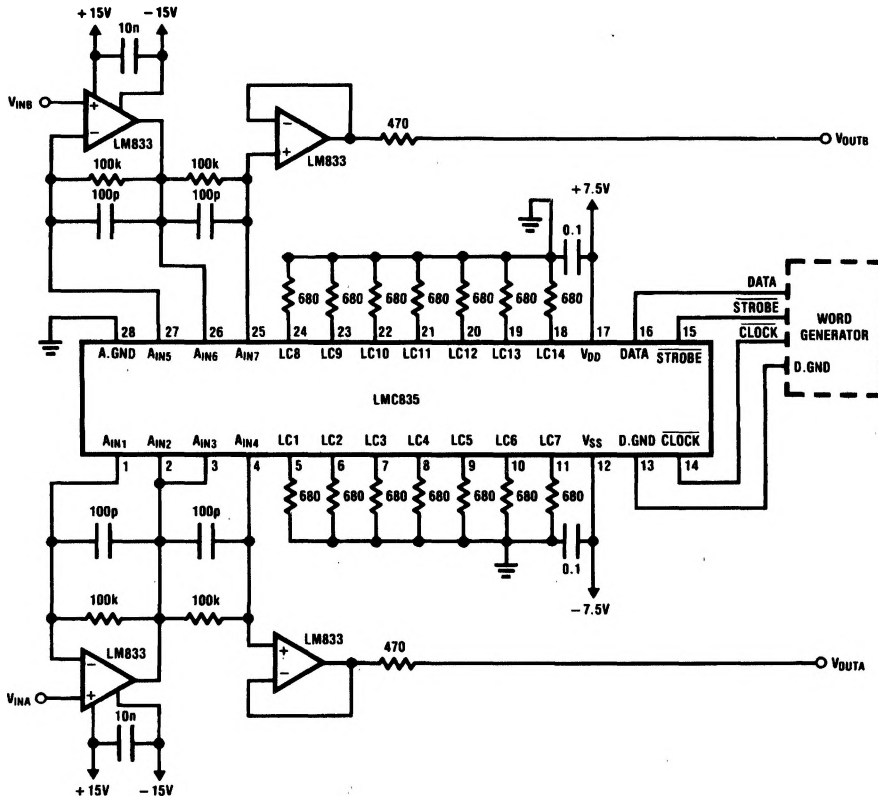

FIGURE 3. Test Circuit for AC Measurement

TL/H/6753-5

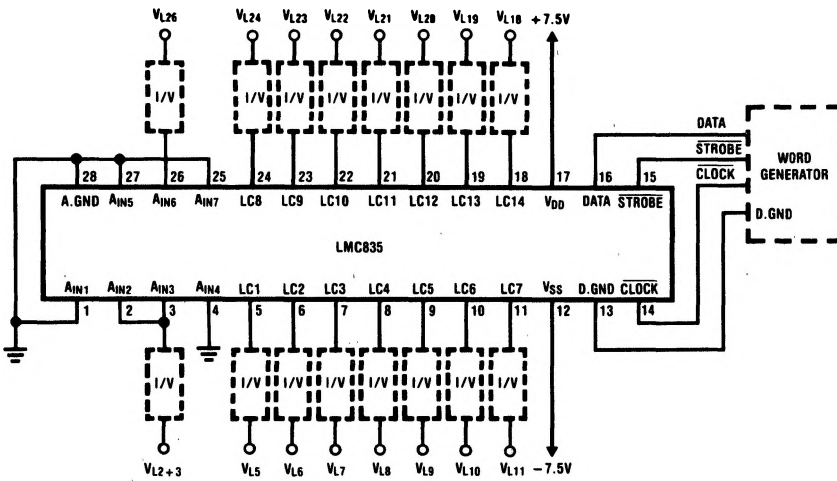

FIGURE 4. Test Circuit for Leakage Current Measurement

TL/H/6753-6

Test Circuits (Continued)

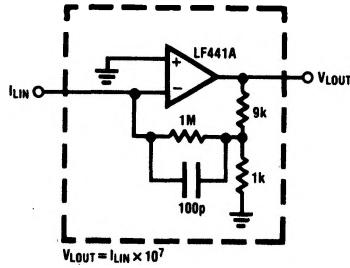
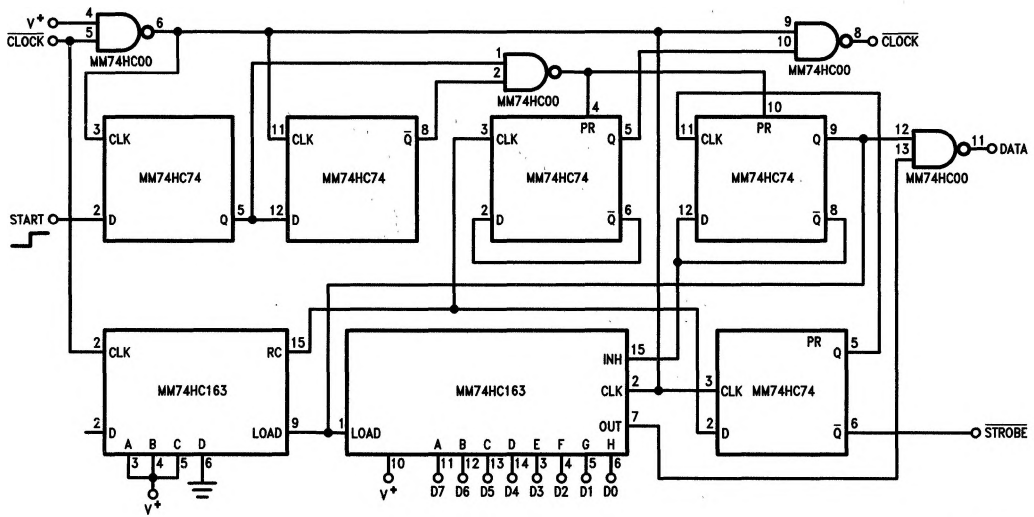

FIGURE 5. I to V Converter

TL/H/6753-7



TL/H/6753-8

FIGURE 6. Simple Word Generator

Typical Performance Characteristics

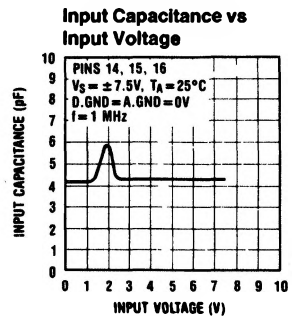
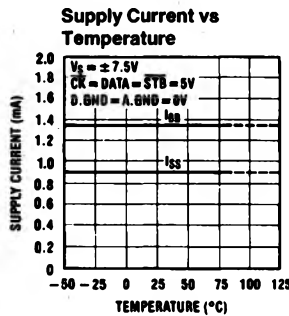
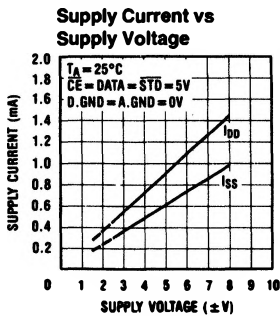

TL/H/6753-9

Typical Performance Characteristics (Continued)

Maximum Output Voltage vs Supply Voltage

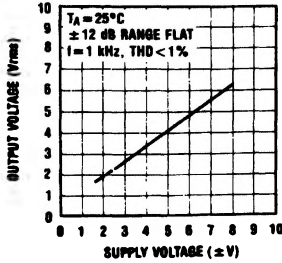

Maximum Output Voltage vs Temperature

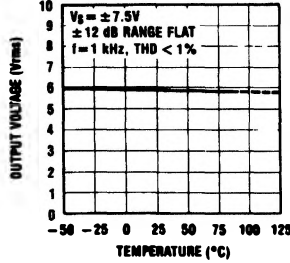

Nominal Resistor vs Temperature

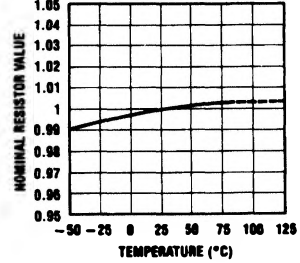

Distortion vs Frequency @ ±12 dB Range

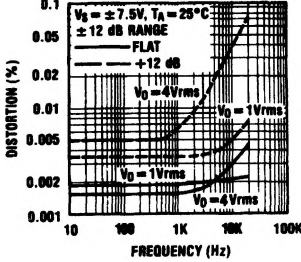

Distortion vs Frequency @ ±6 dB Range

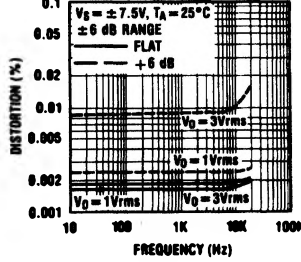

Distortion vs Output Voltage @ ±12 dB Range

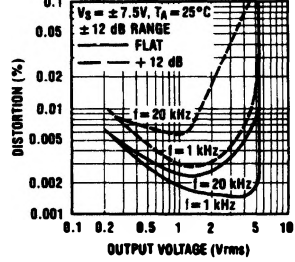

Distortion vs Output Voltage @ ±6 dB Range

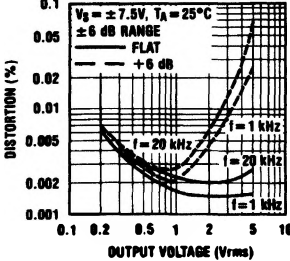

Gain vs Frequency @ ±12 dB Range (Boost)

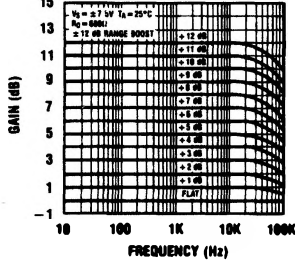

Gain vs Frequency @ ±12 dB Range (Cut)

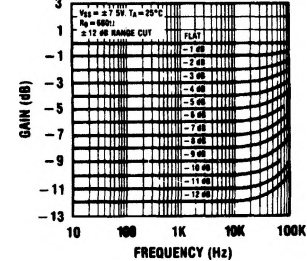

Gain vs Frequency @ ±6 dB Range (Boost)

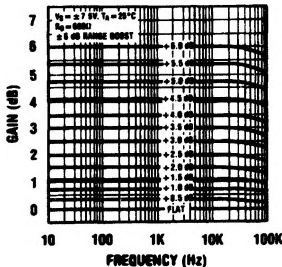

Gain vs Frequency @ ±6 dB Range (Cut)

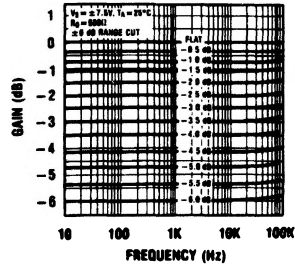

Gain vs Temperature

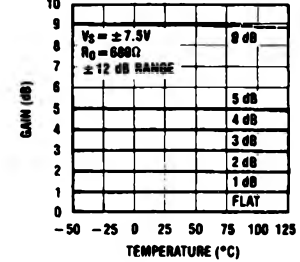

# Typical Applications

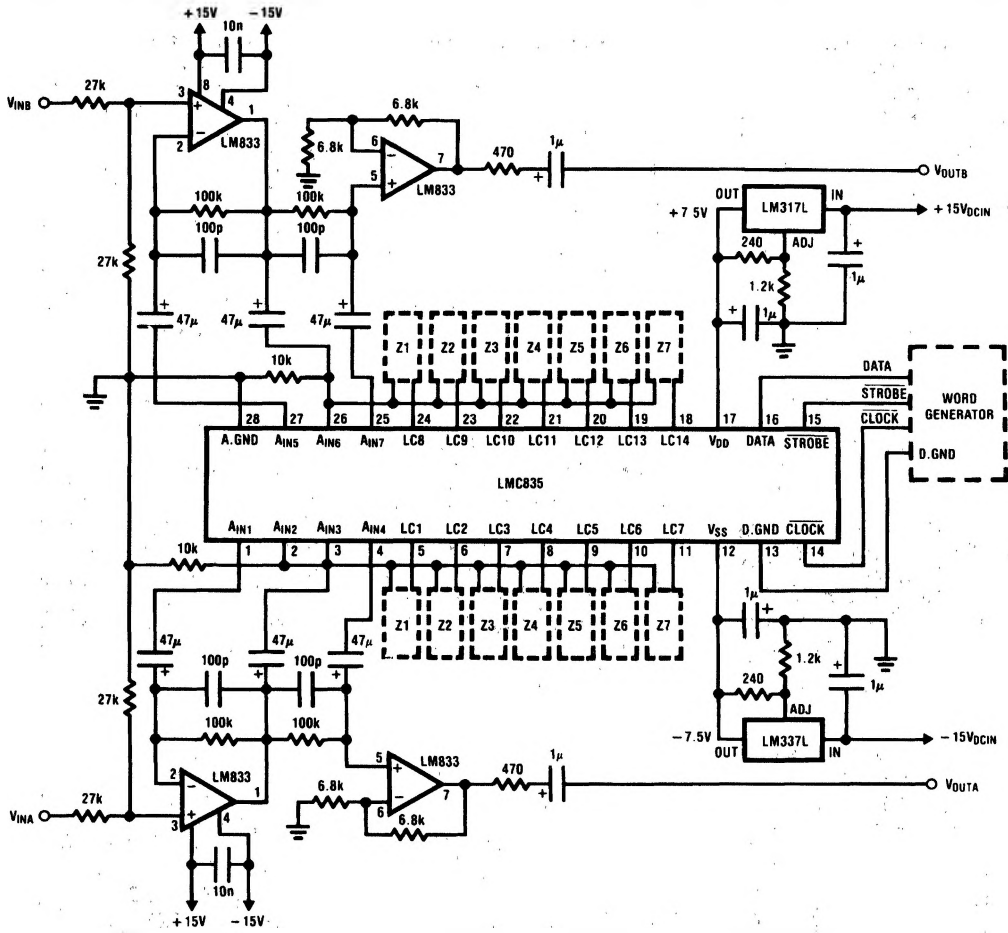
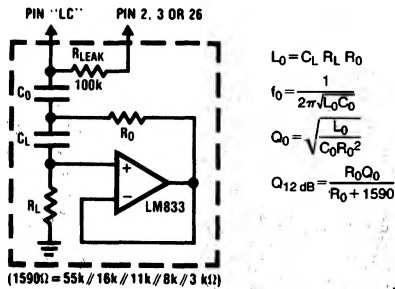

FIGURE 7. Stereo 7-Band Equalizer

TL/H/6753-11

TABLE I: Tuned Circuit Elements

Q <sub>0</sub> = 3.5, Q <sub>12dB</sub> = 1.05					
Z1	f <sub>0</sub> (Hz)	C <sub>0</sub> (F)	C <sub>L</sub> (F)	R <sub>L</sub> (Ω)	R <sub>O</sub> (Ω)
Z1	63	1 μ	0.1 μ	100k	680
Z2	160	0.47 μ	0.033 μ	100k	680
Z3	400	0.15 μ	0.015 μ	100k	680
Z4	1k	0.068 μ	0.0068 μ	82k	680
Z5	2.5k	0.022 μ	0.0033 μ	82k	680
Z6	6.3k	0.01 μ	0.0015 μ	62k	680
Z7	16k	0.0047 μ	680p	47k	680



(1590Ω = 55k / 16k // 11k // 8k // 3 kΩ)

$$L_0 = C_L R_L R_0$$

$$f_0 = \frac{1}{2\pi\sqrt{L_0 C_0}}$$

$$Q_0 = \sqrt{\frac{L_0}{C_0 R_0^2}}$$

$$Q_{12dB} = \frac{R_0 Q_0}{R_0 + 1590}$$

TL/H/6753-12

FIGURE 8. Tuned Circuit for Stereo 7-Band Equalizer (Figure 7)

Typical Applications (Continued)

Performance Characteristics (Circuit of Figure 7)

LMC835 Gain vs Frequency  
@ ± 12 dB Range  
(All Boost or Cut)

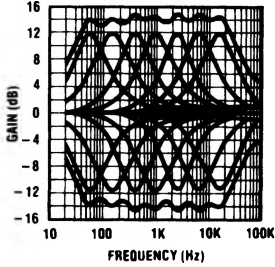

LMC835 Gain vs Frequency  
@ ± 12 dB Range  
(1 kHz Boost or Cut)

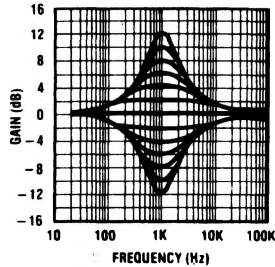

LMC835 Gain vs Frequency  
@ ± 6 dB Range  
(All Boost or Cut)

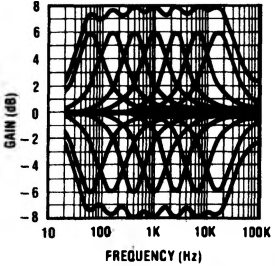

LMC835 Gain vs Frequency  
@ ± 6 dB Range  
(1 kHz Boost or Cut)

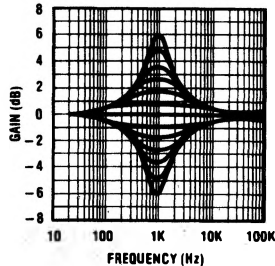

TL/H/6753-13

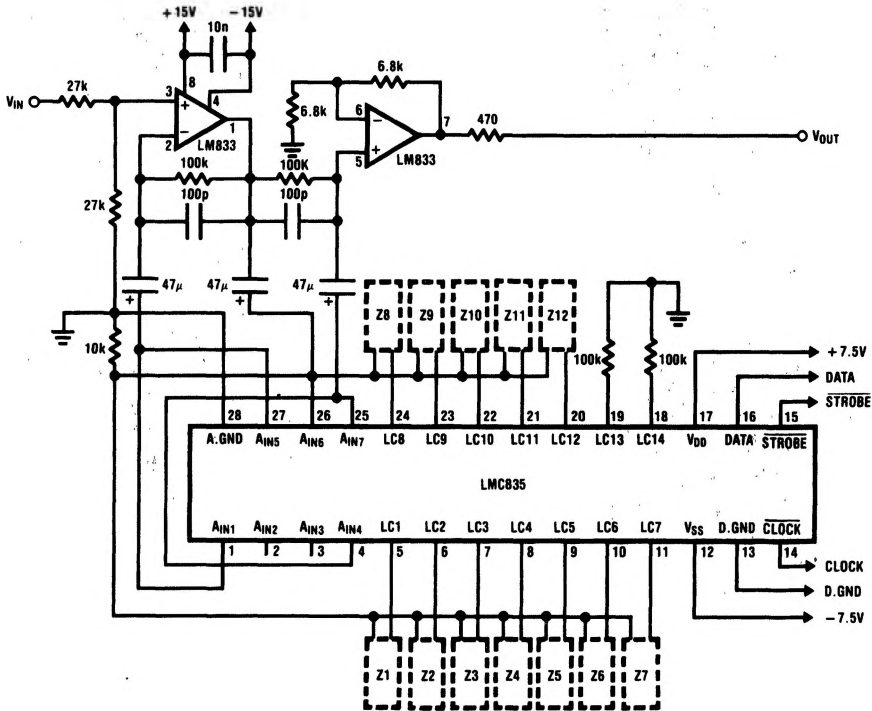

FIGURE 9. 12-Band Equalizer

TL/H/6753-14

Typical Applications (Continued)

TABLE II. Tuned Circuit Elements

Q <sub>0</sub> = 4.7, Q <sub>12</sub> dB = 1.4					
	f <sub>0</sub> (Hz)	C <sub>0</sub> (F)	C <sub>L</sub> (F)	R <sub>L</sub> (Ω)	R <sub>0</sub> (Ω)
Z1	16	3.3μ	0.47μ	100k	680
Z2	31.5	15μ	0.22μ	110k	680
Z3	63	1μ	0.1μ	100k	680
Z4	125	0.39μ	0.068μ	91k	680
Z5	250	0.22μ	0.033μ	82k	680
Z6	500	0.1μ	0.015μ	100k	680
Z7	1k	0.047μ	0.01μ	82k	680
Z8	2k	0.022μ	0.0047μ	91k	680
Z9	4k	0.01μ	0.0022μ	110k	680
Z10	8k	0.0068μ	0.001μ	82k	680
Z11	16k	0.0033μ	680p	62k	680
Z12	32k	0.0015μ	470p	68k	510

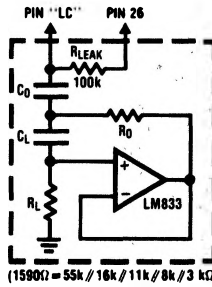

$$L_0 = C_L R_L R_0$$

$$f_0 = \frac{1}{2\pi\sqrt{L_0 C_0}}$$

$$Q_0 = \sqrt{\frac{L_0}{C_0 R_0^2}}$$

$$Q_{12\text{ dB}} = \frac{R_0 Q_0}{R_0 + 1590}$$

TL/H/6753-15

FIGURE 10. Tuned Circuit for 12-Band Equalizer (Figure 9)

Performance Characteristics (Circuit of Figure 9)

12 Band Equalizer Application  
LMC835 Gain vs Frequency  
@ ± 6 dB Range  
(All Boost or Cut)

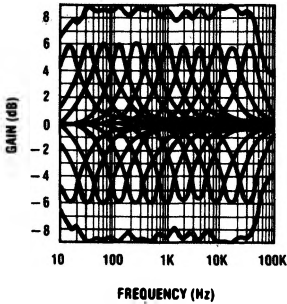

LMC835 12 Band E.Q. Application  
Gain vs Frequency  
@ ± 12 dB Range  
(1 kHz Boost or Cut)

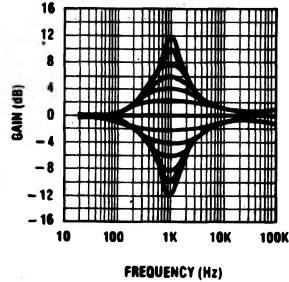

12 Band Equalizer Application  
LMC835 Gain vs Frequency  
@ ± 12 dB Range  
(All Boost or Cut)

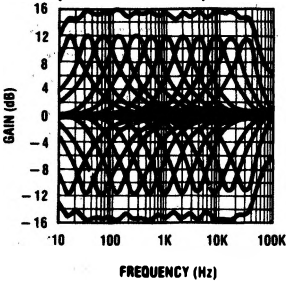

LMC835 12 Band E.Q. Application  
Gain vs Frequency  
@ ± 6dB Range  
(1 kHz Boost or Cut)

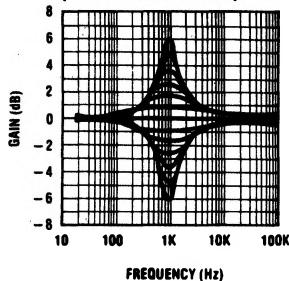

TL/H/6753-16

Typical Applications (Continued)

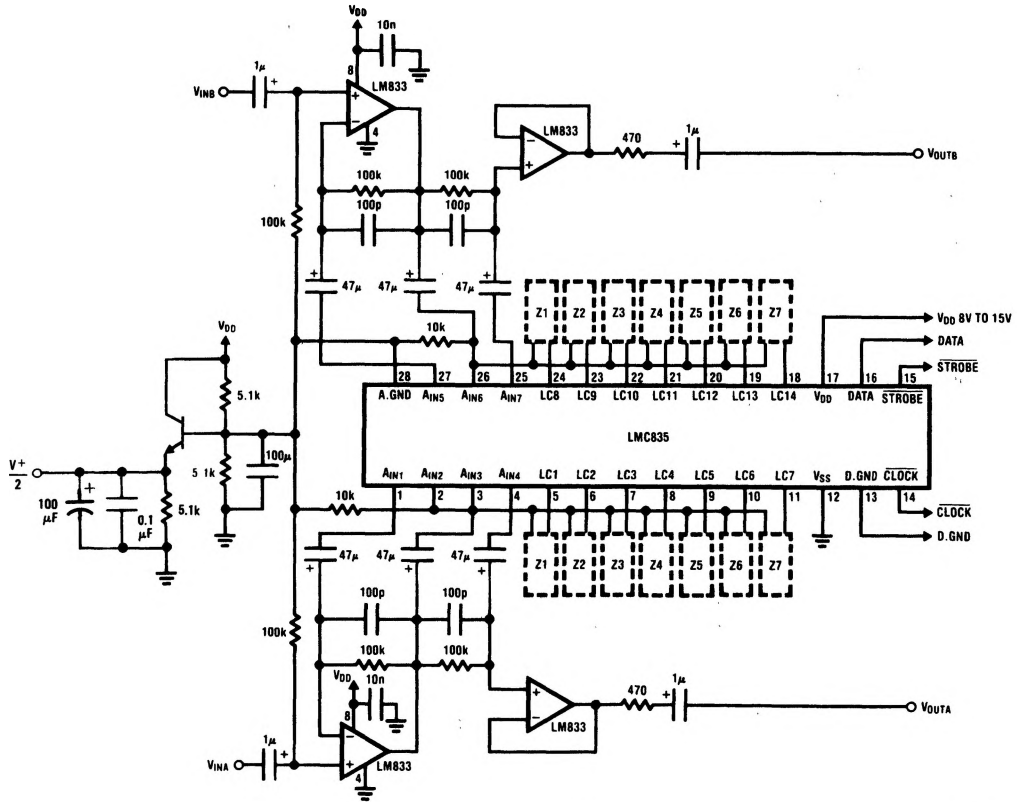
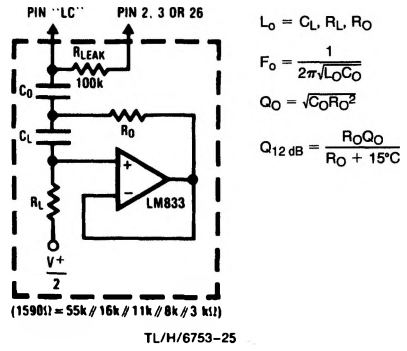

TL/H/6753-17

The  $\frac{V^+}{2}$  output is used to bias the gyrators

FIGURE 11. Single Supply Stereo Equalizer

Typical Applications (Continued)

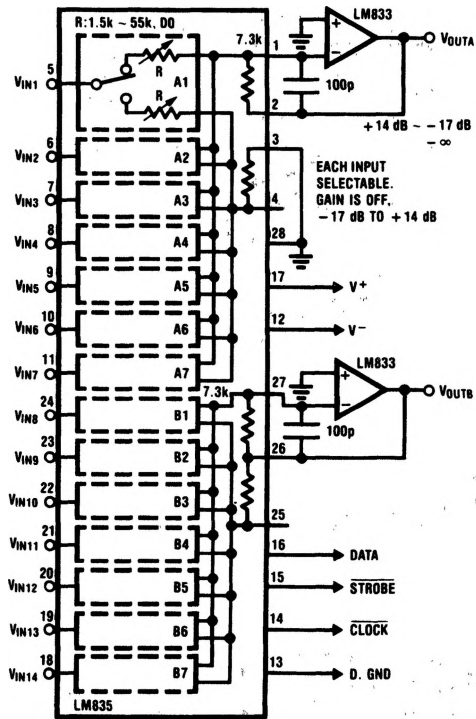

FIGURE 12. Stereo 7-input/1-Output Mixers (THD is not as low as equalizer circuit)

TL/H/6753-18

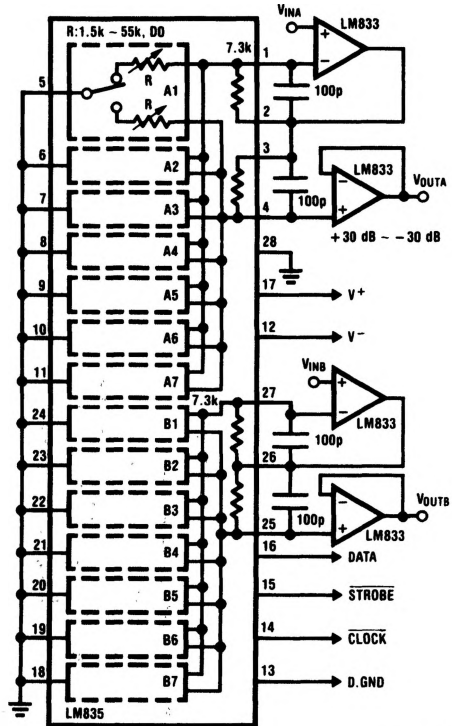

FIGURE 13. Stereo Volume Control, Very Low THD

TL/H/6753-19

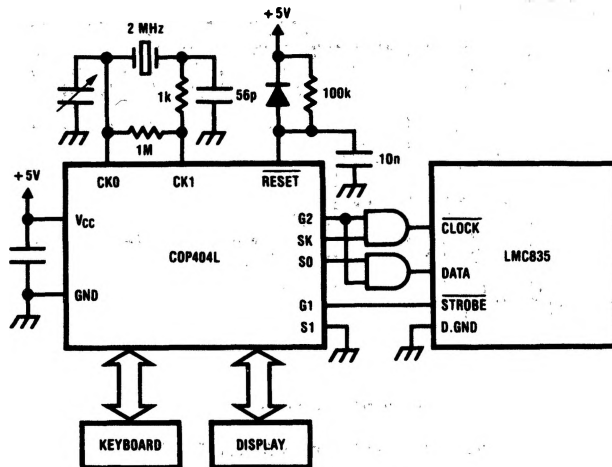

FIGURE 14. LMC835-COP404L CPU Interface

TL/H/6753-20

## Typical Applications (Continued)

### Sample Subroutine Program for Figure 14, LMC835-COP404L CPU Interface

HEX CODE	LABEL	MNEMONICS	COMMENTS
3F	LMC835:	LBI 3F	;POINT TO RAMADDRESS 3F
05	SEND	LD	;RAMDATA TO A
22		SC	; SET CARRY
335F		OGI	;SET PORT G= 1111, OPEN THE AND GATES
4F		XAS	;SWAP A AND SIO, CLOCK START
05		LD	;RAMDATA TO A, MAKE SURE A = DATA
07		XDS	;SWAP A AND RAMDATA, RAMADDRESS=RAMADDRESS-1
05		LD	;RAMDATA TO A
4F		XAS	;SWAP A AND SIO
05		LD	;RAMDATA TO A, MAKE SURE A=NEWDATA
07		XDS	;SWAP A AND RAMDATA, RAMADDRESS=RAMADDRESS-1
32		RC	;RESET CARRY
4F		XAS	;SWAP A AND SIO, CLOCK STOP
335D		OGJ 13	;SET PORT G=1101, MAKE STROBE LOW
335B		OGI 11	;SET PORT G=1011, MAKE STROBE HIGH, CLOSE THE GATES
4E		CBA	;BD TO A
43		AISC 3	;RAMADDRESS < 3C THEN RETURN
48		RET	
80		JP SEND	

RAM		COMMENTS
ADDRESS		
3C	DATA	;GAIN DATA D4-D7
3D	DATA	;GAIN DATA D0-D3
3E	DATA	;BAND DATA D4-D7
3F	DATA	;BAND DATA D0-D3

## Application Hints

### SWITCHING NOISE

The LMC835 uses CMOS analog switches that have small leakages (less than 50 nA). When a band is selected for flat gain, all the switches in that band are open and the resonator circuit is not connected to the LMC835 resistor network. It is only in the flat mode that the small leakage currents can cause problems. The input to the resonator circuit is usually a capacitor and the leakage currents will slowly charge up this capacitor to a large voltage if there is no resistive path to limit it. When the band is set to any value other than flat, the charge on the capacitor will be discharged by the resistor network and there will be a transient at the output. To limit the size of this transient,  $R_{LEAK}$  is necessary.

### HOW TO AVOID SWITCHING NOISE DUE TO LEAKAGE CURRENT (Refer to Figures 7 and 8)

To avoid switching noise due to leakage currents when changing the gain, it is recommended to put  $R_{LEAK} = 100$  k $\Omega$  between Pin 3 and Pin 5—11 each, Pin 26 and Pin 12—24 each. The resistor limits the voltage that the capacitor can charge to, with minimal effects on the equalization. The frequency response change due to  $R_{LEAK}$  are shown in Figure 15. The gain error is only 0.2 dB and Q error is only 5% at 12 dB boost or cut.

### SIMPLE WORD GENERATOR (Figure 6)

Circuit operation revolves around an MM74HC165 parallel-in/serial-out shift register. Data bits D0 through D7 are applied to the parallel of the MM74HC165 from 8 toggle switches. The bits are shifted out to the DATA input of the LMC835 in sync with the clock. When all data bits have been loaded, CLOCK is inhibited and a STROBE pulse is generated: this sequence is initiated by a START pulse.

### LMC835-COP404L CPU INTERFACE (Refer to Figure 14)

The diagram shows AND gates between the COP and the LMC835. These permit G2 to inhibit the CLOCK and DATA lines (SK and SO) during a STROBE (G1) pulse. This function may also be implemented in software. As shown in Figure 2, the data groups are shifted in D0 first. Data is loaded on positive clock edges.

### POWER SUPPLIES

These applications show LM317/337 regulators for the  $\pm 7.5$ V supplies for the LMC835. Since the latter draws only 5 mA max., 1k series dropping resistors from the  $\pm 15$ V op amp supply and a pair of 7.5V zeners and bypass caps will also suffice.

### Application Hints (Continued)

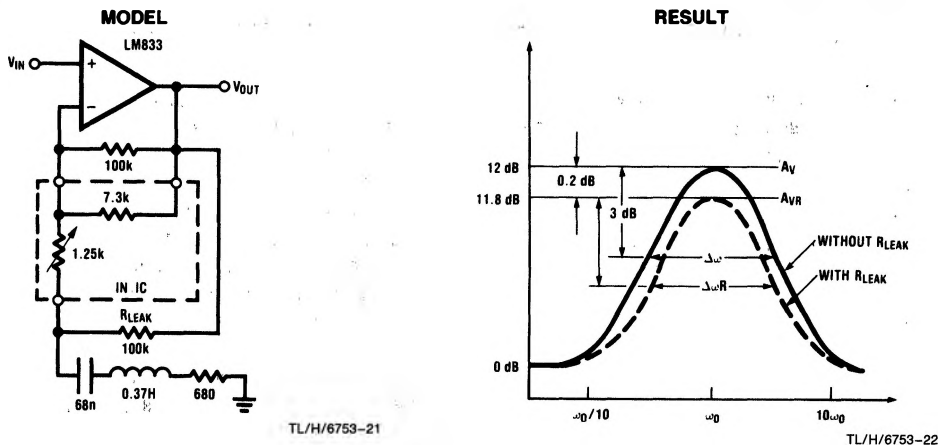

TL/H/6753-21

TL/H/6753-22

FIGURE 15. Effect of  $R_{LEAK}$

### REDUCING EXTERNAL COMPONENTS

The typical application shown in Figure 7 is switching noise free. The DC-coupled circuit in Figure 16 is also switching noise free, except at 12 dB/6 dB switch turn ON/OFF. This switching noise is caused by the  $I_{bias}$  and  $V_{offset}$  of the op

amps. Selecting a low  $I_{bias}$  and  $V_{offset}$  op amp can minimize the switching noise due to the 12 dB/6 dB switch. The DC-coupled application can also eliminate the  $R_F = 100k$  resistors with only a 0.5 dB gain error at 12 dB boost or cut.

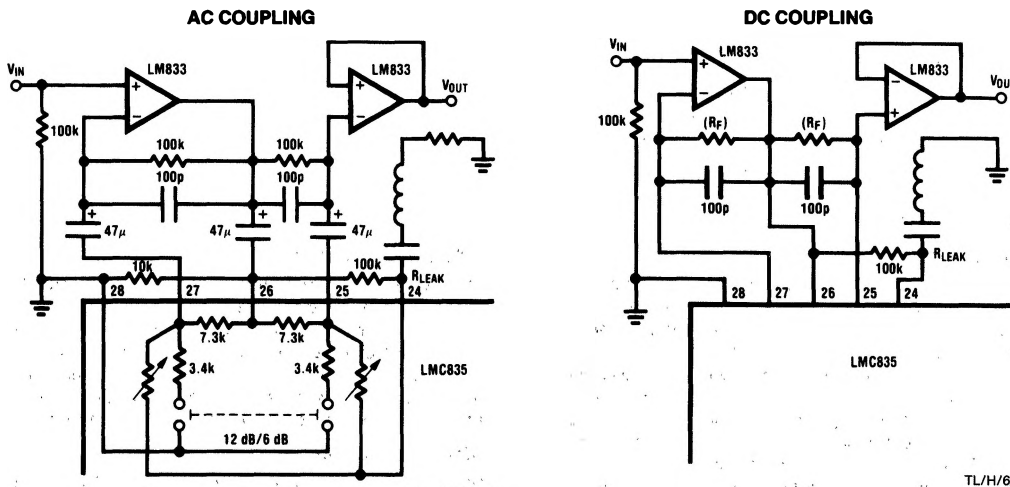

TL/H/6753-23

TL/H/6753-24

FIGURE 16. Reducing External Components