

LM9044 Lambda Sensor Interface Amplifier

General Description

The LM9044 is a precision differential amplifier specifically designed for operation in the automotive environment. Gain accuracy is guaranteed over the entire automotive temperature range (-40°C to $+125^{\circ}\text{C}$) and is factory trimmed prior to package assembly. The input circuitry has been specifically designed to reject common-mode signals as much as 3V below ground on a single positive power supply. This facilitates the use of sensors which are grounded at the engine block while the LM9044 itself is grounded at chassis potential. An external capacitor sets the maximum operating frequency of the amplifier, thereby filtering high frequency transients. Both inputs are protected against accidental shorting to the battery and against load dump transients. The input impedance is typically $1\text{ M}\Omega$.

The output op amp is capable of driving capacitive loads and is fully protected. Also, internal circuitry has been pro-

vided to detect open circuit conditions on either or both inputs and force the output to a "home" position (a ratio of the external reference voltage).

Features

- Normal circuit operation guaranteed with inputs up to 3V below ground on a single supply
- Gain factory trimmed and guaranteed over temperature ($\pm 3\%$ of full-scale from -40°C to $+125^{\circ}\text{C}$)
- Low power consumption (typically 1 mA)
- Fully protected inputs
- Input open circuit detection
- Operation guaranteed over the entire automotive temperature range (-40°C to $+125^{\circ}\text{C}$)
- Single supply operation

Schematic and Connection Diagrams

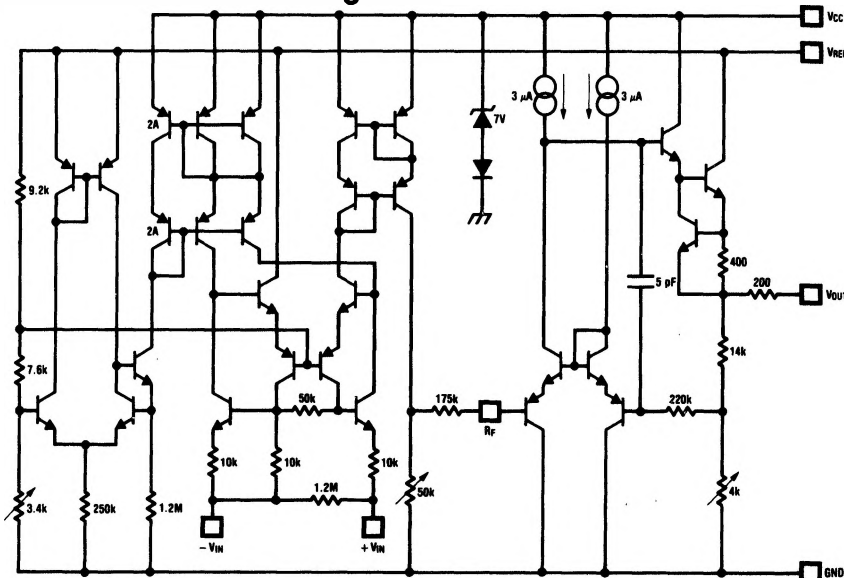

TL/H/6744-1

Plastic Chip Carrier Package

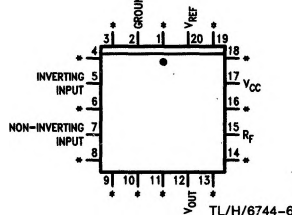

TL/H/6744-6

Order Number LM9044V
See NS Package Number V20A

*Pins 1, 3, 4, 6, 8, 9, 10, 11, 13, 14, 16, 18, 19 are trim pins and should be left floating.

Top View

Absolute Maximum Ratings

If Military/Aerospace specified devices are required, please contact the National Semiconductor Sales Office/Distributors for availability and specifications.

V _{CC} Supply Voltage (R _{VCC} = 15 k Ω)	$\pm 60V$
V _{REF} Supply Voltage	-0.3V to +6V
DC Input Voltage (Either Input)	-3V to +16V
Input Transients (Note 1)	$\pm 60V$
Power Dissipation (see Note 6)	1350 mW
Output Short Circuit Duration	Indefinite

Operating Temperature Range	-40°C to +125°C
Storage Temperature Range	-65°C to +150°C

Soldering Information	
Plastic Chip Carrier Package	215°C
Vapor Phase (60 seconds)	220°C
Infrared (15 seconds)	220°C

See AN-450 "Surface Mounting Methods and Their Effect on Product Reliability" for other methods of soldering surface mount devices.

Electrical Characteristics

V_{CC} = 12V, V_{REF} = 5V, -40°C \leq T_A \leq 125°C unless otherwise noted

Parameter	Conditions	(Note 2)			(Note 3)			Units
		Min	Typ	Max	Min	Typ	Max	
Differential Voltage Gain	V _{DIF} = 0.5V -1V \leq V _{CM} \leq +1V	4.41	4.50	4.59				V/V
	V _{DIF} = 0.5V, -3V \leq V _{CM} \leq +1V				4.36	4.50	4.64	V/V
Gain Error (Note 5)	0 \leq V _{DIF} \leq 1V -1V \leq V _{CM} \leq +1V	-2	0	2				%/FS
	0 \leq V _{DIF} \leq 1V -3V \leq V _{CM} \leq +1V				-3	0	3	%/FS
Differential Input Resistance	0 \leq V _{DIF} \leq 1V -1V \leq V _{CM} \leq +1V	0.95	1.20	3.00				M Ω
	0 \leq V _{DIF} \leq 1V -3V \leq V _{CM} \leq +1V				0.70	1.20	4.00	M Ω
Non-Inverting Input Bias Current	0 \leq V _{DIF} \leq 1V -1V \leq V _{CM} \leq +1V		± 0.38	± 0.65				μA
	0 \leq V _{DIF} \leq 1V -3V \leq V _{CM} \leq +1V				± 0.38	± 1.5		μA
Inverting Input Bias Current	0 \leq V _{DIF} \leq 1V -1V \leq V _{CM} \leq +1V	-25	-65	-100				μA
	0 \leq V _{DIF} \leq 1V -3V \leq V _{CM} \leq +1V				-45	-150		μA
V _{CC} Supply Current	V _{CC} = 12V, R _{VCC} = 15k		300	500				μA
V _{REF} Supply Current	4.75V \leq V _{REF} \leq 5.5V		0.5	1.0				mA
Common-Mode Voltage Range (Note 4)		-1		1	-3		1	V
DC Common-Mode Rejection Ratio	Input Referred -1V \leq V _{CM} \leq +1V V _{DIF} = 0.5V	50	60					dB
Open Circuit Output Voltage	One or Both Inputs Open, -1V \leq V _{CM} \leq +1V	0.371	0.397	0.423				XV _{REF}
	-3V \leq V _{CM} \leq +1V				0.365	0.397	0.429	XV _{REF}
Short Circuit Output Current	Output Grounded	1.0	2.7	5.0				mA
V _{CC} Power Supply Rejection Ratio	V _{CC} = 12V, R _{VCC} = 15K V _{DIF} = 0.5V	50	65					dB
V _{REF} Power Supply Rejection Ratio	V _{REF} = 5 V _{DC} V _{DIF} = 0.5V	60	74					dB

Note 1: This test is performed with a 1000 Ω source impedance.

Note 2: These parameters are guaranteed and 100% production tested.

Note 3: These parameters will be guaranteed but not 100% production tested.

Note 4: The LM9044 has been designed to common-mode to -3V, but production testing is only performed at $\pm 1V$.

Note 5: Gain error is given as a percent of full-scale. Full-scale is defined as 1V at the input and 4.5V at the output.

Note 6: For operation in ambient temperatures above 25°C the device must be derated based on a maximum junction temperature of 150°C and a thermal resistance of 93°C/W junction to ambient.

Typical Performance Characteristics

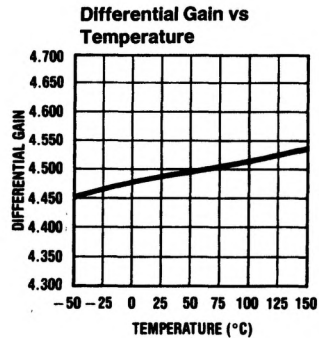
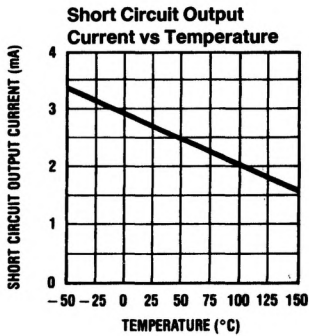
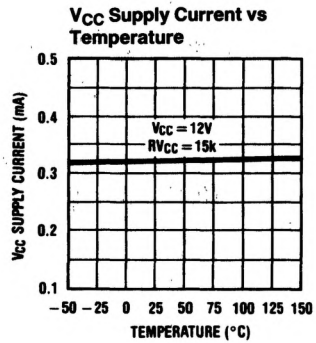
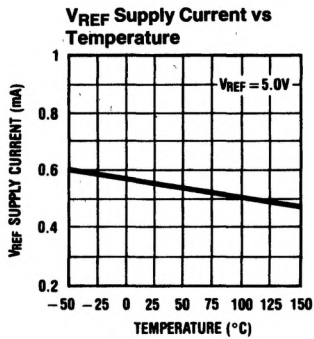
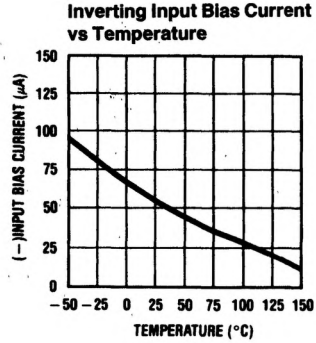
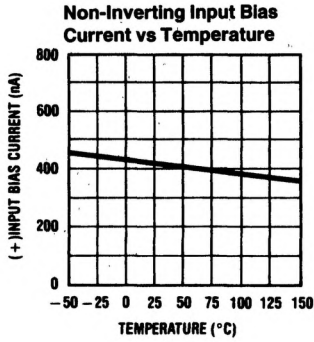

TL/H/6744-3

Typical Performance Characteristics (Continued)

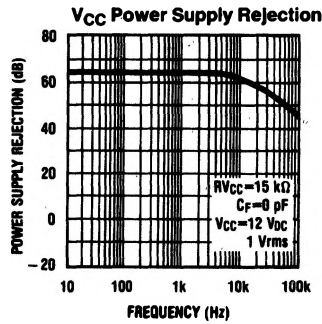
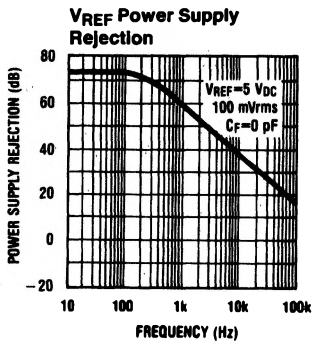
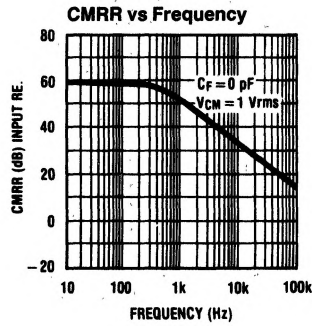
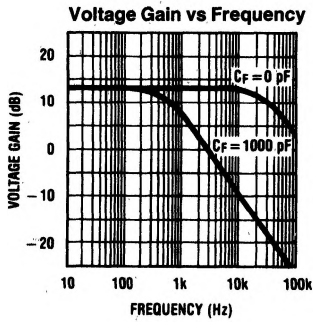

TL/H/6744-4

Test Circuit

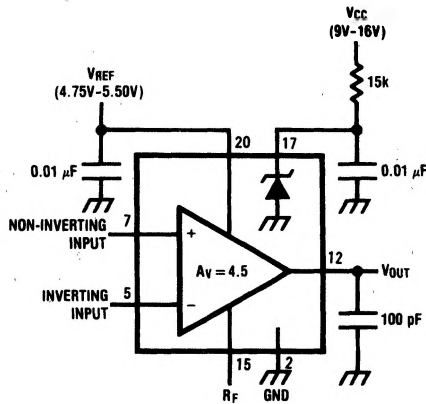

TL/H/6744-5