

LM903 Fluid Level Detector

General Description

The LM903 uses the thermal-resistive probe technique to measure the level of nonflammable fluids. A low fluid level is indicated by a warning lamp operating in continuous or flashing mode. All supervisory requirements to control the thermal-resistive probe, including short and open circuit probe detection, are incorporated within the device. The circuit has possible applications in the detection of hydraulic fluid, oil level, etc., and may be used with partially conducting fluids.

Features

- Flashing or continuous warning indication
- Warning threshold externally adjustable
- Control circuitry for thermal-resistive probe
- Switch on reset and delay to avoid transients
- 600 mA flashing lamp drive capability
- Short and open circuit probe detection
- 70V transient protection on supply and control input
- 7V–18V supply range
- Internally regulated supply
- –40°C to +80°C operation

Connection Diagram

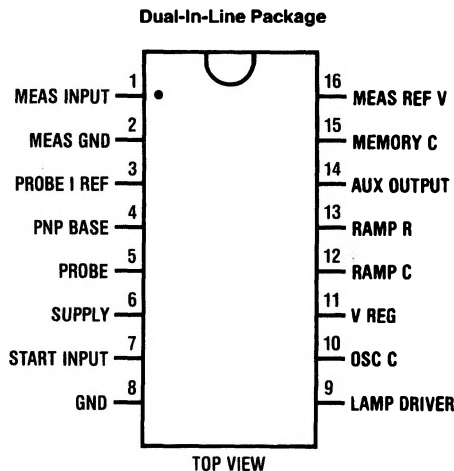

TL/H/5699-1

Order Number **LM903N**
See NS Package Number **N16E**

Absolute Maximum Ratings

If Military/Aerospace specified devices are required, please contact the National Semiconductor Sales Office/Distributors for availability and specifications.

Supply Voltage, V_{CC}	18V
Control Input Voltage (Pin 7)	18V
Transient Voltage (Pins, 6, 7, 9) 10 ms (Note 1)	70V
Output Current (Pin 4) I_4 (Sink)	10 mA

Operating Temperature Range	-40°C to +85°C
Storage Temperature	-55°C to +150°C
Maximum Junction Temperature	+150°C
Lead Temperature (Soldering, 10 sec.)	260°C

Electrical Characteristics

$V_{CC} = 12V$, $C_T = 33 \mu F$, $R_T = 7.5 k\Omega$, T_A within operating range except where stated otherwise

Symbol	Parameter	Conditions	Tested Limits (Note 2)		Design Limits (Note 3)			Units
			Min	Max	Min	Typ	Max	
V_{CC}	Supply Voltage		7.0	18	7.0	13	18	V
I_S	Supply Current			50			50	mA
V_{REG}	Regulated Voltage		5.5	6.2	5.3	5.8	6.3	V
	Regulation Temperature Drift	$V_{CC} = 7.2V-18V$		105		500		mV $\mu V/^\circ C$
V_6-V_3	Probe Current Reference Voltage		2.0	2.35	1.95	2.20	2.40	V
V_{REF}	Measurement Reference Voltage		790	900	780	850	910	mV
R_{REF}	Reference Input Resistor					1.2		k Ω
V_7	Start Input Logic High Level				1.6			V
V_7	Start Input Logic Low Level						1.0	V
I_7	High Input Current	Latch Off					100	nA
I_7	Latch Holding Current	Latch On				2.5		nA
R_7	Resistance Pin 7	Latch On				22		k Ω
I_{12}	Ramp Current	See Timing Diagram						
	Charging	$V_{12} = 0V-1V$	600	1100	590		1100	μA
		$V_{12} = 1V-4V$	53	93	50		96	μA
	Discharging	$V_{12} = 4.1V$	-700	-450	-710		-440	μA
$V_{12} = 0.5V$		-650	-400	-660		-390	μA	
V_{12}	Ramp Threshold	See Timing Diagram						
	Probe Current Start		570	850	550	710	870	mV
	First Measurement		910	1200	890	1055	1220	mV
	Second Measurement		910	1240	890	1080	1270	mV
V_1	Probe Input Voltage Range	$V_{CC} = 7.5V-18V$			1		$V_{REG} - 1.0$	V
V_5	Probe Open-Circuit Threshold	At Pin 5			$V_{REG} - 0.85$	$V_{REG} - 0.6$		V
V_5	Probe Short-Circuit Threshold					0.6	0.85	V
I_1	Pin 1 Input Leakage Current	Pin 1 = 300 mV	-3.5	+3.5			+5.0	nA
I_{15}	Pin 15 Leakage Current	$V_{15} = 2V, V_7 = 12V$	-3.5	3.5				μA
	Pin 15 Charging Current	$V_{15} = 4V, V_7 = 12V$	60					μA
f_g	Lamp Oscillation Frequency	$C_L = 3.3 \mu F$			0.5	1.5	2.5	Hz
I_g	Lamp Driver Current	Flashing Mode					600	mA
V_g	Lamp Driver Saturation	$I_g = 200 \text{ mA}$		200			250	mA

Electrical Characteristics (Continued)

$V_{CC} = 12V$, $C_T = 33 \mu F$, $R_T = 7.5 k\Omega$, T_A within operating range except where stated otherwise

Symbol	Parameter	Conditions	Tested Limits (Note 2)		Design Limits (Note 3)			Units
			Min	Max	Min	Typ	Max	
V_{14}	Auxiliary Output Voltage	Lamp OFF			5.0			V
		Lamp ON					1.2	V
V_1	Alarm Level	(Difference Between First and Second Measurement)			230	280	330	mV

Sensitivity to Electrostatic Discharge: Pins 7, 10, 13, and 14 will withstand greater than 1500V when tested using 100 pF and 1500 Ω in accordance with National Semiconductor standard ESD test procedures. All other pins will withstand in excess of 2 kV.

Note 1: Test circuit for overvoltage capability at pins 3, 6, 7.

Note 2: Guaranteed 100% production tested at 25°C. These limits are used to calculate outgoing quality levels.

Note 3: Limits guaranteed to include parametric variations. $T_A = -40^\circ C$ to $+80^\circ C$ and from $V_{CC} = 7.5V-18V$. These limits are not used to calculate AOQL figures.

Note 4: Variations over temperature range are not production tested.

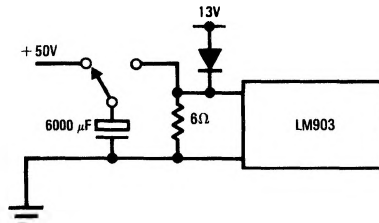

In Lamp ON condition, I_9 should be limited to 600 mA.

Block and Application Circuit

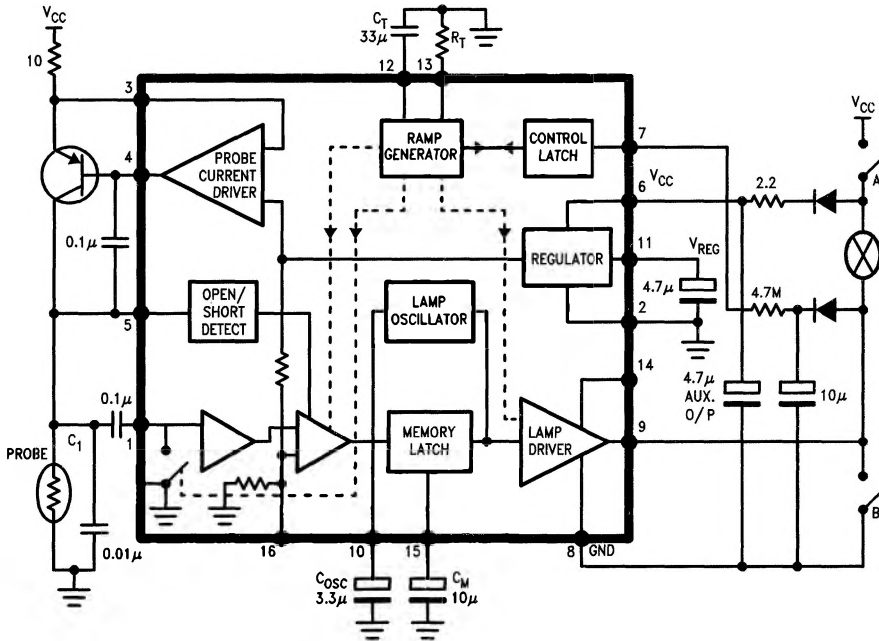

Memory capacitor on pin 15 is set
High—Lamp off
Low—Lamp on

Circuit Timing Diagram

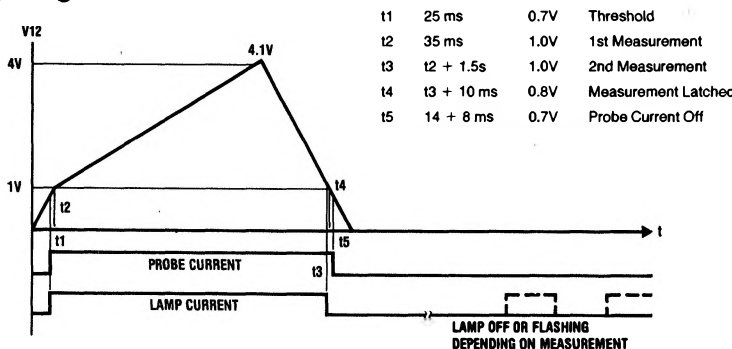

TL/H/5699-4

Circuit Operation

A measurement is initiated when the supply is applied, provided the control input pin 7 is low. Once a measurement is commenced, pin 7 is latched low and the ramp capacitor on pin 12 begins to charge. After 25 ms when switch-on transients have subsided, a constant current is applied to the thermo-resistive probe. The value of probe current, which is supplied by an external PNP transistor, is set by an external resistor across an internally generated 21V reference. The lamp current is applied at the start of probe current.

35 ms after switch-on, the voltage across the probe is sampled and held on external capacitor C1 (leakage current at pin 1 less than 1 nA). After a further 1.5 seconds the difference between the present probe voltage and the initial probe voltage is measured, multiplied by 3 and compared with a reference voltage of 850 mV (externally adjustable via pin 16). If the amplified voltage difference is less than the reference voltage the lamp is switched off, otherwise the lamp commences flashing at 1 Hz to 2 Hz. 10 ms later the measurement latch operates to store the result and after a further 8 ms the probe current is switched off.

A second measurement can only be initiated by interrupting the supply. An external CR can be arranged on pin 7 to prevent a second measurement attempt for 1 minute. The measurement condition stored in the latch will control the lamp.

PROBES

The circuit effectively measures the thermal resistance of the probe. This varies depending on the surrounding medium (*Figure 1*). It is necessary to be able to heat the probe with the current applied and, for there to be sufficient change in resistance with the temperature change, to provide the voltage to be measured.

Probes require resistance wire with a high resistivity and temperature coefficient. Nickel cobalt alloy resistance wires are available with resistivity of $50 \mu\Omega\text{cm}$ and temperature coefficient of 3300 ppm which can be made into suitable probes. Wires used in probes for use in liquids must be designed to drain freely to avoid clogging. A possible arrangement is shown in *Figure 2*.

The probe voltage has to be greater than 0.7V to prevent short circuit probe detection less than 5V to avoid open circuit detection. With a 200 mA probe current this gives a probe resistance range of 4Ω to 25Ω . This low value makes it possible to use the probe in partially conducting fluids.

Using resistance wire of $50 \mu\Omega\text{cm}$ resistivity, 8 cm of 0.08 mm (40 AWG) give approximately 8Ω at 25°C . Such a probe will give about 500 mV change between first and second measurements in air, and 100 mV change with oil, hydraulic fluid, etc., in the application circuit. With an alarm threshold of 280 mV (typ) lack of fluid can readily be detected. As the probe current, measurement reference and measurement period are all externally adjustable, there is freedom to use different probes and fluids.

Another possibility is the use of high temperature coefficient resistors made for special applications and positive temperature coefficient thermistors. The encapsulation must have a sufficiently low thermal resistance so as not to mask the change due to the different surrounding mediums, and the thermal time constant must be quick enough to enable the temperature change to take place between the two measurements. The ramp timing could be adjusted to assist this. Probes in liquids must be able to drain freely.

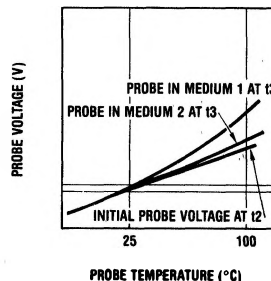

FIGURE 1. Typical Thermo-Resistive Probe

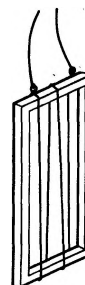

FIGURE 2

TL/H/5699-5

Application Hints

INTERNAL COMBUSTION ENGINE OIL LEVEL

The basic system provides a single shot measurement when the supply is applied and has a primary application in automotive oil, hydraulic fluid and coolant monitoring. Particularly in the case of the oil level, a valid measurement is only possible before the oil is disturbed. The application circuit shown is arranged such that the measurement is made when the ignition is switched on via switch A. Switch B is the oil pressure sensor and is closed before the engine starts, keeping pin 7 low and enabling the measurement.

STALLING AND RESTART PROTECTION

The 4M7 resistor and 10 μ F capacitor connected to pin 7 provide the restart protection. When oil pressure builds up, switch B opens and the 10 μ F capacitor charges through the bulb. At switch-off, the capacitor discharges slowly and is capable of preventing a low state on pin 7 for 1 minute. Unless pin 7 is low, a new measurement can not be made and the previous measurement result stored in the memory capacitor on pin 15 is used to control the output.

MEMORY

The pin 15 memory output goes high if a correct measurement is made (lamp off). If the power is removed, pin 15 leakage is less than 3 μ A and the memory status is retained for some time. Provided pin 15 voltage does not fall below

3V, the memory capacitor will be refreshed on powering up again. There is no internal pull down on detecting an incorrect measurement. If it is required to use pin 15 as an output indicating the measurement result, an external pull down resistor and buffer will be required.

CONTINUOUS WARNING LAMP

The lamp can be arranged to light continuously by disabling the oscillator with a resistor of 150k or less, connected between pins 10 and 11.

REPETITIVE MEASUREMENTS

Measurements may be repeated by strobing the supply to pin 6. The probe current regulator transistor must have the same supply as pin 6, but the warning lamp can be permanently powered. The lamp will light during each measurement and will flash in between measurements when incorrect conditions are detected.

ALTERNATIVE APPLICATIONS

Gas flow detection: The cooling effect of gas flowing over a probe could be used to provide a warning signal from the LM903 in the event of gas failure.

Automatic top up: With the LM903 strobed continuously, the output may be stored, buffered, and used to drive solenoid valves to correct a fluid level as required.