

## LM831 Low Voltage Audio Power Amplifier

### General Description

The LM831 is a dual audio power amplifier optimized for very low voltage operation. The LM831 has two independent amplifiers, giving stereo or higher power bridge (BTL) operation from two- or three-cell power supplies.

The LM831 uses a patented compensation technique to reduce high-frequency radiation for optimum performance in AM radio applications. This compensation also results in lower distortion and less wide-band noise.

The input is direct-coupled to the LM831, eliminating the usual coupling capacitor. Voltage gain is adjustable with a single resistor.

### Features

- Low voltage operation, 1.8V to 6.0V
- High power, 440 mW, 8Ω, BTL, 3V
- Low AM radiation
- Low noise
- Low THD

### Applications

- Portable tape recorders
- Portable radios
- Headphone stereo
- Portable speakers

### Typical Application

Dual Amplifier with Minimum Parts

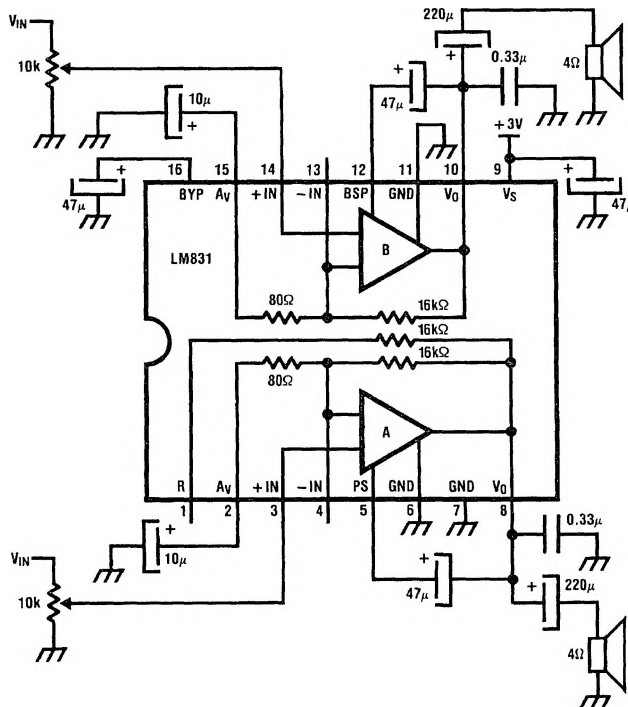

TL/H/6754-1

$A_v = 46 \text{ dB}$ , BW = 250 Hz to 35 kHz  
 $P_{OUT} = 220 \text{ mW/Ch}$ ,  $R_L = 4\Omega$

## Absolute Maximum Ratings

If Military/Aerospace specified devices are required, contact the National Semiconductor Sales Office/Distributors for availability and specifications.

Supply Voltage,  $V_S$  7.5V  
Input Voltage,  $V_{IN}$   $\pm 0.4V$

Power Dissipation (Note 1),  $P_D$  1.4W  
Operating Temperature (Note 1),  $T_{opr}$   $-40^\circ C$  to  $+85^\circ C$   
Storage Temperature,  $T_{stg}$   $-65^\circ C$  to  $+150^\circ C$   
Junction Temperature,  $T_j$   $+150^\circ C$   
Lead Temp. (Soldering, 10 sec.),  $T_L$   $+260^\circ C$

## Electrical Characteristics

Unless otherwise specified,  $T_A = 25^\circ C$ ,  $V_S = 3V$ ,  $f = 1$  kHz, test circuit is dual or BTL amplifier with minimum parts.

Symbol	Parameter	Conditions	Typ	Tested Limit	Unit (Limit)
$V_S$	Operating Voltage		3	1.8	V (Min)
			3	6	V (Max)
$I_Q$	Supply Current	$V_{IN} = 0$ , Dual Mode	5	10	mA (Max)
		$V_{IN} = 0$ , BTL Mode	6	15	mA (Max)
$V_{OS}$	Output DC Offset	$V_{IN} = 0$ , BTL Mode	10	50	mV (Max)
$R_{IN}$	Input Resistance		25	15	k (Min)
				35	k (Max)
$A_V$	Voltage Gain	$V_{IN} = 2.25$ mV <sub>rms</sub> , $f = 1$ kHz, Dual Mode	46	44 48	dB (Min) dB (Max)
PSRR	Supply Rejection	$V_S = 3V + 200$ mV <sub>rms</sub> @ $f = 1$ kHz	46	30	dB (Min)
$P_{OD}$	Power Out	$V_S = 3V$ , $R_L = 4\Omega$ , 10% THD, Dual Mode	220	150	mW (Min)
$P_{ODL}$	Power Out Low, $V_S$	$V_S = 1.8V$ , $R_L = 4\Omega$ , 10% THD, Dual Mode	45	10	mW (Min)
$P_{OB}$	Power Out	$V_S = 3V$ , $R_L = 8\Omega$ , 10% THD, BTL Mode	440	300	mW (Min)
$P_{OBL}$	Power Out Low, $V_S$	$V_S = 1.8V$ , $R_L = 8\Omega$ , 10% THD, BTL Mode	90	20	mW (Min)
Sep	Channel Separation	Referenced to $V_O = 200$ mV <sub>rms</sub>	52	40	dB (Min)
$I_B$	Input Bias Current		1	2	$\mu A$ (Max)
$E_{n0}$	Output Noise	Wide Band (250 ~ 35 kHz)	250	500	$\mu V$ (Max)
THD	Distortion	$V_S = 3V$ , $P_O = 50$ mW, $f = 1$ kHz, Dual	0.25	1	% (Max)

**Note 1:** For operation in ambient temperatures above  $25^\circ C$ , the device must be derated based on a  $150^\circ C$  maximum junction temperature and a thermal resistance of  $90^\circ C/W$  junction to ambient.

## Connection Diagram

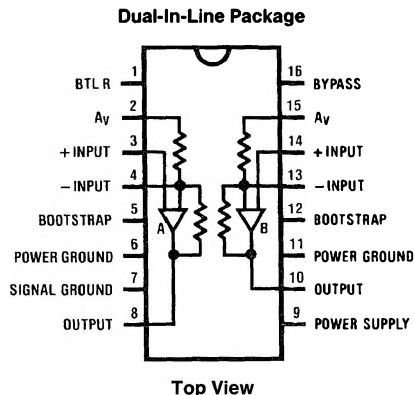

TL/H/6754-2

Order Number LM831N  
See NS Package Number N16E

# Typical Performance Characteristics

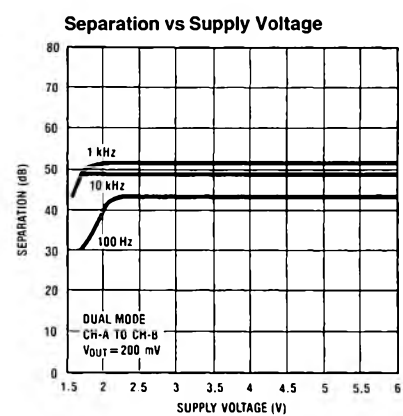
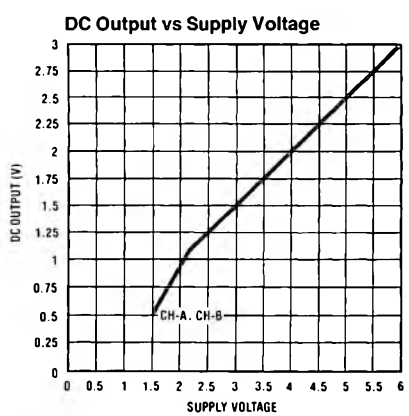
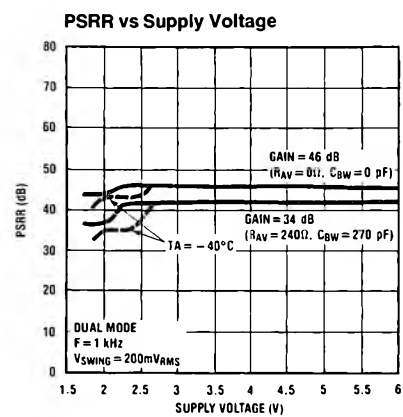
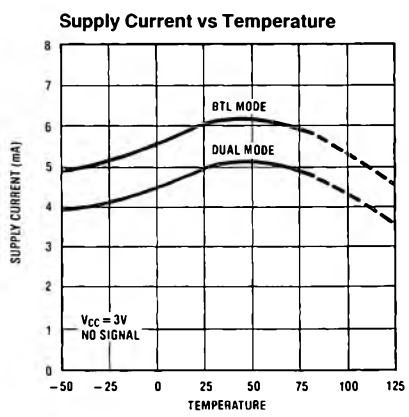
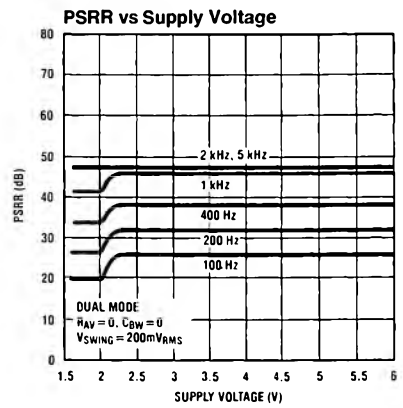
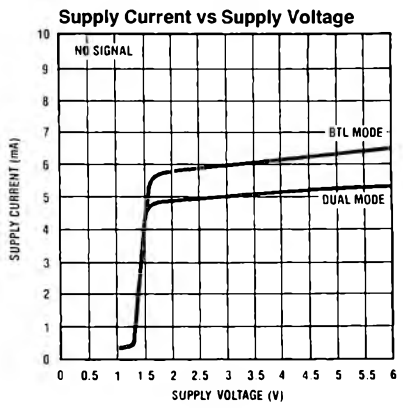

# Typical Performance Characteristics (Continued)

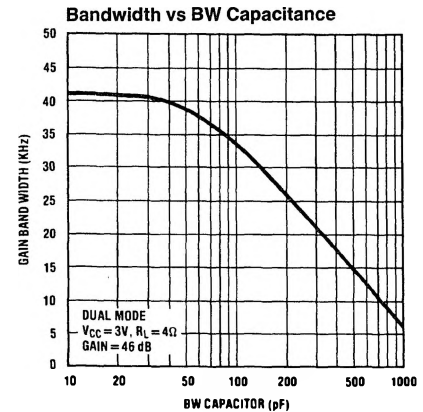
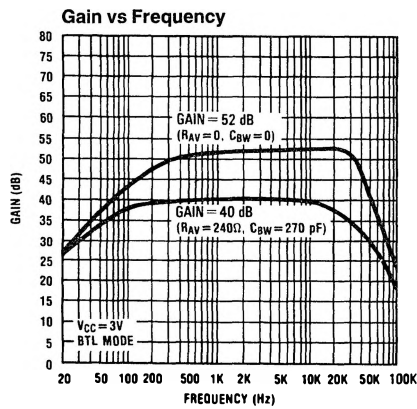
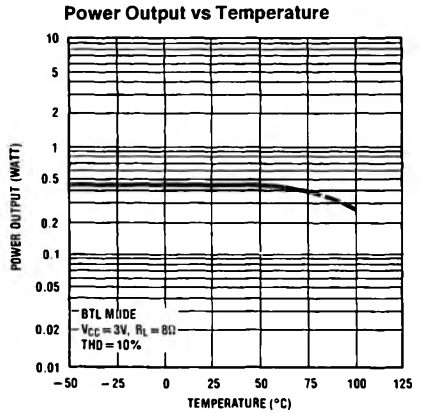
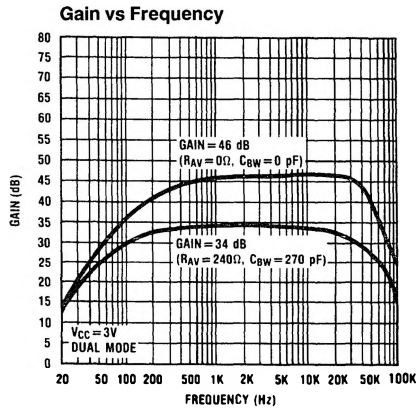
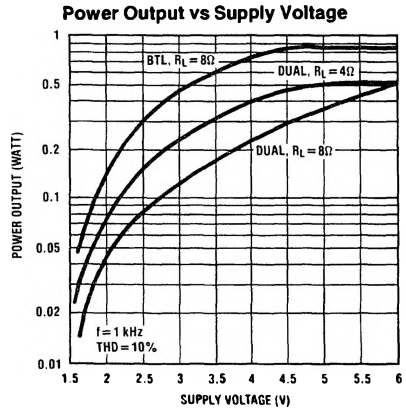
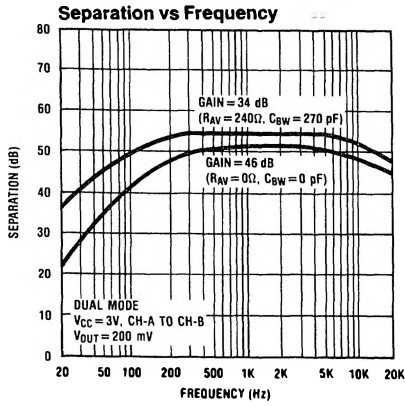

TL/H/6754-5

# Typical Performance Characteristics (Continued)

Dual Mode,  $R_L = 4\Omega$  Distortion vs Frequency

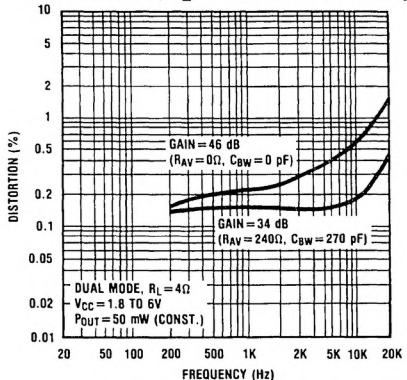

Dual Mode,  $R_L = 8\Omega$  Distortion vs Frequency

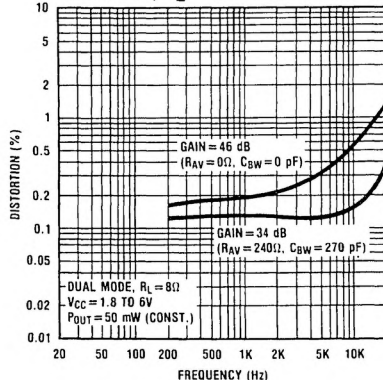

Distortion vs Power Output (Note 2)

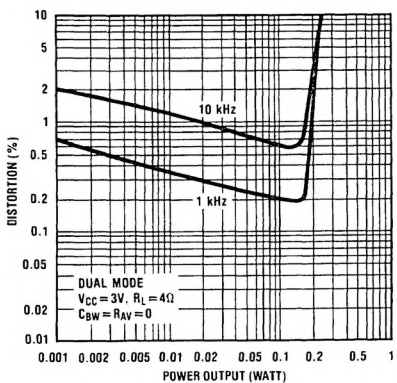

Distortion vs Power Output (Note 2)

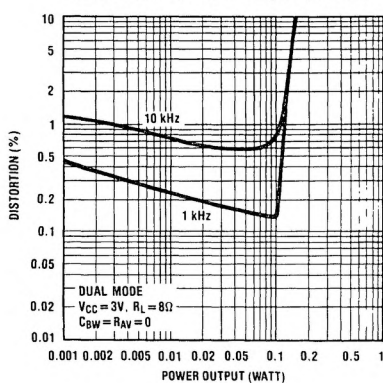

Power Dissipation vs Power Output

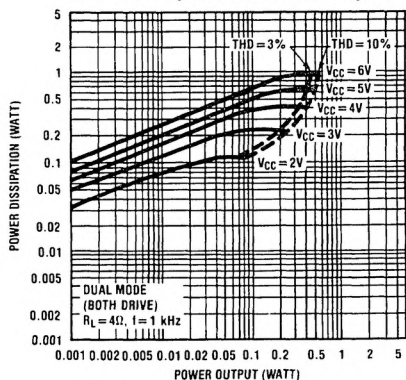

Power Dissipation vs Power Output

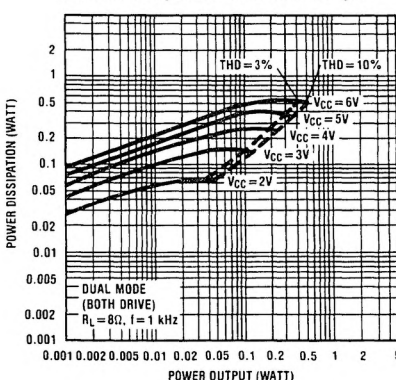

TL/H/6754-6

Typical Performance Characteristics (Continued)

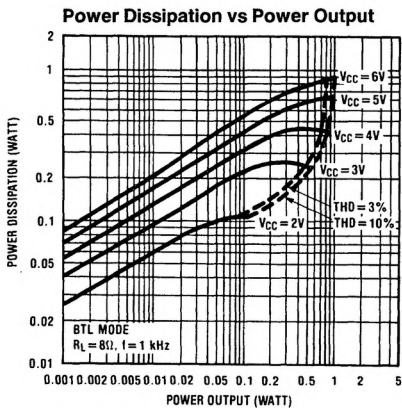
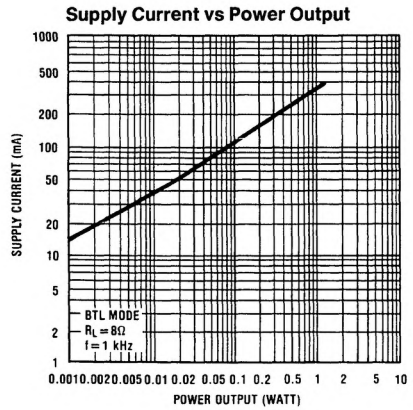
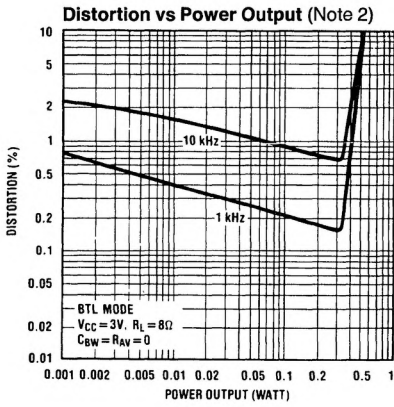
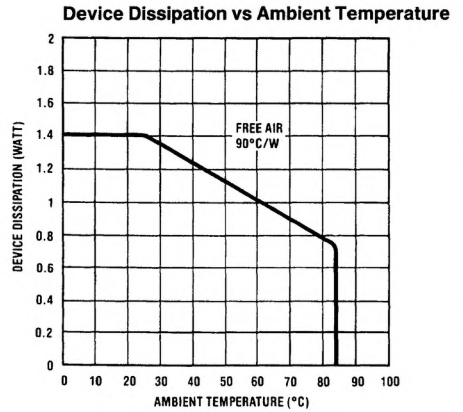
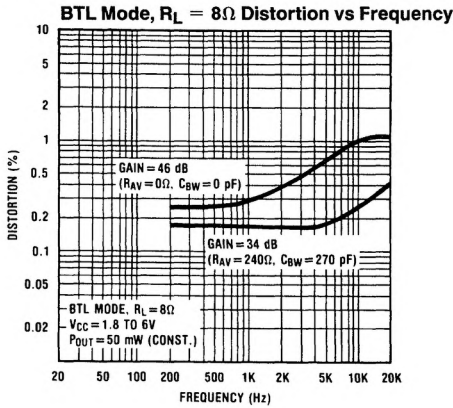

Note 2: 1 kHz curve is measured with 400 Hz–30 kHz Filter.

# Typical Applications

## BTL Amplifier with Minimum Parts

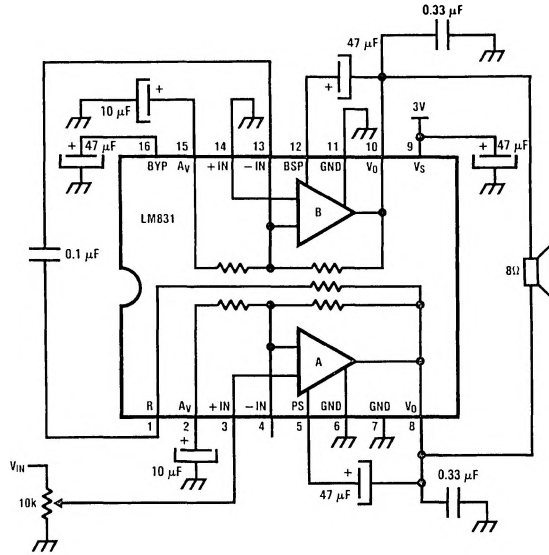

$A_V = 52 \text{ dB}$ ,  $BW = 250 \text{ Hz to } 25 \text{ kHz}$   
 $P_{OUT} = 440 \text{ mW}$ ,  $R_L = 8\Omega$

TL/H/6754-8

## BTL Amplifier for Hi-Fi Quality

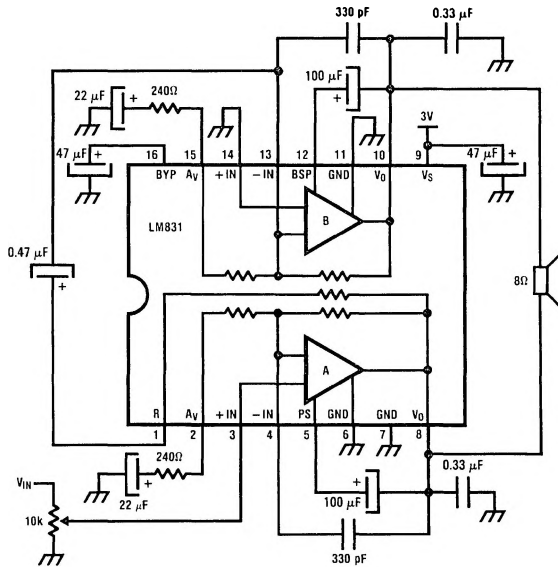

$A_V = 40 \text{ dB}$ ,  $BW = 20 \text{ Hz to } 20 \text{ kHz}$   
 $P_{OUT} = 440 \text{ mW}$ ,  $R_L = 8\Omega$   
 (Dynamic Range Over 80 dB)

TL/H/6754-9

## Typical Applications (Continued)

### Dual Amplifier for Hi-Fi Quality

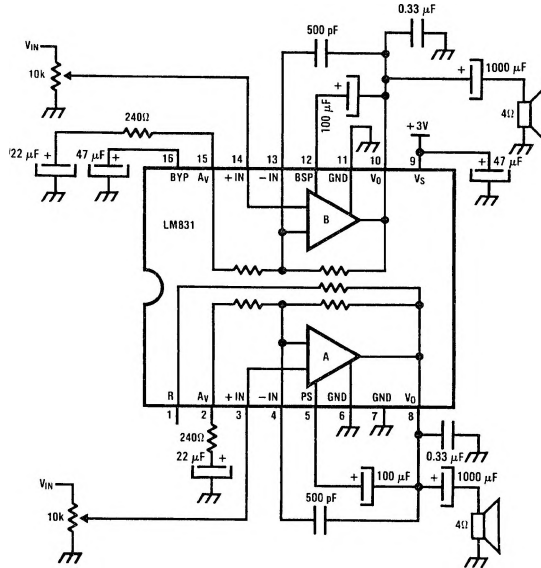

TL/H/6754-10

 $A_V = 34 \text{ dB}$ ,  $BW = 50 \text{ Hz to } 20 \text{ kHz}$ 
 $P_{OUT} = 220 \text{ mW/Ch}$ ,  $R_L = 4\Omega$ 

(Dynamic Range Over 80 dB)

### Low-Cost Power Amplifier (No Bootstrap)

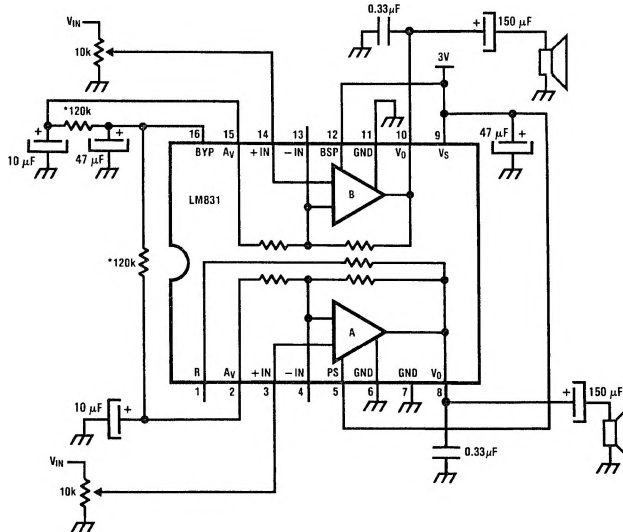

TL/H/6754-11

 $P_{OUT} = 150 \text{ mW/Ch}$ ,  $BW = 300 \text{ Hz to } 35 \text{ kHz}$ 

BTL Mode is also possible

\*For 3-cell applications, the 120k resistor should be changed to 20k.

## LM831 Circuit Description

Refer to the external component diagram and equivalent schematic.

The power supply is applied to Pin 9 and is filtered by resistor  $R_1$  and capacitor  $C_{BY}$  on Pin 16. This filtered voltage at Pin 16 is used to bias all of the LM831 circuits except the power output stage. Resistor  $R_0$  generates a biasing current that sets the output DC voltage for optimum output power for any given supply voltage.

Feedback is provided to the input transistor  $Q_1$  emitter by  $R_6$  and  $R_7$ .

The capacitor  $C_{NF}$  on Pin 2 provides unity DC gain for maximum DC accuracy.

$Q_2$  provides voltage gain and the rest of the devices buffer the output load from  $Q_2$ 's collector.

Bootstrapping of Pin 5 by  $C_{BS}$  allows maximum output swing and improved supply rejection.

$R_5$  is provided for bridge (BTL) operation.

### External Component Diagram

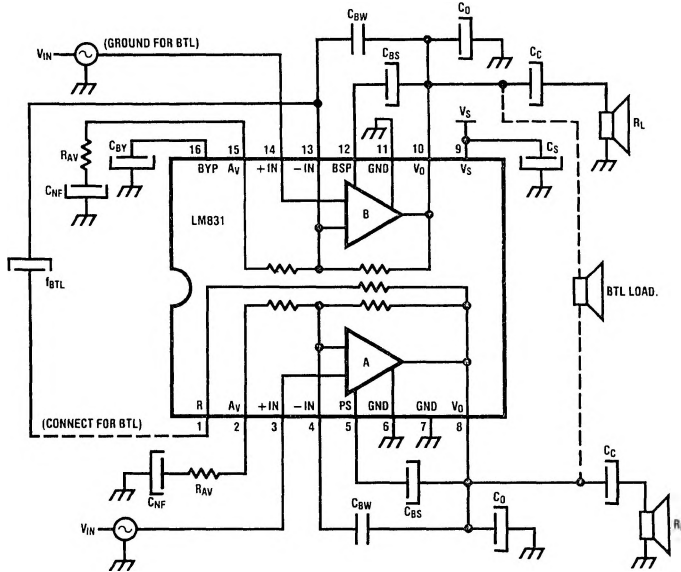

TL/H/6754-12

# LM831 Circuit Description (Continued)

LM831 Equivalent Schematic

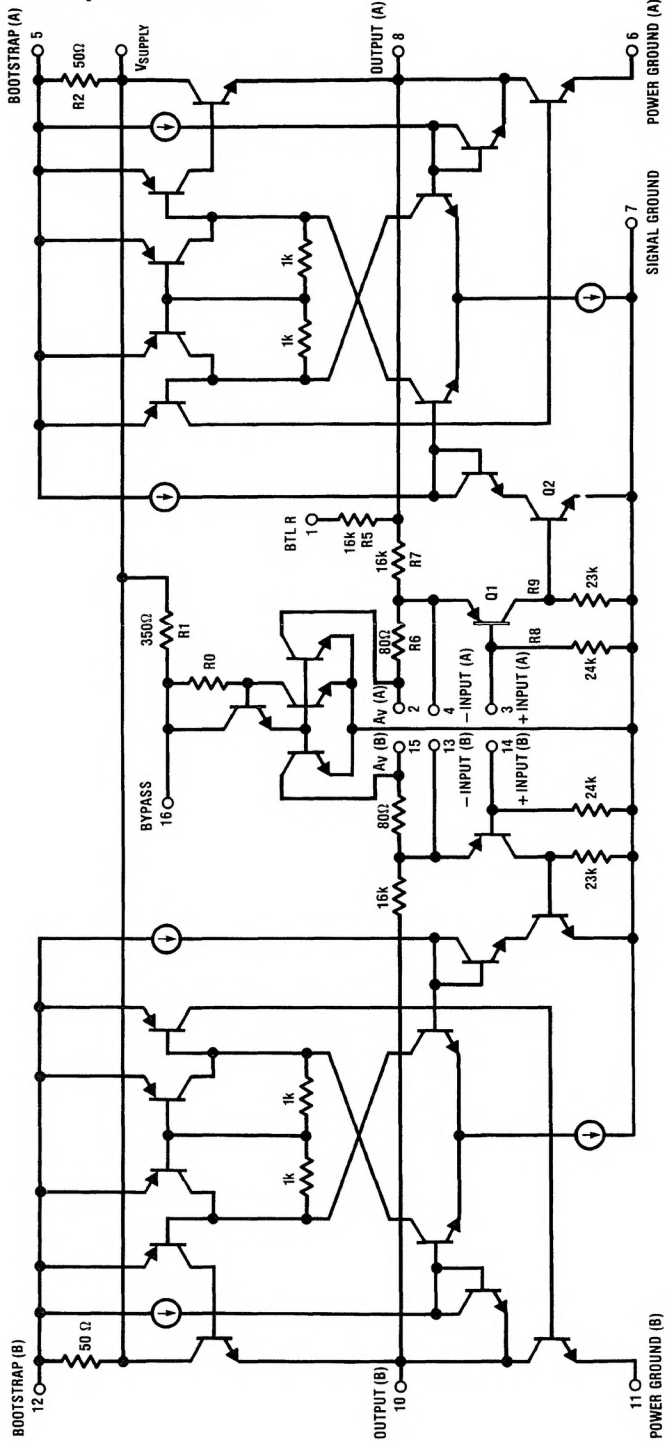

TL/H/6754-13

## External Components (Refer to External Component Diagram)

Component	Comments	Min	Max
C <sub>O</sub>	Required to stabilize output stage.	0.33 μF	1 μF
C <sub>C</sub>	Output coupling capacitors for Dual Mode. Sets a low-frequency pole in the frequency response. $f_L = \frac{1}{2\pi C_C R_L}$	100 μF	10,000 μF
C <sub>BS</sub>	Bootstrap capacitors. Sets a low-frequency pole in the power BW. Recommended value is $C_{BS} = \frac{1}{10 \cdot 2\pi \cdot f_L \cdot R_L}$	22 μF or (short Pins 4 & 12 to 9)	470 μF
C <sub>S</sub>	Supply bypass. Larger values improve low-battery performance by reducing supply ripple.	47 μF	10,000 μF
C <sub>BY</sub>	Filters the supply for improved low-voltage operation. Also sets turn-on delay.	47 μF	470 μF
C <sub>NF</sub>	Sets a low-frequency response. Also affects turn-on delay. $f_L = \frac{1}{2\pi \cdot C_{NF} \cdot (R_{AV} + 80)}$ In BTL Mode, C <sub>NF</sub> on Pin 15 can be reduced without affecting the frequency response. However, the turn-on "POP" will be worsened.	10 μF	100 μF
C <sub>BTL</sub>	Used only in the Bridge Mode. Connects the output of the first amplifier to the inverting input of the other through an internal resistor. Sets a low-frequency pole in one-half the frequency response. $f_L = \frac{1}{2\pi \cdot C_{BTL} \cdot 16k}$	0.1 μF	1 μF
C <sub>BW</sub>	Improves clipping waveform and sets the high-frequency bandwidth. Works with an internal 16k resistor. (This equation applies for R <sub>AV</sub> ≠ 0. For 46 dB application, see BW-C <sub>BW</sub> curve.) $f_H = \frac{1}{2\pi \cdot C_{BW} \cdot 16k}$	See table below	
R <sub>AV</sub>	Used to reduce the gain and improve the distortion and signal to noise. If this is desired, C <sub>BW</sub> must also be used.	See table below	

Typical A <sub>v</sub>	R <sub>AV</sub>	C <sub>BW</sub>	
		Min	Max
46 dB	Short	Open	4700 pF
40 dB	82	100 pF	4700 pF
34 dB	240	270 pF	4700 pF
28 dB	560	500 pF	4700 pF

# Printed Circuit Layout for LM831N (Foil Side View) Refer to External Component Diagram

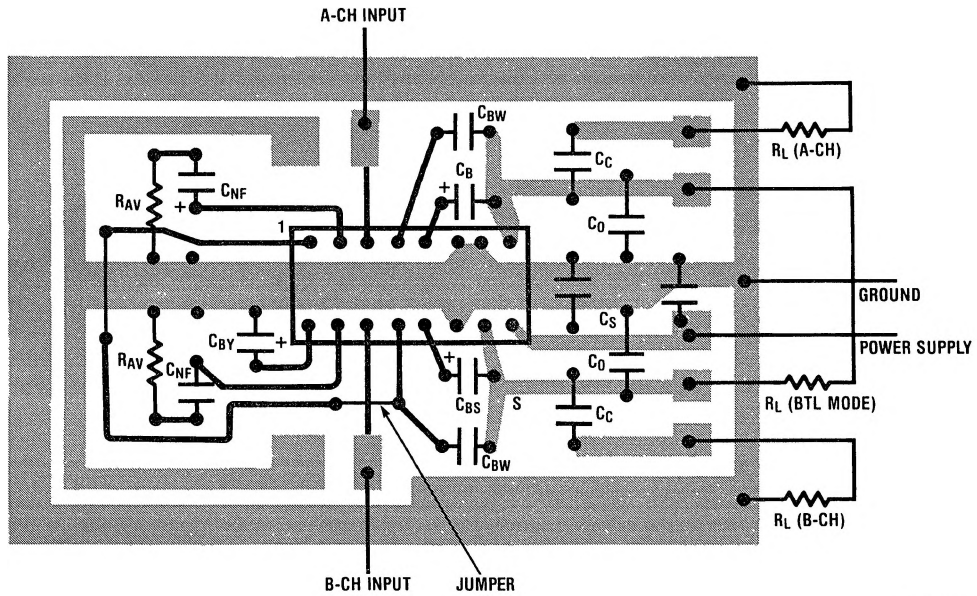

TL/H/6754-14

**Note:** Power ground pattern should be as wide as possible. Supply bypass capacitor should be as close to the IC as possible. Output compensation capacitors should also be close to the IC.