



LM79XX Series 3-Terminal Negative Regulators

General Description

The LM79XX series of 3-terminal regulators is available with fixed output voltages of $-5V$, $-8V$, $-12V$, and $-15V$. These devices need only one external component—a compensation capacitor at the output. The LM79XX series is packaged in the TO-220 power package and is capable of supplying 1.5A of output current.

These regulators employ internal current limiting safe area protection and thermal shutdown for protection against virtually all overload conditions.

Low ground pin current of the LM79XX series allows output voltage to be easily boosted above the preset value with a resistor divider. The low quiescent current drain of

these devices with a specified maximum change with line and load ensures good regulation in the voltage boosted mode.

For applications requiring other voltages, see LM137 data sheet.

Features

- Thermal, short circuit and safe area protection
- High ripple rejection
- 1.5A output current
- 4% tolerance on preset output voltage

Connection Diagrams

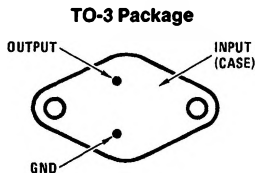

TL/H/7340-10

Bottom View

Order Number LM7905CK, LM7908CK, LM7912CK or LM7915CK
See NS Package Number KC02A

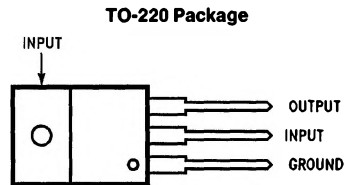

TL/H/7340-14

Front View

Order Number LM7905CT, LM7908CT, LM7912CT or LM7915CT
See NS Package Number TO3B

Typical Applications

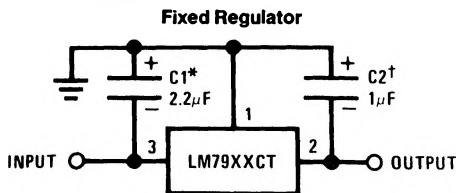

TL/H/7340-3

*Required if regulator is separated from filter capacitor by more than 3". For value given, capacitor must be solid tantalum. 25 μ F aluminum electrolytic may be substituted.

†Required for stability. For value given, capacitor must be solid tantalum. 25 μ F aluminum electrolytic may be substituted. Values given may be increased without limit.

For output capacitance in excess of 100 μ F, a high current diode from input to output (1N4001, etc.) will protect the regulator from momentary input shorts.

Absolute Maximum Ratings (Note 1)

If Military/Aerospace specified devices are required, please contact the National Semiconductor Sales Office/Distributors for availability and specifications.

Input Voltage	
($V_o = -5V$)	-25V
($V_o = -8V, -12V, \text{ and } -15V$)	-35V

Input-Output Differential	25V
($V_o = -5V$)	30V
($V_o = -8V, -12V \text{ - and } 15V$)	
Power Dissipation (Note 2)	Internally Limited
Operating Junction Temperature Range	0°C to +125°C
Storage Temperature Range	-65°C to +150°C
Lead Temperature (Soldering, 10 sec.)	230°C

Electrical Characteristics Conditions unless otherwise noted: $I_{OUT} = 500 \text{ mA}$, $C_{IN} = 2.2 \mu\text{F}$, $C_{OUT} = 1 \mu\text{F}$, $0^\circ\text{C} \leq T_J \leq +125^\circ\text{C}$, Power Dissipation $\leq 1.5\text{W}$.

Part Number			LM7905C			LM7908C			Units	
Output Voltage			-5V			-8V				
Input Voltage (unless otherwise specified)			-10V			-14V				
Symbol	Parameter	Conditions	Min	Typ	Max	Min	Typ	Max		
V_O	Output Voltage	$T_J = 25^\circ\text{C}$	-4.8	-5.0	-5.2	-7.7	-8.0	-8.3	V	
		$5 \text{ mA} \leq I_{OUT} \leq 1 \text{ A}$,	-4.75		-5.25	-7.6		-8.4	V	
		$P \leq 15\text{W}$	$(-20 \leq V_{IN} \leq -7)$		$(-23 \leq V_{IN} \leq -10.5)$				V	
ΔV_O	Line Regulation	$T_J = 25^\circ\text{C}$, (Note 3)		8	50		5	80	mV	
				$(-25 \leq V_{IN} \leq -7)$		$(-25 \leq V_{IN} \leq -10.5)$				V
				2	15		3	30	mV	
				$(-12 \leq V_{IN} \leq -8)$		$(-17 \leq V_{IN} \leq -11)$				V
ΔV_O	Load Regulation	$T_J = 25^\circ\text{C}$, (Note 3) $5 \text{ mA} \leq I_{OUT} \leq 1.5 \text{ A}$ $250 \text{ mA} \leq I_{OUT} \leq 750 \text{ mA}$		15	100		15	200	mV	
				5	50		5	75	mV	
I_Q	Quiescent Current	$T_J = 25^\circ\text{C}$		1	2		1.5	3	mA	
ΔI_Q	Quiescent Current Change	With Line			0.5			0.5	mA	
		With Load, $5 \text{ mA} \leq I_{OUT} \leq 1 \text{ A}$			0.5			0.5	mA	
V_n	Output Noise Voltage	$T_A = 25^\circ\text{C}$, $10 \text{ Hz} \leq f \leq 100 \text{ Hz}$		125			200		μV	
	Ripple Rejection	$f = 120 \text{ Hz}$	54	66		54	60		dB	
			$(-18 \leq V_{IN} \leq -8)$		$(-21 \leq V_{IN} \leq -11)$				V	
	Dropout Voltage	$T_J = 25^\circ\text{C}$, $I_{OUT} = 1 \text{ A}$		1.1			1.1		V	
I_{OMAX}	Peak Output Current	$T_J = 25^\circ\text{C}$		2.2			2.2		A	
	Average Temperature Coefficient of Output Voltage	$I_{OUT} = 5 \text{ mA}$, $0^\circ\text{C} \leq T_J \leq 100^\circ\text{C}$		0.4			-0.6		mV/°C	

Typical Applications (Continued)

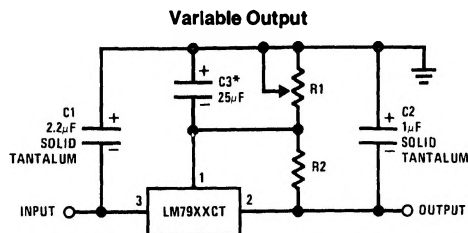

TL/H/7340-2

*Improves transient response and ripple rejection. Do not increase beyond 50 μF .

$$V_{OUT} = V_{SET} \left(\frac{R1 + R2}{R2} \right)$$

Select R2 as follows:

LM7905CT	300 Ω
LM7908CT	500 Ω
LM7912CT	750 Ω
LM7915CT	1k

Electrical Characteristics (Continued)

Conditions unless otherwise noted: $I_{OUT} = 500 \text{ mA}$, $C_{IN} = 2.2 \mu\text{F}$, $C_{OUT} = 1 \mu\text{F}$, $0^\circ\text{C} \leq T_J \leq +125^\circ\text{C}$, Power Dissipation = 1.5W.

Part Number			LM7912C			LM7915C			Units
Output Voltage			-12V			-15V			
Input Voltage (unless otherwise specified)			-19V			-23V			
Symbol	Parameter	Conditions	Min	Typ	Max	Min	Typ	Max	
V_O	Output Voltage	$T_J = 25^\circ\text{C}$ $5 \text{ mA} \leq I_{OUT} \leq 1 \text{ A}$, $P \leq 15\text{W}$	-11.5	-12.0	-12.5	-14.4	-15.0	-15.6	V
			-11.4		-12.6	-14.25		-15.75	V
			$(-27 \leq V_{IN} \leq -14.5)$			$(-30 \leq V_{IN} \leq -17.5)$			V
ΔV_O	Line Regulation	$T_J = 25^\circ\text{C}$, (Note 3)	5	80		5	100		mV
			$(-30 \leq V_{IN} \leq -14.5)$			$(-30 \leq V_{IN} \leq -17.5)$			V
			3	30		3	50		mV
			$(-22 \leq V_{IN} \leq -16)$			$(-26 \leq V_{IN} \leq -20)$			V
ΔV_O	Load Regulation	$T_J = 25^\circ\text{C}$, (Note 3) $5 \text{ mA} \leq I_{OUT} \leq 1.5 \text{ A}$ $250 \text{ mA} \leq I_{OUT} \leq 750 \text{ mA}$	15	200		15	200		mV
			5	75		5	75		mV
I_Q	Quiescent Current	$T_J = 25^\circ\text{C}$	1.5	3		1.5	3		mA
ΔI_Q	Quiescent Current Change	With Line		0.5			0.5		mA
		With Load, $5 \text{ mA} \leq I_{OUT} \leq 1 \text{ A}$		0.5			0.5		mA
V_n	Output Noise Voltage	$T_A = 25^\circ\text{C}$, $10 \text{ Hz} \leq f \leq 100 \text{ Hz}$	300			375			μV
	Ripple Rejection	$f = 120 \text{ Hz}$	54	70		54	70		dB
			$(-25 \leq V_{IN} \leq -15)$			$(-30 \leq V_{IN} \leq -17.5)$			V
	Dropout Voltage	$T_J = 25^\circ\text{C}$, $I_{OUT} = 1 \text{ A}$	1.1			1.1			V
I_{OMAX}	Peak Output Current	$T_J = 25^\circ\text{C}$	2.2			2.2			A
	Average Temperature Coefficient of Output Voltage	$I_{OUT} = 5 \text{ mA}$, $0^\circ\text{C} \leq T_J \leq 100^\circ\text{C}$	-0.8			-1.0			$\text{mV}/^\circ\text{C}$

Note 1: Absolute Maximum Ratings indicate limits beyond which damage to the device may occur. Operating Ratings indicate conditions for which the device is intended to be functional, but do not guarantee Specific Performance limits. For guaranteed specifications and test conditions, see the Electrical Characteristics.

Note 2: Refer to Typical Performance Characteristics and Design Considerations for details.

Note 3: Regulation is measured at a constant junction temperature by pulse testing with a low duty cycle. Changes in output voltage due to heating effects must be taken into account.

Typical Applications (Continued)

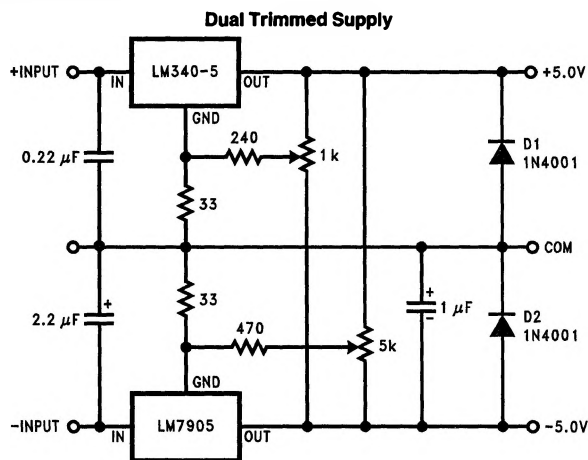

TL/H/7340-4

Design Considerations

The LM79XX fixed voltage regulator series has thermal overload protection from excessive power dissipation, internal short circuit protection which limits the circuit's maximum current, and output transistor safe-area compensation for reducing the output current as the voltage across the pass transistor is increased.

Although the internal power dissipation is limited, the junction temperature must be kept below the maximum specified temperature (125°C) in order to meet data sheet specifications. To calculate the maximum junction temperature or heat sink required, the following thermal resistance values should be used:

Package	Typ θ_{JC} °C/W	Max θ_{JC} °C/W	Typ θ_{JA} °C/W	Max θ_{JA} °C/W
TO-3	3.5	5.5	40	35
TO-220	3.0	5.0	60	40

$$P_{D\text{ MAX}} = \frac{T_{J\text{ MAX}} - T_A}{\theta_{JC} + \theta_{CA}} \text{ or } \frac{T_{J\text{ MAX}} - T_A}{\theta_{JA}}$$

$$\theta_{CA} = \theta_{CS} + \theta_{SA} \text{ (without heat sink)}$$

Solving for T_J :

$$T_J = T_A + P_D (\theta_{JC} + \theta_{CA}) \text{ or}$$

$$= T_A + P_D \theta_{JA} \text{ (without heat sink)}$$

Where:

T_J = Junction Temperature

T_A = Ambient Temperature

P_D = Power Dissipation

θ_{JA} = Junction-to-Ambient Thermal Resistance

θ_{JC} = Junction-to-Case Thermal Resistance

θ_{CA} = Case-to-Ambient Thermal Resistance

θ_{CS} = Case-to-Heat Sink Thermal Resistance

θ_{SA} = Heat Sink-to-Ambient Thermal Resistance

Typical Applications (Continued)

Bypass capacitors are necessary for stable operation of the LM79XX series of regulators over the input voltage and output current ranges. Output bypass capacitors will improve the transient response by the regulator.

The bypass capacitors, (2.2 μF on the input, 1.0 μF on the output) should be ceramic or solid tantalum which have good high frequency characteristics. If aluminum electrolytics are used, their values should be 10 μF or larger. The bypass capacitors should be mounted with the shortest leads, and if possible, directly across the regulator terminals.

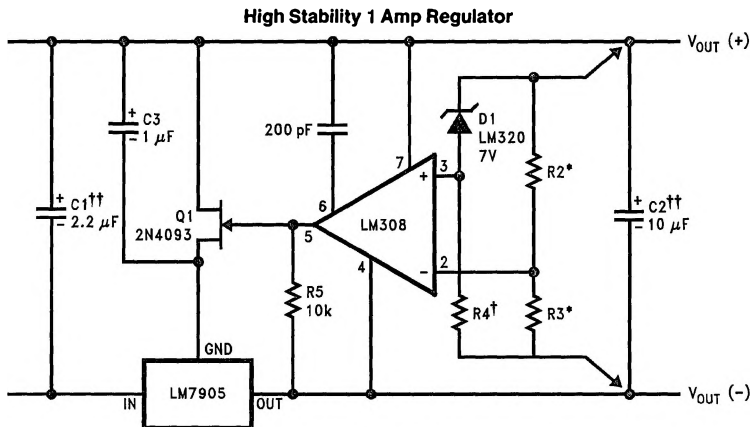

TL/H/7340-5

Load and line regulation < 0.01% temperature stability \leq 0.2%

†Determine Zener current

††Solid tantalum

*Select resistors to set output voltage. 2 ppm/°C tracking suggested

Typical Applications (Continued)

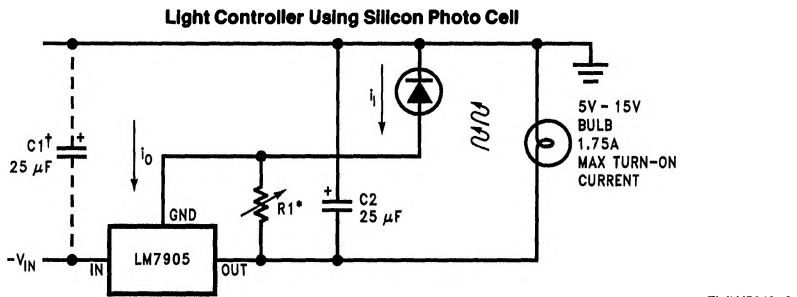
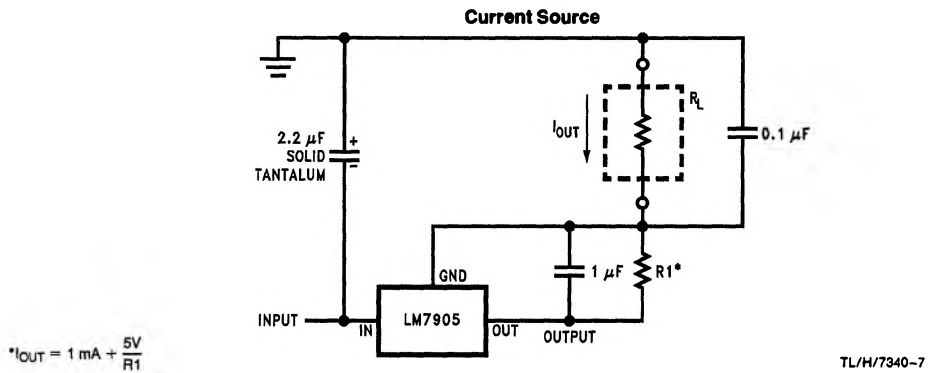

*Lamp brightness increase until $I_1 = I_0 (\approx 1 \text{ mA}) + 5V/R1$.

†Necessary only if raw supply filter capacitor is more than 2" from LM7905CT

Typical Applications (Continued)

High-Sensitivity Light Controller

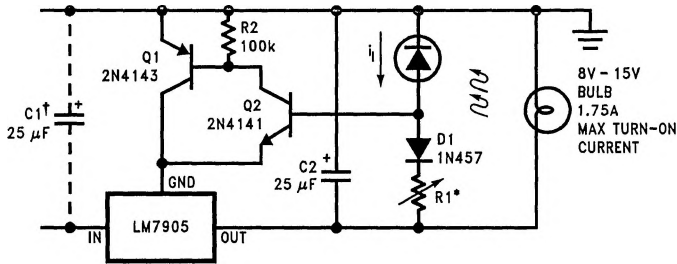

TL/H/7340-9

*Lamp brightness increases until $i_i = 5V/R1$ (i_i can be set as low as $1 \mu A$)

†Necessary only if raw supply filter capacitor is more than 2" from LM7905

± 15V, 1 Amp Tracking Regulators

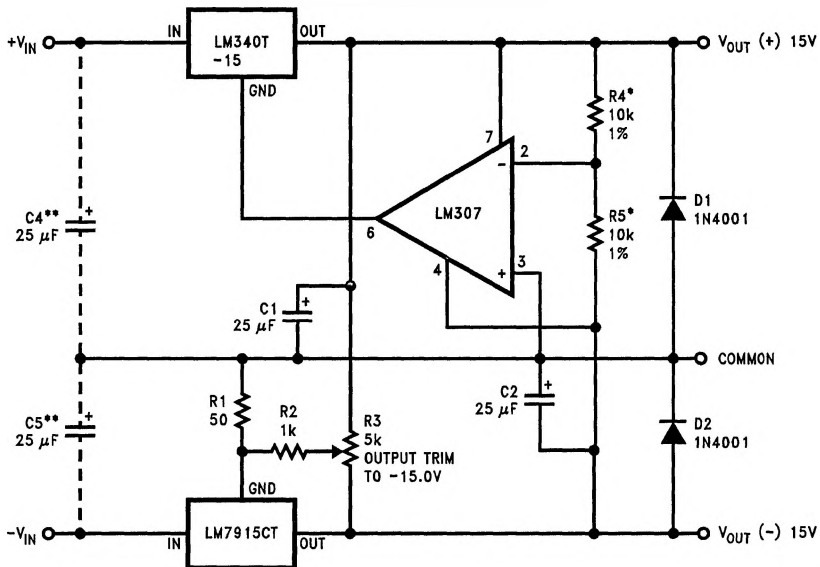

TL/H/7340-1

	(-15)	(+15)
Load Regulation at $\Delta I_L = 1A$	40 mV	2 mV
Output Ripple, $C_{IN} = 3000 \mu F, I_L = 1A$	100 μV_{rms}	100 μV_{rms}
Temperature Stability	50 mV	50 mV
Output Noise 10 Hz $\leq f \leq 10$ kHz	150 μV_{rms}	150 μV_{rms}

*Resistor tolerance of R4 and R5 determine matching of (+) and (-) outputs.

**Necessary only if raw supply filter capacitors are more than 3" from regulators.

Schematic Diagrams

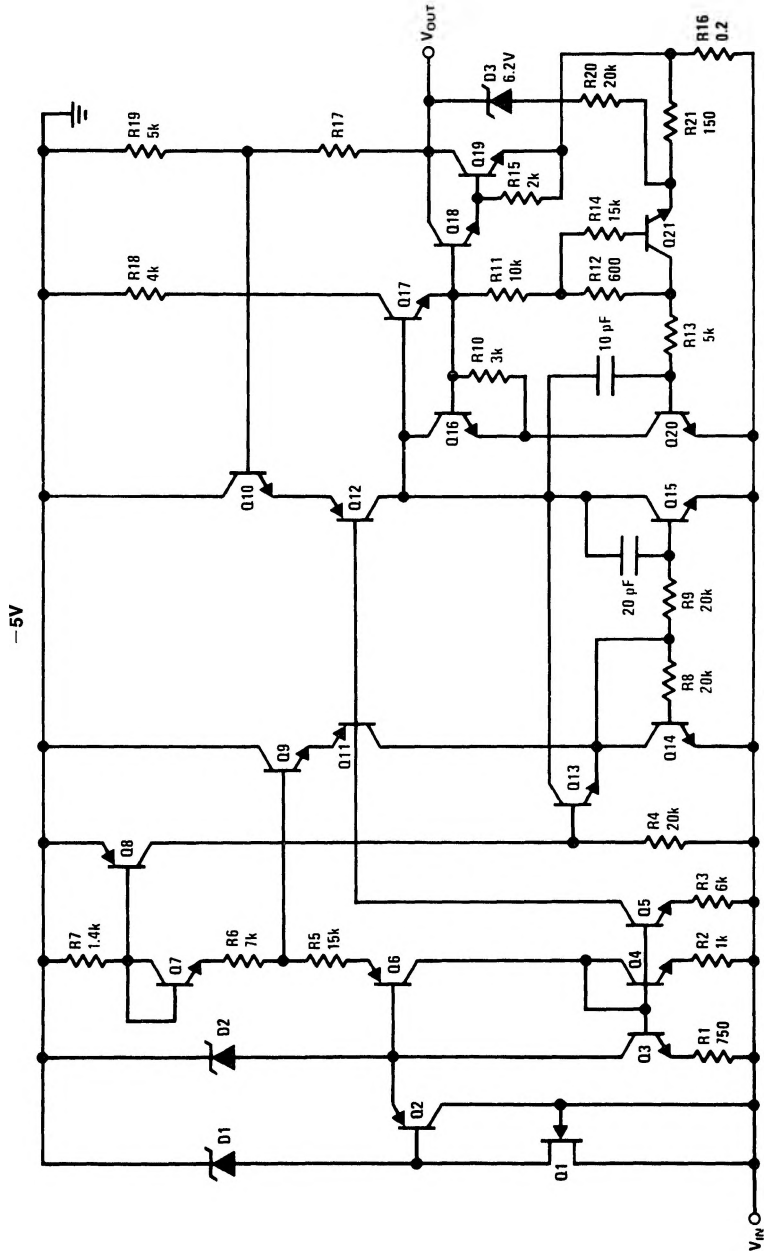

Schematic Diagrams (Continued)

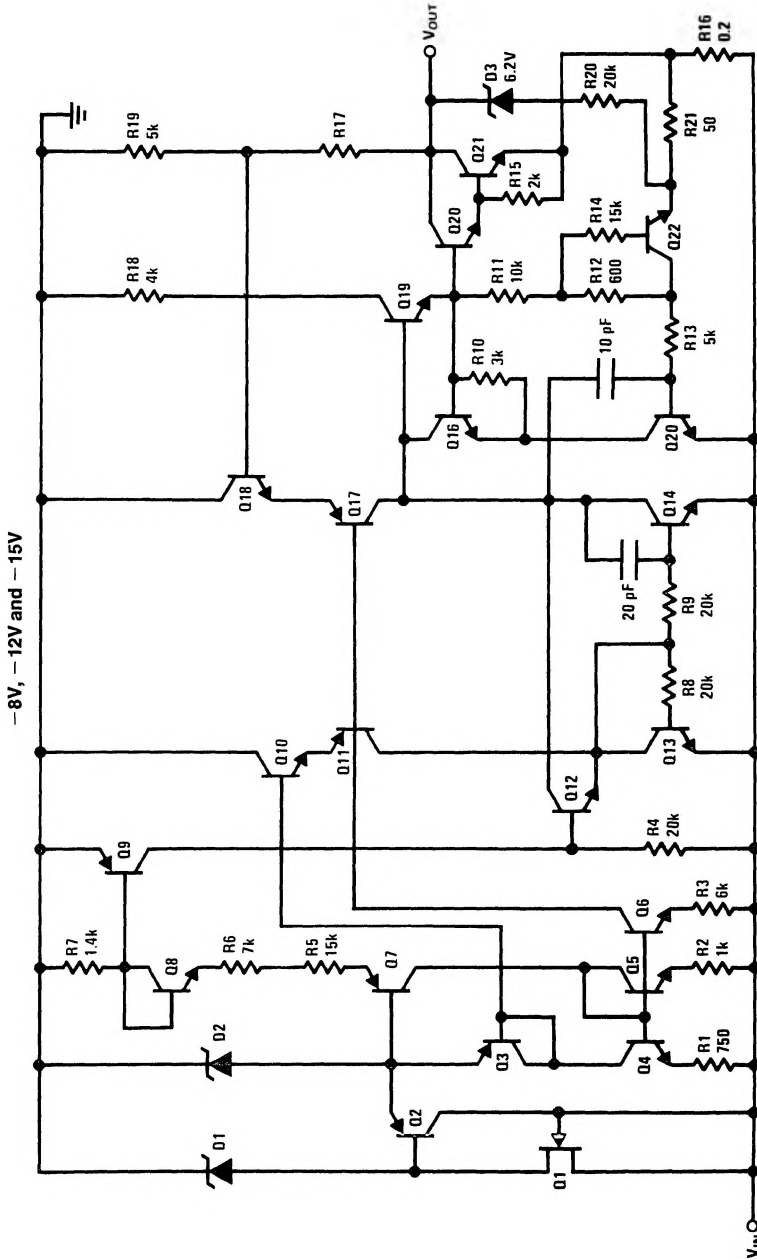

TL/H/7340-13

LM79XX