



LM78MG/LM79MG 4-Terminal Adjustable Voltage Regulators

General Description

The LM78MG and LM79MG are 4-terminal adjustable voltage regulators. They are designed to deliver continuous load currents of up to 500 mA with a maximum input voltage of +40V for the positive regulator LM78MG and -40V for the negative regulator LM79MG. Output current capability can be increased to greater than 10A through use of one or more external transistors. The output voltage range of the LM78MG positive voltage regulator is 5.0V to 30V and the output voltage range of the negative LM79MG is -30V to -2.2V. For systems requiring both a positive and negative, the LM78MG and LM79MG are excellent for use as a dual tracking regulator.

Features

- Output current in excess of 0.5A
- LM78MG positive output voltage +5.0V to +30V
- LM79MG negative output voltage -30V to -2.2V
- Internal thermal overload protection
- Internal short circuit current protection
- Output transistor safe-area protection

Connection Diagrams

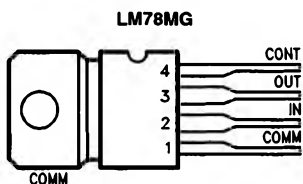

TL/H/10058-1

Top View

Heat sink tabs connected to input through device substrate. Not recommended for direct electrical connection.

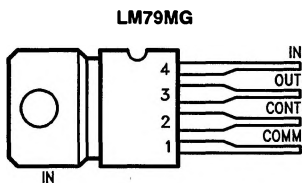

TL/H/10058-2

Top View

Heat sink tabs connected to input through device substrate. Not recommended for direct electrical connection.

Ordering Information

Device Code	Package Code	Package Description
LM78MGCT	P04A	Molded 4-Lead TO-202
LM79MGCT	P04A	Molded 4-Lead TO-202

Absolute Maximum Ratings

If Military/Aerospace specified devices are required, please contact the National Semiconductor Sales Office/Distributors for availability and specifications.

Storage Temperature Range -65°C to $+150^{\circ}\text{C}$
 Operating Junction Temperature
 Range 0°C to $+150^{\circ}\text{C}$
 Lead Temperature (Soldering, 10 sec.) 265°C
 Internal Power Dissipation Internally Limited

Input Voltage
 LM78MGC $+40\text{V}$
 -40V
 Control Lead Voltage
 LM78MGC $0\text{V} \leq V^+ \leq V_O$
 LM79MGC $V_O^- \leq V^- \leq 0\text{V}$

LM78MGC

Electrical Characteristics $0^{\circ}\text{C} \leq T_A \leq 125^{\circ}\text{C}$ for LM78MGC, $V_I = 10\text{V}$, $I_O = 350\text{ mA}$, $C_I = 0.33\ \mu\text{F}$, $C_O = 0.1\ \mu\text{F}$, Test Circuit 1, unless otherwise specified

Symbol	Parameter	Conditions (Notes 1, 3)	Min	Typ	Max	Units
V_{IR}	Input Voltage Range	$T_J = 25^{\circ}\text{C}$	7.5		40	V
V_{OR}	Output Voltage Range	$V_I = V_O + 5.0\text{V}$	5.0		30	V
V_O	Output Voltage Tolerance	$(V_O + 3.0\text{V}) \leq V_I \leq (V_O + 15\text{V})$, $5.0\text{ mA} \leq I_O \leq 350\text{ mA}$, $P_D \leq 5.0\text{W}$, $V_{I\text{Max}} = 38\text{V}$	$T_J = 25^{\circ}\text{C}$		4.0	% (V_O)
					5.0	
$V_{O\text{LINE}}$	Line Regulation	$T_J = 25^{\circ}\text{C}$, $I_O = 200\text{ mA}$, $V_O \leq 10\text{V}$, $(V_O + 2.5\text{V}) \leq V_I \leq (V_O + 20\text{V})$, $T_J = 25^{\circ}\text{C}$, $I_O = 200\text{ mA}$, $V_O \geq 10\text{V}$			1.0	% (V_O)
$V_{O\text{LOAD}}$	Load Regulation	$T_J = 25^{\circ}\text{C}$, $5.0\text{ mA} \leq I_O \leq 500\text{ mA}$, $V_I = V_O + 7.0\text{V}$			1.0	% (V_O)
I_C	Control Lead Current	$T_J = 25^{\circ}\text{C}$		1.0	6.0	μA
					7.0	
I_Q	Quiescent Current	$T_J = 25^{\circ}\text{C}$		2.8	5.0	mA
					6.0	
RR	Ripple Rejection	$I_O = 125\text{ mA}$, $8.0\text{V} \leq V_I \leq 18\text{V}$, $V_O = 5.0\text{V}$, $f = 2400\text{ Hz}$	62	80		dB
N_O	Output Noise Voltage	$10\text{ Hz} \leq f \leq 100\text{ kHz}$, $V_O = 5.0\text{V}$		8	40	$\mu\text{V}/V_O$
V_{DO}	Dropout Voltage (Note 2)			2	2.5	V
I_{OS}	Short Circuit Current	$V_I = 35\text{V}$, $T_J = 25^{\circ}\text{C}$			600	mA
I_{pk}	Peak Output Current	$T_J = 25^{\circ}\text{C}$	0.4	0.8	1.4	A
$\Delta V_O/\Delta T$	Average Temperature Coefficient of Output Voltage	$V_O = 5.0\text{V}$, $I_O = 5.0\text{ mA}$	$T_A = -55^{\circ}\text{C}$ to $+25^{\circ}\text{C}$		0.4	mV/ $^{\circ}\text{C}/V_O$
			$T_A = 25^{\circ}\text{C}$ to 125°C		0.3	
V_C	Control Lead Voltage (Reference)	$T_J = 25^{\circ}\text{C}$		4.8	5.0	V
				4.75		

LM79MGC

Electrical Characteristics $0^{\circ}\text{C} \leq T_J \leq 125^{\circ}\text{C}$ for LM79MGC, $V_I = -14\text{V}$, $I_O = 350\text{ mA}$, $C_I = 2.0\ \mu\text{F}$,
 $C_O = 1.0\ \mu\text{F}$, Test Circuit 2, unless otherwise specified

Symbol	Parameter	Conditions (Notes 1, 3 & 5)	Min	Typ	Max	Units	
V_{IR}	Input Voltage Range	$T_J = 25^{\circ}\text{C}$	-40		-7.0	V	
V_{OR}	Output Voltage Range	$V_I = V_O - 5.0\text{V}$	-30		-2.23	V	
V_O	Output Voltage Tolerance	$(V_O - 15\text{V}) \leq V_I \leq (V_O - 3.0\text{V})$, $5.0\text{ mA} \leq I_O \leq 350\text{ mA}$, $P_D \leq 5.0\text{W}$, $V_{I\text{ Max}} = -38\text{V}$		$T_J = 25^{\circ}\text{C}$	4.0	% (V_O)	
					5.0		
$V_{O\text{ LINE}}$	Line Regulation	$T_J = 25^{\circ}\text{C}$, $I_O = 200\text{ mA}$, $V_O \leq -10\text{V}$, $(V_O - 20\text{V}) \leq V_I \leq (V_O - 2.5\text{V})$, $T_J = 25^{\circ}\text{C}$, $I_O = 200\text{ mA}$, $V_O \leq -10\text{V}$			1.0	% (V_O)	
$V_{O\text{ LOAD}}$	Load Regulation	$V_I = V_O - 7.0\text{V}$, $5.0\text{ mA} \leq I_O \leq 500\text{ mA}$, $T_J = 25^{\circ}\text{C}$			1.0	% (V_O)	
I_C	Control Lead Current	$T_J = 25^{\circ}\text{C}$			2.0	μA	
					3.0		
I_Q	Quiescent Current	$T_J = 25^{\circ}\text{C}$		0.5	2.5	mA	
					3.5		
RR	Ripple Rejection	$T_J = 25^{\circ}\text{C}$, $I_O = 125\text{ mA}$, $V_I = -13\text{V}$, $V_O = -5.0\text{V}$, $f = 2400\text{ Hz}$	50			dB	
N_O	Noise	$10\text{ Hz} \leq f \leq 100\text{ kHz}$, $V_O = -8.0\text{V}$, $I_L = 50\text{ mA}$		25	80	$\mu\text{V}/V_O$	
V_{DO}	Dropout Voltage			1.1	2.3	V	
I_{OS}	Short Circuit Current	$V_I = 35\text{V}$, $T_J = 25^{\circ}\text{C}$			600	mA	
I_{pk}	Peak Output Current		0.4	0.65	1.4	mA	
$\Delta V_O/\Delta T$	Average Temperature Coefficient of Output Voltage	$V_O = -5.0\text{V}$, $I_O = -5.0\text{ mA}$		$T_A = -55^{\circ}\text{C}$ to $+25^{\circ}\text{C}$		0.3	mV/ $^{\circ}\text{C}/V_O$
				$T_A = 25^{\circ}\text{C}$ to 125°C		0.3	
V_C	Control Lead Voltage (Reference)	$T_J = 25^{\circ}\text{C}$	-2.32	-2.23	-2.14	V	
			-2.35		-2.11		

Note 1: V_O is defined for the LM78MGC as $V_O = \frac{R_1 + R_2}{R_2}(5.0)$; the LM79MGC as $V_O = \frac{R_1 + R_2}{R_2}(-2.23)$.

Note 2: Dropout voltage is defined as that input/output voltage differential which causes the output voltage to decrease by 5% of its initial value.

Note 3: All characteristics except noise voltage and ripple rejection ratio are measured using pulse techniques ($t_W \leq 10\text{ ms}$, duty cycle $\leq 5\%$). Output voltage changes due to changes in internal temperature must be taken into account separately.

Note 4: The convention for negative regulators is the Algebraic value, thus -15V is less than -10V .

LM78MG Equivalent Circuit

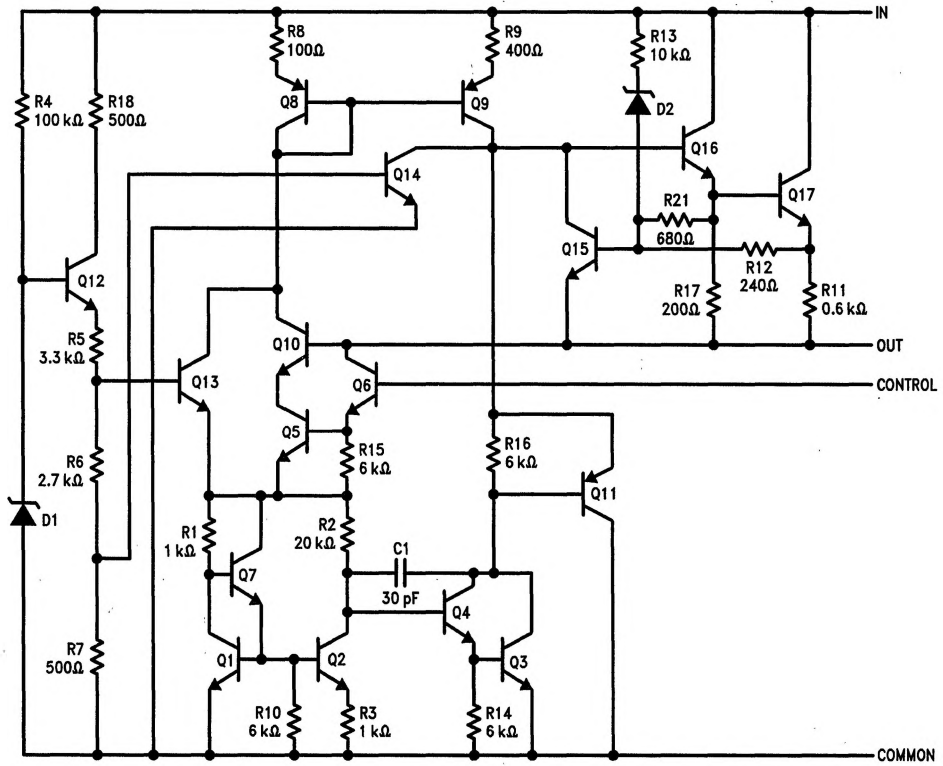

TL/H/10058-3

LM79MG Equivalent Circuit (Note 1)

LM79MG/LM79MG

TL/H/10058-4

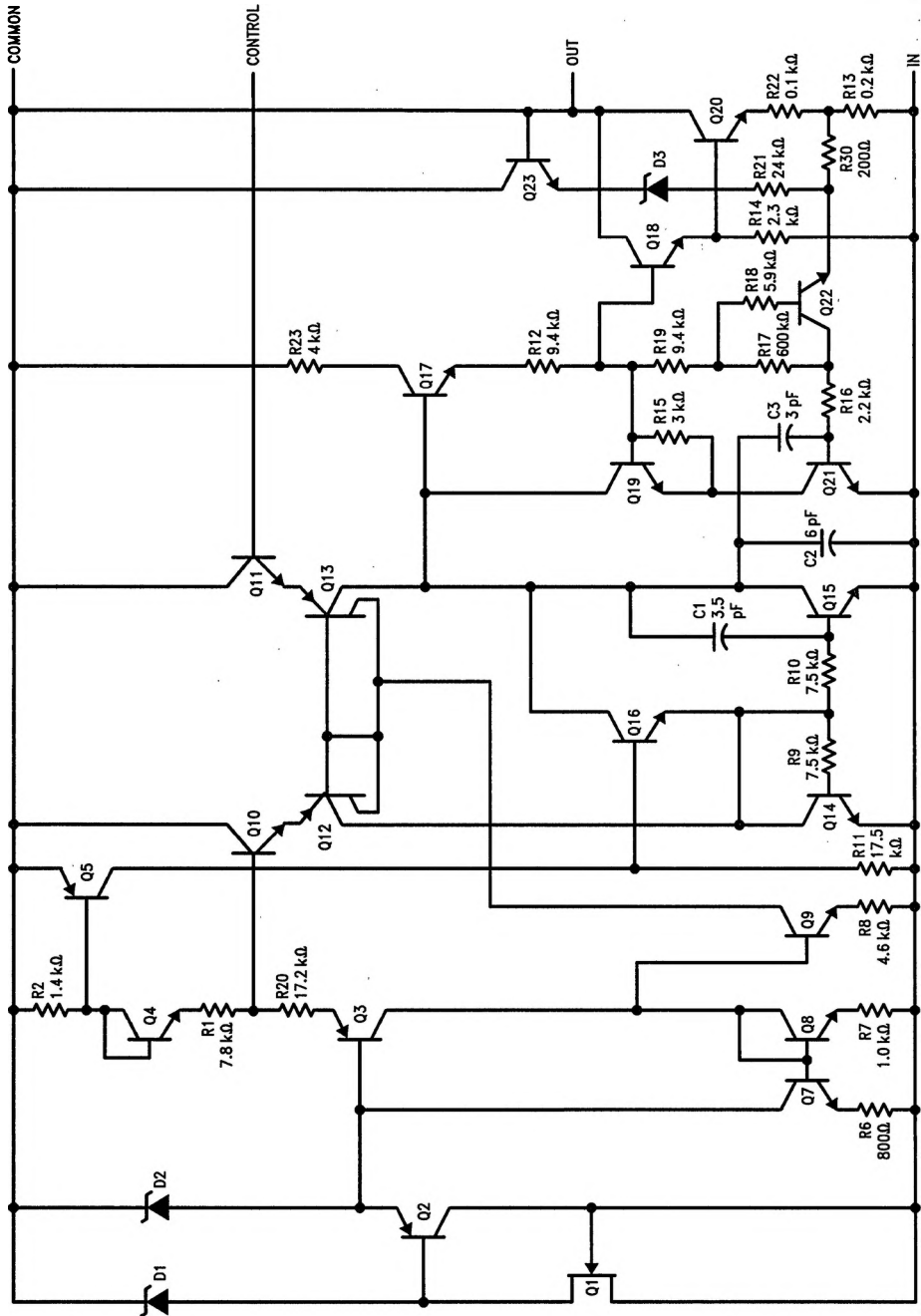

Note 1: Resistor values in Ω , unless otherwise noted.

Design Considerations

The LM78MG and LM79MG variable voltage regulators have an output voltage which varies from V_{CONT} to typically

$$V_I - 2.0V \text{ by } V_O = V_{CONT} \frac{(R1 + R2)}{R2}$$

The nominal reference in the LM78MG is 5.0V and LM79MG is -2.23V. If we allow 1.0 mA to flow in the control swing to eliminate bias current effects, we can make $R2 = 5 \text{ k}\Omega$ in the LM78MG. The output voltage is then: $V_O = (R1 + R2)$ Volts, where $R1$ and $R2$ are in $\text{k}\Omega$ s.

Example: If $R2 = 5.0 \text{ k}\Omega$ and $R1 = 10 \text{ k}\Omega$ then
 $V_O = 15V$ nominal, for the LM78MG;
 $R2 = 2.2 \text{ k}\Omega$ and $R1 = 12.8 \text{ k}\Omega$ then
 $V_O = -15.2V$ nominal, for the LM79MG.

By proper wiring of the feedback resistors, load regulation of the devices can be improved significantly.

Both LM78MG and LM79MG regulators have thermal overload protection from excessive power, internal short circuit protection which limits each circuit's maximum current, and output transistor safe-area protection for reducing the output current as the voltage across each pass transistor is increased.

Although the internal power dissipation is limited, the junction temperature must be kept below the maximum specified temperature in order to meet data sheet specifications. To calculate the maximum junction temperature or heat sink required, the following thermal resistance values should be used:

Package	Typ θ_{JC}	Max θ_{JC}	Typ θ_{JA}	Max θ_{JA}
Power Watt	8.0	12.0	70	75

$$P_{D \text{ Max}} = \frac{T_{J \text{ Max}} - T_A}{\theta_{JC} + \theta_{CA}} \text{ or}$$

$$\frac{T_{J \text{ Max}} - T_A}{\theta_{JA}} \text{ (without a heat sink)}$$

$$\theta_{CA} = \theta_{CS} + \theta_{SA}$$

Solving for T_J :

$$T_J = T_A + P_D(\theta_{JC} + \theta_{CA}) \text{ or}$$

$$T_A + P_D\theta_{JA} \text{ (without heat sink)}$$

Where

T_J = Junction Temperature

T_A = Ambient Temperature

P_D = Power Dissipation

θ_{JC} = Junction-to-Case Thermal Resistance

θ_{CA} = Case-to-Ambient Thermal Resistance

θ_{CS} = Case-to-Heat Sink Thermal Resistance

θ_{SA} = Heat Sink-to-Ambient Thermal Resistance

θ_{JA} = Junction-to-Ambient Thermal Resistance

Typical Applications for

LM78MG (Note 1)

Bypass capacitors are recommended for stable operation of the LM78MG over the input voltage and output current ranges. Output bypass capacitors will improve the transient response of the regulator.

The bypass capacitors, (0.33 μF on the input, 0.1 μF on the output) should be ceramic or solid tantalum which have good high frequency characteristics. The bypass capacitors should be mounted with the shortest leads, and if possible, directly across the regulator terminals.

Note 1: All resistor values in Ohms.

Basic Positive Regulator

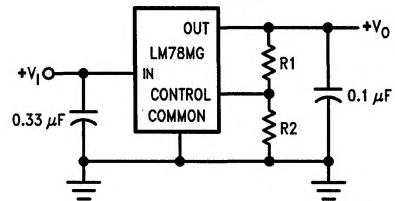

TL/H/10058-8

$$V_O = V_{CONT} \left(\frac{R1 + R2}{R2} \right)$$

Positive 5.0V to 30V Adjustable Regulator

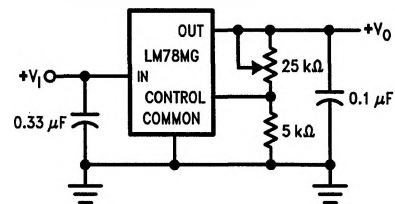

TL/H/10058-9

Positive 5.0V to 30V Adjustable Regulator $I_O > 1.5A$

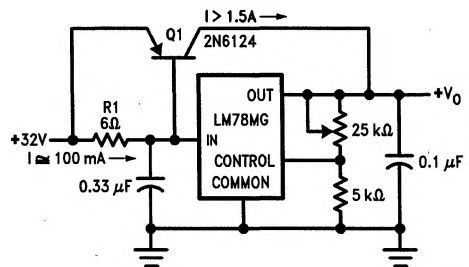

TL/H/10058-10

$$R1 = \frac{\beta V_{BE(Q1)}}{I_{R \text{ Max}}(\beta) - I_O}$$

Typical Applications for LM78MG (Note 1) (Continued)

± 10V, 500 mA Dual Tracking Regulator

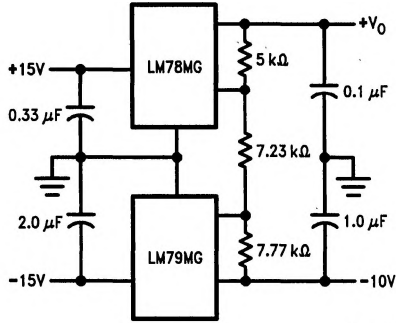

TL/H/10058-11

Positive High-Current Voltage Regulator

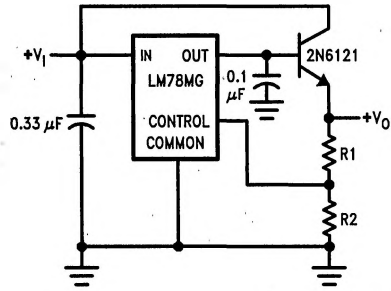

TL/H/10058-12

Note: External series pass device is not short circuit protected.

Positive High Current Short Circuit Protected Regulator

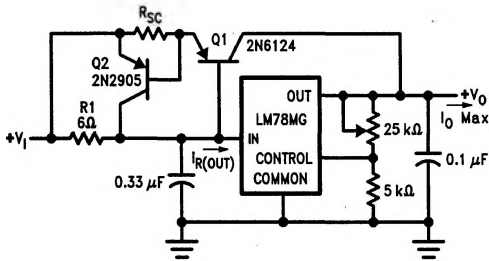

TL/H/10058-14

$$R1 = \frac{\beta V_{BE}(Q1)}{V_{R\ Max}(\beta + 1) - I_{O\ Max}}$$

If load is not ground referenced, connect reverse biased diodes from outputs to ground.

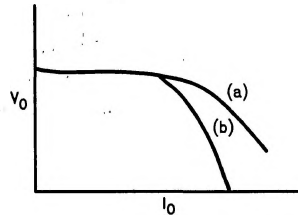

TL/H/10058-13

External Series Pass (a)

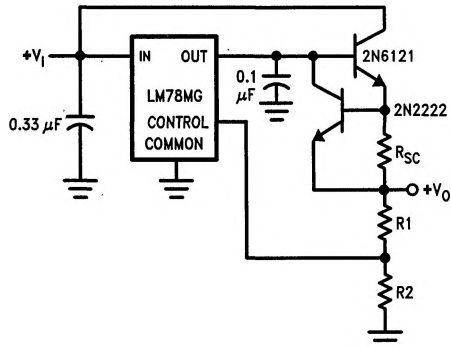

TL/H/10058-15

Short-Circuit Limit (b)

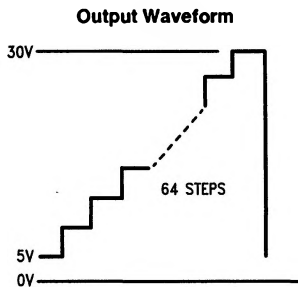

TL/H/10058-16

Note 1: All resistor values in ohms.

Typical Applications for LM79MG (Note 1)

Bypass capacitors are recommended for stable operation of the LM79MG over the input voltage and output current ranges. Output bypass capacitors will improve the transient response of the regulator.

The bypass capacitors, (2.0 μF on the input, 1.0 μF on the output) should be ceramic or solid tantalum which have good high frequency characteristics. If aluminum electrolytics are used, their values should be 10 μF or larger. The bypass capacitors should be mounted with the shortest leads, and if possible, directly across the regulator terminals.

Negative High Current Short Circuit Protected Regulator

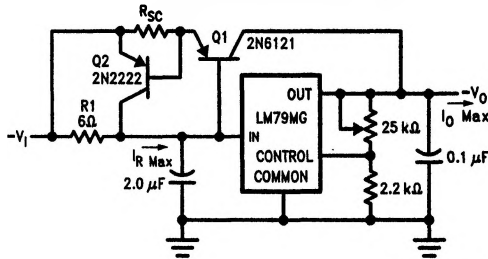

TL/H/10058-17

$$T_1 = \frac{\beta V_{BE}(Q1)}{I_{R \text{ Max}}(\beta) - I_{O \text{ Max}}}$$

Basic Negative Regulator

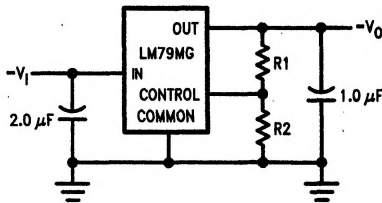

TL/H/10058-19

$$V_o = -V_{\text{CONT}} \left(\frac{R_1 + R_2}{R_2} \right)$$

-30V to -2.2V Adjustable Regulator

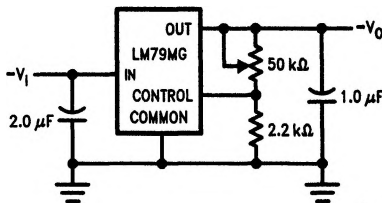

TL/H/10058-21

Note 1: All resistor values in ohms.

Negative High Current Voltage Regulator External Series Pass

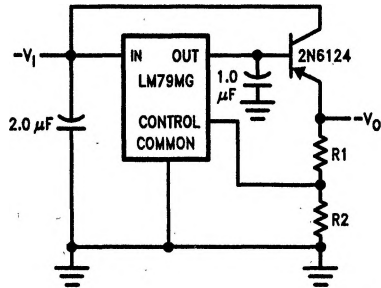

TL/H/10058-18

LM78MG Test Circuit 1

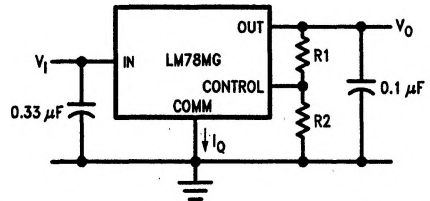

TL/H/10058-20

$$V_o = \left(\frac{R_1 + R_2}{R_2} \right) V_{\text{CONT}}$$

$$V_{\text{CONT}} \text{ Nominally} = 5V$$

LM79MG Test Circuit 2

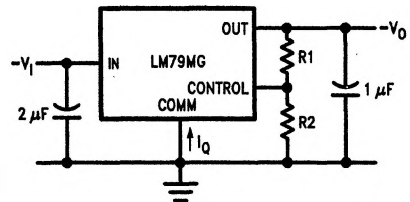

TL/H/10058-22

$$V_o = \left(\frac{R_1 + R_2}{R_2} \right) V_{\text{CONT}}$$

$$V_{\text{CONT}} \text{ Nominally} = -2.23V$$

Recommended R2 current ≈ 1 mA

$$\therefore R_2 = 5 \text{ k}\Omega \text{ (LM78MG)}$$

$$R_2 = 2.2 \text{ k}\Omega \text{ (LM79MG)}$$

Typical Performance Characteristics for LM78MG

Peak Output Current vs Input/Output Differential Voltage

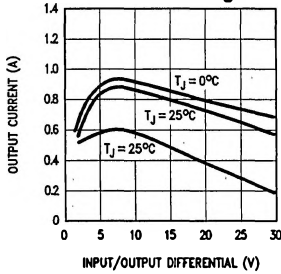

Quiescent Current vs Input Voltage

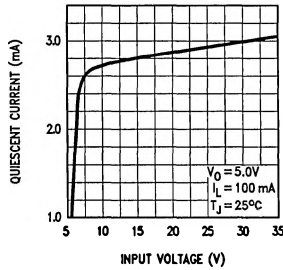

Control Current vs Temperature

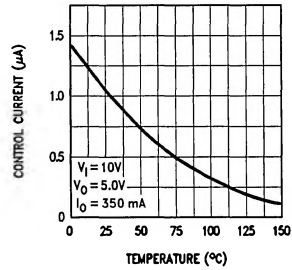

Differential Control Voltage vs Input Voltage

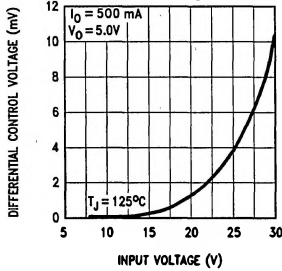

Differential Control Voltage vs Output Current

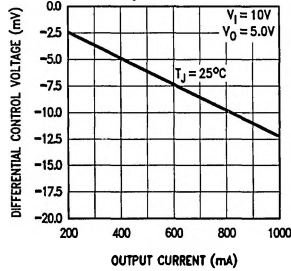

Ripple Rejection vs Output Voltage

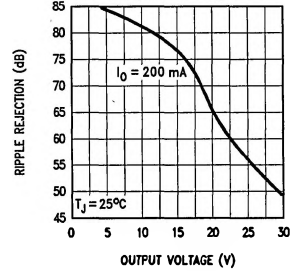

Dropout Voltage vs Junction Temperature

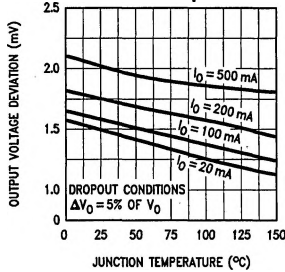

Ripple Rejection vs Frequency

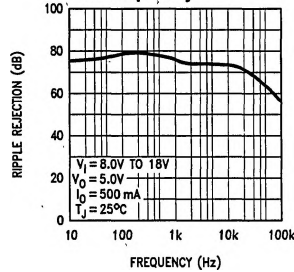

Load Transient Response

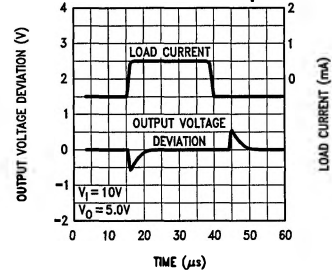

Line Transient Response

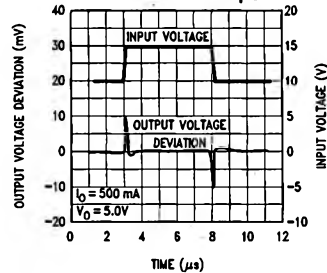

Typical Performance Characteristics for LM79MG

Peak Output Current vs Input/Output Differential Voltage

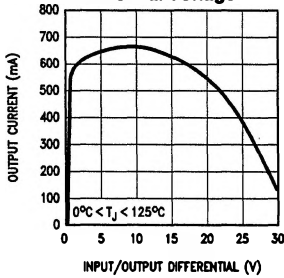

Quiescent Current vs Input Voltage

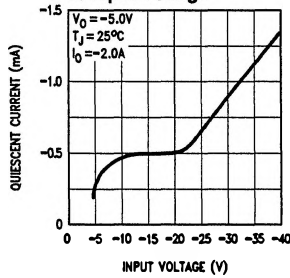

Control Current vs Temperature

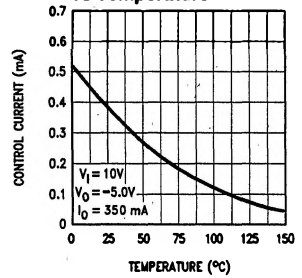

Differential Control Voltage vs Input Voltage

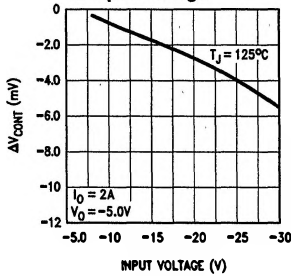

Differential Control Voltage vs Output Current

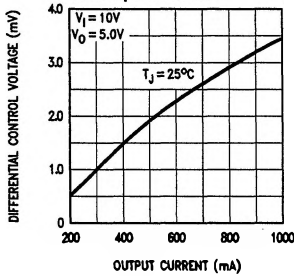

Ripple Rejection vs Output Voltage

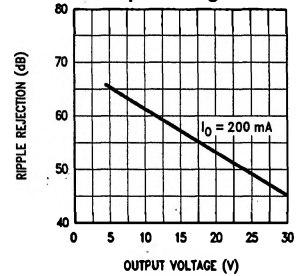

Dropout Voltage vs Junction Temperature

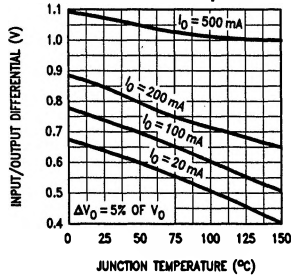

Load Transient Response

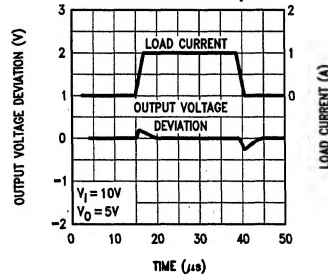

Ripple Rejection vs Frequency

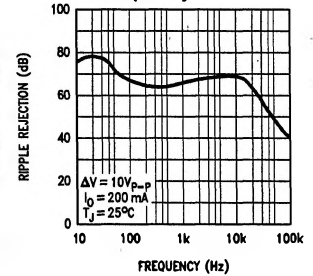

Line Transient Response

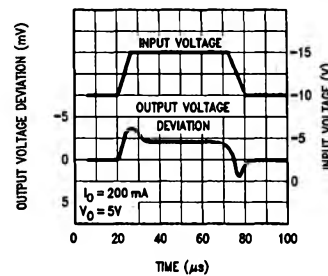

Typical Performance Characteristics for LM78MG and LM79MG

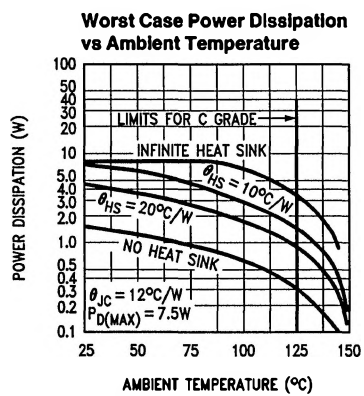

TL/H/10058-7