

LM725 Operational Amplifier

General Description

The LM725/LM725A/LM725C are operational amplifiers featuring superior performance in applications where low noise, low drift, and accurate closed-loop gain are required. With high common mode rejection and offset null capability, it is especially suited for low level instrumentation applications over a wide supply voltage range.

The LM725A has tightened electrical performance with higher input accuracy and like the LM725, is guaranteed over a -55°C to $+125^{\circ}\text{C}$ temperature range. The LM725C has slightly relaxed specifications and has its performance guaranteed over a 0°C to 70°C temperature range.

Features

- High open loop gain 3,000,000
- Low input voltage drift $0.6 \mu\text{V}/^{\circ}\text{C}$
- High common mode rejection 120 dB
- Low input noise current $0.15 \text{ pA}/\sqrt{\text{Hz}}$
- Low input offset current 2 nA
- High input voltage range $\pm 14\text{V}$
- Wide power supply range $\pm 3\text{V}$ to $\pm 22\text{V}$
- Offset null capability
- Output short circuit protection

Connection Diagrams and Ordering Information

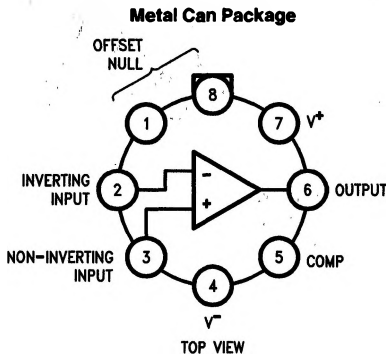

Order Number LM725H/883, LM725CH
or LM725AH/883
See NS Package Number H08C

TL/H/10474-1

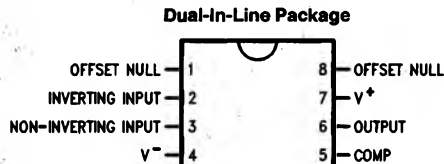

TL/H/10474-2

Order Number LM725CN
See NS Package Number N08E

Absolute Maximum Ratings

If Military/Aerospace specified devices are required, please contact the National Semiconductor Sales Office/Distributors for availability and specifications.

Supply Voltage	±22V
Internal Power Dissipation (Note 1)	500 mW
Differential Input Voltage	±5V
Input Voltage (Note 2)	±22V

Storage Temperature Range	-65°C to +150°C	
Lead Temperature (Soldering, 10 Sec.)	260°C	
Maximum Junction Temperature	150°C	
Operating Temperature Range	$T_{A(MIN)}$	$T_{A(MAX)}$
LM725	-55°C	to +125°C
LM725A	-55°C	to +125°C
LM725C	0°C	to +70°C

Electrical Characteristics (Note 3)

Parameter	Conditions	LM725A			LM725			LM725C			Units
		Min	Typ	Max	Min	Typ	Max	Min	Typ	Max	
Input Offset Voltage (Without External Trim)	$T_A = 25^\circ\text{C}$, $R_S \leq 10\text{ k}\Omega$			0.5	0.5	1.0	0.5	2.5			mV
Input Offset Current	$T_A = 25^\circ\text{C}$		2.0	5.0	2.0	20	2.0	35			nA
Input Bias Current	$T_A = 25^\circ\text{C}$		42	80	42	100	42	125			nA
Input Noise Voltage	$T_A = 25^\circ\text{C}$ $f_o = 10\text{ Hz}$ $f_o = 100\text{ Hz}$ $f_o = 1\text{ kHz}$		15		15		15				$\text{nV}/\sqrt{\text{Hz}}$ $\text{nV}/\sqrt{\text{Hz}}$ $\text{nV}/\sqrt{\text{Hz}}$
Input Noise Current	$T_A = 25^\circ\text{C}$ $f_o = 10\text{ Hz}$ $f_o = 100\text{ Hz}$ $f_o = 1\text{ kHz}$		1.0		1.0		1.0				$\text{pA}/\sqrt{\text{Hz}}$ $\text{pA}/\sqrt{\text{Hz}}$ $\text{pA}/\sqrt{\text{Hz}}$
Input Resistance	$T_A = 25^\circ\text{C}$		1.5		1.5		1.5				M Ω
Input Voltage Range	$T_A = 25^\circ\text{C}$	±13.5	±14		±13.5	±14		±13.5	±14		V
Large Signal Voltage Gain	$T_A = 25^\circ\text{C}$, $R_L \geq 2\text{ k}\Omega$, $V_{OUT} = \pm 10\text{V}$	1000	3000		1000	3000		250	3000		V/mV
Common-Mode Rejection Ratio	$T_A = 25^\circ\text{C}$, $R_S \leq 10\text{ k}\Omega$	120			110	120		94	120		dB
Power Supply Rejection Ratio	$T_A = 25^\circ\text{C}$, $R_S \leq 10\text{ k}\Omega$		2.0	5.0		2.0	10		2.0	35	$\mu\text{V}/\text{V}$
Output Voltage Swing	$T_A = 25^\circ\text{C}$, $R_L \geq 10\text{ k}\Omega$, $R_L \geq 2\text{ k}\Omega$	±12.5	±13.5		±12	±13.5		±12	±13.5		V V
Power Consumption	$T_A = 25^\circ\text{C}$		80	105		80	105		80	150	mW
Input Offset Voltage (Without External Trim)	$R_S \leq 10\text{ k}\Omega$			0.7		1.5			3.5		mV
Average Input Offset Voltage Drift (Without External Trim)	$R_S = 50\Omega$			2.0		2.0	5.0		2.0		$\mu\text{V}/^\circ\text{C}$
Average Input Offset Voltage Drift (With External Trim)	$R_S = 50\Omega$		0.6	1.0		0.6			0.6		$\mu\text{V}/^\circ\text{C}$
Input Offset Current	$T_A = T_{MAX}$ $T_A = T_{MIN}$		1.2	4.0		1.2	20		1.2	35	nA nA
Average Input Offset Current Drift			35	90		35	150		10		$\text{pA}/^\circ\text{C}$
Input Bias Current	$T_A = T_{MAX}$ $T_A = T_{MIN}$		20	70		20	100		125		nA nA

Electrical Characteristics (Note 3) (Continued)

Parameter	Conditions	LM725A			LM725			LM725C			Units
		Min	Typ	Max	Min	Typ	Max	Min	Typ	Max	
Large Signal Voltage Gain	$R_L \geq 2 \text{ k}\Omega$ $T_A = T_{MAX}$ $R_L \geq 2 \text{ k}\Omega$	1,000,000			1,000,000			125,000			V/V
	$T_A = T_{MIN}$	500,000			250,000			125,000			V/V
Common-Mode Rejection Ratio	$R_S \leq 10 \text{ k}\Omega$	110			100			115			dB
Power Supply Rejection Ratio	$R_S \leq 10 \text{ k}\Omega$	8.0			20			20			$\mu\text{V/V}$
Output Voltage Swing	$R_L \geq 2 \text{ k}\Omega$	± 12			± 10			± 10			V

Note 1: Derate at 150°C/W for operation at ambient temperatures above 75°C .

Note 2: For supply voltages less than $\pm 22\text{V}$, the absolute maximum input voltage is equal to the supply voltage.

Note 3: These specifications apply for $V_S = \pm 15\text{V}$ unless otherwise specified.

Note 4: For Military electrical specifications RETS725AX are available for LM725AH and RETS725X are available for LM725H.

Schematic Diagram

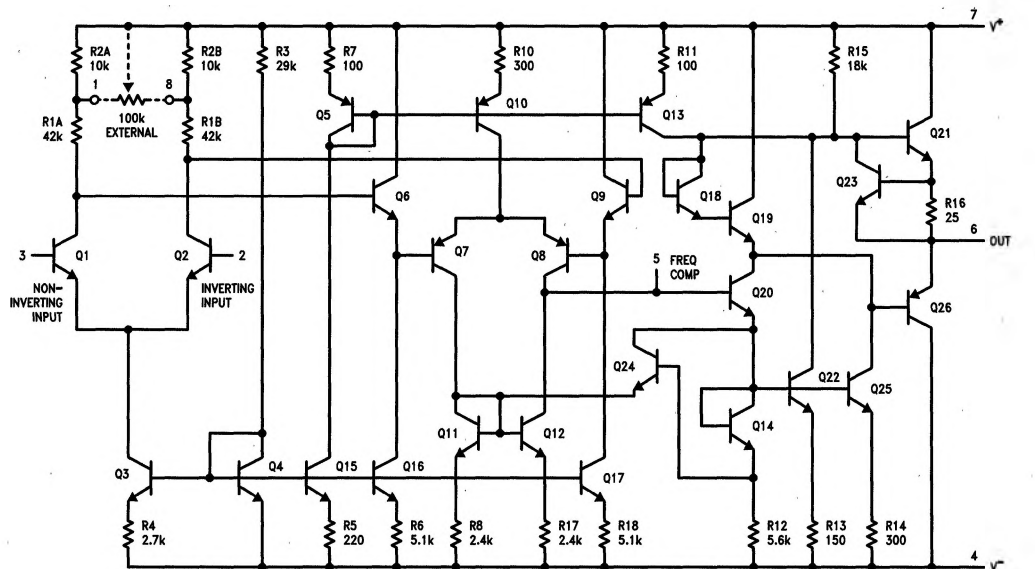

TL/H/10474-5

Typical Performance Characteristics

Voltage Gain vs Temperature for Supply Voltages

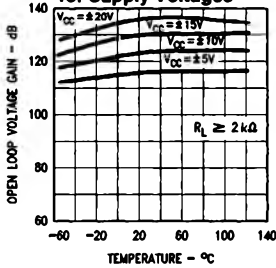

Change in Trimmed Input Offset Voltage vs Temperature

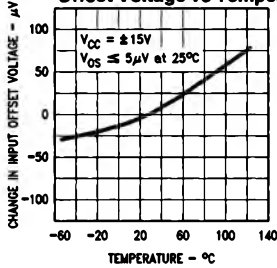

Untrimmed Input Offset Voltage vs Temperature

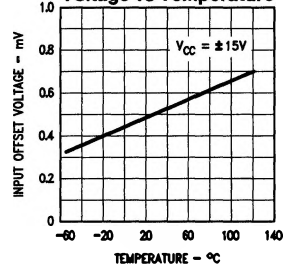

Input Offset Current vs Temperature

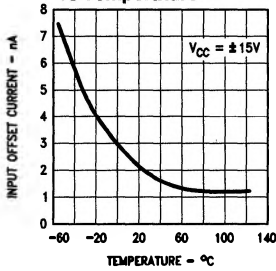

Input Bias Current vs Temperature

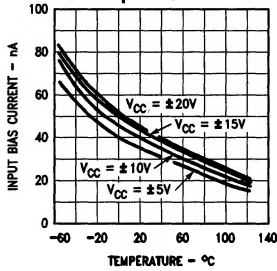

Stabilization Time of Input Offset Voltage from Power Turn-On

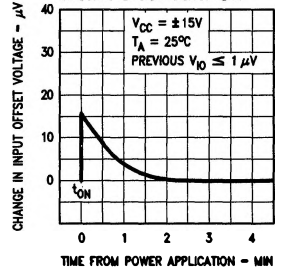

TL/H/10474-6

Typical Performance Characteristics (Continued)

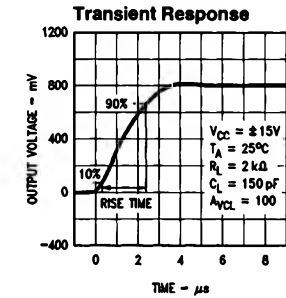
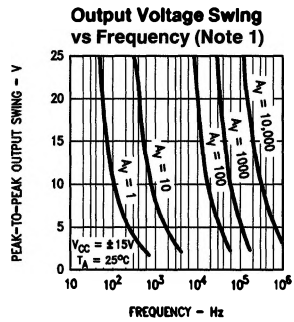
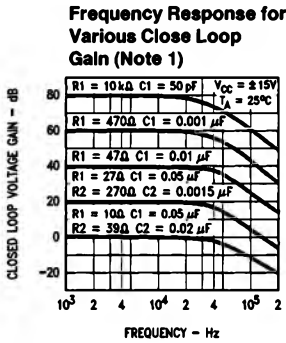
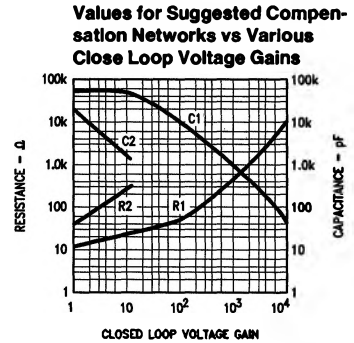
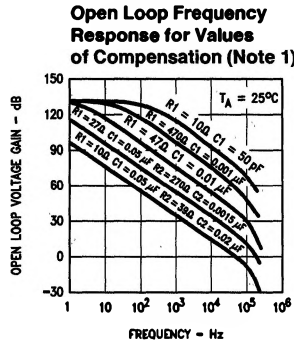
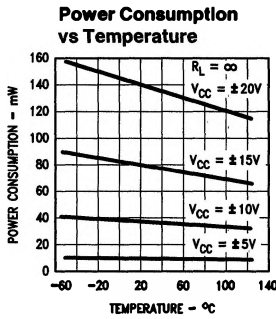
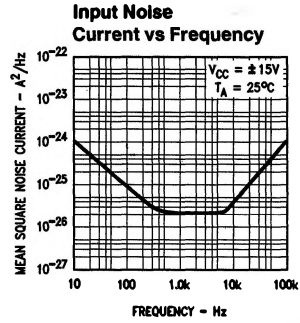
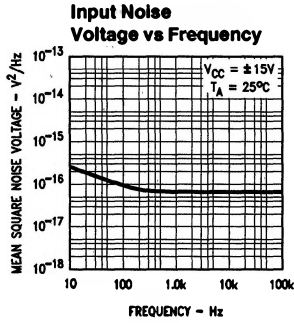
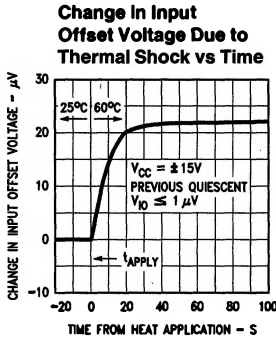

Note 1: Performance is shown using recommended compensation networks.

TL/H/10474-7

Transient Response Test Circuit

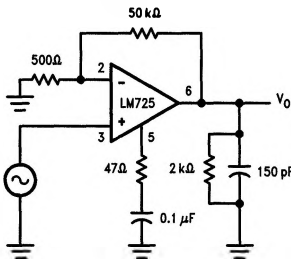

TL/H/10474-8

Auxiliary Circuits

Voltage Offset Null Circuit

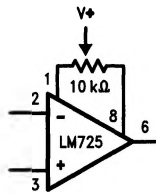

TL/H/10474-3

Frequency Compensation Circuit

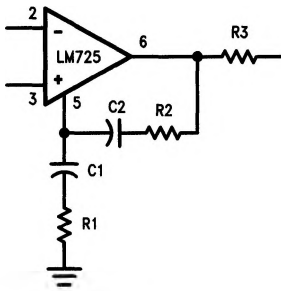

TL/H/10474-4

Compensation Component Values

A_v	R_1 (Ω)	C_1 (μF)	R_2 (Ω)	C_2 (μF)
10,000	10k	50 pF		
1,000	470	0.001		
100	47	0.01		
10	27	0.05	270	0.0015
1	10	0.05	39	0.02

Typical Applications

Photodiode Amplifier

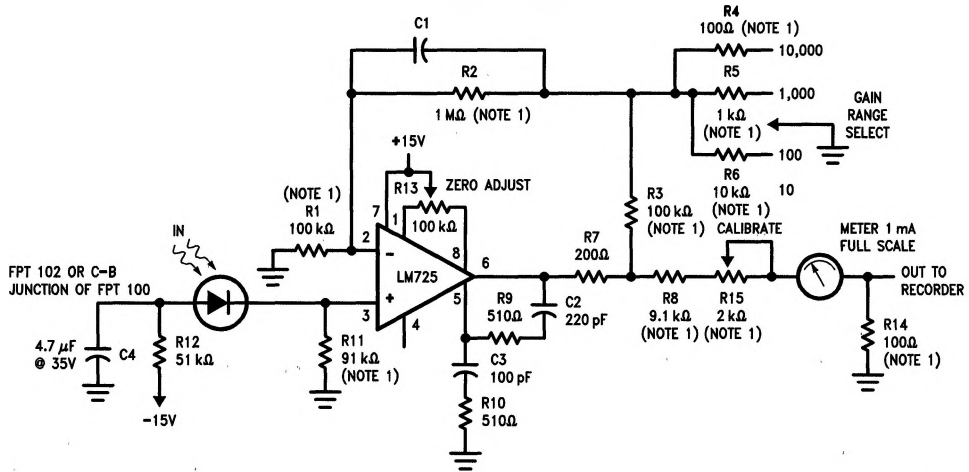

DC Gains = 10,000; 1,000; 100; and 10
 Bandwidth = Determined by value of C1

TL/H/10474-9

Thermocouple Amplifier

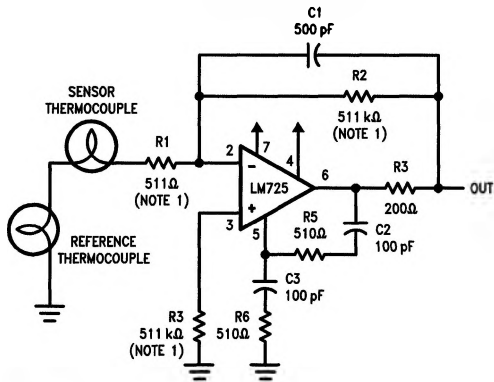

TL/H/10474-10

$$\frac{R2}{R5} = \frac{R6}{R7} \text{ for best CMR}$$

$$R1 = R4$$

$$R2 = R5$$

$$\text{Gain} = \frac{R6}{R2} + \left(\frac{2R1}{R3} \right)$$

DC Gain = 1000

Bandwidth = DC to 540 Hz

Equivalent Input Noise = 0.24 μV_{rms}

Note 1: Indicates $\pm 1\%$ metal film resistors recommended for temperature stability.

$\pm 100\text{V}$ Common Mode Range Differential Amplifier

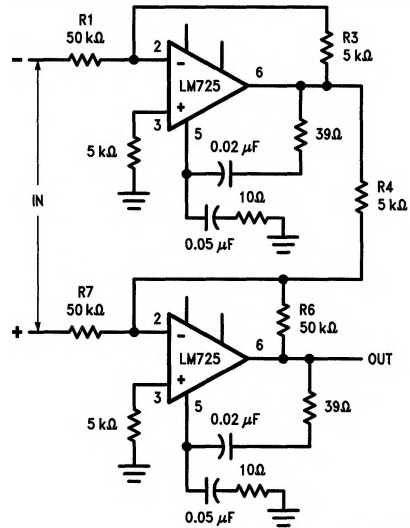

TL/H/10474-11

Typical Applications (Continued)

Instrumentation Amplifier with High Common Mode Rejection

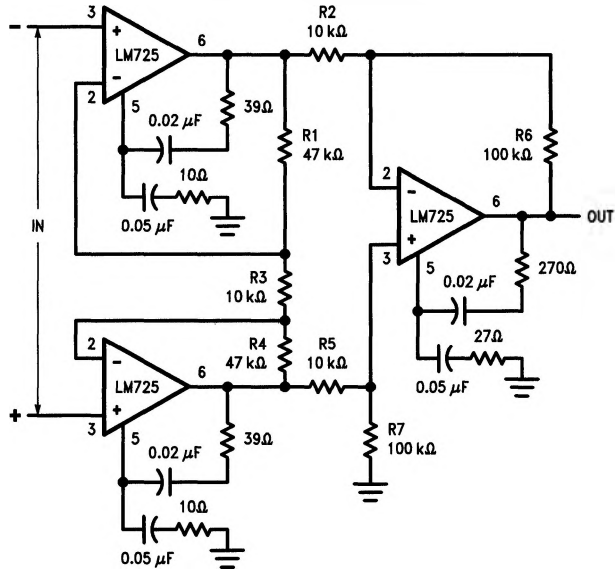

TL/H/10474-12

$\frac{R1}{R6} = \frac{R3}{R4}$ for best CMRR
 $R3 = R4$
 $R1 = R6 = 10 R3$
 $\text{Gain} = \frac{R6}{R7}$

Precision Amplifier $A_{VCL} = 1000$

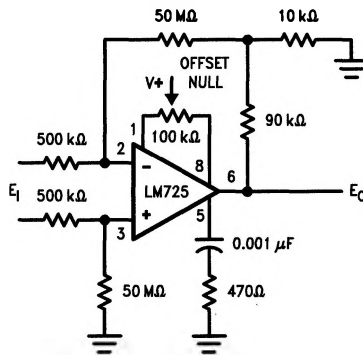

TL/H/10474-13