

LM621 Brushless Motor Commutator IC

General Description

The LM621 is a bipolar IC designed for commutation of brushless DC motors. The part is compatible with both three- and four-phase motors. It can directly drive the power switching devices used to drive the motor. The LM621 provides an adjustable dead-time circuit to eliminate "shoot-through" current spiking in the power switching circuitry. Operation is from a 5V supply, but output swings of up to 40V are accommodated. The part is packaged in an 18-pin, dual-in-line package.

Features

- Adjustable dead-time feature eliminates current spiking
- On-chip clock oscillator for dead-time feature

- Outputs drive bipolar power devices (up to 35 mA base current) or MOSFET power devices
- Compatible with three- and four-phase motors . . .
 - Bipolar drive to delta- or Y-wound motors
 - Unipolar drive to center-tapped Y-wound motors
 - Supports 30- and 60-degree shaft position sensor placements for three-phase motors
 - Supports 90-degree sensor placement for four-phase motors
- Directly interfaces to pulse-width modulator output(s) via OUTPUT INHIBIT (PWM magnitude) and DIRECTION (PWM sign) inputs
- Direct interface to Hall sensors
- Outputs are current limited
- Undervoltage lockout

Connection Diagram

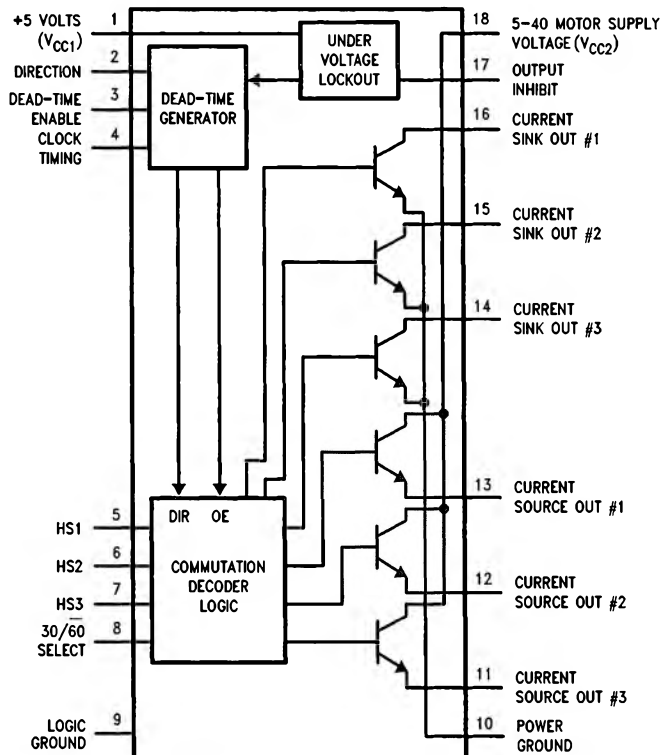

Order Number LM621N
See NS Package Number N18A

TL/H/6679-1

Absolute Maximum Ratings (See Notes)

If Military/Aerospace specified devices are required, contact the National Semiconductor Sales Office/Distributors for availability and specifications.

V _{CC1}	+7V
V _{CC2}	+45V
Logic Inputs (Note 1)	V _{CC1} + 0.5V, -0.5V
Logic Input Clamp Current	20 mA
Output Voltages	+45V, -0.5V
Output Currents	Internally current limited

Operating Ambient Temperature Range

LM621 -40°C to +85°C

Storage Temperature Range

-65°C to +150°C

Junction Temperature

150°C

ESD Susceptibility (Note 10)

2000V

Lead Temperature, N pkg.

(Soldering, 4 sec.) 260°C

Electrical Characteristics (See Notes)

Parameter	Conditions	Typ	Tested Limits	Design Limits	Units
DECODER SECTION					
High Level Input Voltage HS1, HS2, HS3: 30/60 SELECT:			2.0 2.0	2.0 2.0	V min V min
High Level Input Current HS1, HS2, HS3: 30/60 SELECT:	V _{IH} = V _{CC1} V _{IH} = V _{CC1}		100 120	200 240	μA max μA max
Low Level Input Voltage HS1, HS3 and HS2 HS1, HS3 and HS2 30/60 Select	30/60 = 5V 30/60 = 0V H _{S1} = H _{S3} = 5V		0.6 0.6 0.6	0.4 0.4 0.4	V max V max V _{max}
Low Level Input Current HS1 and HS3: HS2: 30/60 SELECT	V _{IL} = 0.35V V _{IL} = 0.4V V _{IL} = 0.0V		-400 -100 -700	-600 -200 -800	μA max μA max μA max
Input Clamp Voltage (Pins 2, 3, 5, 6, 7, 8, 17)	I _{in} = 1 mA I _{in} = -1 mA	(V _{CC1} + 0.7) (-0.6)			V V
Output Leakage Current Sinking Outputs Sourcing Outputs	Outputs Off V _{CC2} = 40V, V _{OUT} = 40V V _{OUT} = 0V	0.2 -0.2		1.0 -1.0	μA μA
Short-Circuit Current Sinking Outputs Sourcing Outputs	V _{CC2} = 10V, V _{OUT} = 10V V _{OUT} = 0V	50 -50	35 -35		mA min mA min
V _{sat} (sinking) V _{drop} (sourcing) = (V _{CC2} - V _{OUT})	I = 20 mA I = -20 mA	0.83 1.7		1.00 2.00	V max V max
Output Rise Time	(sourcing) C _L < 10 pF	50			ns
Output Fall Time	(sinking) C _L ≤ 10 pF	50			ns
Propagation Delay (Hall Input to Output)	Dead-Time Off	200			ns

Electrical Characteristics (See Notes) (Continued)

Parameter	Conditions	Typ	Tested Limits	Design Limits	Units
DEAD-TIME SECTION					
High Level Input Voltage DIRECTION: OUTPUT INHIBIT: DEAD-TIME ENABLE:	Pin 3 = 0V		2.0 2.0 2.0	2.0 2.0 2.0	V min V min V min
High Level Input Current DIRECTION: OUTPUT INHIBIT: DEAD-TIME ENABLE:	$V_{in} = 5V$ Pin 3 = 0V		100 60 200	150 100 300	μA max μA max μA max
Low Level Input Voltage DIRECTION: OUTPUT INHIBIT: DEAD-TIME ENABLE:	Pin 3 = 0V		0.6 0.6 0.3	0.4 0.4 0.2	V max V max V max
Low Level Input Current DIRECTION: OUTPUT INHIBIT: DEAD-TIME ENABLE:	$V_{in} = 0.6V$ $V_{in} = 0.6V$ $V_{in} = 0V$		-100 -60 -200	-150 -100 -300	μA max μA max μA max
Propagation Delays (Inputs to Outputs) OUTPUT INHIBIT DIRECTION	Dead-Time Off, (Pin 3 = 0V)	200 200			ns ns
Minimum Clock Period, T_{CLK} (Note 3)	$R = 11\text{ k}\Omega$ $C = 200\text{ pF}$	2.2			μs
Clock Accuracy $f = 100\text{ kHz}$	$R = 30k$ $C = 400\text{ pF}$	± 3			%
Minimum Dead-Time Minimum Dead-Time	Dead-Time Off Dead-Time On	15 2			ns T_{CLK}
COMPLETE CIRCUIT					
Total Current Drains I_{CC1} I_{CC1} I_{CC2} I_{CC2}	Outputs Off $V_{CC2} = 40V$	15 3	10 22 2 6	30 9	mA min mA max mA min mA max
Undervoltage Lockout V_{CC1}		3.6	3.0		V_{MAX}

Note 1. Unless otherwise noted ambient temperature (T_A) = 25°C.

Note 2. Unless otherwise noted: $V_{CC1} = +5.0V$, "recommended operating range $V_{CC} = 4.5V$ to $5.5V$ " $V_{CC2} = +10.0V$, ambient temperature = 25°C.

Note 3. Clock oscillator period, $T_{CLK} = RC$, where T_{CLK} is in μs , R is in $k\Omega$, and C is pF. Also see selection graph in Typical Characteristics for determining values of R and C. Note that the value of R should be no less than 11 $k\Omega$ and C no less than 200 pF.

Note 4. Tested limits are guaranteed and 100% production tested.

Note 5. Design limits are guaranteed (but not 100% production tested) at the indicated temperature and supply voltages. These limits are not used to calculate outgoing quality levels.

Note 6. Specifications in **boldface** apply over junction temperature range of -40°C to +85°C.

Note 7. Typical Thermal Resistances θ_{JA} (see Note 8):

N pkg, board mounted	110°C/W
N pkg, socketed	118°C/W

Note 8. Package thermal resistance indicates the ability of the package to dissipate heat generated on the die. Given ambient temperature and power dissipation, the thermal resistance parameter can be used to determine the approximate operating junction temperature. Operating junction temperature directly effects product performance and reliability.

Note 9. This part specifically does not have thermal shutdown protection to avoid safety problems related to an unintentional restart due to thermal time constant variations. Care should be taken to prevent excessive power dissipation on the die.

Note 10: Human body model, 100 pF, discharged through a 1500 Ω resistor.

Typical Performance Characteristics

Selection Graph for R and C

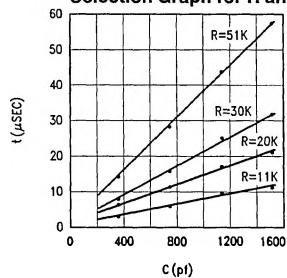

Supply Currents vs Temperature

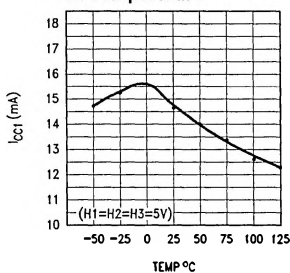

Supply Currents vs Temperature

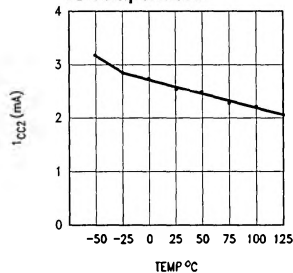

V_{sat} vs Temperature

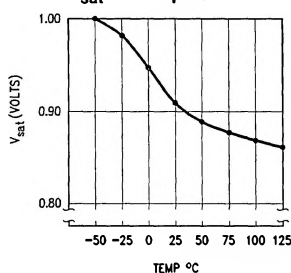

V_{drop} vs Temperature

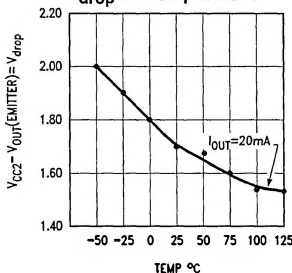

Typ. V_{sat} vs I_{out} sink
Typ. V_{drop} vs I_{out} source
(@ T_A = 25°C)

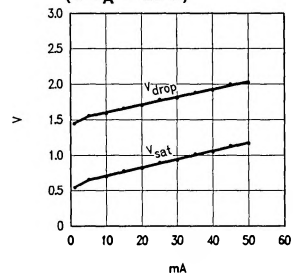

TL/H/8679-2

Description of Inputs and Outputs

Pin 1: V_{CC1} (+5V). The logic and clock power supply pin.

Pin 2: DIRECTION. This input determines the direction of rotation of the motor; ie., clockwise vs. counterclockwise. See truth table.

Pin 3: DEAD-TIME ENABLE. This input enables or disables the dead-time feature. Connecting +5V to pin 3 enables dead-time, and grounding pin 3 disables it. Pin 3 should not be allowed to float.

Pin 4: CLOCK TIMING. This pin provides for connecting an external resistor and capacitor to control the period of the clock oscillator, which determines the amount of dead-time. See *Figure 4* and text.

Pins 5 thru 7: HS1, HS2, and HS3 (Hall-sensor inputs). These inputs receive the rotor-position sensor inputs from the motor. Three-phase motors provide all three signals; four phase motors provide only two, one of which is connected to both HS2 and HS3.

Pin 8: 30/60 SELECT. This input is used to select the required decoding for three-phase motors; ie., either "30-degree" (+5V) or "60-degree" (ground). Connect pin 8 to +5V when using a four-phase motor.

Pin 9: LOGIC GROUND. Ground for the logic power supply.

Pin 10: POWER GROUND. Ground for the output buffer supply.

Pins 11 thru 13: SOURCE OUTPUTS. The three current-sourcing outputs which drive the external power devices that drive the motor.

Pins 14 thru 16: SINK OUTPUTS. The three current-sinking outputs which drive the external power devices that drive the motor.

Pin 17: OUTPUT INHIBIT. This input disables the LM621 outputs. It is typically driven by the magnitude signal from an external sign/magnitude PWM generator. Pin 17 = +5V = outputs off.

Pin 18: V_{CC2} (+5 to +40V). This is the supply for the collectors of the three current-sourcing outputs (pins 11 thru 13). When driving MOSFET power devices, pin 18 may be connected to a voltage source of up to +40V to achieve sufficient output swing for the gate. When driving bipolar power devices, pin 18 should be connected to +5V to minimize on-chip power dissipation. Undervoltage lockout automatically shuts down all outputs if the V_{CC1} supply is too low. All outputs will be off if V_{CC1} falls below the undervoltage lockout voltage.

Functional Description

The commutation decoder receives Hall-sensor inputs HS1, HS2, and HS3 and a 30/60 SELECT input. This block decodes the gray-code sequence to the required motor-drive sequence.

The dead-time generator monitors the DIRECTION input and inhibits the outputs (pins 11 thru 16) for a time sufficient to prevent current-spiking in the external power switches when the direction is reversed.

The six chip outputs drive external power switching devices which drive the motor. Three outputs source current; the remaining three sink current. The output transistors provide up to 50 mA outputs for driving devices, or up to 40V output swings for driving MOSFETs. The LM621 logic is powered from 5V.

The undervoltage lockout section monitors the V_{CC} supply and if the voltage is not sufficient to permit reliable logic operation, the outputs are shutdown.

Three-Phase Motor Commutation

There are two popular conventions for establishing the relative phasing of rotor-position signals for three-phase motors. While usually referred to as 30-degree and 60-degree sensor placements, this terminology refers to mechanical degrees of sensor placement, not electrical degrees. The electrical angular resolution is the required 60 degrees in both cases. The phasing differences can be noted by comparing the sequences of HS1 through HS3 entries in Table I,

LM621 Commutation Decoder Truth Table, which shows both the 30- and 60-degree phasings (and the 90-degree phasing for four-phase motors) and their required decoder logic truth tables, respectively. Table I shows the phasing (or codes) of the Hall-effect sensors for each 60-degree (electrical) position range of the rotor, and correlates these data to the commutator sink and source outputs required to drive the power switches. These phasings are common to several motor manufacturers. The 60-degree phasing is preferred to 30-degree phasing because the all-zeros and all-ones codes are not generated. The 60-degree phasing is more failsafe because the all-zeros and all-ones codes could be inadvertently generated by things like disconnected or shorted sensors.

Because the above terminology is not used consistently among all motor manufacturers, Table II, Alternative Sensor-phasing Names, will hopefully clarify some of the differences. Table II shows a different 60-degree phasing, and 120-, 240-, and 300-degree phasings. Comparison with Table I will show that these four phasings are essentially shifted and/or reversed-order versions of those used with the LM621.

Figure 1 shows the waveforms associated with the commutation decoder logic for a motor which has 60-degree rotor-position phasing, along with the generated motor-drive waveforms. As can be seen in the drawing, Hall-effect sensor signals HS1 through HS3 are separated by 60 electrical degrees, which is the required angular resolution for three-phase motors.

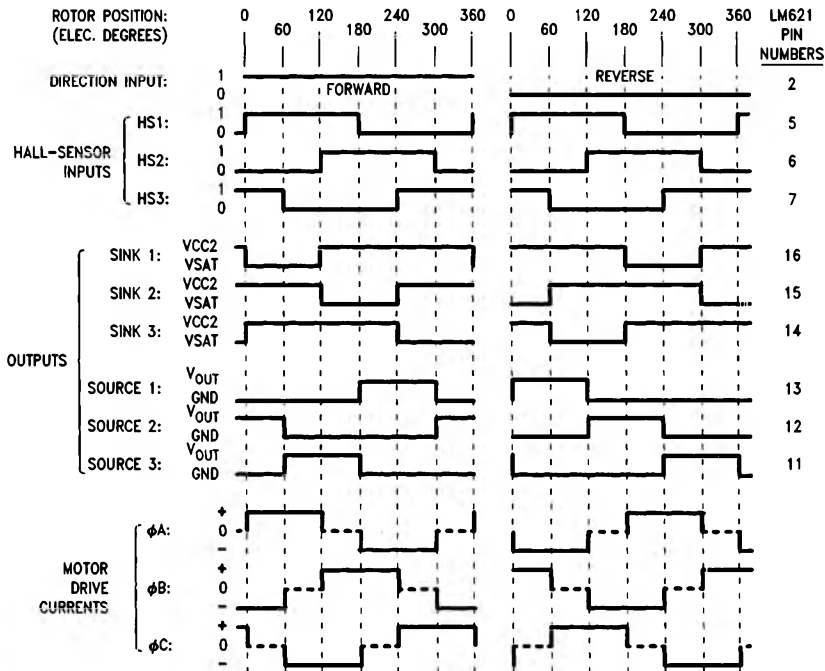

FIGURE 1. Commutation Waveforms for 60-degree Phasing

TL/H/8679-6

Three-Phase Motor Commutation (Continued)

TABLE I. LM621 Commutation Decoder Truth Table

Sensor Phasing	Position Range	Sensor Inputs			Sink Outputs			Source Outputs		
		HS1	HS2	HS3	1	2	3	1	2	3
30 deg	0–60	0	0	0	ON	off	off	off	ON	off
	60–120	0	0	1	ON	off	off	off	off	ON
	120–180	0	1	1	off	ON	off	off	off	ON
	180–240	1	1	1	off	ON	off	ON	off	off
	240–300	1	1	0	off	off	ON	ON	off	off
	300–360	1	0	0	off	off	ON	off	ON	off
60 deg	0–60	1	0	1	ON	off	off	off	ON	off
	60–120	1	0	0	ON	off	off	off	off	ON
	120–180	1	1	0	off	ON	off	off	off	ON
	180–240	0	1	0	off	ON	off	ON	off	off
	240–300	0	1	1	off	off	ON	ON	off	off
	300–360	0	0	1	off	off	ON	off	ON	off
90 deg	0–90	0	1	HS2	off	na	off	off	na	ON
	90–180	0	0	HS2	ON	na	off	off	na	off
	180–270	1	0	HS2	off	na	ON	off	na	off
	270–360	1	1	HS2	off	na	off	ON	na	off
Pin Numbers:		5	6	7	16	15	14	13	12	11

Note 1: The above outputs are generated when the Direction input, pin 2, is logic high. For reverse rotation (pin 2 logic low), the above sink and source output states become exchanged.

Note 2: For four-phase motors sink and source outputs number two (pins 15 and 12) are not used; hence the "na" (not applicable) in the appropriate columns above. Figure 6 shows how the required sink and source outputs for four-phase motors are derived.

TABLE II. Alternative Sensor-Phasing Names

Alternate Phasing	Position Range	Sensor Inputs			Corresponding LM621 Position Range and/or Comments
		HS1	HS2	HS3	
"60 deg"	0–60	0	0	0	Same as 30-degree phasing, but in reverse order; i.e., only change is relative direction.
	60–120	1	0	0	
	120–180	1	1	0	
	180–240	1	1	1	
	240–300	0	1	1	
	300–360	0	0	1	
"120 deg"	0–60	0	0	1	Same as 60-degree phasing, but with shifted order of position ranges; i.e., only change is relative phasing of sensor signals.
	60–120	1	0	1	
	120–180	1	0	0	
	180–240	1	1	0	
	240–300	0	1	0	
	300–360	0	1	1	
"240 deg"	0–60	0	1	0	Same comment as above for "120 deg" phasing.
	60–120	1	1	0	
	120–180	1	0	0	
	180–240	1	0	1	
	240–300	0	0	1	
	300–360	0	1	1	
"300 deg"	0–60	0	1	1	Same as 30-degree phasing, but with shifted order of position ranges, i.e., only change is relative phasing of sensor signals.
	60–120	1	1	1	
	120–180	1	1	0	
	180–240	1	0	0	
	240–300	0	0	0	
	300–360	0	0	1	

Four-Phase Motor Commutation

Four-phase motors use a 90-degree (quadrature) rotor-position sensor phasing. This phasing scheme is also shown in Table I. LM621 Commutation Decoder Truth Table. As shown in Table I, the 90-degree phasing has only two rotor-

position-sensor signals, HS1 and HS2. When using the LM621 to run a four-phase motor the HS2 signal is connected to both the HS2 and HS3 chip inputs.

Dead-Time Feature (Continued)

Dead-time is defined as the time the outputs are blanked off (to prevent shoot-through currents) after a direction change input. See *Figure 3*. It can be seen that the dead-time is two clock periods. Since the dead-time scheme introduces delay into the system feedback control loop, which could impact system performance or stability, it is important that the dead-time be kept to a minimum. From *Figure 3* it can be seen that the time between a direction change signal and the initiation of output blanking can vary up to one clock period due to asynchronous nature of the clock and the direction signal.

Typical Applications

THREE-PHASE EXAMPLES

Figure 4 is a typical LM621 application. This circuitry is for use with a three-phase motor having 30-degree sensor phasing, as indicated by connection of the 30/60 SELECT input, pin 8, to a logic "1" (+5V). The same connection of the DEAD-TIME ENABLE input, pin 3, enables this feature.

Typical power switches and a simple implementation of an overcurrent sensing circuit are also detailed in *Figure 4*. This application example assumes a device turn-off time of about 4.8 μ s maximum, as evidenced by the choice of R and C. See Typical Performance Characteristics. The choice of RC should be made such that two periods are at least equal to the maximum device turn-off time.

The choice of the value for R_{LIMIT} (the resistors which couple the LM621 outputs to the power switches) depends on the input current requirements of the power switching devices. These resistors should be chosen to provide only the amount of current needed by the device inputs, up to 50 mA (typical). The resistors minimize the dissipation incurred by the LM621. Although *Figure 4* shows the 5–40V supply (pin 18) connected to the motor supply voltage, this was done only to emphasize the ability of the part to provide up to 40V output swings. For the bipolar power switches shown, connecting pin 18 to a 5V supply would reduce on-chip power dissipation. Driving FET power switches, however, may require connecting pin 18 to a higher voltage. *Figure 5* is the three-phase application built with MOSFET power-switching components. Note that since the output V_{drop} (sourcing) is at least 1.5V, V_{CC2} can be chosen to avoid overdriving the MOSFET gates.

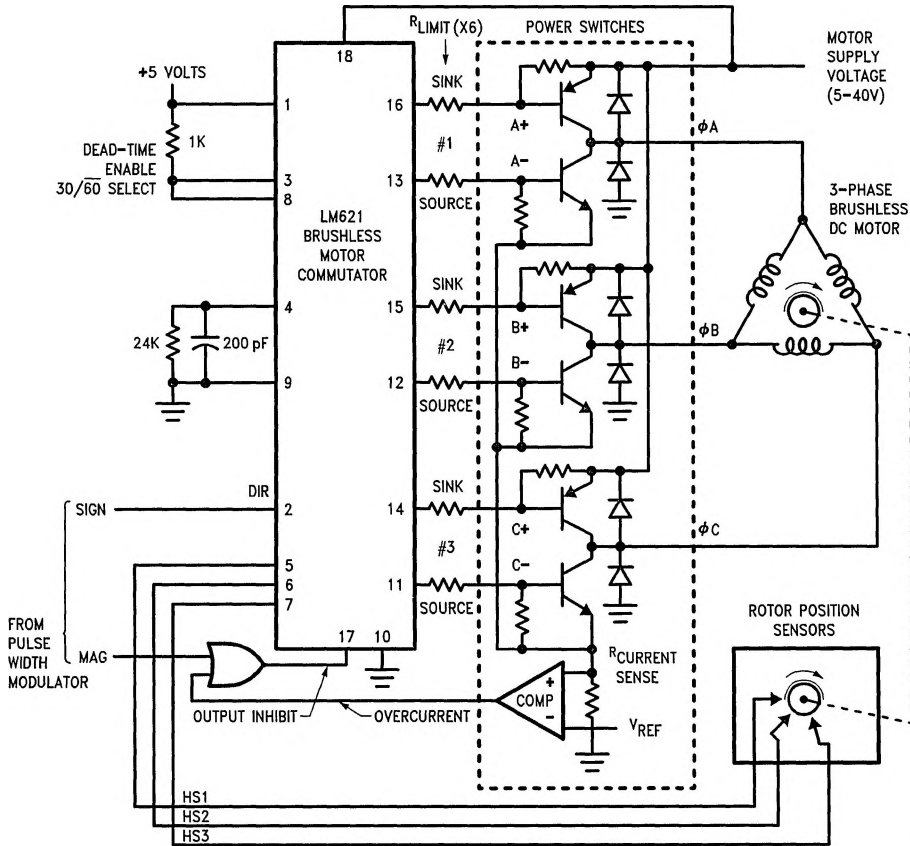

FIGURE 4. Commutation of Three-Phase Motor (Bipolar Switches)

TL/H/8679-9

Typical Applications (Continued)

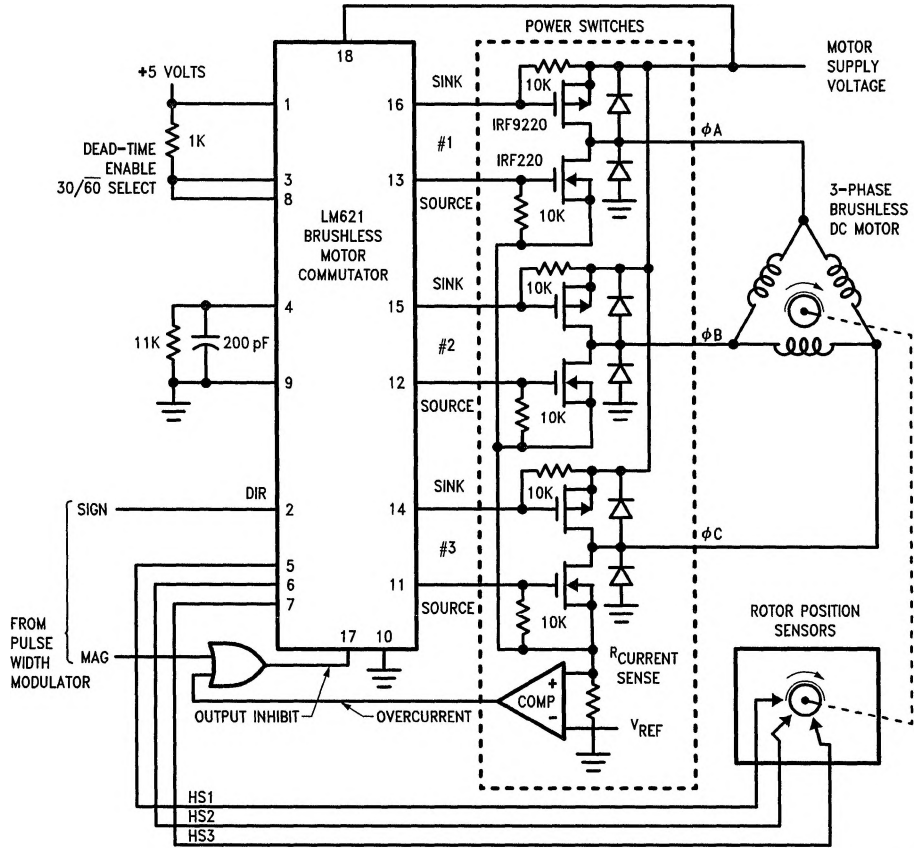

FIGURE 5. Commutation of Three-Phase Motor (MOSFET Switches)

TL/H/8679-10

Typical Applications (Continued)

FOUR-PHASE EXAMPLE

Figure 6 is typical of the circuitry used to commutate a four-phase motor using the LM621. This application is seen to differ from the three-phase application example in that the LM621 outputs are utilized differently. Four-phase motors require four-phase power switches, which in turn require the commutator to provide four current-sinking outputs and four current sourcing outputs. The 18-pin package of the LM621 facilitates only three sinking and three sourcing outputs. The schematic shows the 30/60 SELECT input in the 30-degree select state (pin 8 high) and rotor-position sensor inputs HS2 and HS3 connected together. This connection truncates the number of possible rotor-position input states to four, which is consistent with the 90-degree quadrature rotor-position signals provided by four-phase motors. With the LM621 outputs connected as shown, this approach provides the needed power-switch drive signals for a four-phase motor. Note that only four of the six LM621 outputs (SINK #1 and #3, and SOURCE #1 and #3) are used

directly, and that these are also inverted to form the remaining four. SINK #2 and SOURCE #2 outputs are not used.

HALF-WAVE DRIVE EXAMPLE

The previous applications examples involved delta-configured motor windings and full-wave operation of the motor. The application shown in Figure 7 differs in that it features half-wave operation of a motor with the windings in a Y-configuration. This approach is suitable for automotive and other applications where only low-voltage power supplies are conveniently available. The advantage of this power-switching scheme is that there is only one switch-voltage drop in series with the motor winding, thereby conserving more of the available voltage for application to the motor winding. Half-wave operation provides only unidirectional current to the windings; in contrast to the bidirectional currents applied by the previous full-wave examples.

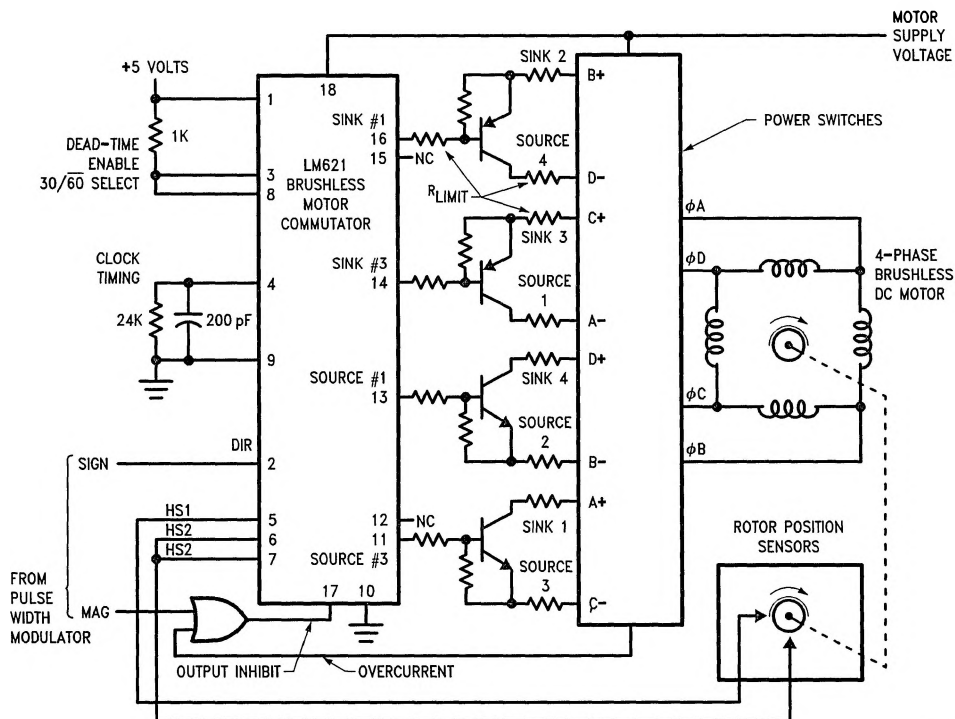

FIGURE 6. Commutation of Four-Phase Motor

TL/H/8679-11

Typical Applications (Continued)

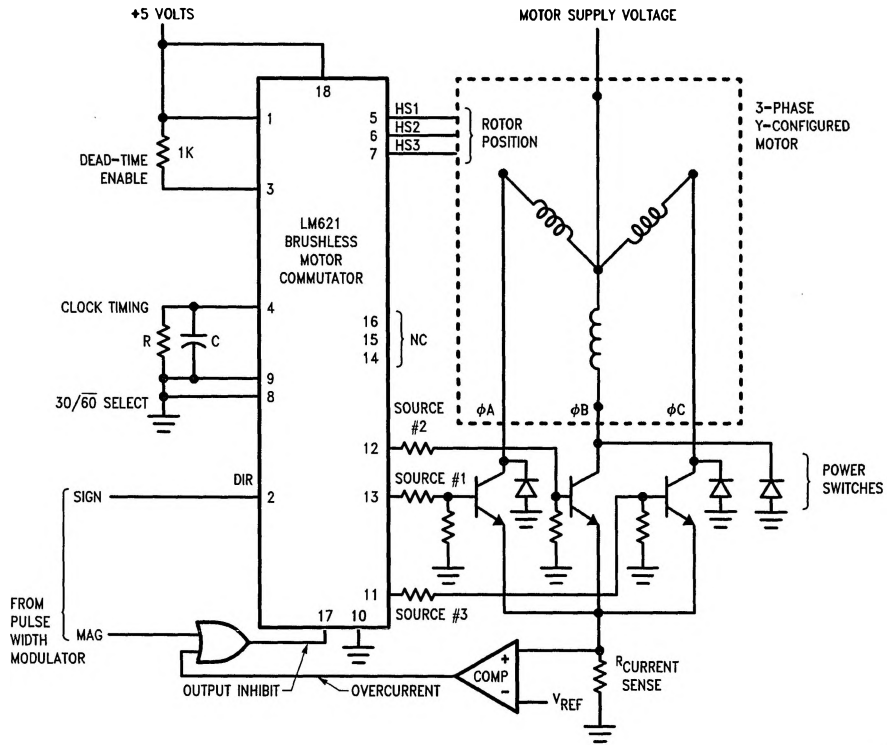

FIGURE 7. Half-Wave Drive of Y-Configured Motor

TL/H/8679-12