

## LM6162 High Speed Operational Amplifier

Check for Samples: [LM6162](#)

### FEATURES

- High slew rate: 300 V/ $\mu$ s
- High gain-bandwidth product: 100 MHz
- Low supply current: 5 mA
- Fast settling time: 120 ns to 0.1%
- Low differential gain: <0.1%
- Low differential phase: <0.1°
- Wide supply range: 4.75V to 32V
- Stable with unlimited capacitive load
- Well behaved; easy to apply

### APPLICATIONS

- Video amplifier
- Wide-bandwidth signal conditioning for image processing (FAX, scanners, laser printers)
- Hard disk drive preamplifier
- Error amplifier for high-speed switching regulator

### DESCRIPTION

The LM6162 family of high-speed amplifiers exhibits an excellent speed-power product, delivering 300 V/ $\mu$ s and 100 MHz gain-bandwidth product (stable for gains as low as +2 or -1) with only 5 mA of supply current. Further power savings and application convenience are possible by taking advantage of the wide dynamic range in operating supply voltage which extends all the way down to +5V.

These amplifiers are built with National's VIP™ (Vertically Integrated PNP) process which provides fast transistors that are true complements to the already fast NPN devices. This advanced junction-isolated process delivers high speed performance without the need for complex and expensive dielectric isolation.

### Connection Diagram

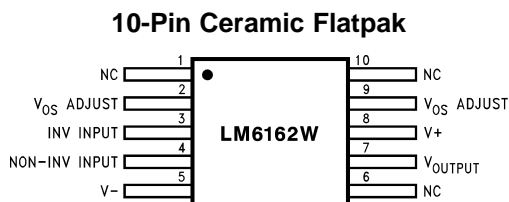

**Figure 1. Top View**  
See NS Package Number W10A

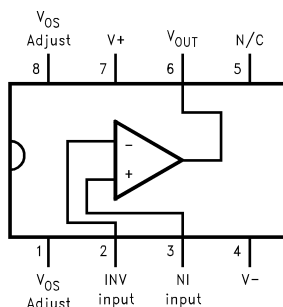

**Figure 2. See NS Package Number N08E or J08A**



Please be aware that an important notice concerning availability, standard warranty, and use in critical applications of Texas Instruments semiconductor products and disclaimers thereto appears at the end of this data sheet.

VIP is a trademark of Texas Instruments.

All other trademarks are the property of their respective owners.



These devices have limited built-in ESD protection. The leads should be shorted together or the device placed in conductive foam during storage or handling to prevent electrostatic damage to the MOS gates.

### Absolute Maximum Ratings <sup>(1)</sup>

Supply Voltage ( $V^+ - V^-$ )	36V
Differential Input Voltage <sup>(2)</sup>	$\pm 8V$
Common-Mode Input Voltage <sup>(3)</sup>	( $V^+ - 0.7V$ ) to ( $V^- + 0.7V$ )
Output Short Circuit to GND <sup>(4)</sup>	Continuous
Soldering Information	
Dual-In-Line Package (N)	
Soldering (10 seconds)	260°C
Small Outline Package (M)	
Vapor Phase (60 seconds)	215°C
Infrared (15 seconds)	220°C
See AN-450 "Surface Mounting Methods and Their Effect on Product Reliability" for other methods of soldering surface mount devices.	
Storage Temperature Range	$-65^\circ\text{C} \leq T_J \leq +150^\circ\text{C}$
Max Junction Temperature	150°C
ESD Tolerance <sup>(5)</sup>	$\pm 1100V$

- (1) Absolute maximum ratings indicate limits beyond which damage to the component may occur. Electrical specifications do not apply when operating the device beyond its rated operating conditions.
- (2) The ESD protection circuitry between the inputs will begin to conduct when the differential input voltage reaches 8V.
- (3) a) In addition, the voltage between the  $V^+$  pin and either input pin must not exceed 36V. b) When the voltage applied to an input pin is driven more than 3V below the negative supply pin voltage, a substrate diode begins to conduct. Current through this pin must then be kept less than 20 mA to limit damage from self-heating.
- (4) Although the output current is internally limited, continuous short-circuit operation at elevated ambient temperature can result in exceeding the maximum allowed junction temperature of 150°C.
- (5) This value is the average voltage that the weakest pin combinations can withstand and still conform to the datasheet limits. The test circuit used consists of the human body model, 100 pF in series with 1500Ω.

### Operating Ratings

Temperature Range <sup>(1)</sup>	
LM6162	$-55^\circ\text{C} \leq T_J \leq +125^\circ\text{C}$
Supply Voltage Range	4.75V to 32V

- (1) The typical thermal resistance, junction-to-ambient, of the molded plastic DIP (N package) is 105°C/W. For the molded plastic SO (M package), use 155°C/W. All numbers apply for packages soldered directly into a printed circuit board.

## DC Electrical Characteristics

These limits apply for supply voltage =  $\pm 15\text{V}$ ,  $V_{\text{CM}} = 0\text{V}$ , and  $R_{\text{L}} \geq 100\text{ k}\Omega$ , unless otherwise specified. Limits in standard typeface are for  $T_{\text{A}} = T_{\text{J}} = 25^{\circ}\text{C}$ ; limits in **boldface type** apply over the **Operating Temperature Range**.

Symbol	Parameter	Conditions	Typical (1)	LM6162	
				Limit (2)	Units
$V_{\text{OS}}$	Input Offset Voltage		$\pm 3$	$\pm 5$	mV
				<b><math>\pm 8</math></b>	max
$\frac{\Delta V_{\text{OS}}}{\Delta \text{Temp}}$ (1)	Input Offset Voltage		7		$\mu\text{V}/^{\circ}\text{C}$
	Average Drift				
$I_{\text{bias}}$	Input Bias Current		2.2	3	$\mu\text{A}$
				<b>6</b>	max
$I_{\text{OS}}$	Input Offset Current		$\pm 150$	$\pm 350$	nA
				<b><math>\pm 800</math></b>	max
$\frac{\Delta I_{\text{OS}}}{\Delta \text{Temp}}$ (2)	Input Offset Current		0.3		$\text{nA}/^{\circ}\text{C}$
	Average Drift				
$R_{\text{IN}}$	Input Resistance	Differential	180		$\text{k}\Omega$
$C_{\text{IN}}$	Input Capacitance		2.0		pF
$A_{\text{VOL}}$	Large Signal	$V_{\text{OUT}} = \pm 10\text{V}$ , $R_{\text{L}} = 2\text{ k}\Omega$	1400	1000	V/V
	Voltage Gain	(3)		<b>500</b>	min
		$R_{\text{L}} = 10\text{ k}\Omega$	6500		V/V
$V_{\text{CM}}$	Input Common-Mode	Supply = $\pm 15\text{V}$	+14.0	+13.9	V
	Voltage Range			<b>+13.8</b>	min
			-13.2	-12.9	V
				<b>-12.7</b>	max
		Supply = +5V	4.0	3.9	V
		(4)		<b>3.8</b>	min
			1.6	1.8	V
				<b>2.0</b>	max
CMRR	Common-Mode	$-10\text{V} \leq V_{\text{CM}} \leq +10\text{V}$	100	83	dB
	Rejection Ratio			<b>79</b>	min
PSRR	Power Supply	$\pm 10\text{V} \leq V_{\text{S}} \leq \pm 16\text{V}$	93	83	dB
	Rejection Ratio			<b>79</b>	min
$V_{\text{O}}$	Output Voltage	Supply = $\pm 15\text{V}$ , $R_{\text{L}} = 2\text{ k}\Omega$	+14.2	+13.5	V
	Swing			<b>+13.3</b>	min
			-13.4	-13.0	V
				<b>-12.7</b>	max
$V_{\text{O}}$	Output Voltage Swing	Supply = +5V and	4.2	3.5	V
		$R_{\text{L}} = 2\text{ k}\Omega$ (4)		<b>3.3</b>	min
			1.3	1.7	V
				<b>2.0</b>	max
$I_{\text{osc}}$	Output Short	Sourcing	65	30	mA
	Circuit Current			<b>20</b>	min
		Sinking	65	30	mA
				<b>20</b>	min

(1) Typical values are for  $T_{\text{J}} = 25^{\circ}\text{C}$ , and represent the most likely parametric norm.

(2) Limits are guaranteed, by testing or correlation.

(3) Voltage Gain is the total output swing (20V) divided by the magnitude of the input signal required to produce that swing.

(4) For single-supply operation, the following conditions apply:  $V^{+} = 5\text{V}$ ,  $V^{-} = 0\text{V}$ ,  $V_{\text{CM}} = 2.5\text{V}$ ,  $V_{\text{OUT}} = 2.5\text{V}$ . Pin 1 and Pin 8 ( $V_{\text{OS}}$  Adjust pins) are each connected to pin 4 ( $V^{-}$ ) to realize maximum output swing. This connection will increase the offset voltage.

**DC Electrical Characteristics (continued)**

These limits apply for supply voltage =  $\pm 15\text{V}$ ,  $V_{\text{CM}} = 0\text{V}$ , and  $R_{\text{L}} \geq 100\text{ k}\Omega$ , unless otherwise specified. Limits in standard typeface are for  $T_{\text{A}} = T_{\text{J}} = 25^{\circ}\text{C}$ ; limits in **boldface type** apply over the **Operating Temperature Range**.

Symbol	Parameter	Conditions	Typical (1)	LM6162	
				Limit (2)	Units
$I_{\text{S}}$	Supply Current		5.0	6.5	mA
				<b>6.8</b>	max

## AC Electrical Characteristics

These limits apply for supply voltage =  $\pm 15V$ ,  $V_{CM} = 0V$ ,  $R_L \geq 100\text{ k}\Omega$ , and  $C_L \leq 5\text{ pF}$ , unless otherwise specified. Limits in standard typeface are for  $T_A = T_J = 25^\circ\text{C}$ ; limits in **boldface type** apply over the **Operating Temperature Range**.

Symbol	Parameter	Conditions	Typical (1)	LM6162			
				Limit (2)	Units		
GBW	Gain-Bandwidth Product	$f = 20\text{ MHz}$	100	80	MHz		
				<b>55</b>	min		
					MHz		
SR	Slew Rate	$A_V = +2$ (3)	300	200	V/ $\mu\text{s}$		
				<b>180</b>	min		
					V/ $\mu\text{s}$		
PBW	Power Bandwidth	$V_{OUT} = 20\text{ V}_{PP}$	4.5		MHz		
$t_s$	Settling Time	10V step, to 0.1%	100		ns		
$\Phi_m$	Phase Margin	$A_V = +2$	45		deg		
				Differential Gain	NTSC, $A_V = +2$	<0.1	%
$e_n$	Input Noise Voltage	$f = 10\text{ kHz}$	10		nV/ $\sqrt{\text{Hz}}$		
$i_n$	Input Noise Current	$f = 10\text{ kHz}$	1.2		pA/ $\sqrt{\text{Hz}}$		

- (1) Typical values are for  $T_J = 25^\circ\text{C}$ , and represent the most likely parametric norm.
- (2) Limits are guaranteed, by testing or correlation.
- (3)  $V_{IN} = 10V$  step. For  $\pm 5V$  supplies,  $V_{IN} = 1V$  step.

### Typical Performance Characteristics

$R_L = 10\text{ k}\Omega$ ,  $T_A = 25^\circ\text{C}$  unless otherwise noted

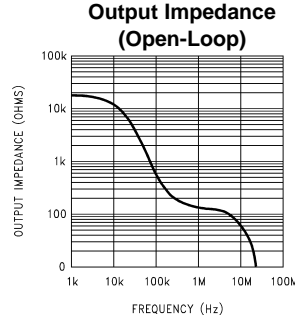
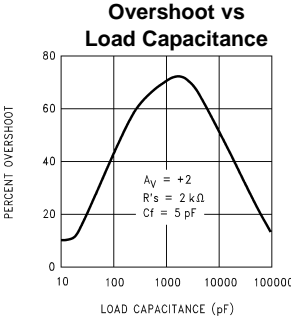
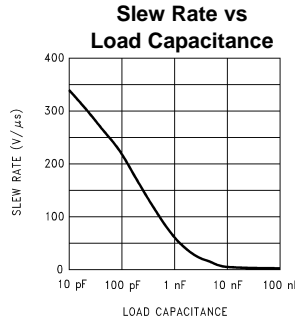
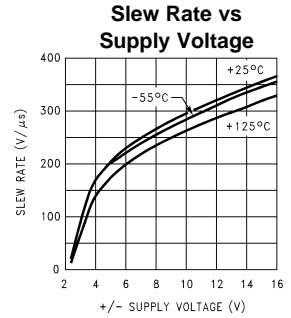
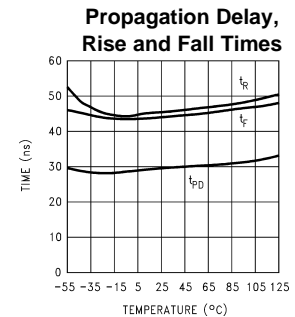
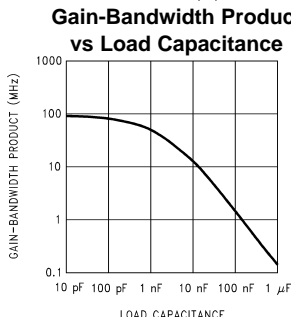
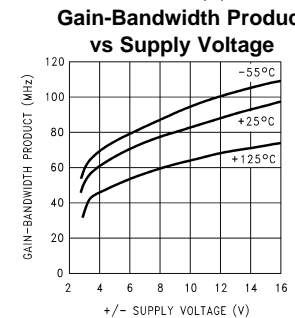
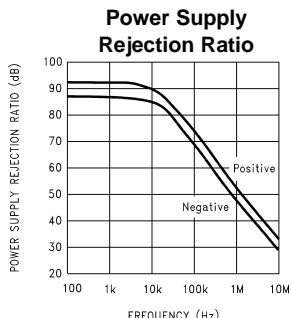
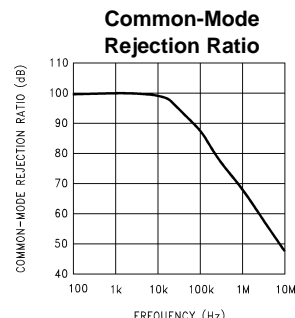
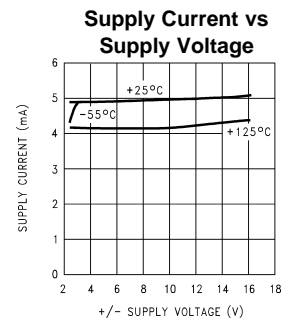

Typical Performance Characteristics (continued)

$R_L = 10\text{ k}\Omega$ ,  $T_A = 25^\circ\text{C}$  unless otherwise noted

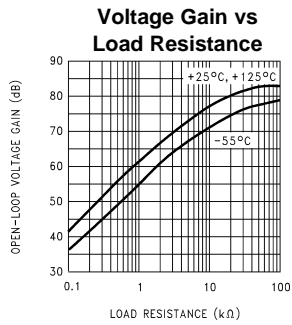

Figure .

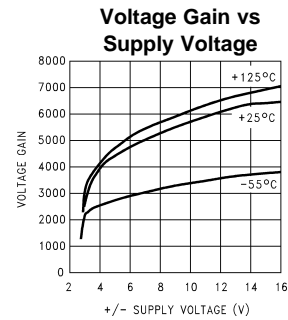
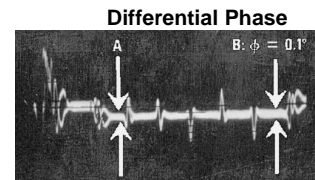
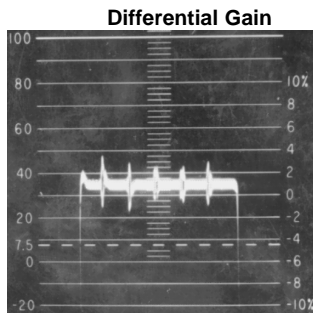
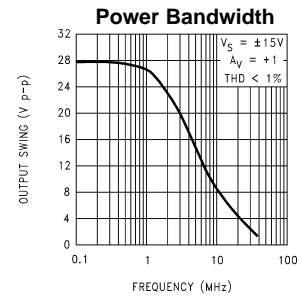
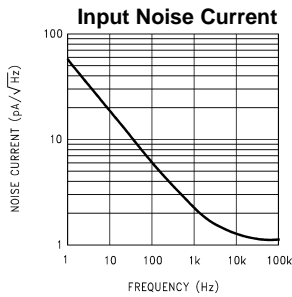
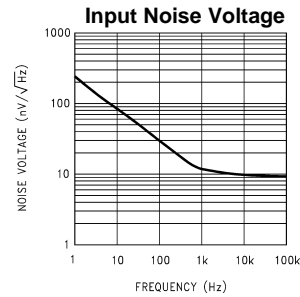
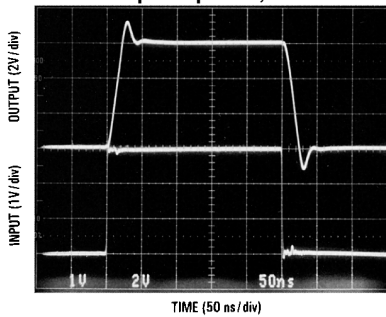

Figure 3. Differential Gain (Note)



Differential gain and differential phase measured for four series LM6162 op amps configured with gain of +2 each, in series with a 1:16 attenuator and an LM6321 buffer. Error added by LM6321 is negligible. Test performed using Tektronix Type 520 NTSC test system.

Step Response;  $A_v = +2$



### Typical Performance Characteristics (continued)

$R_L = 10\text{ k}\Omega$ ,  $T_A = 25^\circ\text{C}$  unless otherwise noted

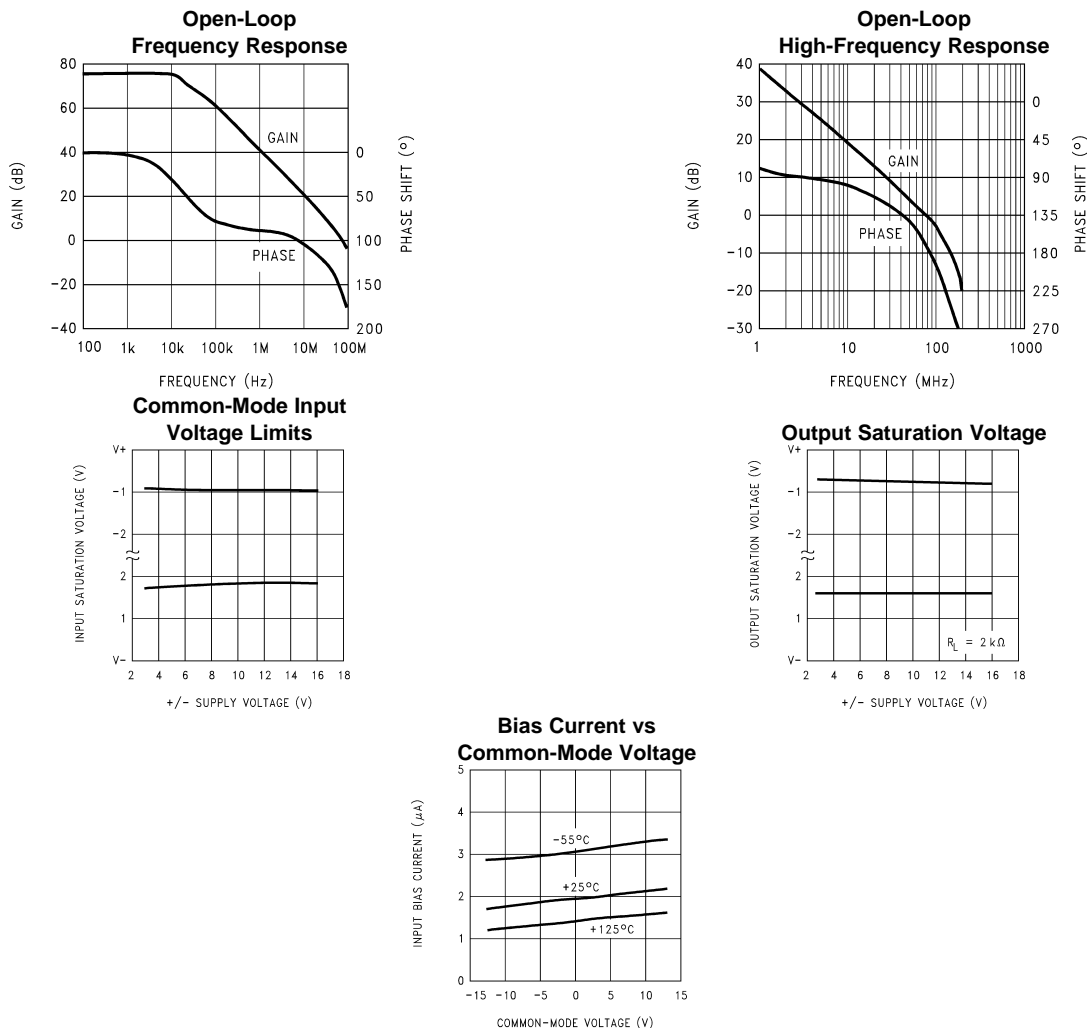

### Simplified Schematic

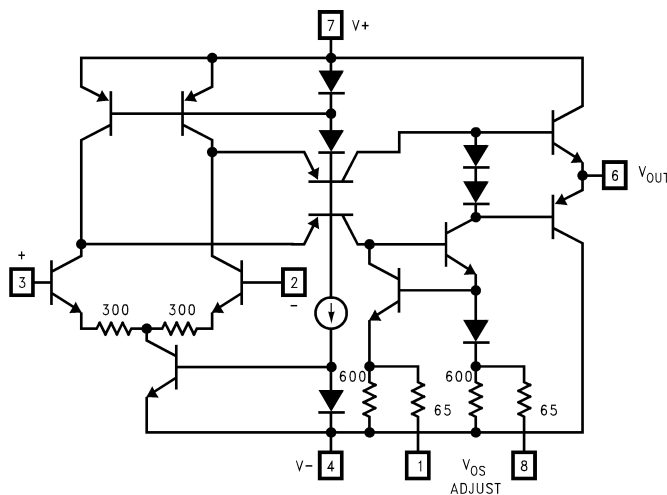

Figure 4. Simplified Schematic

## Application Tips

The LM6162 has been decompensated for a wider gain-bandwidth product than the LM6361. However, the LM6162 still offers stability at gains of 2 (and  $-1$ ) or greater over the specified ranges of temperature, power supply voltage, and load. Since this decompensation involved reducing the emitter-degeneration resistors in the op amp's input stage, the DC precision has been increased in the form of lower offset voltage and higher open-loop gain.

Other op amps in this family include the LM6361, LM6364, and LM6365. If unity-gain stability is required, the LM6361 should be used. The LM6364 has been decompensated for operation at gains of 5 or more, with corresponding greater gain-bandwidth product (125 MHz, typical) and DC precision. The fully-uncompensated LM6365 offers gain-bandwidth product of 725 MHz, typical, and is stable for gains of 25 or more. All parts in this family, regardless of compensation, have the same high slew rate of 300 V/ $\mu$ s (typ).

The LM6162 is unusually tolerant of capacitive loads. Most op amps tend to oscillate when their load capacitance is greater than about 200 pF (in low-gain circuits). However, load capacitance on the LM6162 effectively increases its compensation capacitance, thus slowing the op amp's response and reducing its bandwidth. The compensation is not ideal, though, and ringing may occur in low-gain circuits with large capacitive loads.

Power supply bypassing is not as critical for LM6162 as it is for other op amps in its speed class. However, bypassing will improve the stability and transient response of the LM6162, and is recommended for every design. 0.01  $\mu$ F to 0.1  $\mu$ F ceramic capacitors should be used (from each supply "rail" to ground); if the device is far away from its power supply source, an additional 2.2  $\mu$ F to 10  $\mu$ F of tantalum may be required for extra noise reduction.

Keep all leads short to reduce stray capacitance and lead inductance, and make sure ground paths are low-impedance, especially where heavier currents will be flowing. Stray capacitance in the circuit layout can cause signal coupling from one pin, input or lead to another, and can cause circuit gain to unintentionally vary with frequency.

Breadboarded circuits will work best if they are built using generic PC boards with a good ground plane. If the op amps are used with sockets, as opposed to being soldered into the circuit, the additional input capacitance may degrade circuit frequency response. At low gains ( $+2$  or  $-1$ ), a feedback capacitor  $C_f$  from output to inverting input will compensate for the phase lag caused by capacitance at the inverting input. Typically, values from 2 pF to 5 pF work well; however, best results can be obtained by observing the amplifier pulse response and optimizing  $C_f$  for the particular layout.

## Typical Applications

**Figure 5. Offset Voltage Adjustment**

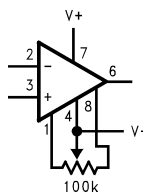

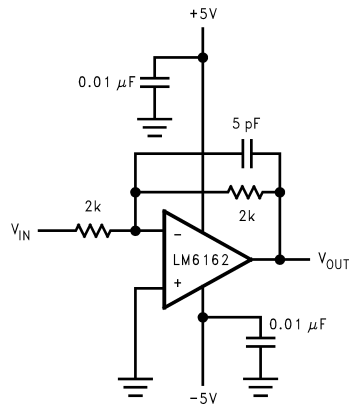
**Figure 6. Inverting Amplifier, 30 MHz Bandwidth**

Operation on  $\pm 15\text{V}$  supplies results in wider bandwidth, 50 MHz (typ).

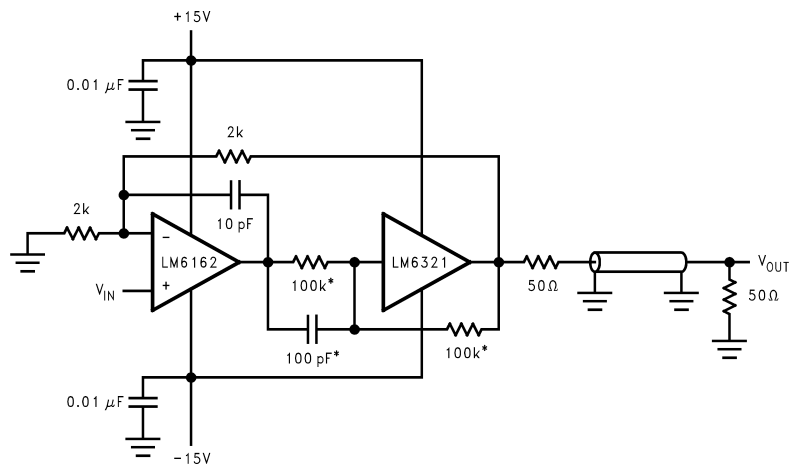
**Figure 7. Video Cable Driver**

\* Network required when operating on supply voltage over  $\pm 5\text{V}$ , for overvoltage protection of LM6321. If  $\pm 5\text{V}$  supplies are used, omit network and connect output of LM6162 directly to input of LM6321.

## IMPORTANT NOTICE

Texas Instruments Incorporated and its subsidiaries (TI) reserve the right to make corrections, enhancements, improvements and other changes to its semiconductor products and services per JESD46, latest issue, and to discontinue any product or service per JESD48, latest issue. Buyers should obtain the latest relevant information before placing orders and should verify that such information is current and complete. All semiconductor products (also referred to herein as "components") are sold subject to TI's terms and conditions of sale supplied at the time of order acknowledgment.

TI warrants performance of its components to the specifications applicable at the time of sale, in accordance with the warranty in TI's terms and conditions of sale of semiconductor products. Testing and other quality control techniques are used to the extent TI deems necessary to support this warranty. Except where mandated by applicable law, testing of all parameters of each component is not necessarily performed.

TI assumes no liability for applications assistance or the design of Buyers' products. Buyers are responsible for their products and applications using TI components. To minimize the risks associated with Buyers' products and applications, Buyers should provide adequate design and operating safeguards.

TI does not warrant or represent that any license, either express or implied, is granted under any patent right, copyright, mask work right, or other intellectual property right relating to any combination, machine, or process in which TI components or services are used. Information published by TI regarding third-party products or services does not constitute a license to use such products or services or a warranty or endorsement thereof. Use of such information may require a license from a third party under the patents or other intellectual property of the third party, or a license from TI under the patents or other intellectual property of TI.

Reproduction of significant portions of TI information in TI data books or data sheets is permissible only if reproduction is without alteration and is accompanied by all associated warranties, conditions, limitations, and notices. TI is not responsible or liable for such altered documentation. Information of third parties may be subject to additional restrictions.

Resale of TI components or services with statements different from or beyond the parameters stated by TI for that component or service voids all express and any implied warranties for the associated TI component or service and is an unfair and deceptive business practice. TI is not responsible or liable for any such statements.

Buyer acknowledges and agrees that it is solely responsible for compliance with all legal, regulatory and safety-related requirements concerning its products, and any use of TI components in its applications, notwithstanding any applications-related information or support that may be provided by TI. Buyer represents and agrees that it has all the necessary expertise to create and implement safeguards which anticipate dangerous consequences of failures, monitor failures and their consequences, lessen the likelihood of failures that might cause harm and take appropriate remedial actions. Buyer will fully indemnify TI and its representatives against any damages arising out of the use of any TI components in safety-critical applications.

In some cases, TI components may be promoted specifically to facilitate safety-related applications. With such components, TI's goal is to help enable customers to design and create their own end-product solutions that meet applicable functional safety standards and requirements. Nonetheless, such components are subject to these terms.

No TI components are authorized for use in FDA Class III (or similar life-critical medical equipment) unless authorized officers of the parties have executed a special agreement specifically governing such use.

Only those TI components which TI has specifically designated as military grade or "enhanced plastic" are designed and intended for use in military/aerospace applications or environments. Buyer acknowledges and agrees that any military or aerospace use of TI components which have **not** been so designated is solely at the Buyer's risk, and that Buyer is solely responsible for compliance with all legal and regulatory requirements in connection with such use.

TI has specifically designated certain components as meeting ISO/TS16949 requirements, mainly for automotive use. In any case of use of non-designated products, TI will not be responsible for any failure to meet ISO/TS16949.

### Products

Audio	<a href="http://www.ti.com/audio">www.ti.com/audio</a>
Amplifiers	<a href="http://amplifier.ti.com">amplifier.ti.com</a>
Data Converters	<a href="http://dataconverter.ti.com">dataconverter.ti.com</a>
DLP® Products	<a href="http://www.dlp.com">www.dlp.com</a>
DSP	<a href="http://dsp.ti.com">dsp.ti.com</a>
Clocks and Timers	<a href="http://www.ti.com/clocks">www.ti.com/clocks</a>
Interface	<a href="http://interface.ti.com">interface.ti.com</a>
Logic	<a href="http://logic.ti.com">logic.ti.com</a>
Power Mgmt	<a href="http://power.ti.com">power.ti.com</a>
Microcontrollers	<a href="http://microcontroller.ti.com">microcontroller.ti.com</a>
RFID	<a href="http://www.ti-rfid.com">www.ti-rfid.com</a>
OMAP Applications Processors	<a href="http://www.ti.com/omap">www.ti.com/omap</a>
Wireless Connectivity	<a href="http://www.ti.com/wirelessconnectivity">www.ti.com/wirelessconnectivity</a>

### Applications

Automotive and Transportation	<a href="http://www.ti.com/automotive">www.ti.com/automotive</a>
Communications and Telecom	<a href="http://www.ti.com/communications">www.ti.com/communications</a>
Computers and Peripherals	<a href="http://www.ti.com/computers">www.ti.com/computers</a>
Consumer Electronics	<a href="http://www.ti.com/consumer-apps">www.ti.com/consumer-apps</a>
Energy and Lighting	<a href="http://www.ti.com/energy">www.ti.com/energy</a>
Industrial	<a href="http://www.ti.com/industrial">www.ti.com/industrial</a>
Medical	<a href="http://www.ti.com/medical">www.ti.com/medical</a>
Security	<a href="http://www.ti.com/security">www.ti.com/security</a>
Space, Avionics and Defense	<a href="http://www.ti.com/space-avionics-defense">www.ti.com/space-avionics-defense</a>
Video and Imaging	<a href="http://www.ti.com/video">www.ti.com/video</a>

### TI E2E Community

[e2e.ti.com](http://e2e.ti.com)