



### Input/Output Options

Base Part Number	Logic Input
LM5134A	CMOS
LM5134B	TTL

### Truth Table

IN	INB	OUT	PILOT
L	L	L	H
L	H	L	H
H	L	H	L
H	H	L	H

### Connection Diagram

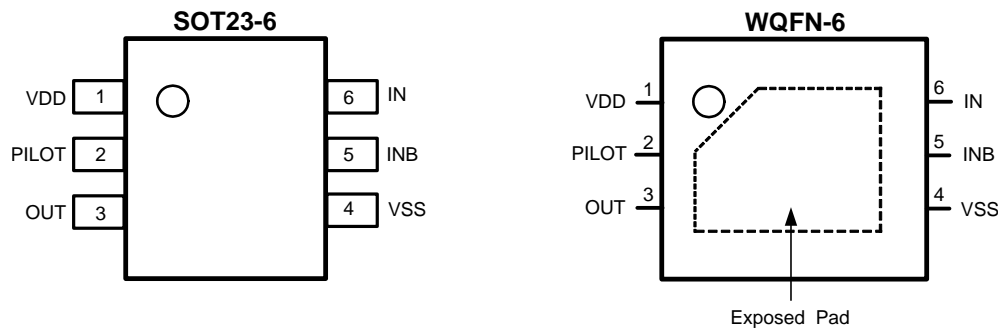

### PIN DESCRIPTIONS

Pin No.	Name	Description	Applications Information
1	VDD	Gate drive supply	Locally decouple to VSS using low ESR/ESL capacitor located as close as possible to the IC.
2	PILOT	Gate drive output for an external turn-off FET	Connect to the gate of a small turn-off MOSFET with a short, low inductance path. The turn-off FET provides a local turn-off path.
3	OUT	Gate drive output for the power FET	Connect to the gate of the power FET with a short, low inductance path. A gate resistor can be used to eliminate potential gate oscillations.
4	VSS	Ground	All signals are referenced to this ground.
5	INB	Inverting logic input	Connect to VSS when not used.
6	IN	Non-inverting logic input	Connect to VDD when not used.
EP	EP	Exposed Pad	It is recommended that the exposed pad on the bottom of the package be soldered to ground plane on the PC board, and that ground plane extend out from beneath the IC to help dissipate heat.



These devices have limited built-in ESD protection. The leads should be shorted together or the device placed in conductive foam during storage or handling to prevent electrostatic damage to the MOS gates.

## Absolute Maximum Ratings <sup>(1)</sup>

VDD to VSS	-0.3V to 14V
IN, INB to VSS	-0.3V to 14V
Storage Temperature Range	-55°C to +150°C
Junction Temperature	+150°C
ESD Rating HBM	2kV

(1) Absolute Maximum Ratings indicate limits beyond which damage to the device may occur. Operating Ratings indicate conditions for which the device is intended to be functional, but does not guarantee specific performance limits. For guaranteed specifications and conditions, see the Electrical Characteristics.

## Recommended Operating Conditions

VDD	+4.0V to 12.6V
Operating Junction Temperature	-40°C to +125°C

## Electrical Characteristics

Limits in standard type are for  $T_J = 25^\circ\text{C}$  only; limits in boldface type apply over the junction temperature ( $T_J$ ) range of  $-40^\circ\text{C}$  to  $+125^\circ\text{C}$ . Minimum and Maximum limits are guaranteed through test, design, or statistical correlation. Typical values represent the most likely parametric norm at  $T_J = 25^\circ\text{C}$ , and are provided for reference purposes only. Unless otherwise specified,  $V_{DD} = +12\text{V}^{(1)}$ .

Symbol	Parameter	Conditions	Min	Typ	Max	Units
<b>POWER SUPPLY</b>						
VDD	VDD Operating Voltage		<b>4.0</b>		<b>12.6</b>	V
UVLO	VDD Undervoltage Lockout	VDD Rising	<b>3.25</b>	3.6	<b>4.00</b>	V
	VDD Undervoltage Lockout Hysteresis			0.36		V
	VDD Undervoltage lockout to Main output delay time	VDD Rising		500		ns
$I_{DD}$	VDD Quiescent Current	IN = INB = VDD		0.8	<b>2</b>	mA
<b>OUTPUT</b>						
$R_{ON-DW}$ (SOT23-6)	Main output Resistance – Pulling Down	VDD = 10V, $I_{OUT} = -100\text{mA}$		0.15	<b>0.45</b>	$\Omega$
		VDD = 4.5V, $I_{OUT} = -100\text{mA}$		0.2	<b>0.5</b>	$\Omega$
$R_{ON-DW}$ (WQFN)	Main output Resistance – Pulling Down	VDD = 10V, $I_{OUT} = -100\text{mA}$		0.2	<b>0.5</b>	$\Omega$
		VDD = 4.5V, $I_{OUT} = -100\text{mA}$		0.25	<b>0.55</b>	$\Omega$
	Power-off Pull Down Resistance	VDD = 0V, $I_{OUT} = -10\text{mA}$		1.5	10	$\Omega$
	Power-off Pull Down Clamp Voltage	VDD = 0V, $I_{OUT} = -10\text{mA}$		0.7	1.0	V
	Peak Sink Current	$C_L = 10,000\text{pF}$		7.6		A
$R_{ON-UP}$ (SOT23-6)	Main output Resistance - Pulling Up	VDD = 10V, $I_{OUT} = 50\text{mA}$		0.7	<b>1.3</b>	$\Omega$
		VDD = 4.5V, $I_{OUT} = 50\text{mA}$		1	<b>1.9</b>	$\Omega$
$R_{ON-UP}$ (WQFN)	Main output Resistance - Pulling Up	VDD = 10V, $I_{OUT} = 50\text{mA}$		0.75	<b>1.2</b>	$\Omega$
		VDD = 4.5V, $I_{OUT} = 50\text{mA}$		1.14	<b>1.85</b>	$\Omega$
	Peak Source Current	$C_L = 10,000\text{pF}$		4.5		A
<b>PILOT</b>						
$R_{ONP-DW}$	PILOT Output Resistance – Pulling Down	VDD = 10V, $I_{OUT} = -100\text{mA}$		3.7	<b>9</b>	$\Omega$
		VDD = 4.5V, $I_{OUT} = -100\text{mA}$		4.7	<b>12</b>	$\Omega$
	Peak Sink Current	$C_L = 330\text{pF}$		820		mA

(1) Min and Max limits are 100% production tested at  $25^\circ\text{C}$ . Limits over the operating temperature range are guaranteed through correlation using Statistical Quality Control (SQC) methods. Limits are used to calculate Average Outgoing Quality Level (AOQL).

## Electrical Characteristics (continued)

Limits in standard type are for  $T_J = 25^\circ\text{C}$  only; limits in boldface type apply over the junction temperature ( $T_J$ ) range of  $-40^\circ\text{C}$  to  $+125^\circ\text{C}$ . Minimum and Maximum limits are guaranteed through test, design, or statistical correlation. Typical values represent the most likely parametric norm at  $T_J = 25^\circ\text{C}$ , and are provided for reference purposes only. Unless otherwise specified,  $V_{DD} = +12\text{V}^{(1)}$ .

Symbol	Parameter	Conditions	Min	Typ	Max	Units
$R_{ONP-UP}$	PILOT output Resistance – Pulling Up	$V_{DD} = 10\text{V}, I_{OUT} = 50\text{mA}$		6	<b>11</b>	$\Omega$
		$V_{DD} = 4.5\text{V}, I_{OUT} = 50\text{mA}$		10.7	<b>20</b>	$\Omega$
	Peak Source Current	$C_L = 330\text{pF}$		660		mA
<b>LOGIC INPUT</b>						
$V_{IH}$	Logic 1 Input Voltage	LM5134A	<b>0.67 x VDD</b>			V
		LM5134B	<b>2.4</b>			V
$V_{IL}$	Logic 0 Input Voltage	LM5134A			<b>0.33 x VDD</b>	V
		LM5134B			<b>0.8</b>	V
$V_{HYS}$	Logic-Input Hysteresis	LM5134A		0.9		V
		LM5134B		0.68		
	Logic-Input Current	INB = VDD or 0		0.001	<b>10</b>	$\mu\text{A}$
<b>THERMAL RESISTANCE</b>						
$\theta_{JA}$	Junction to Ambient	SOT23-6		90		$^\circ\text{C/W}$
		WQFN-6		60		$^\circ\text{C/W}$
<b>SWITCHING CHARACTERISTICS FOR VDD = +10V</b>						
$t_R$	OUT Rise Time	$C_L = 1000\text{pF}$		3		ns
		$C_L = 5000\text{pF}$		10		ns
		$C_L = 10,000\text{pF}$		20		ns
$t_F$	OUT Fall Time	$C_L = 1000\text{pF}$		2		ns
		$C_L = 5000\text{pF}$		4.7		ns
		$C_L = 10,000\text{pF}$		7.2		ns
$t_{D-ON}$	OUT Turn-On Propagation Delay	$C_L = 1000\text{pF}$		17	<b>40</b>	ns
$t_{D-OFF}$	OUT Turn-Off Propagation Delay	$C_L = 1000\text{pF}$		12	<b>25</b>	ns
	Main Output Break-Before-Make Time			2.5		ns
$t_{PR}$	PILOT Rise Time	$C_L = 330\text{pF}$		5.3		ns
$t_{PF}$	PILOT Fall Time	$C_L = 330\text{pF}$		3.9		ns
$t_{PD-ON}$	OUT Turn-Off to PILOT Turn-On Propagation Delay	$C_L = 330\text{pF}$		4.2		ns
$t_{PD-OFF}$	PILOT Turn-Off to OUT Turn-On Propagation Delay	$C_L = 330\text{pF}$		6.4		ns
<b>SWITCHING CHARACTERISTICS FOR VDD = +4.5V</b>						
$t_R$	Rise Time	$C_L = 1000\text{pF}$		5		ns
		$C_L = 5000\text{pF}$		14		ns
		$C_L = 10,000\text{pF}$		24		ns
$t_F$	Fall Time	$C_L = 1000\text{pF}$		2.3		ns
		$C_L = 5000\text{pF}$		5.4		ns
		$C_L = 10,000\text{pF}$		7.2		ns
$t_{D-ON}$	OUT Turn-On Propagation Delay	$C_L = 1000\text{pF}$		26	<b>50</b>	ns
$t_{D-OFF}$	OUT Turn-Off Propagation Delay	$C_L = 1000\text{pF}$		20	<b>45</b>	ns
	Main output Break-Before-Make Time			4.2		ns
$t_{PR}$	PILOT Rise Time	$C_L = 330\text{pF}$		9.6		ns
$t_{PF}$	PILOT Fall Time	$C_L = 330\text{pF}$		3.7		ns

**Electrical Characteristics (continued)**

Limits in standard type are for  $T_J = 25^\circ\text{C}$  only; limits in boldface type apply over the junction temperature ( $T_J$ ) range of  $-40^\circ\text{C}$  to  $+125^\circ\text{C}$ . Minimum and Maximum limits are guaranteed through test, design, or statistical correlation. Typical values represent the most likely parametric norm at  $T_J = 25^\circ\text{C}$ , and are provided for reference purposes only. Unless otherwise specified,  $V_{DD} = +12\text{V}^{(1)}$ .

Symbol	Parameter	Conditions	Min	Typ	Max	Units
$t_{PD-ON}$	OUT Turn-Off to PILOT Turn-On Propagation Delay	$C_L = 330\text{pF}$		7.5		ns
$t_{PD-OFF}$	PILOT Turn-Off to OUT Turn-On Propagation Delay	$C_L = 330\text{pF}$		11.8		ns

**TIMING DIAGRAM**

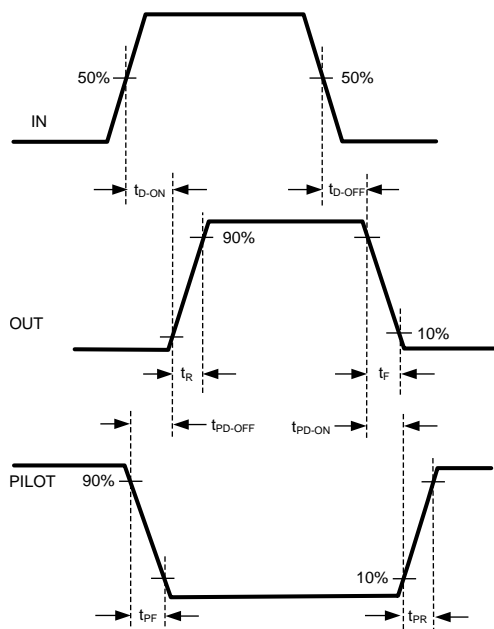

**Figure 2.**

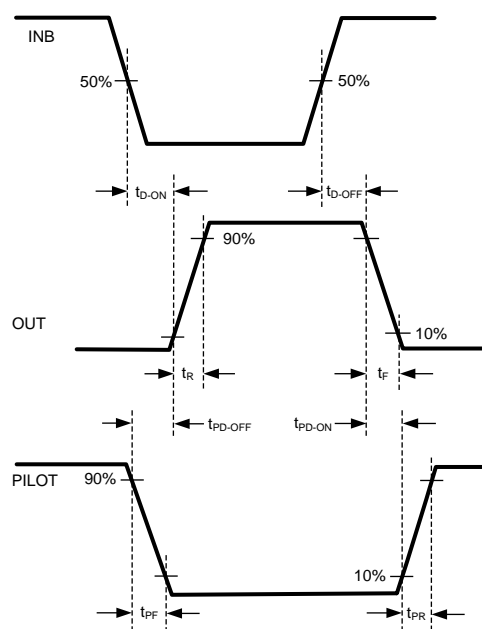

**Figure 3.**

**TYPICAL PERFORMANCE CHARACTERISTICS**

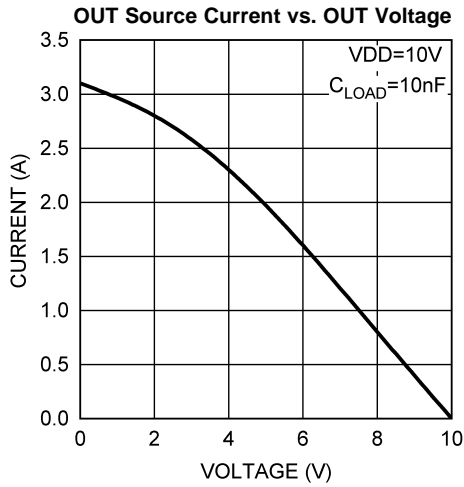

Figure 4.

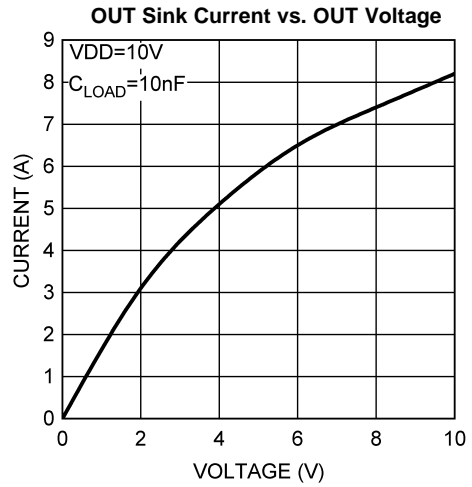

Figure 5.

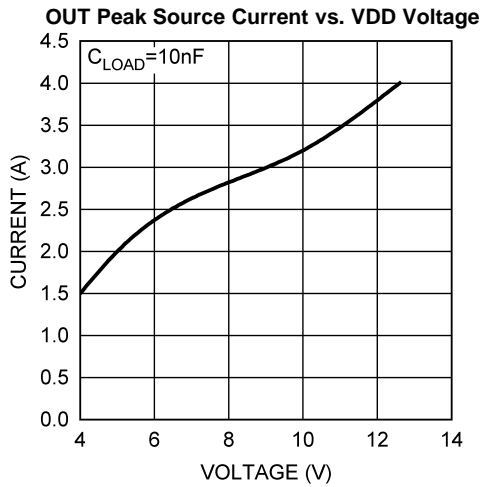

Figure 6.

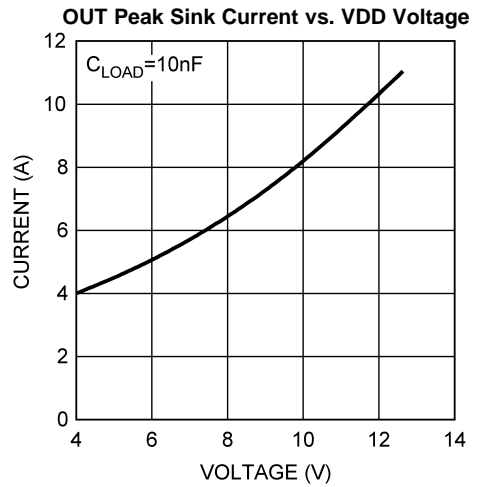

Figure 7.

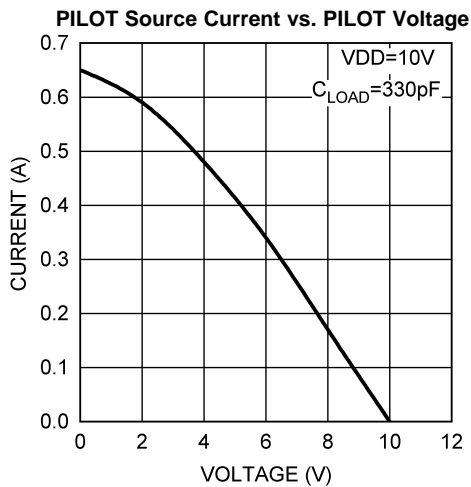

Figure 8.

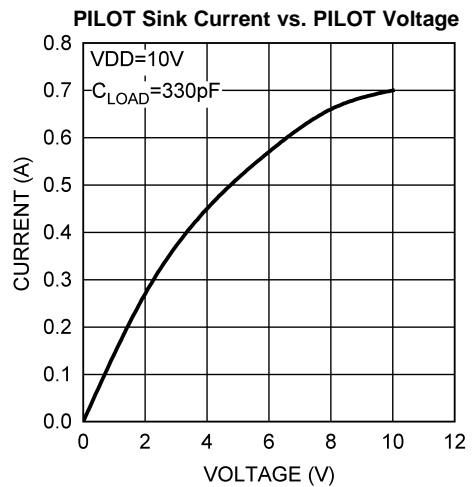

Figure 9.

**TYPICAL PERFORMANCE CHARACTERISTICS (continued)**

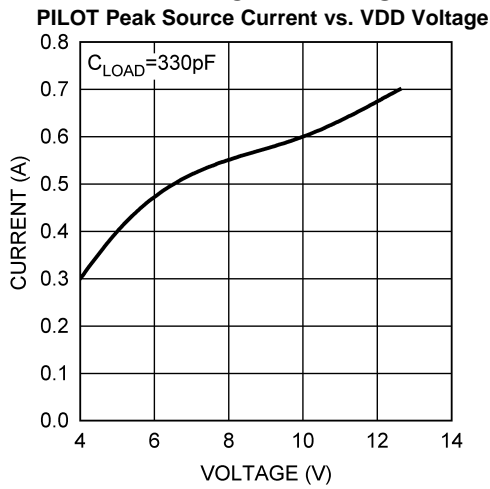

Figure 10.

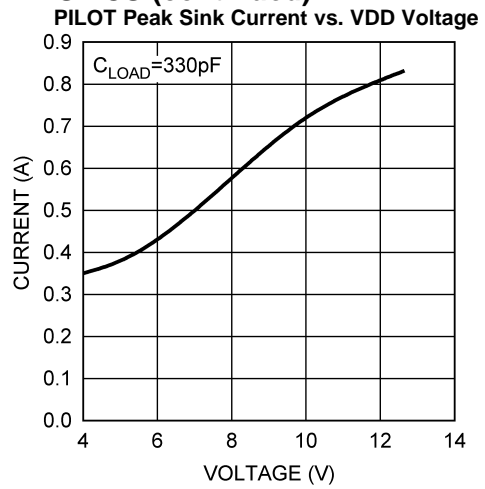

Figure 11.

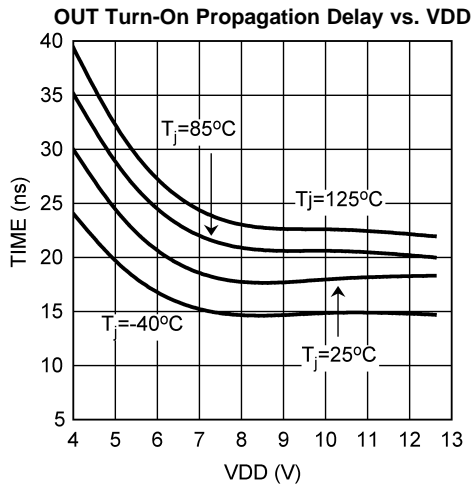

Figure 12.

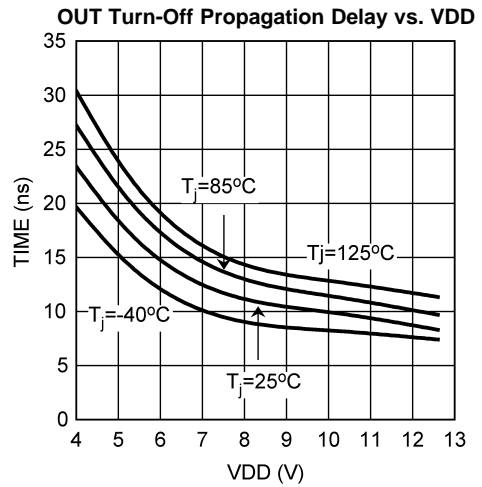

Figure 13.

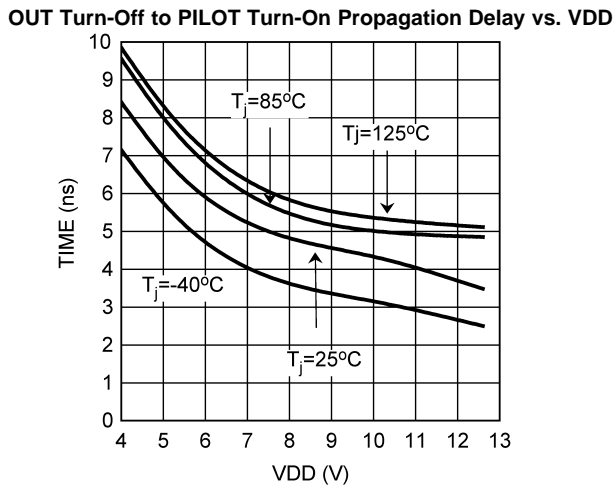

Figure 14.

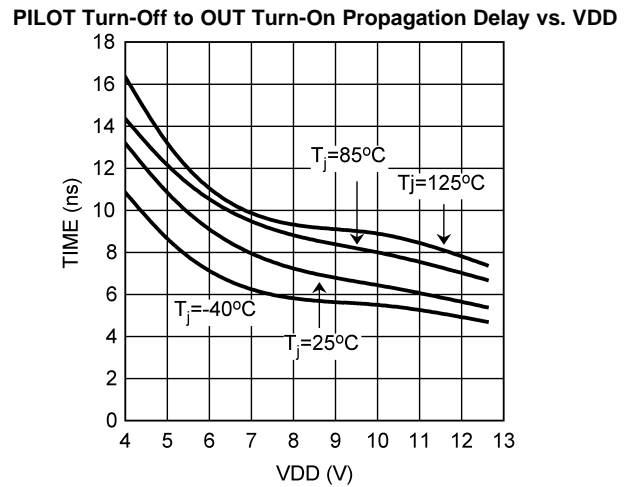

Figure 15.

**TYPICAL PERFORMANCE CHARACTERISTICS (continued)**

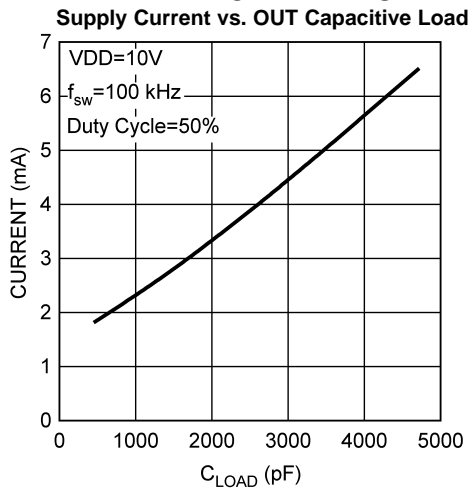

Figure 16.

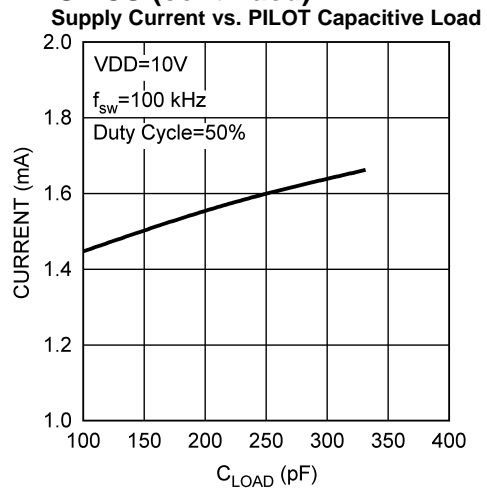

Figure 17.

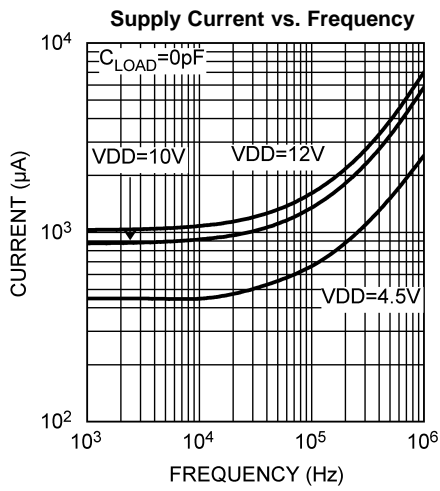

Figure 18.

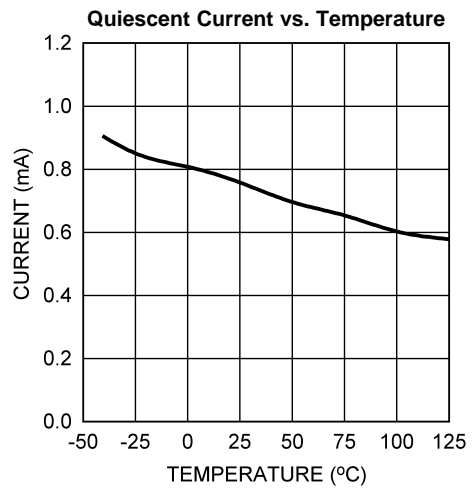

Figure 19.

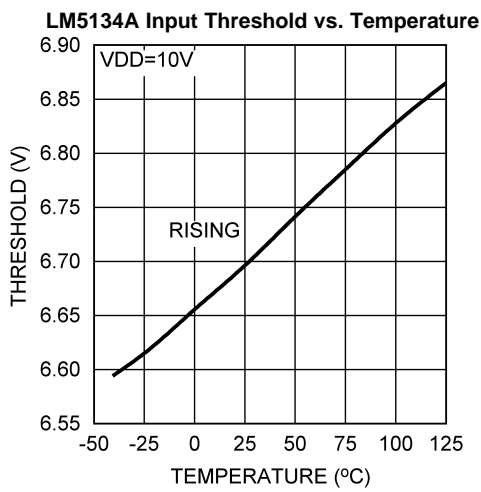

Figure 20.

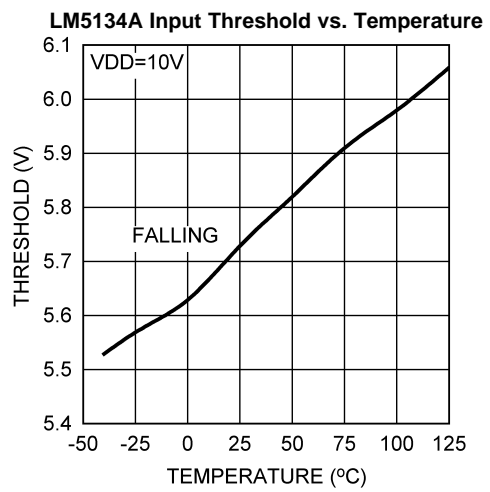

Figure 21.

**TYPICAL PERFORMANCE CHARACTERISTICS (continued)**

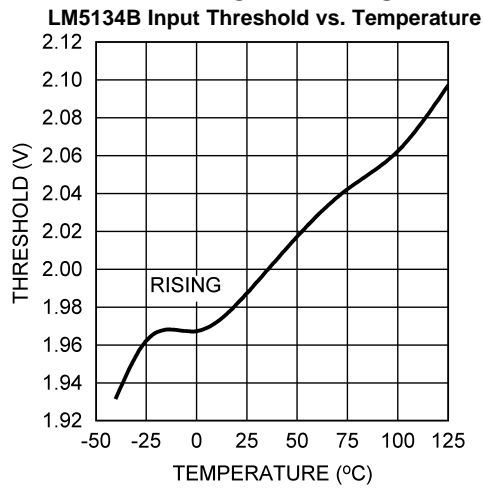

Figure 22.

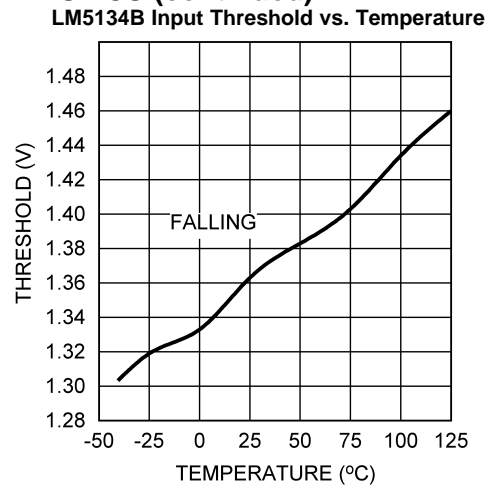

Figure 23.

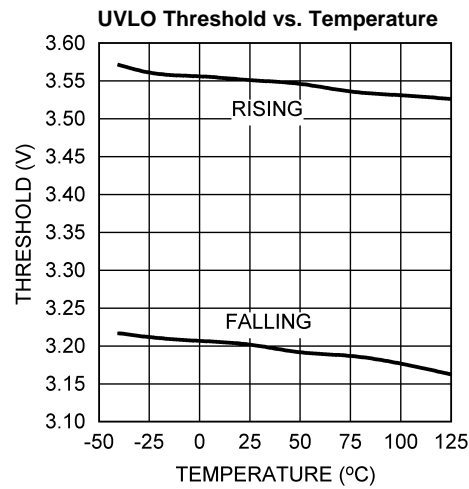

Figure 24.

## DETAILED OPERATING DESCRIPTION

The LM5134 is a single low-side gate driver with one main output, OUT, and a complementary output PILOT. The OUT pin has high 7.6A/4.5A peak sink/source current and can be used to drive large power MOSFETs or multiple MOSFETs in parallel. The PILOT pin has 820mA/660mA peak sink/source current, and is intended to drive an external turn-off MOSFET, as shown in [Figure 1](#). The external turn-off FET can be placed close to the power MOSFETs to minimize the loop inductance, and therefore helps eliminate stray inductance induced oscillations or undesired turn-on. This feature also provides the flexibility to adjust turn-on and turn-off speed independently.

When using the external turn-off switch, it is important to prevent the potential shoot-through between the external turn-off switch and the LM5134 internal pull-up switch. The propagation delay,  $T_{PD-ON}$  and  $T_{PD-OFF}$ , has been implemented in the LM5134 between the PILOT and the OUT pins, as depicted in the timing diagram. The turn-on delay  $T_{PD-ON}$  is designed to be shorter than the turn-off delay  $T_{PD-OFF}$  because the rising time of the external turn-off switch can attribute to the additional delay time. It is also desirable to minimize  $T_{PD-ON}$  to favor the fast turn-off of the power MOSFET.

The LM5134 offers both inverting and non-inverting inputs to satisfy requirements for inverting and non-inverting gate drive signals in a single device type. Inputs of the LM5134 are TTL and CMOS Logic compatible and can withstand input voltages up to 14V regardless of the VDD voltage. This allows inputs of the LM5134 to be connected directly to most PWM controllers.

The LM5134 includes an Under-voltage Lockout (UVLO) circuit. When the VDD voltage is below the UVLO threshold voltage, the IN and INB inputs are ignored, and if there is sufficient VDD voltage, the OUT is pulled low. In addition, the LM5134 has an internal PNP transistor in parallel with the output NMOS. Under the UVLO condition, the PNP transistor will be on and clamp the OUT voltage below 1V. This feature ensures the OUT remains low even with insufficient VDD voltage.

### Application Information

#### PILOT MOSFET Selection

In general, a small sized 20V MOSFET with logic level gates can be used as the external turn-off switch. To achieve a fast switching speed and avoid the potential shoot-through, it is suggested to select a MOSFET with the total gate charge less than 3nC. It is good practice to verify that no shoot-through occurs for the entire operating temperature range. In addition, a small  $R_{ds(on)}$  is preferred to obtain the strong sink current capability. The power losses of the PILOT MOSFET can be estimated as:

$$P_g = \frac{1}{2} \times Q_{go} \times VDD \times F_{sw} \quad (1)$$

where  $Q_{go}$  is the total input gate charge of the power MOSFET.

#### Power Dissipation

It is important to keep the power consumption of the driver below the maximum power dissipation limit of the package at the operating temperature. The total power dissipation of the LM5134 is the sum of the gate charge losses and the losses in the driver due to the internal CMOS stages used to buffer the output as well as the power losses associated with the quiescent current.

The gate charge losses include the power MOSFET gate charge losses as well as the PILOT FET gate charge losses and can be calculated as follows:

$$P_g = (Q_{go} + Q_{gp}) \times VDD \times F_{sw} \quad (2)$$

Or

$$P_g = (C_o + C_p) \times VDD^2 \times F_{sw} \quad (3)$$

where  $F_{sw}$  is switching frequency,  $Q_{go}$  is the total input gate charge of the power MOSFET,  $Q_{gp}$  is the total input gate charge of the PILOT MOSFET.  $C_o$  and  $C_p$  are the load capacitance at OUT and PILOT outputs respectively. It should be noted that due to the use of an external turn-off switch, part of the gate charge losses are dissipated in the external turn-off switch. Therefore, the actual gate charge losses dissipated in the LM5134 is less than predicted by the above expressions. However, they are a good conservative design estimate.

The power dissipation associated with the internal circuit operation of the driver can be estimated with the characterization curves of the LM5134. For a given ambient temperature, the maximum allowable power losses of the IC can be defined as:

$$P = \frac{(T_J - T_A)}{\theta_{JA}} \quad (4)$$

where P is the total power dissipation of the driver.

## Layout Considerations

Attention must be given to board layout when using LM5134. Some important considerations include:

1. The first priority in designing the layout of the driver is to confine the high peak currents that charge and discharge the FETs gate into a minimal physical area. This will decrease the loop inductance and minimize noise issues on the gate.
2. To reduce the loop inductance, the driver should be placed as close as possible to the FETs. The gate trace to and from the FETs are recommended to be placed closely side by side, or directly on top of one another.
3. A low ESR/ESL ceramic capacitor must be connected close to the IC, between VDD and VSS pins to support the high peak current being drawn from VDD during turn-on of the FETs. It is most desirable to place the VDD decoupling capacitor on the same side of the PC board as the driver. The inductance of via holes can impose excessive ringing on the IC pins.
4. The parasitic source inductance, along with the gate capacitor and the driver pull-down path, can form a LCR resonant tank, resulting in gate voltage oscillations. An optional resistor or ferrite bead can be used to damp the ringing.

**PACKAGING INFORMATION**

Orderable Device	Status (1)	Package Type	Package Drawing	Pins	Package Qty	Eco Plan (2)	Lead/Ball Finish	MSL Peak Temp (3)	Op Temp (°C)	Top-Side Markings (4)	Samples
LM5134AMF/NOPB	ACTIVE	SOT-23	DBV	6	1000	Green (RoHS & no Sb/Br)	SN	Level-3-260C-168 HR		SK7A	<a href="#">Samples</a>
LM5134AMFX/NOPB	ACTIVE	SOT-23	DBV	6	3000	Green (RoHS & no Sb/Br)	SN	Level-3-260C-168 HR		SK7A	<a href="#">Samples</a>
LM5134ASD/NOPB	ACTIVE	WSON	NGG	6	1000	Green (RoHS & no Sb/Br)	CU SN	Level-1-260C-UNLIM		5134A	<a href="#">Samples</a>
LM5134ASDX/NOPB	ACTIVE	WSON	NGG	6	4500	Green (RoHS & no Sb/Br)	CU SN	Level-1-260C-UNLIM		5134A	<a href="#">Samples</a>
LM5134BMF/NOPB	ACTIVE	SOT-23	DBV	6	1000	Green (RoHS & no Sb/Br)	SN	Level-3-260C-168 HR		SK7B	<a href="#">Samples</a>
LM5134BMFX/NOPB	ACTIVE	SOT-23	DBV	6	3000	Green (RoHS & no Sb/Br)	SN	Level-3-260C-168 HR		SK7B	<a href="#">Samples</a>
LM5134BSD/NOPB	ACTIVE	WSON	NGG	6	1000	Green (RoHS & no Sb/Br)	CU SN	Level-1-260C-UNLIM		5134B	<a href="#">Samples</a>
LM5134BSDX/NOPB	ACTIVE	WSON	NGG	6	4500	Green (RoHS & no Sb/Br)	CU SN	Level-1-260C-UNLIM		5134B	<a href="#">Samples</a>

(1) The marketing status values are defined as follows:

**ACTIVE:** Product device recommended for new designs.

**LIFEBUY:** TI has announced that the device will be discontinued, and a lifetime-buy period is in effect.

**NRND:** Not recommended for new designs. Device is in production to support existing customers, but TI does not recommend using this part in a new design.

**PREVIEW:** Device has been announced but is not in production. Samples may or may not be available.

**OBSOLETE:** TI has discontinued the production of the device.

(2) Eco Plan - The planned eco-friendly classification: Pb-Free (RoHS), Pb-Free (RoHS Exempt), or Green (RoHS & no Sb/Br) - please check <http://www.ti.com/productcontent> for the latest availability information and additional product content details.

**TBD:** The Pb-Free/Green conversion plan has not been defined.

**Pb-Free (RoHS):** TI's terms "Lead-Free" or "Pb-Free" mean semiconductor products that are compatible with the current RoHS requirements for all 6 substances, including the requirement that lead not exceed 0.1% by weight in homogeneous materials. Where designed to be soldered at high temperatures, TI Pb-Free products are suitable for use in specified lead-free processes.

**Pb-Free (RoHS Exempt):** This component has a RoHS exemption for either 1) lead-based flip-chip solder bumps used between the die and package, or 2) lead-based die adhesive used between the die and leadframe. The component is otherwise considered Pb-Free (RoHS compatible) as defined above.

**Green (RoHS & no Sb/Br):** TI defines "Green" to mean Pb-Free (RoHS compatible), and free of Bromine (Br) and Antimony (Sb) based flame retardants (Br or Sb do not exceed 0.1% by weight in homogeneous material)

(3) MSL, Peak Temp. -- The Moisture Sensitivity Level rating according to the JEDEC industry standard classifications, and peak solder temperature.

<sup>(4)</sup> Only one of markings shown within the brackets will appear on the physical device.

**Important Information and Disclaimer:** The information provided on this page represents TI's knowledge and belief as of the date that it is provided. TI bases its knowledge and belief on information provided by third parties, and makes no representation or warranty as to the accuracy of such information. Efforts are underway to better integrate information from third parties. TI has taken and continues to take reasonable steps to provide representative and accurate information but may not have conducted destructive testing or chemical analysis on incoming materials and chemicals. TI and TI suppliers consider certain information to be proprietary, and thus CAS numbers and other limited information may not be available for release.

In no event shall TI's liability arising out of such information exceed the total purchase price of the TI part(s) at issue in this document sold by TI to Customer on an annual basis.

**TAPE AND REEL INFORMATION**

**QUADRANT ASSIGNMENTS FOR PIN 1 ORIENTATION IN TAPE**

\*All dimensions are nominal

Device	Package Type	Package Drawing	Pins	SPQ	Reel Diameter (mm)	Reel Width W1 (mm)	A0 (mm)	B0 (mm)	K0 (mm)	P1 (mm)	W (mm)	Pin1 Quadrant
LM5134AMF/NOPB	SOT-23	DBV	6	1000	178.0	8.4	3.2	3.2	1.4	4.0	8.0	Q3
LM5134AMFX/NOPB	SOT-23	DBV	6	3000	178.0	8.4	3.2	3.2	1.4	4.0	8.0	Q3
LM5134ASD/NOPB	WSON	NGG	6	1000	178.0	12.4	3.3	3.3	1.0	8.0	12.0	Q1
LM5134ASDX/NOPB	WSON	NGG	6	4500	330.0	12.4	3.3	3.3	1.0	8.0	12.0	Q1
LM5134BMF/NOPB	SOT-23	DBV	6	1000	178.0	8.4	3.2	3.2	1.4	4.0	8.0	Q3
LM5134BMFX/NOPB	SOT-23	DBV	6	3000	178.0	8.4	3.2	3.2	1.4	4.0	8.0	Q3
LM5134BSD/NOPB	WSON	NGG	6	1000	178.0	12.4	3.3	3.3	1.0	8.0	12.0	Q1
LM5134BSDX/NOPB	WSON	NGG	6	4500	330.0	12.4	3.3	3.3	1.0	8.0	12.0	Q1

**TAPE AND REEL BOX DIMENSIONS**

\*All dimensions are nominal

Device	Package Type	Package Drawing	Pins	SPQ	Length (mm)	Width (mm)	Height (mm)
LM5134AMF/NOPB	SOT-23	DBV	6	1000	203.0	190.0	41.0
LM5134AMFX/NOPB	SOT-23	DBV	6	3000	203.0	190.0	41.0
LM5134ASD/NOPB	WSON	NGG	6	1000	203.0	190.0	41.0
LM5134ASDX/NOPB	WSON	NGG	6	4500	349.0	337.0	45.0
LM5134BMF/NOPB	SOT-23	DBV	6	1000	203.0	190.0	41.0
LM5134BMFX/NOPB	SOT-23	DBV	6	3000	203.0	190.0	41.0
LM5134BSD/NOPB	WSON	NGG	6	1000	203.0	190.0	41.0
LM5134BSDX/NOPB	WSON	NGG	6	4500	349.0	337.0	45.0

DBV (R-PDSO-G6)

PLASTIC SMALL-OUTLINE PACKAGE

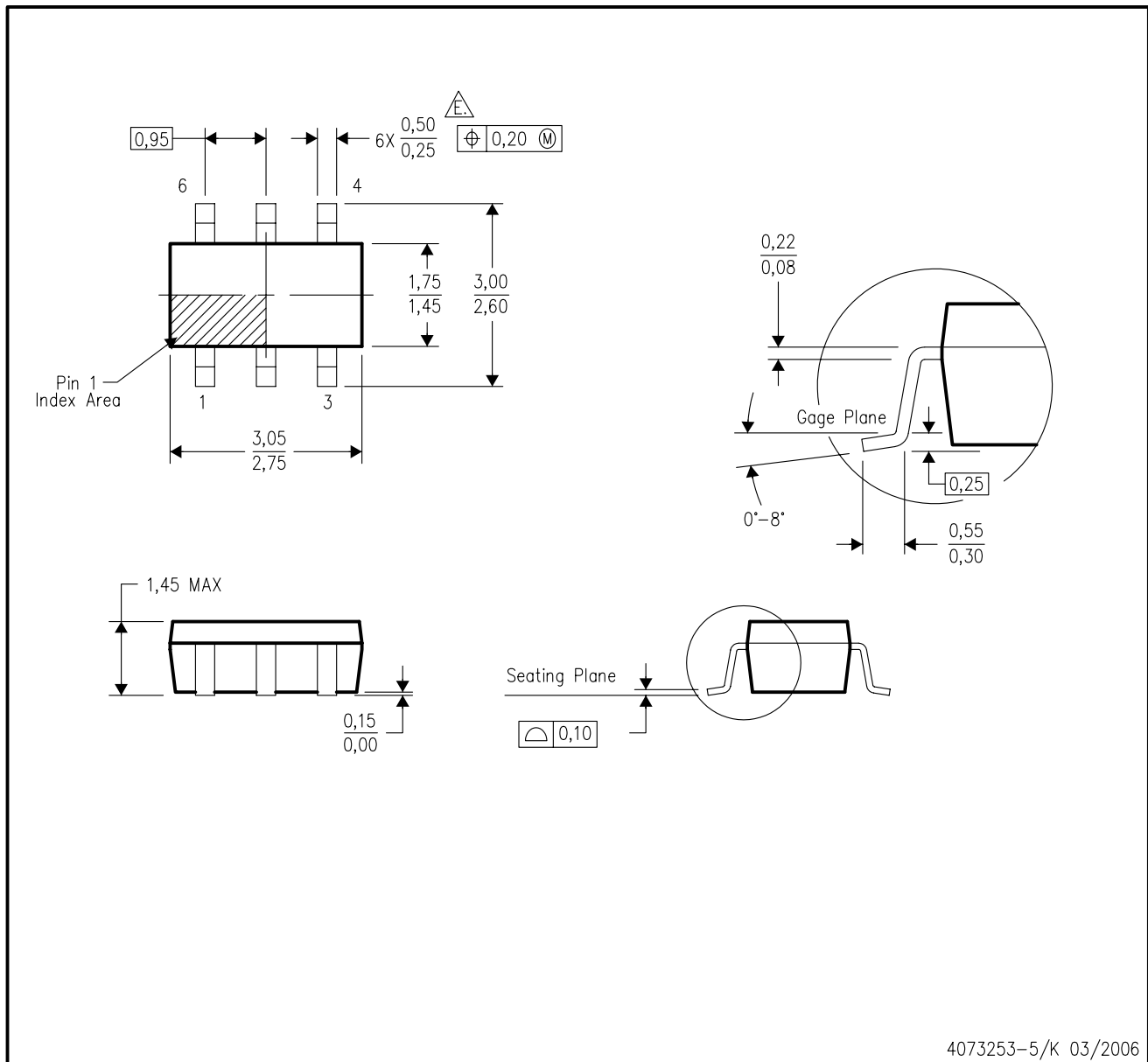

- NOTES:
- A. All linear dimensions are in millimeters.
  - B. This drawing is subject to change without notice.
  - C. Body dimensions do not include mold flash or protrusion. Mold flash and protrusion shall not exceed 0.15 per side.
  - D. Leads 1,2,3 may be wider than leads 4,5,6 for package orientation.
- $\triangle E$  Falls within JEDEC MO-178 Variation AB, except minimum lead width.

NGG0006A

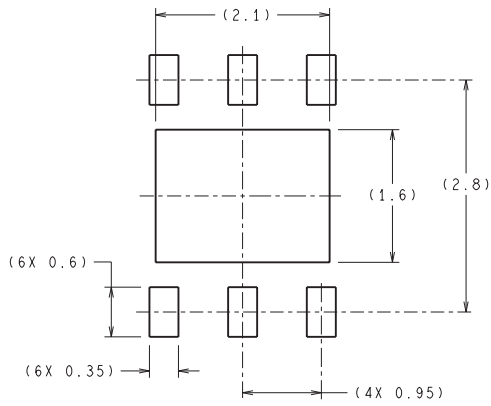

RECOMMENDED LAND PATTERN

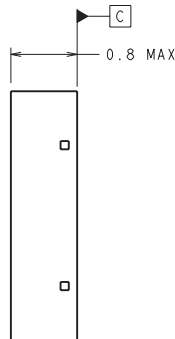
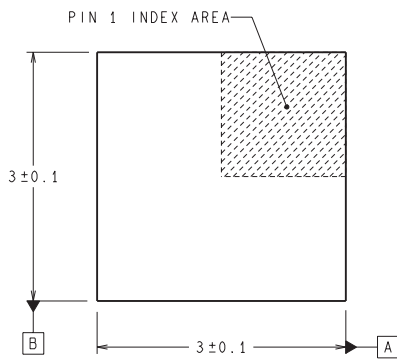

DIMENSIONS ARE IN MILLIMETERS  
DIMENSION IN ( ) FOR REFERENCE ONLY

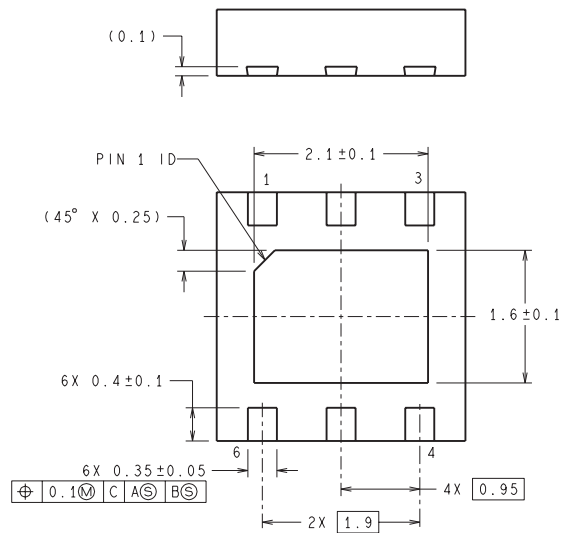

SDE06A (Rev A)

## IMPORTANT NOTICE

Texas Instruments Incorporated and its subsidiaries (TI) reserve the right to make corrections, enhancements, improvements and other changes to its semiconductor products and services per JESD46, latest issue, and to discontinue any product or service per JESD48, latest issue. Buyers should obtain the latest relevant information before placing orders and should verify that such information is current and complete. All semiconductor products (also referred to herein as "components") are sold subject to TI's terms and conditions of sale supplied at the time of order acknowledgment.

TI warrants performance of its components to the specifications applicable at the time of sale, in accordance with the warranty in TI's terms and conditions of sale of semiconductor products. Testing and other quality control techniques are used to the extent TI deems necessary to support this warranty. Except where mandated by applicable law, testing of all parameters of each component is not necessarily performed.

TI assumes no liability for applications assistance or the design of Buyers' products. Buyers are responsible for their products and applications using TI components. To minimize the risks associated with Buyers' products and applications, Buyers should provide adequate design and operating safeguards.

TI does not warrant or represent that any license, either express or implied, is granted under any patent right, copyright, mask work right, or other intellectual property right relating to any combination, machine, or process in which TI components or services are used. Information published by TI regarding third-party products or services does not constitute a license to use such products or services or a warranty or endorsement thereof. Use of such information may require a license from a third party under the patents or other intellectual property of the third party, or a license from TI under the patents or other intellectual property of TI.

Reproduction of significant portions of TI information in TI data books or data sheets is permissible only if reproduction is without alteration and is accompanied by all associated warranties, conditions, limitations, and notices. TI is not responsible or liable for such altered documentation. Information of third parties may be subject to additional restrictions.

Resale of TI components or services with statements different from or beyond the parameters stated by TI for that component or service voids all express and any implied warranties for the associated TI component or service and is an unfair and deceptive business practice. TI is not responsible or liable for any such statements.

Buyer acknowledges and agrees that it is solely responsible for compliance with all legal, regulatory and safety-related requirements concerning its products, and any use of TI components in its applications, notwithstanding any applications-related information or support that may be provided by TI. Buyer represents and agrees that it has all the necessary expertise to create and implement safeguards which anticipate dangerous consequences of failures, monitor failures and their consequences, lessen the likelihood of failures that might cause harm and take appropriate remedial actions. Buyer will fully indemnify TI and its representatives against any damages arising out of the use of any TI components in safety-critical applications.

In some cases, TI components may be promoted specifically to facilitate safety-related applications. With such components, TI's goal is to help enable customers to design and create their own end-product solutions that meet applicable functional safety standards and requirements. Nonetheless, such components are subject to these terms.

No TI components are authorized for use in FDA Class III (or similar life-critical medical equipment) unless authorized officers of the parties have executed a special agreement specifically governing such use.

Only those TI components which TI has specifically designated as military grade or "enhanced plastic" are designed and intended for use in military/aerospace applications or environments. Buyer acknowledges and agrees that any military or aerospace use of TI components which have **not** been so designated is solely at the Buyer's risk, and that Buyer is solely responsible for compliance with all legal and regulatory requirements in connection with such use.

TI has specifically designated certain components as meeting ISO/TS16949 requirements, mainly for automotive use. In any case of use of non-designated products, TI will not be responsible for any failure to meet ISO/TS16949.

### Products

Audio	<a href="http://www.ti.com/audio">www.ti.com/audio</a>
Amplifiers	<a href="http://amplifier.ti.com">amplifier.ti.com</a>
Data Converters	<a href="http://dataconverter.ti.com">dataconverter.ti.com</a>
DLP® Products	<a href="http://www.dlp.com">www.dlp.com</a>
DSP	<a href="http://dsp.ti.com">dsp.ti.com</a>
Clocks and Timers	<a href="http://www.ti.com/clocks">www.ti.com/clocks</a>
Interface	<a href="http://interface.ti.com">interface.ti.com</a>
Logic	<a href="http://logic.ti.com">logic.ti.com</a>
Power Mgmt	<a href="http://power.ti.com">power.ti.com</a>
Microcontrollers	<a href="http://microcontroller.ti.com">microcontroller.ti.com</a>
RFID	<a href="http://www.ti-rfid.com">www.ti-rfid.com</a>
OMAP Applications Processors	<a href="http://www.ti.com/omap">www.ti.com/omap</a>
Wireless Connectivity	<a href="http://www.ti.com/wirelessconnectivity">www.ti.com/wirelessconnectivity</a>

### Applications

Automotive and Transportation	<a href="http://www.ti.com/automotive">www.ti.com/automotive</a>
Communications and Telecom	<a href="http://www.ti.com/communications">www.ti.com/communications</a>
Computers and Peripherals	<a href="http://www.ti.com/computers">www.ti.com/computers</a>
Consumer Electronics	<a href="http://www.ti.com/consumer-apps">www.ti.com/consumer-apps</a>
Energy and Lighting	<a href="http://www.ti.com/energy">www.ti.com/energy</a>
Industrial	<a href="http://www.ti.com/industrial">www.ti.com/industrial</a>
Medical	<a href="http://www.ti.com/medical">www.ti.com/medical</a>
Security	<a href="http://www.ti.com/security">www.ti.com/security</a>
Space, Avionics and Defense	<a href="http://www.ti.com/space-avionics-defense">www.ti.com/space-avionics-defense</a>
Video and Imaging	<a href="http://www.ti.com/video">www.ti.com/video</a>

### TI E2E Community

[e2e.ti.com](http://e2e.ti.com)