

LM494

Pulse Width Modulated Control Circuit

General Description

The LM494 is a monolithic integrated circuit which includes all the necessary building blocks for the design of pulse width modulated (PWM) switching power supplies, including push-pull, bridge and series configurations. The device can operate at switching frequencies between 1.0 kHz and 300 kHz and output voltages up to 40V. The operating temperature range specified for the LM494C is 0°C to 70°C and for the LM494V is -40°C to +85°C.

Features

- Uncommitted output transistors capable of 200 mA source or sink
- On-chip error amplifiers
- On-chip 5.0V reference
- Internal protection from double pulsing of outputs with narrow pulse widths or with supply voltages below specified limits
- Dead time control comparator
- Output control selects single ended or push-pull operation
- Easily synchronized (slaved) to other circuits

Block Diagram

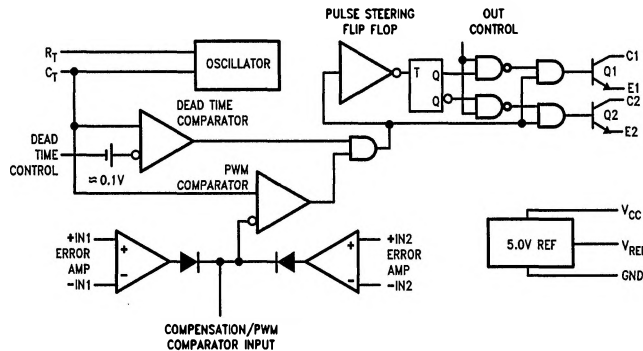

TL/H/10056-2

Connection Diagram

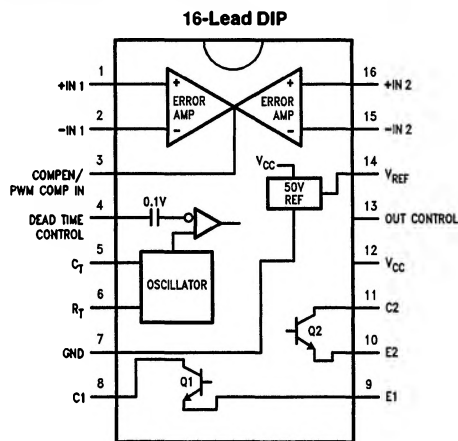
Top View

TL/H/10056-1

Ordering Information

Device Code	Package Code	Package Description
LM494IN	N16A	Molded DIP
LM494CJ	J16A	Ceramic DIP
LM494CN	N16A	Molded DIP

Absolute Maximum Ratings

If Military/Aerospace specified devices are required, please contact the National Semiconductor Sales Office/Distributors for availability and specifications.

Storage Temperature Range		
Ceramic DIP		-65°C to +175°C
Molded DIP		-65°C to +150°C
Operating Temperature Range		
Industrial (LM494I)		-40°C to +85°C
Commercial (LM494C)		0°C to +70°C
Lead Temperature		
Ceramic DIP (Soldering, 60 sec.)		300°C
Molded DIP (Soldering, 10 sec.)		265°C
Internal Power Dissipation (Notes 1, 2)		
16L-Ceramic DIP		1.50W
16L-Molded DIP		1.04W
Supply Voltage		42V
Voltage from Any Lead to Ground (except Lead 8 and Lead 11)		$V_{CC} + 0.3V$

Output Collector Voltage	42V
Peak Collector Current (I_{C1} and I_{C2})	250 mA
ESD Susceptibility	(to be determined)

Recommended Operating Conditions

Power Supply Voltage (V_{CC})	7.0V to 40V
Voltage on Any Lead except Leads 8 and 11 (Referenced to Ground) (V_I)	
	-0.3V to $V_{CC} + 0.3V$
Output Voltage Collector (V_{C1}, V_{C2})	-0.3V to 40V
Output Collector Current (I_{C1}, I_{C2})	200 mA
Timing Capacitor (C_T)	470 pF to 10 μ F
Timing Resistor (R_T)	1.8 k Ω to 500 k Ω
Oscillator Frequency (f_{OSC})	1.0 kHz to 300 kHz

LM494

Electrical Characteristics

$T_A = 0^\circ\text{C}$ to $+70^\circ\text{C}$ for the LM494C, $T_A = -40^\circ\text{C}$ to $+85^\circ\text{C}$ for the LM494I, $V_{CC} = 15V$, $f_{OSC} = 10$ kHz, unless otherwise specified

Symbol	Parameter	Conditions	Min	Typ	Max	Units
REFERENCE SECTION						
V_{REF}	Reference Voltage (Note 3)	$I_{REF} = 1.0$ mA	4.75	5.0	5.25	V
Reg_{LINE}	Line Regulation of Reference Voltage	$7.0V \leq V_{CC} \leq 40V$		2.0	25	mV
TCV_{REF}	Temperature Coefficient of Reference Voltage	$0^\circ\text{C} \leq T_A \leq 70^\circ\text{C}$		0.01	0.03	%/ $^\circ\text{C}$
Reg_{LOAD}	Load Regulation of Reference Voltage	1.0 mA $\leq I_{REF} \leq 10$ mA		1.0	15	mV
I_{OS}	Output Short Circuit Current	$V_{REF} = 0V$		10	35	mA
		$0^\circ\text{C} \leq T_A \leq +70^\circ\text{C}$			50	
		$-40^\circ\text{C} \leq T_A \leq +85^\circ\text{C}$		35		
OSCILLATOR SECTION						
f_{OSC}	Oscillator Frequency (Figure 10)	$C_T = 0.01$ μ F, $R_T = 12$ k Ω		10		kHz
Δf_{OSC}	Oscillator Frequency Change	$C_T = 0.01$ μ F, $R_T = 12$ k Ω	$0^\circ\text{C} \leq T_A \leq +70^\circ\text{C}$		2.0	%
			$-40^\circ\text{C} \leq T_A \leq +85^\circ\text{C}$		2.0	
DEAD TIME CONTROL SECTION						
$I_{IB}(DT)$	Input Bias Current	$V_{CC} = 15V, 0V \leq V_4 \leq 5.25V$		-2.0	-10	μ A
$DC_{(Max)}$	Maximum Duty Cycle, Each Output	$V_{CC} = 15V$, Lead 4 = 0V, Output Control = V_{REF}	45			%
$V_{TH(in)}$	Input Threshold Voltage	Zero Duty Cycle		3.0	3.3	V
		Maximum Duty Cycle	0			
ERROR AMPLIFIER SECTIONS						
V_{IO}	Input Offset Voltage	$V_3 = 2.5V$		2.0	10	mV
I_{IO}	Input Offset Current	$V_3 = 2.5V$		25	250	nA
I_{IB}	Input Bias Current	$V_3 = 2.5V$		0.2	1.0	μ A
V_{ICR}	Input Common Mode Voltage Range	$7.0V \leq V_{CC} \leq 40V$	-0.3		V_{CC}	V
A_{VS}	Large Signal Voltage Gain	$0.5V \leq V_3 \leq 3.5V$	60	74		dB
BW	Bandwidth			650		kHz

LM494**Electrical Characteristics**

$T_A = 0^\circ\text{C}$ to $+70^\circ\text{C}$ for the LM494C, $T_A = -40^\circ\text{C}$ to $+85^\circ\text{C}$ for the LM494I,
 $V_{CC} = 15\text{V}$, $f_{OSC} = 10\text{kHz}$, unless otherwise specified (Continued)

Symbol	Parameter	Conditions	Min	Typ	Max	Units	
PWM COMPARATOR SECTION (Figure 9)							
V_{THI}	Inhibit Threshold Voltage	Zero Duty Cycle		4.0	4.5	V	
I_{O^-}	Output Sink Current (Note 4)	$0.5\text{V} \leq V_3 \leq 3.5\text{V}$	-0.2	-0.6		mA	
I_{O^+}	Output Source Current (Note 4)	$0.5\text{V} \leq V_3 \leq 3.5\text{V}$	2.0			mA	
OUTPUT SECTION							
$V_{CE(sat)}$	Output Saturation Voltage Common Emitter Configuration (Figure 3)	$V_E = 0\text{V}$, $I_C = 200\text{mA}$	$0^\circ\text{C} \leq T_A \leq +70^\circ\text{C}$ $-40^\circ\text{C} \leq T_A \leq +85^\circ\text{C}$		1.1	1.3	V
	Emitter Follower Configuration (Figure 4)	$V_C = 15\text{V}$, $I_E = 200\text{mA}$			1.5	2.5	
$I_{C(off)}$	Collector Off-State Current	$V_{CC} = 40\text{V}$, $V_{CE} = 40\text{V}$		2.0	100	μA	
$I_{E(off)}$	Emitter Off-State Current	$V_{CC} = V_C = 40\text{V}$, $V_E = 0$	$0^\circ\text{C} \leq T_A \leq +70^\circ\text{C}$, $-40^\circ\text{C} \leq T_A \leq +85^\circ\text{C}$		-100	μA	
OUTPUT CONTROL (Figure 6)							
V_{OCL}	Output Control Voltage Required for Single Ended or Parallel Output Operation				0.4	V	
V_{OCH}	Output Control Voltage Required for Push-Pull Operation		2.4			V	
TOTAL DEVICE							
I_{CC}	Standby Power Supply Current			6.0	10	mA	
OUTPUT AC CHARACTERISTICS Use Recommended Operating Conditions with $T_A = 25^\circ\text{C}$							
t_r	Rise Time of Output Voltage Common Emitter Configuration (Figure 3)			100	200	ns	
	Emitter Follower Configuration (Figure 4)			100	200		
t_f	Fall Time of Output Voltage Common Emitter Configuration (Figure 3)			25	100	ns	
	Emitter Follower Configuration (Figure 4)			40	100		

Note 1: $T_{J\text{Max}} = 150^\circ\text{C}$ for the Molded DIP, and 175°C for the Ceramic DIP.

Note 2: Ratings apply to ambient temperature at 25°C . Above this temperature, derate the 16L-Ceramic DIP at $10\text{mW}/^\circ\text{C}$, and the 16L-Molded DIP at $8.3\text{mW}/^\circ\text{C}$.

Note 3: Selected devices with tightened tolerance reference voltage available.

Note 4: These limits apply when the voltage measured at Lead 3 is within the range specified.

Functional Description

The basic oscillator (switching) frequency is controlled by an external resistor (R_T) and capacitor (C_T). The relationship between the values of R_T , C_T and frequency is shown in Figure 10.

The level of the sawtooth wave form is compared with an error voltage by the pulse width modulated comparator. The output of the PWM Comparator directs the pulse steering flip-flop and the output control logic.

The error voltage is generated by the error amplifier. The error amplifier boosts the voltage difference between the output and the 5.0V internal reference. See Figure 7 for error amp sensing techniques. The second error amp is typically used to implement current-limiting.

The output control logic selects either push-pull or single-ended operation of the output transistors (see Figure 6).

The dead time control prevents on-state overlap of the output transistors as can be seen in Figure 5. The dead time is approximately 3.0% or 5.0% of the total period if the dead time control is grounded. This dead time can be increased by connecting the dead time control to a voltage up to 5.0V.

The frequency response of the error amps (Figure 11) can be modified by using external resistors and capacitors. These components are typically connected between the compensation terminal and the inverting input of the error amps.

The switching frequency of two or more LM494 circuits can be synchronized. The timing capacitor, C_T , is connected as shown in Figure 8. Charging current is provided by the master circuit. Discharging is through all the circuits slaved to the master. R_T is required only for the master circuit.

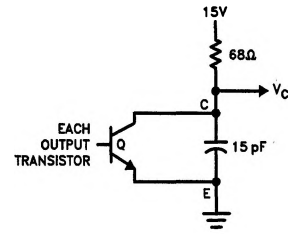

TL/H/10056-5

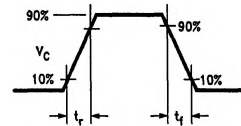

TL/H/10056-6

FIGURE 3. Common Emitter Configuration Test Circuit and Waveform

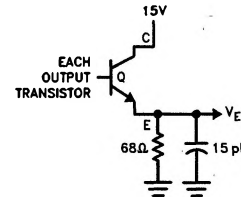

TL/H/10056-7

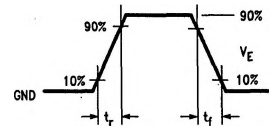

TL/H/10056-8

FIGURE 4. Emitter Follower Configuration Test Circuit and Waveform

Test Circuits

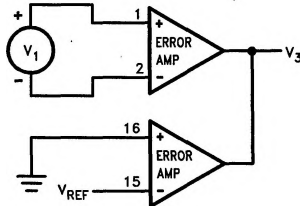

TL/H/10056-3

FIGURE 1. Error Amplifier Test Circuit

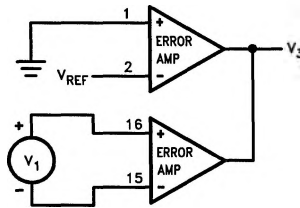

TL/H/10056-4

FIGURE 2. Current Limit Sense Amplifier Test Circuit

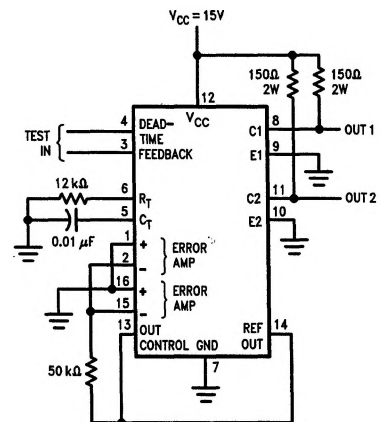

TL/H/10056-9

FIGURE 5. Dead Time and Feedback Control Test Circuit

Typical Applications

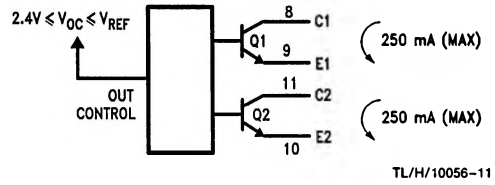
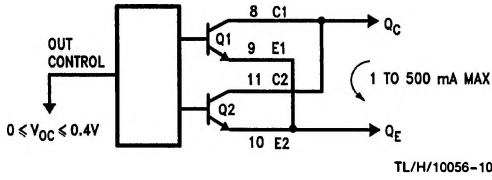

FIGURE 6. Output Connections for Single Ended and Push-Pull Configurations

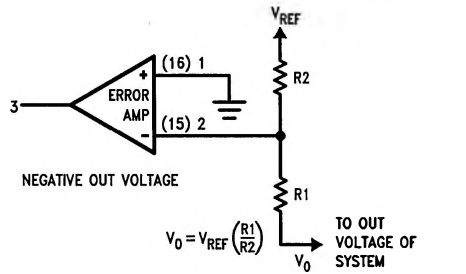
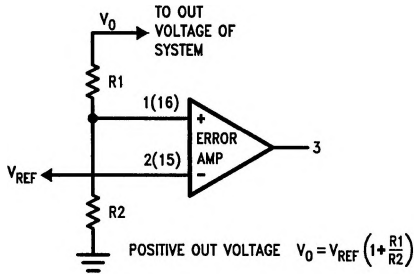

FIGURE 7. Error Amplifier Sensing Techniques

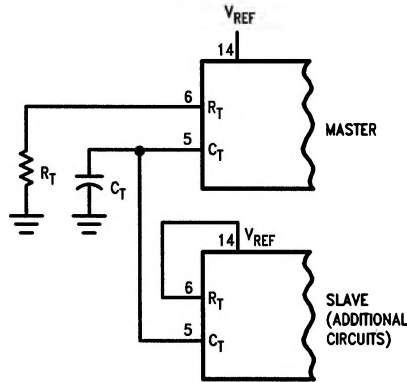

FIGURE 8. Slaving Two or More Control Circuits

Typical Applications (Continued)

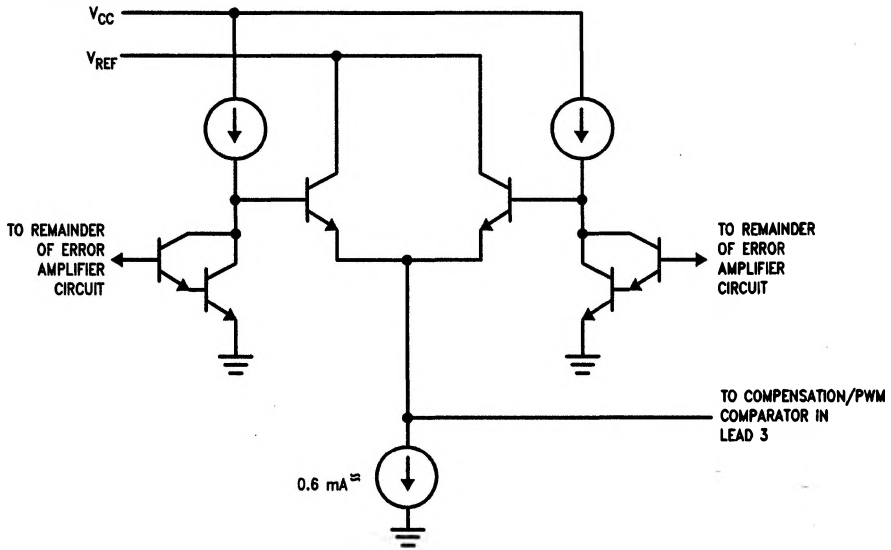
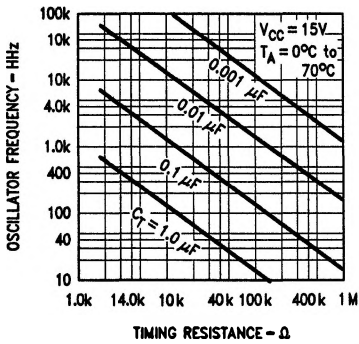

FIGURE 9. Error Amplifier and Current Limit Sense Amplifier Output Circuits

TL/H/10056-16

Typical Performance Characteristics



TL/H/10056-16

FIGURE 10. Oscillator Frequency vs Timing Resistance

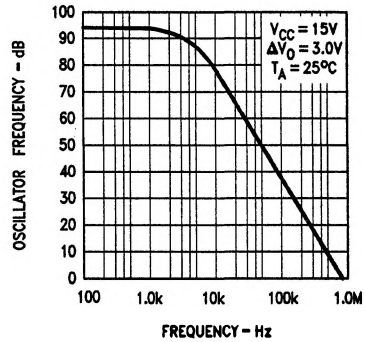

TL/H/10056-17

FIGURE 11. Amplifier Voltage Gain vs Frequency

Voltage Waveforms

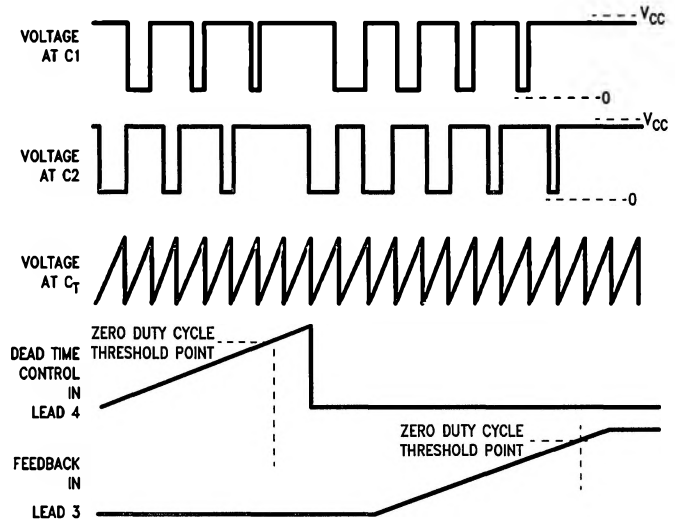

TL/H/10056-18