

LM48100Q Boomer™ Mono, 1.3W Audio Power Amplifier with Output Fault Detection and Volume Control

Check for Samples: [LM48100Q](#)

FEATURES

- Output Fault Detection
- I²C Volume and Mode Control
- Input Mixer/Multiplexer
- High PSRR
- Individual 32-Step Volume Control
- Short Circuit and Thermal Protection
- Advanced Click-and-Pop Suppression
- Low Power Shutdown Mode
- Available in 14-pin HTSSOP Package

APPLICATIONS

- Automotive Instrument Clusters
- Hands-free Car Kits
- Medical

KEY SPECIFICATIONS

- Output Power at $V_{DD} = 5V$, $R_L = 8\Omega$, $THD+N \leq 1\%$ 1.3W (typ)
- Quiescent Power Supply Current at 5V 6mA (Typ)
- PSRR at 1kHz 74dB (Typ)
- Shutdown current 0.01 μ A (Typ)

DESCRIPTION

The LM48100Q is a single supply, mono, bridge-tied load amplifier with I²C volume control, ideal for automotive applications. A comprehensive output fault detection system senses the load conditions, protecting the device during short circuit events, as well as detecting open circuit conditions.

Operating from a single 5V supply, the LM48100Q delivers 1.3W of continuous output power to an 8 Ω load with < 1% THD+N. Flexible power supply requirements allow operation from 3.0V to 5.5V. High power supply rejection ratio (PSRR), 74dB at 1kHz, allows the device to operate in noisy environments without additional power supply conditioning.

The LM48100Q features dual audio inputs that can be mixed/multiplexed to the device output. Each input path has its own independent, 32-step volume control. The mixer, volume control and device mode select are controlled through an I²C compatible interface. An open drain \overline{FAULT} output indicates when a fault has occurred. Comprehensive output short circuit and thermal overload protection prevent the device from being damaged during a fault condition.

A low power shutdown mode reduces supply current consumption to 0.01 μ A. Superior click and pop suppression eliminates audible transients on power-up/down and during shutdown. The LM48100Q is available in an 14-pin HTSSOP package



Please be aware that an important notice concerning availability, standard warranty, and use in critical applications of Texas Instruments semiconductor products and disclaimers thereto appears at the end of this data sheet.

Boomer is a trademark of Texas Instruments.

All other trademarks are the property of their respective owners.

Typical Application

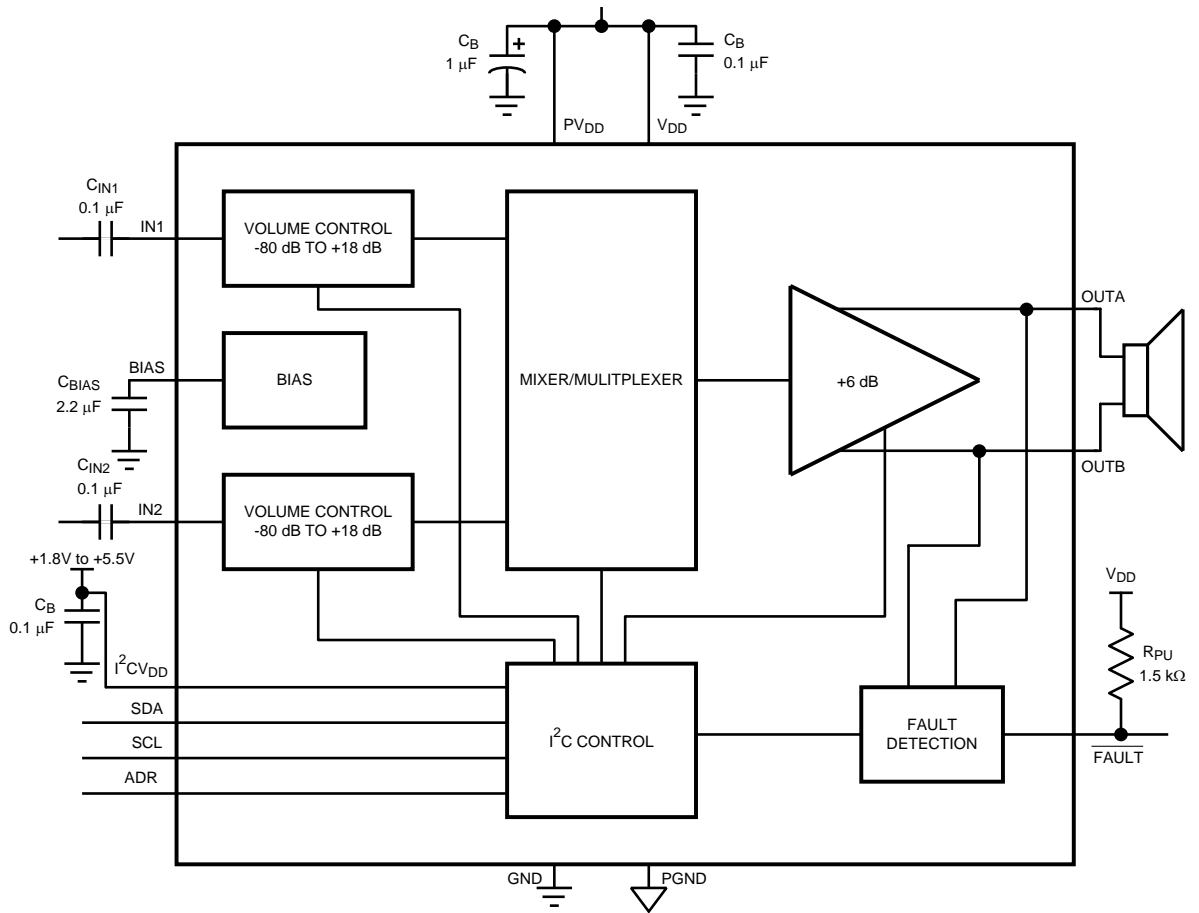

Figure 1. Typical Audio Amplifier Application Circuit

Connection Diagram

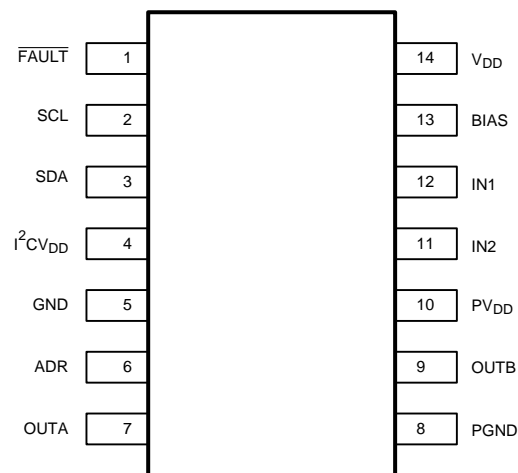

Figure 2. HTSSOP Package Top View
See Package Number PWP0014A

BUMP DESCRIPTIONS

Pin	Pin Name	Description
1	$\overline{\text{FAULT}}$	Open-Drain output fault flag. $\overline{\text{FAULT}} = 0$ indicates that a fault condition has occurred.
2	SCL	I ² C Clock Input
3	SDA	I ² C Serial Data Input
4	I ² CV _{DD}	I ² C Interface Power Supply
5	GND	Ground
6	ADR	I ² C Address Bit. Connect to I ² CV _{DD} to set address bit, B1 = 1. Connect to GND to set address bit B1 = 0
7	OUTA	Non-Inverting Audio Output
8	PGND	Power Ground
9	OUTB	Inverting Audio Output
10	PV _{DD}	Output Amplifier Power Supply
11	IN2	Audio Input 2
12	IN1	Audio Input 1
13	BIAS	Bias Bypass
14	V _{DD}	Power Supply
—	Exposed Pad	Exposed paddle. Connect to GND.



These devices have limited built-in ESD protection. The leads should be shorted together or the device placed in conductive foam during storage or handling to prevent electrostatic damage to the MOS gates.

Absolute Maximum Ratings ⁽¹⁾⁽²⁾⁽³⁾

Supply Voltage, continuous ⁽¹⁾	6V	
Storage Temperature	–65°C to +150°C	
Input Voltage	–0.3V to V _{DD} + 0.3V	
Power Dissipation ⁽⁴⁾	Internally Limited	
ESD Rating ⁽⁵⁾	2500V	
ESD Rating ⁽⁶⁾	300V	
Junction Temperature	150°C	
Thermal Resistance	θ_{JA} ⁽⁷⁾	37.8°C/W
	θ_{JC}	5.2°C/W
Lead Temperature (Soldering 4 sec)	260°C	

For detailed information on soldering plastic HTSSOP and LLP packages, refer to the Packaging Data Book available from Texas Instruments.

- (1) “*Absolute Maximum Ratings*” indicate limits beyond which damage to the device may occur, including inoperability and degradation of device reliability and/or performance. Functional operation of the device and/or non-degradation at the *Absolute Maximum Ratings* or other conditions beyond those indicated in the *Recommended Operating Conditions* is not implied. The *Recommended Operating Conditions* indicate conditions at which the device is functional and the device should not be operated beyond such conditions. All voltages are measured with respect to the ground pin, unless otherwise specified.
- (2) The *Electrical Characteristics* tables list guaranteed specifications under the listed *Recommended Operating Conditions* except as otherwise modified or specified by the *Electrical Characteristics Conditions* and/or Notes. Typical specifications are estimations only and are not guaranteed.
- (3) If Military/Aerospace specified devices are required, please contact the Texas Instruments Sales Office/Distributors for availability and specifications.
- (4) θ_{JA} measured with a 4 layer JEDEC board.
- (5) Human body model, applicable std. JESD22-A114C.
- (6) Machine model, applicable std. JESD22-A115-A.
- (7) The maximum power dissipation must be derated at elevated temperatures and is dictated by T_{JMAX}, θ_{JA} , and the ambient temperature, T_A. The maximum allowable power dissipation is P_{DMAX} = (T_{JMAX} - T_A) / θ_{JA} or the number given in *Absolute Maximum Ratings*, whichever is lower.

Operating Ratings⁽¹⁾⁽²⁾

Temperature Range	$T_{MIN} \leq T_A \leq T_{MAX}$	$-40^{\circ}\text{C} \leq T_A \leq +105^{\circ}\text{C}$
Supply Voltage	V_{DD} and PV_{DD}	$3.0\text{V} \leq V_{DD} \leq 5.5\text{V}$
I ² C Supply Voltage	I ² CV _{DD}	$1.8\text{V} \leq I^2CV_{DD} \leq 5.5\text{V}$
		$I^2CV_{DD} \leq V_{DD}$

- (1) “*Absolute Maximum Ratings*” indicate limits beyond which damage to the device may occur, including inoperability and degradation of device reliability and/or performance. Functional operation of the device and/or non-degradation at the *Absolute Maximum Ratings* or other conditions beyond those indicated in the *Recommended Operating Conditions* is not implied. The *Recommended Operating Conditions* indicate conditions at which the device is functional and the device should not be operated beyond such conditions. All voltages are measured with respect to the ground pin, unless otherwise specified.
- (2) The *Electrical Characteristics* tables list guaranteed specifications under the listed *Recommended Operating Conditions* except as otherwise modified or specified by the *Electrical Characteristics Conditions* and/or Notes. Typical specifications are estimations only and are not guaranteed.

Audio Amplifier Electrical Characteristics $V_{DD} = 5.0\text{V}$ ⁽¹⁾⁽²⁾

The following specifications apply for Programmable Gain = 0dB, $R_L = 8\Omega$, $f = 1\text{kHz}$, unless otherwise specified. Limits apply for $T_A = 25^{\circ}\text{C}$.

Symbol	Parameter	Conditions	LM48100Q			Units (Limits)
			Typical ⁽³⁾	Room Temp Limits ⁽⁴⁾	Extended Temp Limits ^{(4) (5)}	
I_{DD}	Quiescent Power Supply Current	$V_{IN} = 0\text{V}$, Both channels active $R_L = 8\Omega$ $R_L = \infty$	4.4 4.2	9 6	10.8 7.9	mA (max) mA (max)
I_{DD}	Diagnostic Mode Quiescent Power Supply Current	Diagnostic Mode Enabled, $R_L = \infty$	12.5	14.5		mA (max)
I_{SD}	Shutdown Current	Shutdown Enabled	0.01	1		μA (max)
V_{OS}	Differential Output Offset Voltage	$V_{IN} = 0\text{V}$, $R_L = 8\Omega$	8.8	50	75	mV (max)
T_{WU}	Wake-Up Time	Time from shutdown to audio available	11.6	50		ms (max)
A_V	Gain	Minimum Gain Setting	-54	± 1.0	± 2.0	dB (max) dB (min)
		Maximum Gain Setting	18	± 1.0	± 1.0	dB (max) dB (min)
Mute	Mute Attenuation		-80	-77	-74	dB (max)
R_{IN}	Input Resistance	$A_V = 18\text{dB}$	12.5	11.5 13.5		k Ω (min) k Ω (max)
		$A_V = -54\text{dB}$	110	98 120	89 130	k Ω (min) k Ω (max)
P_O	Output Power	$R_L = 8\Omega$, $f = 1\text{kHz}$ THD+N = 10% THD+N = 1%	1.6 1.3	1.05	0.96	W W (min)
THD+N	Total Harmonic Distortion + Noise	$P_O = 850\text{mW}$, $f = 1\text{kHz}$, $R_L = 8\Omega$	0.04			%
PSRR	Power Supply Rejection Ratio	$V_{RIPPLE} = 200\text{mV}_{P-P}$ Sine, Inputs AC GND, $C_{IN-} = 1\mu\text{F}$, input referred, $C_{BIAS} = 2.2\mu\text{F}$				
		$f = 217\text{Hz}$	79	66	63	dB (min)
		$f = 1\text{kHz}$	74			dB

- (1) “*Absolute Maximum Ratings*” indicate limits beyond which damage to the device may occur, including inoperability and degradation of device reliability and/or performance. Functional operation of the device and/or non-degradation at the *Absolute Maximum Ratings* or other conditions beyond those indicated in the *Recommended Operating Conditions* is not implied. The *Recommended Operating Conditions* indicate conditions at which the device is functional and the device should not be operated beyond such conditions. All voltages are measured with respect to the ground pin, unless otherwise specified.
- (2) The *Electrical Characteristics* tables list guaranteed specifications under the listed *Recommended Operating Conditions* except as otherwise modified or specified by the *Electrical Characteristics Conditions* and/or Notes. Typical specifications are estimations only and are not guaranteed.
- (3) Typical values represent most likely parametric norms at $T_A = +25^{\circ}\text{C}$, and at the *Recommended Operation Conditions* at the time of product characterization and are not guaranteed.
- (4) Datasheet min/max specification limits are guaranteed by test or statistical analysis.
- (5) Min/max specification limits guaranteed for $T_A = -40^{\circ}\text{C}$ to 105°C .

Audio Amplifier Electrical Characteristics $V_{DD} = 5.0V^{(1)(2)}$ (continued)

The following specifications apply for Programmable Gain = 0dB, $R_L = 8\Omega$, $f = 1\text{kHz}$, unless otherwise specified. Limits apply for $T_A = 25^\circ\text{C}$.

Symbol	Parameter	Conditions	LM48100Q			Units (Limits)
			Typical ⁽³⁾	Room Temp Limits ⁽⁴⁾	Extended Temp Limits ^{(4) (5)}	
SNR	Signal-to-Noise-Ratio	$P_{OUT} = \text{TBDmW}$, $f = 1\text{kHz}$	104			dB
ϵ_{OS}	Output Noise	$A_V = 0\text{dB}$, A-weighted Filter	12			μV
$I_{OUT(\text{FAULT})}$	$\overline{\text{FAULT}}$ Output Current	$\overline{\text{FAULT}} = 0$, $V_{OUT(\text{FAULT})} = 0.4\text{V}$	3			mA
R_{FAULT}	Output to Supply Short Circuit Detection Threshold	Short between either OUTA to V_{DD} or GND, or OUTB to V_{DD} or GND Short Circuit Open Circuit		3 7.5	3 7.5	k Ω (min) k Ω (max)
R_{FAULT}	Output to Supply Short Circuit Detection Threshold	Short between both OUTA and OUTB to V_{DD} or GND Short Circuit Open Circuit		6 15		k Ω (min) k Ω (max)
R_{OPEN}	Open Circuit Detection Threshold	Open circuit between OUTA and OUTB		100 200		Ω (min) Ω (max)
R_{SHT}	Output to Output Short Circuit Detection Threshold	Short circuit between OUTA and OUTB		2 6		Ω (min) Ω (max)
I_{SHTCKT}	Short Circuit Current Limit		1.47	1.67	2	A (max)
T_{SD}	Thermal Shutdown Threshold		170			$^\circ\text{C}$
t_{DIAG}	Diagnostic Time		58			ms

Audio Amplifier Electrical Characteristics $V_{DD} = 3.6V^{(1)(2)}$

The following specifications apply for Programmable Gain = 0dB, $R_L = 8\Omega$, $f = 1\text{kHz}$, unless otherwise specified. Limits apply for $T_A = 25^\circ\text{C}$.

Symbol	Parameter	Conditions	LM48100Q			Units (Limits)
			Typical ⁽³⁾	Room Temp Limits ⁽⁴⁾	Extended Temp Limits ^{(4) (5)}	
I_{DD}	Quiescent Power Supply Current	$V_{IN} = 0\text{V}$, Both channels active $R_L = 8\Omega$ $R_L = \infty$	3.8 3.6	8.5 5	10.8 7	mA (max) mA (max)
I_{DD}	Diagnostic Mode Quiescent Power Supply Current	Diagnostic Mode Enabled	11.7	14.5		mA (max)
I_{SD}	Shutdown Current	Shutdown Enabled	0.01	1		μA (max)
V_{OS}	Differential Output Offset Voltage	$V_{IN} = 0\text{V}$, $R_L = 8\Omega$	8.8	50	76	mV (max)
T_{WU}	Wake-Up Time	Time from shutdown to audio available	11.5	50		ms (max)

- (1) "Absolute Maximum Ratings" indicate limits beyond which damage to the device may occur, including inoperability and degradation of device reliability and/or performance. Functional operation of the device and/or non-degradation at the Absolute Maximum Ratings or other conditions beyond those indicated in the Recommended Operating Conditions is not implied. The Recommended Operating Conditions indicate conditions at which the device is functional and the device should not be operated beyond such conditions. All voltages are measured with respect to the ground pin, unless otherwise specified.
- (2) The Electrical Characteristics tables list guaranteed specifications under the listed Recommended Operating Conditions except as otherwise modified or specified by the Electrical Characteristics Conditions and/or Notes. Typical specifications are estimations only and are not guaranteed.
- (3) Typical values represent most likely parametric norms at $T_A = +25^\circ\text{C}$, and at the Recommended Operation Conditions at the time of product characterization and are not guaranteed.
- (4) Datasheet min/max specification limits are guaranteed by test or statistical analysis.
- (5) Min/max specification limits guaranteed for $T_A = -40^\circ\text{C}$ to 105°C .

Audio Amplifier Electrical Characteristics $V_{DD} = 3.6V^{(1)(2)}$ (continued)

The following specifications apply for Programmable Gain = 0dB, $R_L = 8\Omega$, $f = 1\text{kHz}$, unless otherwise specified. Limits apply for $T_A = 25^\circ\text{C}$.

Symbol	Parameter	Conditions	LM48100Q			Units (Limits)
			Typical ⁽³⁾	Room Temp Limits ⁽⁴⁾	Extended Temp Limits ^{(4) (5)}	
A_V	Gain	Minimum Gain Setting	-54	± 1		dB (max) dB (min)
		Maximum Gain Setting	18	± 1		dB (max) dB (min)
Mute	Mute Attenuation		-79	-77		dB (max)
R_{IN}	Input Resistance	$A_V = 18\text{dB}$	12.5	11.5 13.5		k Ω (min) k Ω (max)
		$A_V = -54\text{dB}$	110	98 120	89 135	k Ω (min) k Ω (max)
P_O	Output Power	$R_L = 8\Omega$, $f = 1\text{kHz}$ THD+N = 10% THD+N = 1%	820 660	480		mW mW (min)
THD+N	Total Harmonic Distortion + Noise	$P_O = 400\text{mW}$, $f = 1\text{kHz}$, $R_L = 8\Omega$	0.04			% (max)
PSRR	Power Supply Rejection Ratio	$V_{RIPPLE} = 200\text{mV}_{P-P}$ Sine, Inputs AC GND, $C_{IN} = 1\mu\text{F}$, input referred, $C_{BIAS} = 2.2\mu\text{F}$				
		$f = 217\text{Hz}$ $f = 1\text{kHz}$	78 75	66	60	dB (min) dB
SNR	Signal-to-Noise-Ratio	$P_{OUT} = \text{TBDmW}$, $f = 1\text{kHz}$	106			dB
ϵ_{OS}	Output Noise	$A_V = 0\text{dB}$, A-weighted Filter	12.5			μV
$I_{OUT(\overline{FAULT})}$	\overline{FAULT} Output Current	$\overline{FAULT} = 0$, $V_{OUT(\overline{FAULT})} = 0.4\text{V}$	3			mA
R_{FAULT}	Output to Supply Short Circuit Detection Threshold	Short between either OUTA to V_{DD} or GND, or OUTB to V_{DD} or GND Short Circuit Open Circuit		3 7.5		k Ω (min) k Ω (max)
R_{FAULT}	Output to Supply Short Circuit Detection Threshold	Short between both OUTA and OUTB to V_{DD} or GND Short Circuit Open Circuit		6 15		k Ω (min) k Ω (max)
R_{OPEN}	Open Circuit Detection Threshold	Open circuit between OUTA and OUTB		100 200		Ω (min) Ω (max)
R_{SHT}	Output to Output Short Circuit Detection Threshold	Short circuit between OUTA and OUTB		2 6		Ω (min) Ω (max)
I_{SHTCKT}	Short Circuit Current Limit		1.43			A
T_{SD}			170			$^\circ\text{C}$
t_{DIAG}	Diagnostic Time		63			ms

I²C Interface Characteristics $V_{DD} = 5V, 2.2V \leq I^2CV_{DD} \leq 5.5V$ ⁽¹⁾⁽²⁾

The following specifications apply for $A_V = 0dB, R_L = 8\Omega, f = 1kHz$, unless otherwise specified. Limits apply for $T_A = 25^\circ C$.

Symbol	Parameter	Conditions	LM48100Q		Units (Limits)
			Typical ⁽³⁾	Limits ⁽⁴⁾	
t ₁	SCL period			2.5	μs (min)
t ₂	SDA Setup Time			100	ns (min)
t ₃	SDA Stable Time			0	ns (min)
t ₄	Start Condition Time			100	ns (min)
t ₅	Stop Condition Time			100	ns (min)
t ₆	SDA Data Hold Time			100	ns (min)
V _{IH}	Logic High Input Threshold			0.7 x I ² CV _{DD}	V (min)
V _{IL}	Logic Low Input Threshold			0.3 x I ² CV _{DD}	V (max)

- (1) “*Absolute Maximum Ratings*” indicate limits beyond which damage to the device may occur, including inoperability and degradation of device reliability and/or performance. Functional operation of the device and/or non-degradation at the *Absolute Maximum Ratings* or other conditions beyond those indicated in the *Recommended Operating Conditions* is not implied. The *Recommended Operating Conditions* indicate conditions at which the device is functional and the device should not be operated beyond such conditions. All voltages are measured with respect to the ground pin, unless otherwise specified.
- (2) The *Electrical Characteristics* tables list guaranteed specifications under the listed *Recommended Operating Conditions* except as otherwise modified or specified by the *Electrical Characteristics Conditions* and/or Notes. Typical specifications are estimations only and are not guaranteed.
- (3) Typical values represent most likely parametric norms at $T_A = +25^\circ C$, and at the *Recommended Operation Conditions* at the time of product characterization and are not guaranteed.
- (4) Datasheet min/max specification limits are guaranteed by test or statistical analysis.

I²C Interface Characteristics $V_{DD} = 5V, 1.8V \leq I^2CV_{DD} \leq 2.2V$ ⁽¹⁾⁽²⁾

The following specifications apply for $A_V = 0dB, R_L = 8\Omega, f = 1kHz$, unless otherwise specified. Limits apply for $T_A = 25^\circ C$.

Symbol	Parameter	Conditions	LM48100Q		Units (Limits)
			Typical ⁽³⁾	Limits ⁽⁴⁾	
t ₁	SCL period			2.5	μs (min)
t ₂	SDA Setup Time			250	ns (min)
t ₃	SDA Stable Time			0	ns (min)
t ₄	Start Condition Time			250	ns (min)
t ₅	Stop Condition Time			250	ns (min)
t ₆	SDA Data Hold Time			250	ns (min)
V _{IH}	Logic High Input Threshold			0.7 x I ² CV _{DD}	V (min)
V _{IL}	Logic Low Input Threshold			0.3 x I ² CV _{DD}	V (max)

- (1) “*Absolute Maximum Ratings*” indicate limits beyond which damage to the device may occur, including inoperability and degradation of device reliability and/or performance. Functional operation of the device and/or non-degradation at the *Absolute Maximum Ratings* or other conditions beyond those indicated in the *Recommended Operating Conditions* is not implied. The *Recommended Operating Conditions* indicate conditions at which the device is functional and the device should not be operated beyond such conditions. All voltages are measured with respect to the ground pin, unless otherwise specified.
- (2) The *Electrical Characteristics* tables list guaranteed specifications under the listed *Recommended Operating Conditions* except as otherwise modified or specified by the *Electrical Characteristics Conditions* and/or Notes. Typical specifications are estimations only and are not guaranteed.
- (3) Typical values represent most likely parametric norms at $T_A = +25^\circ C$, and at the *Recommended Operation Conditions* at the time of product characterization and are not guaranteed.
- (4) Datasheet min/max specification limits are guaranteed by test or statistical analysis.

Typical Performance Characteristics

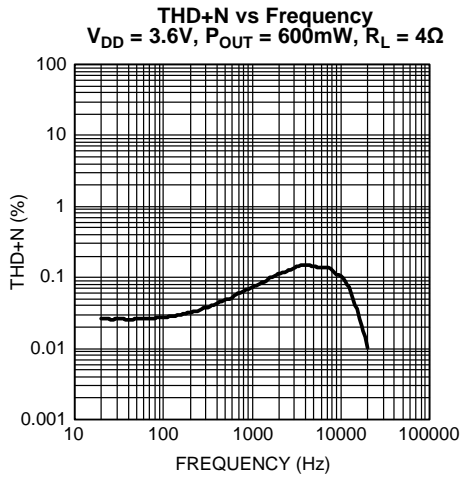

Figure 3.

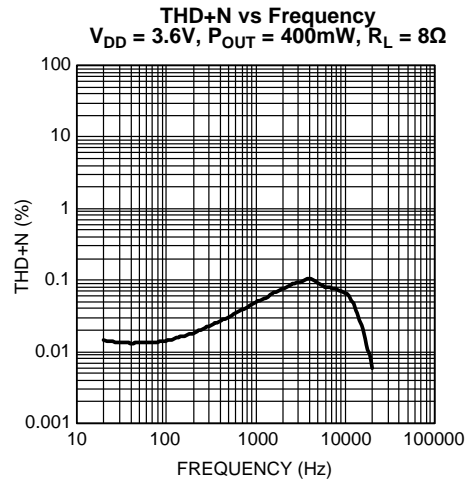

Figure 4.

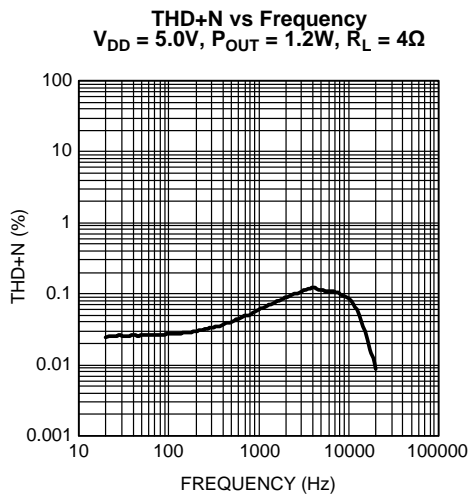

Figure 5.

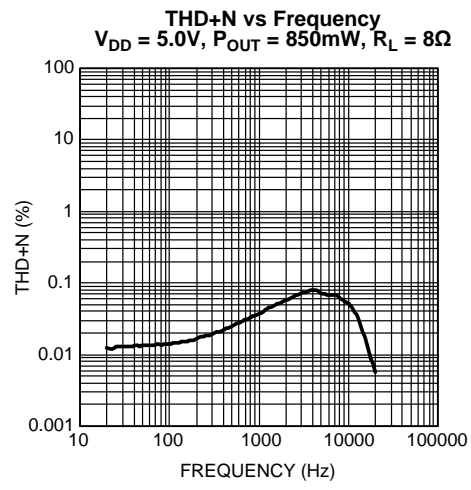

Figure 6.

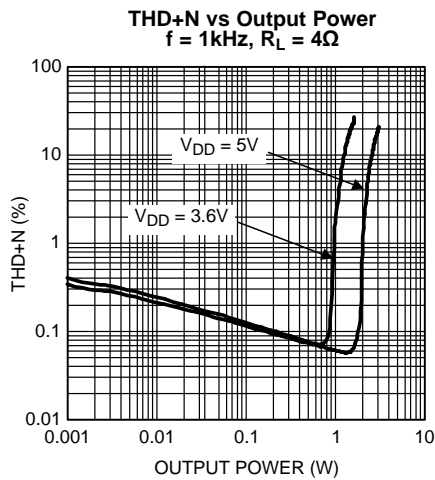

Figure 7.

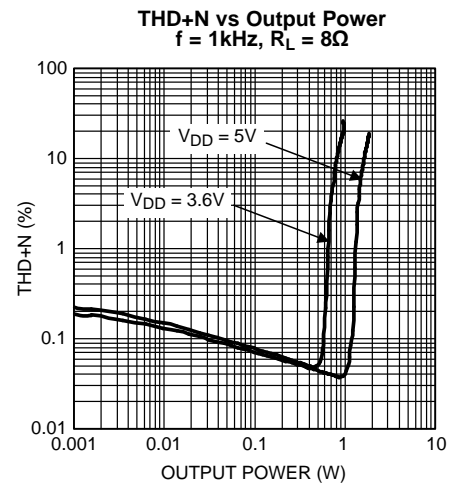

Figure 8.

Typical Performance Characteristics (continued)

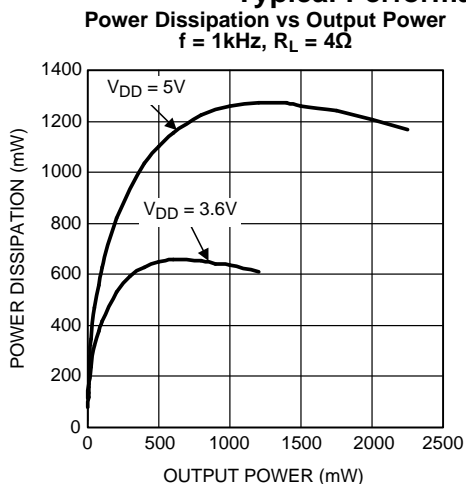

Figure 9.

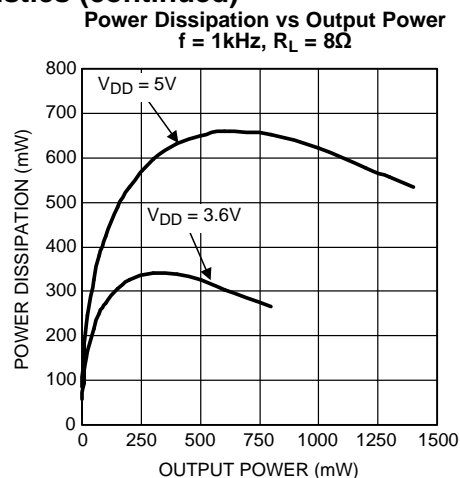

Figure 10.

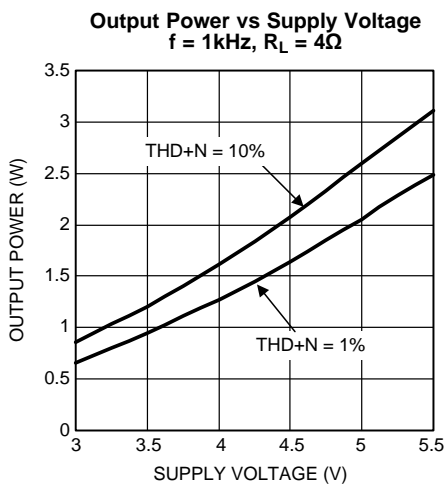

Figure 11.

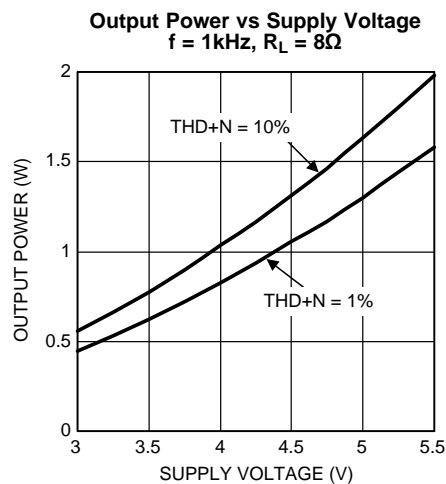

Figure 12.

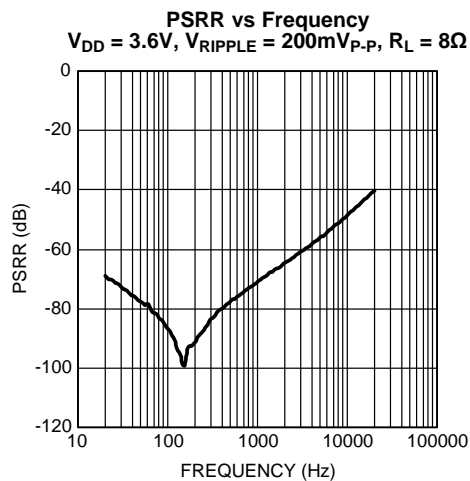

Figure 13.

APPLICATION INFORMATION

WRITE-ONLY I²C COMPATIBLE INTERFACE

The LM48100Q is controlled through an I²C compatible serial interface that consists of a serial data line (SDA) and a serial clock (SCL). The clock line is uni-directional. The data line is bi-directional (open drain). The LM48100Q and the master can communicate at clock rates up to 400kHz. Figure 14 shows the I²C interface timing diagram. Data on the SDA line must be stable during the HIGH period of SCL. The LM48100Q is a transmit/receive slave-only device, reliant upon the master to generate the SCL signal. Each transmission sequence is framed by a START condition and a STOP condition (Figure 15). Each data word, device address and data, transmitted over the bus is 8 bits long and is always followed by an acknowledge pulse (Figure 16). The LM48100Q device address is 111110X, where X is determined by ADR (Table 2). ADR = 1 sets the device address to 1111101. ADR = 0 sets the device address to 1111100.

I²C BUS FORMAT

The I²C bus format is shown in Figure 16. The START signal, the transition of SDA from HIGH to LOW while SCL is HIGH, is generated, alerting all devices on the bus that a device address is being written to the bus.

The 7-bit device address is written to the bus, most significant bit (MSB) first, followed by the R/W bit. R/W = 0 indicates the master is writing to the slave device, R/W = 1 indicates the master wants to read data from the slave device. Set R/W = 0; the LM48100Q is a WRITE-ONLY device and will not respond the R/W = 1. The data is latched in on the rising edge of the clock. Each address bit must be stable while SCL is HIGH. After the last address bit is transmitted, the master device releases SDA, during which time, an acknowledge clock pulse is generated by the slave device. If the LM48100Q receives the correct address, the device pulls the SDA line low, generating an acknowledge bit (ACK).

Once the master device registers the ACK bit, the 8-bit register data word is sent. Each data bit should be stable while SCL is HIGH. After the 8-bit register data word is sent, the LM48100Q sends another ACK bit. Following the acknowledgement of the register data word, the master issues a STOP bit, allowing SDA to go high.

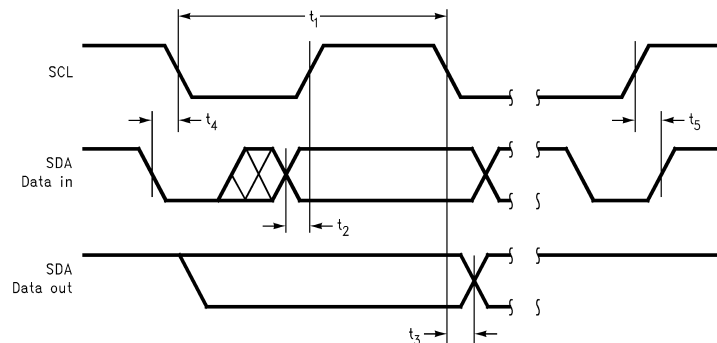

Figure 14. I²C Timing Diagram

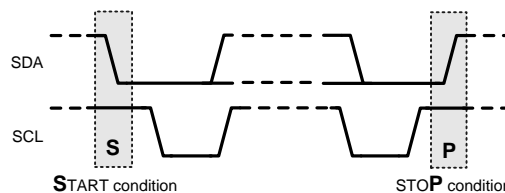

Figure 15. Start and Stop Diagram

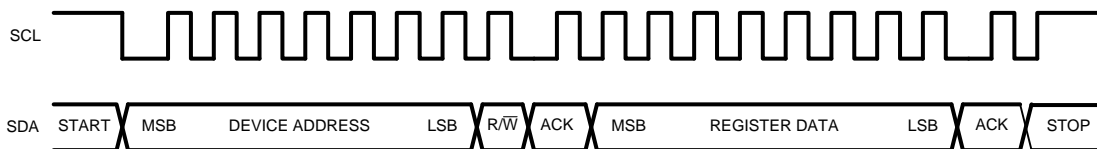

Figure 16. Example Write Sequence

Table 1. Device Address

	B7	B6	B5	B4	B3	B2	B1	B0 R/W
ADR = 0	1	1	1	1	1	0	0	0
ADR = 1	1	1	1	1	1	0	1	0

Table 2. I²C Control Registers

Register Address	Register Name	B7	B6	B5	B4	B3	B2	B1	B0
0	MODE CONTROL	0	0	0	POWER_ON	INPUT_2	INPUT_1	0	0
1	DIAGNOSTIC CONTROL	0	0	1	DG_EN	DG_CONT	DG_RESET	ILIMIT	0
2	FAULT DETECTION CONTROL	0	1	0	TSD	OCF	RAIL_SHT	OUTPUT_OPEN	OUTPUT_SHORT
3	VOLUME CONTROL 1	0	1	1	VOL1_4	VOL1_3	VOL1_2	VOL1_1	VOL1_0
4	VOLUME CONTROL 2	1	0	0	VOL2_4	VOL2_3	VOL2_2	VOL_2	VOL2_0

Table 3. Mode Control Registers

BIT	NAME	VALUE	DESCRIPTION
B0, B1	RESERVED	0	Unused
B2	INPUT_1	0	IN1 Input unselected
		1	IN1 Input selected
B3	INPUT_2	0	IN2 Input unselected
		1	IN2 Input selected
B4	POWER_ON	0	Device Disabled
		1	Device Enabled

DIAGNOSTIC CONTROL

The LM48100Q output fault diagnostics are controlled through the I²C interface. When power is initially applied to the device, the LM48100Q initializes, performing the full diagnostic sequence; output short to V_{DD} and GND, outputs shorted together, and no load condition, is performed. The device remains in shutdown while the initial diagnostic check is performed. Any I²C commands written to the device during this time are stored and implemented once the diagnostic check is complete. The initial diagnostic sequence can be terminated by setting DG_RESET = 1.

The Diagnostic Control register, register 1, controls the LM48100Q diagnostic process. Bit B4, DG_EN, enables the output fault detection. Set DG_EN = 1 to enable the output diagnostic test sequence. The LM48100Q treats the DG_EN bit as rising-edge-sensitive; once DG_EN = 1 is clocked into the device, the diagnostic test is performed. If the LM48100Q is in one-shot mode, once the test sequence is performed, the DG_EN bit is ignored and the test sequence will not be run again. Cycle DG_EN from high-to-low-to-high to re-enable the one-shot diagnostic test sequence.

In continuous diagnostic mode, the test sequence is repeated until either a fault condition occurs, DG_RESET is cycled, or the device is taken out of continuous diagnostic mode. Set DG_CONT = 1 before setting DG_EN = 1 to initiate a continuous diagnostic. Set DG-CONT = 0 to disable continuous diagnostic mode. When the device is active and DG_EN = 0, the LM48100Q does not perform the output short, or no load diagnostics, however, the thermal overload and output over current protection circuitry remains active, and disables the device should a thermal or over-current fault occur. The initial diagnostic operation when power is applied to the device occurs regardless of the state of DG_EN. The LM48100Q output fault detection can be set to either continuous mode where the output diagnostic occurs every 60ms, or a one-shot mode. Set bit B3 (DG_CONT) to 1 for continuous mode, set B3 = 0 for one-shot mode.

Bit B2, DG_RESET, restores the LM48100Q to normal operation after an output fault is detected. Toggle DG_RESET to re-enable the device outputs and set FAULT high.

Table 4. Diagnostic Control Register

BIT	NAME	VALUE	DESCRIPTION
B0	RESERVED	0	Unused
B1	ILIMIT	0	Fixed output current limit
		1	Supply dependent output current limit
B2	DG_RESET	0	Normal operation. $\overline{\text{FAULT}}$ remains low and device is disabled once a fault occurs.
		1	Reset $\overline{\text{FAULT}}$ output. Device returns to pre-fault operation.
B3	DG_CONT	0	One shot diagnostic
		1	Continuous diagnostic
B4	DG_EN	0	Disable diagnostic
		1	Enable diagnostic

FAULT DETECTION CONTROL REGISTER

The LM48100Q output fault tests are individually controlled through the Fault Detection Control register, register 2. Setting any of the bits in the Fault Detection Control register to 1 causes the $\overline{\text{FAULT}}$ circuitry to ignore the associated test. For example, if B2 (RAIL_SHT) = 1 and the output is shorted to V_{DD} , the $\overline{\text{FAULT}}$ output remains high. Although the $\overline{\text{FAULT}}$ circuitry ignores the selected test, the LM48100Q protection circuitry remains active, and disables the device. This feature is useful for diagnosing which fault caused a $\overline{\text{FAULT}}$ condition.

If DG_EN = 1, and a diagnostic sequence is initiated, all the tests are performed regardless of their state in the Fault Detection Control register. If DG_EN = 0, the RAIL_SHT, OUTPUT_OPEN and OUTPUT_SHT tests are not performed, however, the thermal overload and output over-current detection circuitry remains active.

Table 5. Fault Detection Control Register

BIT	NAME	VALUE	DESCRIPTION
B0	OUTPUT_SHT	0	Normal operation
		1	Ignore output short circuit fault (outputs shorted together)
B1	OUTPUT_OPEN	0	Normal operation
		1	Ignore output short circuit fault
B2	RAIL_SHT	0	Normal operation
		1	Ignore output short to V_{DD} or GND fault
B3	OVF	0	Normal operation
		1	Ignore output over-current fault
B4	TSD	0	Normal operation
		1	Ignore thermal overload fault

GENERAL AMPLIFIER FUNCTION

Bridge Configuration Explained

The LM48100Q is designed to drive a load differentially, a configuration commonly referred to as a bridge-tied load (BTL). The BTL configuration differs from the single-ended configuration, where one side of the load is connected to ground. A BTL amplifier offers advantages over a single-ended device. By driving the load differentially, the output voltage is doubled, compared to a single-ended amplifier under similar conditions. This doubling of the output voltage leads to a quadrupling of the output power. For example, the theoretical maximum output power for a single-ended amplifier driving 8Ω and operating from a 5V supply is 158mW, while the theoretical maximum output power for a BTL amplifier operating under the same conditions is 633mW. Since the amplifier outputs are both biased about $V_{DD}/2$, there is no net DC voltage across the load, eliminating the DC blocking capacitors required by single-ended, single-supply amplifiers.

Input Mixer/Multiplexer

The LM48100Q features an input mixer/multiplexer controlled through the I²C interface. The mixer/multiplexer allows either input, or the combination of both inputs to appear at the device output. Bits B2 (INPUT_1) and B3 (INPUT_2) of the Mode Control Register select the individual input channels. Set INPUT_1 = 1 to select the audio signal on IN1. Set INPUT_2 = 1 to select the audio signal on IN2. Setting both INPUT_1 and INPUT_2 = 1 mixes V_{IN1} and V_{IN2} , and the LM48100Q outputs the result as a mono signal (Table 7).

Table 6. Input Multiplexer Control

INPUT_1	INPUT_2	LM48100Q OUTPUT
0	0	MUTE. No input selected
1	0	IN1 ONLY
0	1	IN2 ONLY
1	1	IN1 + IN2

OUTPUT FAULT DETECTION

Output Short to Supplies (V_{DD} or GND)

With a standard speaker load (6Ω - 100Ω) connected between OUTA and OUTB, the LM48100Q can detect a short between the outputs and either V_{DD} or GND. A short is detected if the impedance between either OUTA or OUTB and V_{DD} or GND is less than 3kΩ. A short is also detected if the impedance between BOTH OUTA and OUTB and either V_{DD} or GND is less than 6kΩ. Under either of these conditions, the amplifier outputs are disabled and $\overline{\text{FAULT}}$ is driven low. No short is detected if the impedance between either output and V_{DD} or GND is greater than 7.5kΩ. Likewise, no short is detected if the impedance between BOTH outputs and V_{DD} or GND is greater than 15kΩ.

Output Short Circuit and Open Circuit Detection

The LM48100Q can detect whether the amplifier outputs have been shorted together or, an output open circuit condition has occurred. An output short circuit is detected if the impedance between OUTA and OUTB is less than 2Ω. An open circuit is detected if the impedance between OUTA and OUTB is greater than 200Ω. Under either of these conditions, the amplifier outputs are disabled and $\overline{\text{FAULT}}$ is driven low. The device remains in normal operation if the impedance between OUTA and OUTB is in the range of 6Ω to 100Ω. The output open circuit test is only performed during the initial diagnostic sequence during power up, or when DG_ENABLE is set to 1.

Output Over-Current Detection

The LM48100Q has two over current detection modes, a fixed current limit, and a supply dependent current limit. Bit B1 (ILIMIT) of the Diagnostic Control Register selects the over-current detection mode. Set ILIMIT = 0 to select a fixed current limit of 1.47A (typ). Set ILIMIT = 1 to select the supply dependent current limit mode. In supply dependent mode, the current limit is determined by Equation 1:

$$I_{\text{SHTKT}} = 0.264 \times V_{DD} \quad (\text{A}) \quad (1)$$

If the output current exceeds the current limit, the device outputs are disabled and $\overline{\text{FAULT}}$ is driven low. The output over-current detection circuitry remains active when the diagnostics have been disabled (DG_EN = 0).

Thermal Overload Detection

The LM48100Q has thermal overload threshold of 170°C (typ). If the die temperature exceeds 170°C, the outputs are disabled and $\overline{\text{FAULT}}$ is driven low. The thermal overload detection circuitry remains active when the diagnostics have been disabled (DG_EN = 0).

OPEN FAULT OUTPUT

The LM48100Q features an open drain, fault indication output, $\overline{\text{FAULT}}$, that asserts when a fault condition is detected by the device. $\overline{\text{FAULT}}$ goes low when either an output short, output open, over current, or thermal overload fault is detected, and the diagnostic test is not ignored, see [FAULT DETECTION CONTROL REGISTER](#) section. $\overline{\text{FAULT}}$ remains low even after the fault condition has been cleared and the diagnostic tests are repeated. Toggle DG_RESET to clear $\overline{\text{FAULT}}$.

Connect a 1.5kΩ or higher pull-up resistor between $\overline{\text{FAULT}}$ and V_{DD}.

VOLUME CONTROL

Table 7. Volume Control

Volume Step	VOL4	VOL3	VOL2	VOL1	VOL0	Gain (dB)
1	0	0	0	0	0	-80
2	0	0	0	0	1	-54
3	0	0	0	1	0	-40.5
4	0	0	0	1	1	-34.5
5	0	0	1	0	0	-30
6	0	0	1	0	1	-27
7	0	0	1	1	0	-24
8	0	0	1	1	1	-21
9	0	1	0	0	0	-18
10	0	1	0	0	1	-15
11	0	1	0	1	0	-13.5
12	0	1	0	1	1	-12
13	0	1	1	0	0	-10.5
14	0	1	1	0	1	-9
15	0	1	1	1	0	-7.5
16	0	1	1	1	1	-6
17	1	0	0	0	0	-4.5
18	1	0	0	0	1	-3
19	1	0	0	1	0	-1.5
20	1	0	0	1	1	0
21	1	0	1	0	0	1.5
22	1	0	1	0	1	3
23	1	0	1	1	0	4.5
24	1	0	1	1	1	6
25	1	1	0	0	0	7.5
26	1	1	0	0	1	9
27	1	1	0	1	0	10.5
28	1	1	0	1	1	12
29	1	1	1	0	0	13.5
30	1	1	1	0	1	15
31	1	1	1	1	0	16.5

Table 7. Volume Control (continued)

Volume Step	VOL4	VOL3	VOL2	VOL1	VOL0	Gain (dB)
32	1	1	1	1	1	18

SHUTDOWN FUNCTION

The LM48100Q features an I²C selectable low power shutdown mode that disables the device, reducing quiescent current consumption to 0.01µA. Set bit B4 (POWER_ON) in the Mode Control Register to 0 to disable the device. Set B0 to 1 to enable the device.

POWER DISSIPATION

The increase in power delivered by a BTL amplifier leads to a direct increase in internal power dissipation. The maximum power dissipation for a BTL amplifier for a given supply voltage and load is given by [Equation 2](#):

$$P_{\text{DMAX}} = 4 \times V_{\text{DD}}^2 / 2\pi^2 R_L \quad (\text{Watts}) \quad (2)$$

The maximum power dissipation of the HTSSOP package is calculated by [Equation 3](#):

$$P_{\text{DMAX (PKG)}} = T_{\text{JMAX}} - T_A / \theta_{\text{JA}} \quad (\text{Watts}) \quad (3)$$

where T_{JMAX} is 150°C, T_A is the ambient temperature and θ_{JA} is the thermal resistance specified in the *Absolute Maximum Ratings*.

If the power dissipation for a given operating condition exceeds the package maximum, either decrease the ambient temperature, increase air flow, add heat sinking to the device, or increase the load impedance and/or supply voltage. The LM48100Q HTSSOP package features an exposed die attach pad (DAP) that can be used to increase the maximum power dissipation of the package, see *Exposed DAP Mounting Considerations*.

The LM48100Q features thermal overload protection that disables the amplifier output stage when the die temperature exceeds +170°C. See the [Thermal Overload Detection](#) section.

PROPER SELECTION OF EXTERNAL COMPONENTS

Power Supply Bypassing/Filtering

Proper power supply bypassing is critical for low noise performance and high PSRR. Place the supply bypass capacitors as close to the device as possible. Place a 1µF ceramic capacitor from V_{DD} to GND. Additional bulk capacitance may be added as required.

Input Capacitor Selection

Input capacitors may be required for some applications, or when the audio source is single-ended. Input capacitors block the DC component of the audio signal, eliminating any conflict between the DC component of the audio source and the bias voltage of the LM48100Q. The input capacitors create a high-pass filter with the input resistors R_{IN} . The -3dB point of the high-pass filter is found using [Equation 4](#) below.

$$f = 1 / 2\pi R_{\text{IN}} C_{\text{IN}} \quad (\text{Hz}) \quad (4)$$

Where the value of R_{IN} is given in the *Electrical Characteristics Table*.

High pass filtering the audio signal helps protect the speakers. When the LM48100Q is using a single-ended source, power supply noise on the ground is seen as an input signal. Setting the high-pass filter point above the power supply noise frequencies, filters out the noise such that it is not amplified and heard on the output. Capacitors with a tolerance of 10% or better are recommended for impedance matching and improved PSRR.

Bias Capacitor Selection

The LM48100Q internally generates a $V_{\text{DD}}/2$ common-mode bias voltage. The BIAS capacitor C_{BIAS} , improves PSRR and THD+N by reducing noise at the BIAS node. Use a 2.2µF ceramic placed as close to the device as possible.

PCB Layout Guidelines

Minimize trace impedance of the power, ground and all output traces for optimum performance. Voltage loss due to trace resistance between the LM48100Q and the load results in decreased output power and efficiency. Trace resistance between the power supply and ground has the same effect as a poorly regulated supply, increased ripple and reduced peak output power. Use wide traces for power supply inputs and amplifier outputs to minimize losses due to trace resistance, as well as route heat away from the device. Proper grounding improves audio performance, minimizes crosstalk between channels and prevents digital noise from interfering with the audio signal. Use of power and ground planes is recommended.

Place all digital components and route digital signal traces as far as possible from analog components and traces. Do not run digital and analog traces in parallel on the same PCB layer. If digital and analog signal lines must cross either over or under each other, ensure that they cross in a perpendicular fashion.

Exposed Dap Mounting Considerations

The LM48100Q HTSSOP-EP package features an exposed die-attach (thermal) pad on its backside. The exposed pad provides a direct heat conduction path from the die to the PCB, reducing the thermal resistance of the package. Connect the exposed pad to GND with a large pad and via to a large GND plane on the bottom of the PCB for best heat distribution.

LM48100QTL Demoboard Bill of Materials

Designator	Quantity	Description
C1	1	10 μ F \pm 10% 16V Tantalum Capacitor (B Case) AVX TPSB106K016R0800
C2	1	1 μ F \pm 10% 16V X7R Ceramic Capacitor (603) Murata GRM188R71C105KA12D
C3, C5	2	0.1 μ F \pm 10% 16V X7R Ceramic Capacitor (603) Murata GRM188R71C104KA01D Panasonic ECJ-1VB1C104K
C4	1	2.2 μ F \pm 10% 16V X7R Ceramic Capacitor (603) Murata GRM188R71A225KE15D
C6, C7	2	0.1 μ F \pm 10% 50V X5R Ceramic Capacitor (1206) Murata GRM319R71H104KA01D
R1, R2	2	5k Ω \pm 5% 1/10W Thick Film Resistor (603) Vishay CRCW06035R1KJNEA
R3	1	1.5k Ω \pm 5% 1/10W Thick Film Resistor (603) Vishay CRCW06031K50JNEA
J2	1	16-Pin Boardmount Socket 3M 8516-4500JL
JU1	1	3-Pin Header
JU2–JU12	11	2 Pin Header
LM48100QMH	U1	LM48100QMH (14-Pin HTSSOP-EP)

Demo Board Schematic

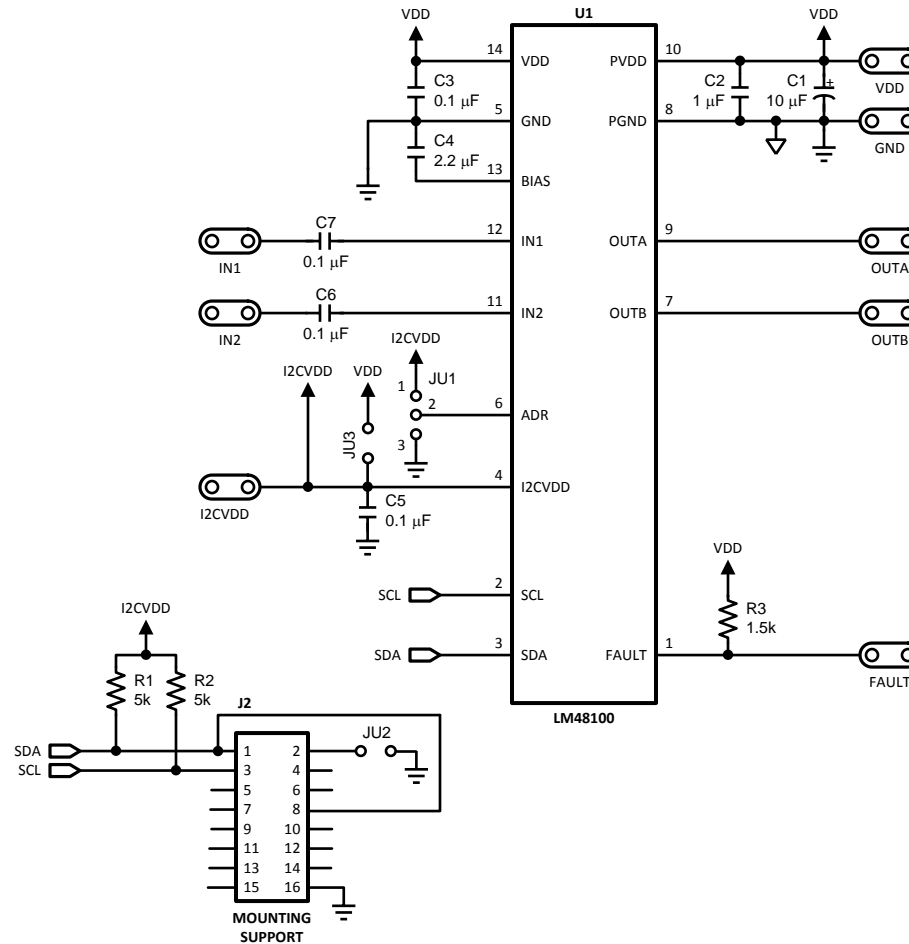

Figure 17. LM48100Q Demo Board Schematic

PC Board Layout

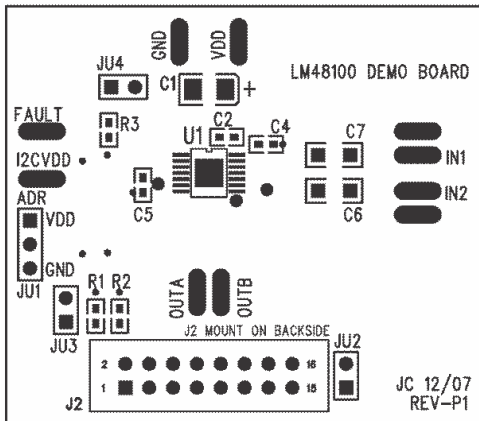

Figure 18. Top Silkscreen

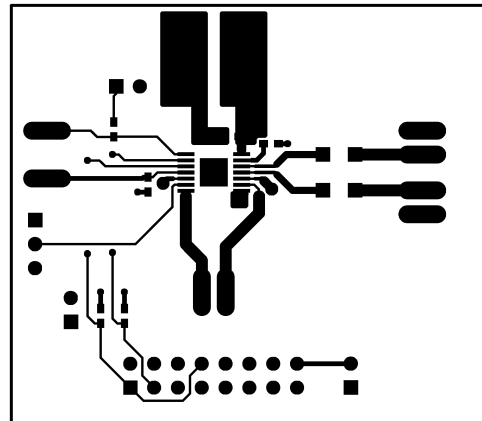

Figure 19. Top Layer

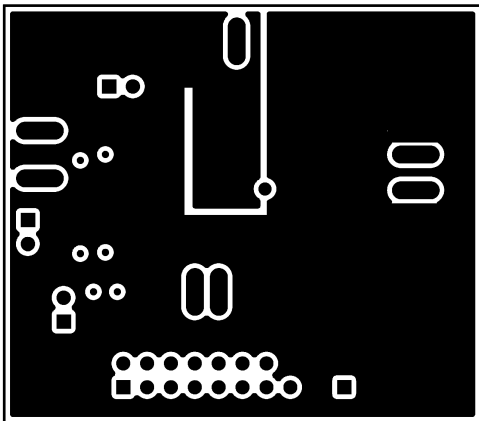

Figure 20. Layer 2

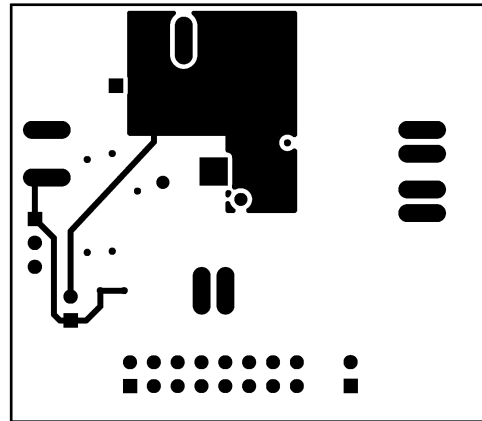

Figure 21. Layer 3

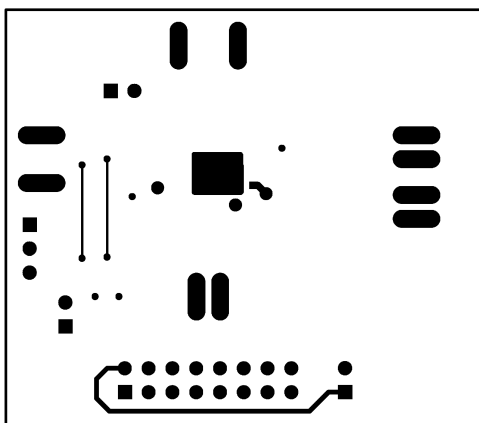

Figure 22. Bottom Layer

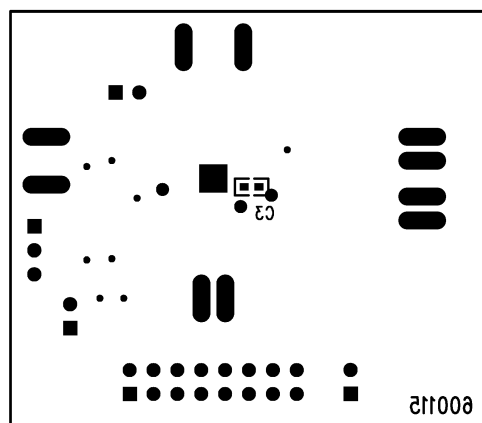

Figure 23. Bottom Silkscreen

Revision History

Rev	Date	Description
1.0	10/14/08	Initial release.
1.01	10/20/08	Text edits.
1.02	11/07/08	Added a column (Limits) in the Electrical tables.
1.03	11/12/08	Text edits.

PACKAGING INFORMATION

Orderable Device	Status (1)	Package Type	Package Drawing	Pins	Package Qty	Eco Plan (2)	Lead/Ball Finish	MSL Peak Temp (3)	Op Temp (°C)	Top-Side Markings (4)	Samples
LM48100QMH/NOPB	ACTIVE	HTSSOP	PWP	14	94	Green (RoHS & no Sb/Br)	CU SN	Level-1-260C-UNLIM	-40 to 105	L48100Q	Samples
LM48100QMHE/NOPB	ACTIVE	HTSSOP	PWP	14	250	Green (RoHS & no Sb/Br)	CU SN	Level-1-260C-UNLIM	-40 to 105	L48100Q	Samples
LM48100QMHX/NOPB	ACTIVE	HTSSOP	PWP	14	2500	Green (RoHS & no Sb/Br)	CU SN	Level-1-260C-UNLIM	-40 to 105	L48100Q	Samples

(1) The marketing status values are defined as follows:

ACTIVE: Product device recommended for new designs.

LIFEBUY: TI has announced that the device will be discontinued, and a lifetime-buy period is in effect.

NRND: Not recommended for new designs. Device is in production to support existing customers, but TI does not recommend using this part in a new design.

PREVIEW: Device has been announced but is not in production. Samples may or may not be available.

OBSOLETE: TI has discontinued the production of the device.

(2) Eco Plan - The planned eco-friendly classification: Pb-Free (RoHS), Pb-Free (RoHS Exempt), or Green (RoHS & no Sb/Br) - please check <http://www.ti.com/productcontent> for the latest availability information and additional product content details.

TBD: The Pb-Free/Green conversion plan has not been defined.

Pb-Free (RoHS): TI's terms "Lead-Free" or "Pb-Free" mean semiconductor products that are compatible with the current RoHS requirements for all 6 substances, including the requirement that lead not exceed 0.1% by weight in homogeneous materials. Where designed to be soldered at high temperatures, TI Pb-Free products are suitable for use in specified lead-free processes.

Pb-Free (RoHS Exempt): This component has a RoHS exemption for either 1) lead-based flip-chip solder bumps used between the die and package, or 2) lead-based die adhesive used between the die and leadframe. The component is otherwise considered Pb-Free (RoHS compatible) as defined above.

Green (RoHS & no Sb/Br): TI defines "Green" to mean Pb-Free (RoHS compatible), and free of Bromine (Br) and Antimony (Sb) based flame retardants (Br or Sb do not exceed 0.1% by weight in homogeneous material)

(3) MSL, Peak Temp. -- The Moisture Sensitivity Level rating according to the JEDEC industry standard classifications, and peak solder temperature.

(4) Only one of markings shown within the brackets will appear on the physical device.

Important Information and Disclaimer: The information provided on this page represents TI's knowledge and belief as of the date that it is provided. TI bases its knowledge and belief on information provided by third parties, and makes no representation or warranty as to the accuracy of such information. Efforts are underway to better integrate information from third parties. TI has taken and continues to take reasonable steps to provide representative and accurate information but may not have conducted destructive testing or chemical analysis on incoming materials and chemicals. TI and TI suppliers consider certain information to be proprietary, and thus CAS numbers and other limited information may not be available for release.

In no event shall TI's liability arising out of such information exceed the total purchase price of the TI part(s) at issue in this document sold by TI to Customer on an annual basis.

TAPE AND REEL INFORMATION

QUADRANT ASSIGNMENTS FOR PIN 1 ORIENTATION IN TAPE

*All dimensions are nominal

Device	Package Type	Package Drawing	Pins	SPQ	Reel Diameter (mm)	Reel Width W1 (mm)	A0 (mm)	B0 (mm)	K0 (mm)	P1 (mm)	W (mm)	Pin1 Quadrant
LM48100QMHE/NOPB	HTSSOP	PWP	14	250	178.0	12.4	6.95	8.3	1.6	8.0	12.0	Q1
LM48100QMHX/NOPB	HTSSOP	PWP	14	2500	330.0	12.4	6.95	8.3	1.6	8.0	12.0	Q1

TAPE AND REEL BOX DIMENSIONS

*All dimensions are nominal

Device	Package Type	Package Drawing	Pins	SPQ	Length (mm)	Width (mm)	Height (mm)
LM48100QMHE/NOPB	HTSSOP	PWP	14	250	203.0	190.0	41.0
LM48100QMHX/NOPB	HTSSOP	PWP	14	2500	349.0	337.0	45.0

PWP0014A

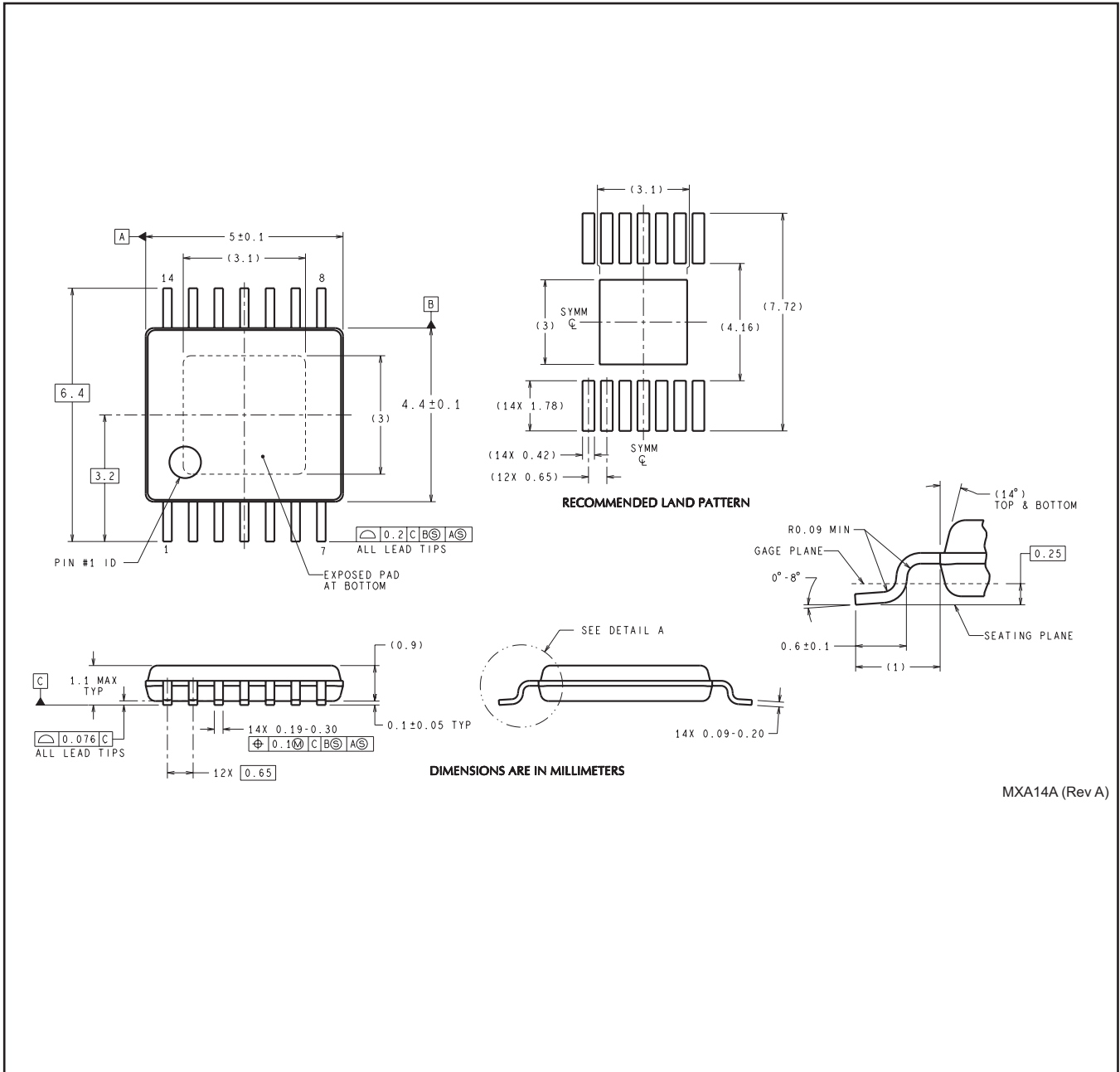

MXA14A (Rev A)

IMPORTANT NOTICE

Texas Instruments Incorporated and its subsidiaries (TI) reserve the right to make corrections, enhancements, improvements and other changes to its semiconductor products and services per JESD46, latest issue, and to discontinue any product or service per JESD48, latest issue. Buyers should obtain the latest relevant information before placing orders and should verify that such information is current and complete. All semiconductor products (also referred to herein as "components") are sold subject to TI's terms and conditions of sale supplied at the time of order acknowledgment.

TI warrants performance of its components to the specifications applicable at the time of sale, in accordance with the warranty in TI's terms and conditions of sale of semiconductor products. Testing and other quality control techniques are used to the extent TI deems necessary to support this warranty. Except where mandated by applicable law, testing of all parameters of each component is not necessarily performed.

TI assumes no liability for applications assistance or the design of Buyers' products. Buyers are responsible for their products and applications using TI components. To minimize the risks associated with Buyers' products and applications, Buyers should provide adequate design and operating safeguards.

TI does not warrant or represent that any license, either express or implied, is granted under any patent right, copyright, mask work right, or other intellectual property right relating to any combination, machine, or process in which TI components or services are used. Information published by TI regarding third-party products or services does not constitute a license to use such products or services or a warranty or endorsement thereof. Use of such information may require a license from a third party under the patents or other intellectual property of the third party, or a license from TI under the patents or other intellectual property of TI.

Reproduction of significant portions of TI information in TI data books or data sheets is permissible only if reproduction is without alteration and is accompanied by all associated warranties, conditions, limitations, and notices. TI is not responsible or liable for such altered documentation. Information of third parties may be subject to additional restrictions.

Resale of TI components or services with statements different from or beyond the parameters stated by TI for that component or service voids all express and any implied warranties for the associated TI component or service and is an unfair and deceptive business practice. TI is not responsible or liable for any such statements.

Buyer acknowledges and agrees that it is solely responsible for compliance with all legal, regulatory and safety-related requirements concerning its products, and any use of TI components in its applications, notwithstanding any applications-related information or support that may be provided by TI. Buyer represents and agrees that it has all the necessary expertise to create and implement safeguards which anticipate dangerous consequences of failures, monitor failures and their consequences, lessen the likelihood of failures that might cause harm and take appropriate remedial actions. Buyer will fully indemnify TI and its representatives against any damages arising out of the use of any TI components in safety-critical applications.

In some cases, TI components may be promoted specifically to facilitate safety-related applications. With such components, TI's goal is to help enable customers to design and create their own end-product solutions that meet applicable functional safety standards and requirements. Nonetheless, such components are subject to these terms.

No TI components are authorized for use in FDA Class III (or similar life-critical medical equipment) unless authorized officers of the parties have executed a special agreement specifically governing such use.

Only those TI components which TI has specifically designated as military grade or "enhanced plastic" are designed and intended for use in military/aerospace applications or environments. Buyer acknowledges and agrees that any military or aerospace use of TI components which have **not** been so designated is solely at the Buyer's risk, and that Buyer is solely responsible for compliance with all legal and regulatory requirements in connection with such use.

TI has specifically designated certain components as meeting ISO/TS16949 requirements, mainly for automotive use. In any case of use of non-designated products, TI will not be responsible for any failure to meet ISO/TS16949.

Products

Audio	www.ti.com/audio
Amplifiers	amplifier.ti.com
Data Converters	dataconverter.ti.com
DLP® Products	www.dlp.com
DSP	dsp.ti.com
Clocks and Timers	www.ti.com/clocks
Interface	interface.ti.com
Logic	logic.ti.com
Power Mgmt	power.ti.com
Microcontrollers	microcontroller.ti.com
RFID	www.ti-rfid.com
OMAP Applications Processors	www.ti.com/omap
Wireless Connectivity	www.ti.com/wirelessconnectivity

Applications

Automotive and Transportation	www.ti.com/automotive
Communications and Telecom	www.ti.com/communications
Computers and Peripherals	www.ti.com/computers
Consumer Electronics	www.ti.com/consumer-apps
Energy and Lighting	www.ti.com/energy
Industrial	www.ti.com/industrial
Medical	www.ti.com/medical
Security	www.ti.com/security
Space, Avionics and Defense	www.ti.com/space-avionics-defense
Video and Imaging	www.ti.com/video

TI E2E Community

e2e.ti.com