

LM4250/LM4250C Programmable Operational Amplifier

General Description

The LM4250 and LM4250C are extremely versatile programmable monolithic operational amplifiers. A single external master bias current setting resistor programs the input bias current, input offset current, quiescent power consumption, slew rate, input noise, and the gain-bandwidth product. The device is a truly general purpose operational amplifier.

The LM4250C is identical to the LM4250 except that the LM4250C has its performance guaranteed over a 0°C to +70°C temperature range instead of the -55°C to +125°C temperature range of the LM4250.

Features

- $\pm 1\text{V}$ to $\pm 18\text{V}$ power supply operation
- 3 nA input offset current
- Standby power consumption as low as 500 nW
- No frequency compensation required
- Programmable electrical characteristics
- Offset voltage nulling capability
- Can be powered by two flashlight batteries
- Short circuit protection

Typical Applications

X5 Difference Amplifier

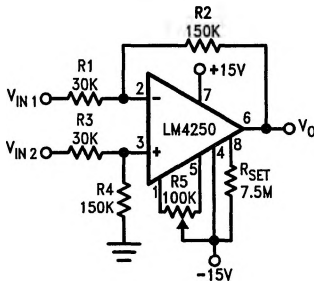

Quiescent $P_D = 0.6 \text{ mW}$

TL/H/9300-3

500 Nano-Watt X10 Amplifier

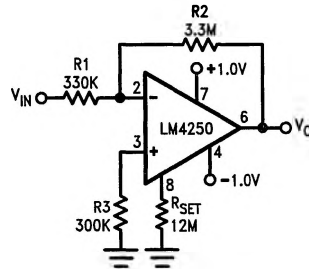

Quiescent $P_P = 500 \text{ mW}$

TL/H/9300-4

Connection Diagrams

Metal Can Package

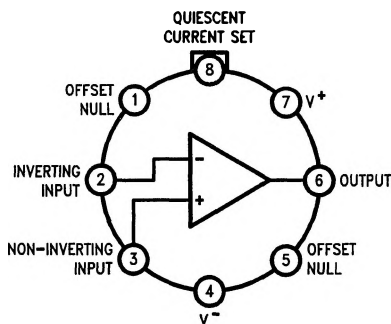

Top View

Order Number LM4250H or LM4250CH
See NS Package Number H08C

TL/H/9300-2

Dual-In-Line Package

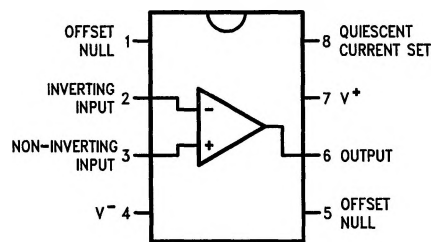

Top View

Order Number LM4250J, LM4250CJ,
LM4250CN or LM4250M
See NS Package Number J08A, M08A or N08E

TL/H/9300-5

Absolute Maximum Ratings

If Military/Aerospace specified devices are required, please contact the National Semiconductor Sales Office/Distributors for availability and specifications.
(Note 2)

	LM4250	LM4250C
Supply Voltage	± 18V	± 18V
Operating Temp. Range	-55°C ≤ T _A ≤ +125°C	0°C ≤ T _A ≤ +70°C
Differential Input Voltage	± 30V	± 30V
Input Voltage (Note 1)	± 15V	± 15V
I _{SET} Current	150 nA	150 nA
Output Short Circuit Duration	Continuous	Continuous
T _{JMAX}		
H-Package	150°C	100°C
N-Package		100°C
J-Package	150°C	100°C
M-Package		100°C
Power Dissipation at T _A = 25°C		
H-Package (Still Air)	500 mW	300 mW
(400 LF/Min Air Flow)	1200 mW	1200 mW
N-Package		500 mW
J-Package	1000 mW	600 mW
M-Package		350 mW
Thermal Resistance (Typical) θ _{JA}		
H-Package (Still Air)	165°C/W	165°C/W
(400 LF/Min Air Flow)	65°C/W	65°C/W
N-Package		130°C/W
J-Package	108°C/W	108°C/W
M-Package		190°C/W
(Typical) θ _{JC}		
H-Package	21°C/W	21°C/W
Storage Temperature Range	-65°C to +150°C	-65°C to +150°C
Soldering Information		
Dual-In-Line Package		
Soldering (10 seconds)	260°C	
Small Outline Package		
Vapor Phase (60 seconds)	215°C	
Infrared (15 seconds)	220°C	
See AN-450 "Surface Mounting Methods and Their Effect on Product Reliability" for other methods of soldering surface mount devices.		
ESD tolerance (Note 3)	800V	

Note 1: For supply voltages less than ± 15V, the absolute maximum input voltage is equal to the supply voltage.

Note 2: Refer to RETS4250X for military specifications.

Note 3: Human body model, 1.5 kΩ in series with 100 pF.

Resistor Biasing

Set Current Setting Resistor to V⁻

V _S	I _{SET}				
	0.1 μA	0.5 μA	1.0 μA	5 μA	10 μA
± 1.5V	25.6 MΩ	5.04 MΩ	2.5 MΩ	492 kΩ	244 kΩ
± 3.0V	55.6 MΩ	11.0 MΩ	5.5 MΩ	1.09 MΩ	544 kΩ
± 6.0V	116 MΩ	23.0 MΩ	11.5 MΩ	2.29 MΩ	1.14 MΩ
± 9.0V	176 MΩ	35.0 MΩ	17.5 MΩ	3.49 MΩ	1.74 MΩ
± 12.0V	236 MΩ	47.0 MΩ	23.5 MΩ	4.69 MΩ	2.34 MΩ
± 15.0V	296 MΩ	59.0 MΩ	29.5 MΩ	5.89 MΩ	2.94 MΩ

Electrical Characteristics LM4250 ($0^{\circ}\text{C} \leq T_A \leq +70^{\circ}\text{C}$ unless otherwise specified.) $T_A = T_J$

Parameter	Conditions	$V_S = \pm 1.5\text{V}$			
		$I_{SET} = 1\ \mu\text{A}$		$I_{SET} = 10\ \mu\text{A}$	
		Min	Max	Min	Max
V_{OS}	$R_S \leq 100\ \text{k}\Omega$, $T_A = 25^{\circ}\text{C}$		3 mV		5 mV
I_{OS}	$T_A = 25^{\circ}\text{C}$		3 nA		10 nA
I_{bias}	$T_A = 25^{\circ}\text{C}$		7.5 nA		50 nA
Large Signal Voltage Gain	$R_L = 100\ \text{k}\Omega$, $T_A = 25^{\circ}\text{C}$ $V_O = \pm 0.6\text{V}$, $R_L = 10\ \text{k}\Omega$	40k		50k	
Supply Current	$T_A = 25^{\circ}\text{C}$		7.5 μA		80 μA
Power Consumption	$T_A = 25^{\circ}\text{C}$		23 μW		240 μW
V_{OS}	$R_S \leq 100\ \text{k}\Omega$		4 mV		6 mV
I_{OS}	$T_A = +125^{\circ}\text{C}$ $T_A = -55^{\circ}\text{C}$		5 nA 3 nA		10 nA 10 nA
I_{bias}			7.5 nA		50 nA
Input Voltage Range		$\pm 0.6\text{V}$		$\pm 0.6\text{V}$	
Large Signal Voltage Gain	$V_O = \pm 0.5\text{V}$, $R_L = 100\ \text{k}\Omega$ $R_L = 10\ \text{k}\Omega$	30k		30k	
Output Voltage Swing	$R_L = 100\ \text{k}\Omega$ $R_L = 10\ \text{k}\Omega$	$\pm 0.6\text{V}$		$\pm 0.6\text{V}$	
Common Mode Rejection Ratio	$R_S \leq 10\ \text{k}\Omega$	70 dB		70 dB	
Supply Voltage Rejection Ratio	$R_S \leq 10\ \text{k}\Omega$	76 dB		76 dB	
Supply Current			8 μA		90 μA
Power Consumption			24 μW		270 μW

Parameter	Conditions	$V_S = \pm 15\text{V}$			
		$I_{SET} = 1\ \mu\text{A}$		$I_{SET} = 10\ \mu\text{A}$	
		Min	Max	Min	Max
V_{OS}	$R_S \leq 100\ \text{k}\Omega$, $T_A = 25^{\circ}\text{C}$		3 mV		5 mV
I_{OS}	$T_A = 25^{\circ}\text{C}$		3 nA		10 nA
I_{bias}	$T_A = 25^{\circ}\text{C}$		7.5 nA		50 nA
Large Signal Voltage Gain	$R_L = 100\ \text{k}\Omega$, $T_A = 25^{\circ}\text{C}$ $V_O = \pm 10\text{V}$, $R_L = 10\ \text{k}\Omega$	100k		100k	
Supply Current	$T_A = 25^{\circ}\text{C}$		10 μA		90 μA
Power Consumption	$T_A = 25^{\circ}\text{C}$		300 μW		2.7 mW
V_{OS}	$R_S \leq 100\ \text{k}\Omega$		4 mV		6 mV
I_{OS}	$T_A = +125^{\circ}\text{C}$ $T_A = -55^{\circ}\text{C}$		25 nA 3 nA		25 nA 10 nA
I_{bias}			7.5 nA		50 nA
Input Voltage Range		$\pm 13.5\text{V}$		$\pm 13.5\text{V}$	
Large Signal Voltage Gain	$V_O = \pm 10\text{V}$, $R_L = 100\ \text{k}\Omega$ $R_L = 10\ \text{k}\Omega$	50k		50k	
Output Voltage Swing	$R_L = 100\ \text{k}\Omega$ $R_L = 10\ \text{k}\Omega$	$\pm 12\text{V}$		$\pm 12\text{V}$	
Common Mode Rejection Ratio	$R_S \leq 10\ \text{k}\Omega$	70 dB		70 dB	
Supply Voltage Rejection Ratio	$R_S \leq 10\ \text{k}\Omega$	76 dB		76 dB	
Supply Current			11 μA		100 μA
Power Consumption			330 μW		3 mW

Electrical Characteristics LM4250C ($-55^{\circ}\text{C} \leq T_A \leq +125^{\circ}\text{C}$ unless otherwise specified.) $T_A = T_J$

Parameter	Conditions	$V_S = \pm 1.5\text{V}$			
		$I_{\text{SET}} = 1\ \mu\text{A}$		$I_{\text{SET}} = 10\ \mu\text{A}$	
		Min	Max	Min	Max
V_{OS}	$R_S \leq 100\ \text{k}\Omega, T_A = 25^{\circ}\text{C}$		5 mV		6 mV
I_{OS}	$T_A = 25^{\circ}\text{C}$		6 nA		20 nA
I_{bias}	$T_A = 25^{\circ}\text{C}$		10 nA		75 nA
Large Signal Voltage Gain	$R_L = 100\ \text{k}\Omega, T_A = 25^{\circ}\text{C}$ $V_O = \pm 0.6\text{V}, R_L = 10\ \text{k}\Omega$	25k		25k	
Supply Current	$T_A = 25^{\circ}\text{C}$		8 μA		90 μA
Power Consumption	$T_A = 25^{\circ}\text{C}$		24 μW		270 μW
V_{OS}	$R_S \leq 10\ \text{k}\Omega$		6.5 mV		7.5 mV
I_{OS}			8 nA		25 nA
I_{bias}			10 nA		80 nA
Input Voltage Range		$\pm 0.6\text{V}$		$\pm 0.6\text{V}$	
Large Signal Voltage Gain	$V_O = \pm 0.5\text{V}, R_L = 100\ \text{k}\Omega$ $R_L = 10\ \text{k}\Omega$	25k		25k	
Output Voltage Swing	$R_L = 100\ \text{k}\Omega$ $R_L = 10\ \text{k}\Omega$	$\pm 0.6\text{V}$		$\pm 0.6\text{V}$	
Common Mode Rejection Ratio	$R_S \leq 10\ \text{k}\Omega$	70 dB		70 dB	
Supply Voltage Rejection Ratio	$R_S \leq 10\ \text{k}\Omega$	74 dB		74 dB	
Supply Current			8 μA		90 μA
Power Consumption			24 μW		270 μW

Parameter	Conditions	$V_S = \pm 15\text{V}$			
		$I_{\text{SET}} = 1\ \mu\text{A}$		$I_{\text{SET}} = 10\ \mu\text{A}$	
		Min	Max	Min	Max
V_{OS}	$R_S \leq 100\ \text{k}\Omega, T_A = 25^{\circ}\text{C}$		5 mV		6 mV
I_{OS}	$T_A = 25^{\circ}\text{C}$		6 nA		20 nA
I_{bias}	$T_A = 25^{\circ}\text{C}$		10 nA		75 nA
Large Signal Voltage Gain	$R_L = 100\ \text{k}\Omega, T_A = 25^{\circ}\text{C}$ $V_O = \pm 10\text{V}, R_L = 10\ \text{k}\Omega$	60k		60k	
Supply Current	$T_A = 25^{\circ}\text{C}$		11 μA		100 μA
Power Consumption	$T_A = 25^{\circ}\text{C}$		330 μW		3 mW
V_{OS}	$R_S \leq 100\ \text{k}\Omega$		6.5 mV		7.5 mV
I_{OS}			8 nA		25 nA
I_{bias}			10 nA		80 nA
Input Voltage Range		$\pm 13.5\text{V}$		$\pm 13.5\text{V}$	
Large Signal Voltage Gain	$V_O = \pm 10\text{V}, R_L = 100\ \text{k}\Omega$ $R_L = 10\ \text{k}\Omega$	50k		50k	
Output Voltage Swing	$R_L = 100\ \text{k}\Omega$ $R_L = 10\ \text{k}\Omega$	$\pm 12\text{V}$		$\pm 12\text{V}$	
Common Mode Rejection Ratio	$R_S \leq 10\ \text{k}\Omega$	70 dB		70 dB	
Supply Voltage Rejection Ratio	$R_S \leq 10\ \text{k}\Omega$	74 dB		74 dB	
Supply Current			11 μA		100 μA
Power Consumption			330 μW		3 mW

Typical Performance Characteristics

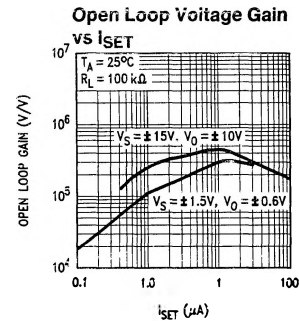
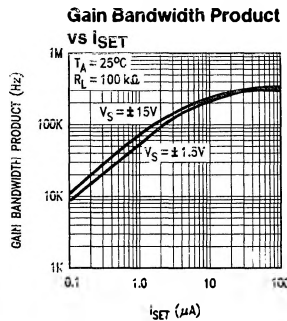
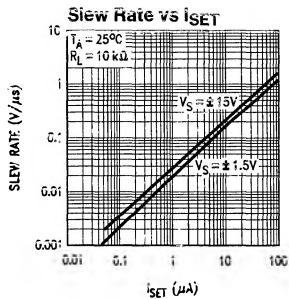
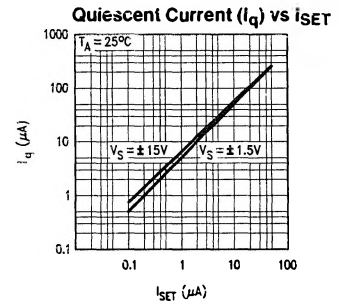
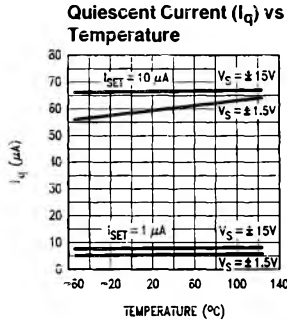
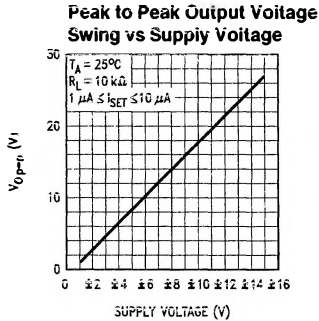
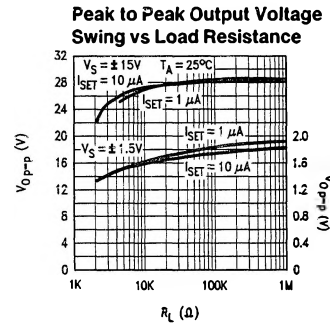
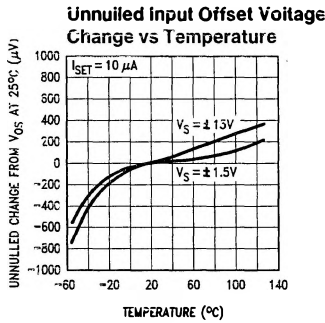
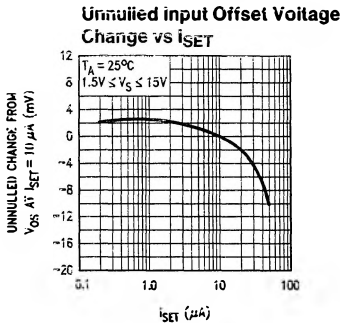
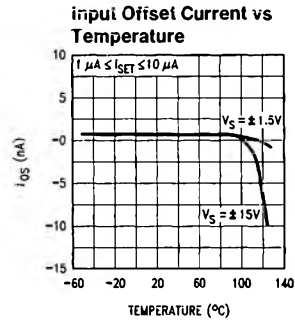
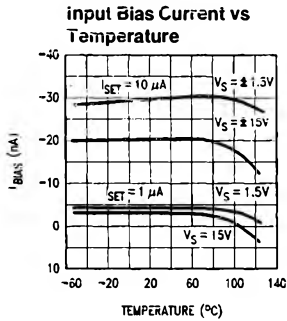
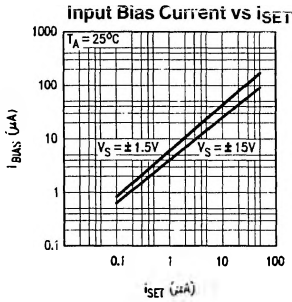

Typical Performance Characteristics (Continued)

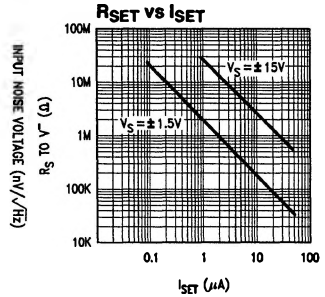
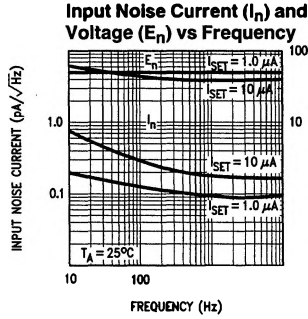
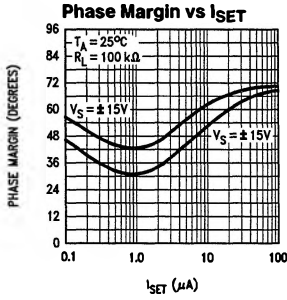

TL/H/9300-7

Typical Applications (Continued)

Floating Input Meter Amplifier 100 nA Full Scale

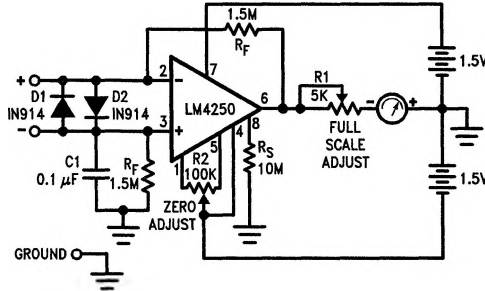

Quiescent $P_D = 1.8\ \mu\text{W}$

*Meter movement (0-100 μA, 2 kΩ) marked for 0-100 nA full scale.

TL/H/9300-8

X100 Instrumentation Amplifier 10 μW

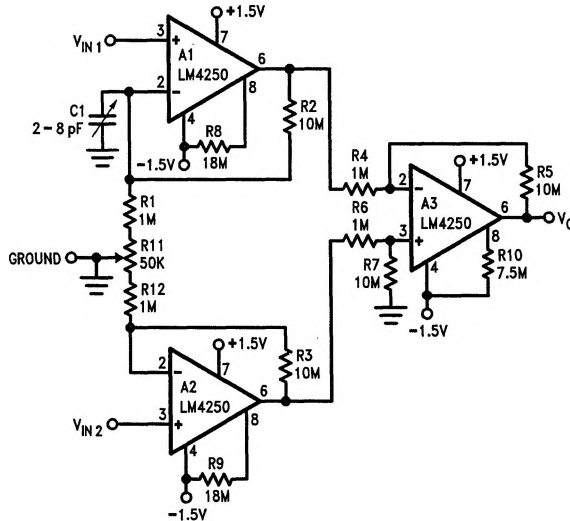

Note 1: Quiescent $P_D = 10\ \mu\text{W}$.

Note 2: R2, R3, R4, R5, R6 and R7 are 1% resistors.

Note 3: R11 and C1 are for DC and AC common mode rejection adjustments.

TL/H/9300-9

Typical Applications (Continued)

R_{SET} Connected to V⁻

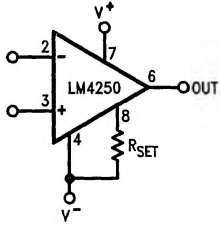

TL/H/9300-10

R_{SET} Connected to Ground

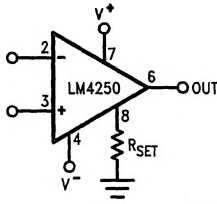

TL/H/9300-11

I_{SET} Equations:

$$I_{SET} \approx \frac{V^+ + |V^-| - 0.5}{R_{SET}} \quad \text{where } R_{SET} \text{ is connected to } V^-$$

$$I_{SET} \approx \frac{V^+ - 0.5}{R_{SET}} \quad \text{where } R_{SET} \text{ is connected to ground.}$$

Transistor Current Sourcing Biasing

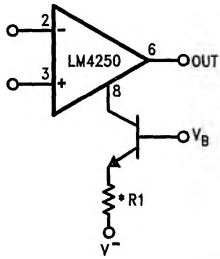

TL/H/9300-12

FET Current Sourcing Biasing

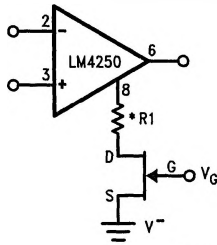

TL/H/9300-13

Offset Null Circuit

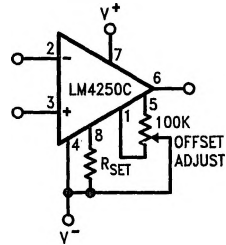

TL/H/9300-14

*R₁ limits I_{SET} maximum

Schematic Diagram

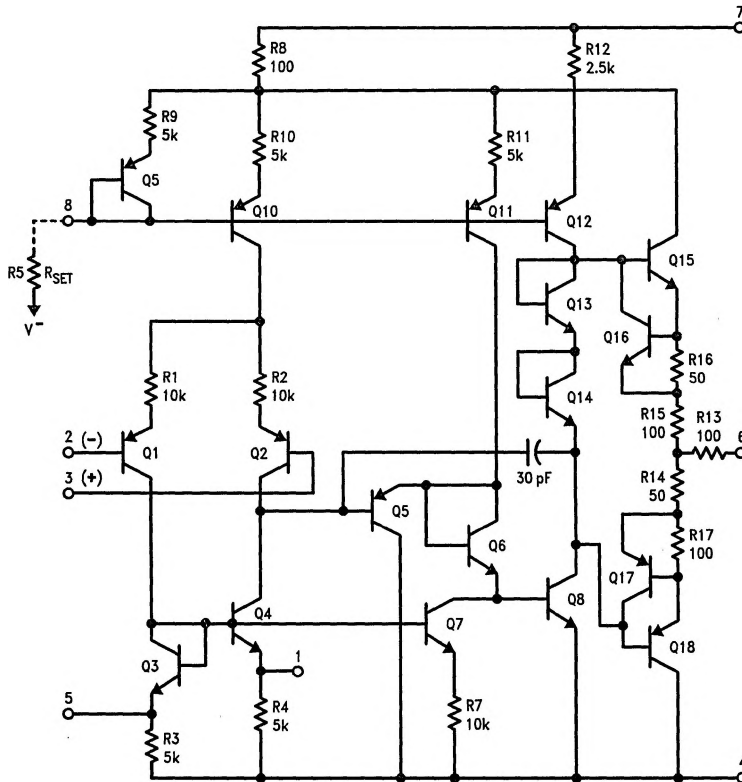

TL/H/9300-1