

LM3686 Step-Down DC-DC Converter with Integrated Post Linear Regulators System and Low-Noise Linear Regulator

 Check for Samples: [LM3686](#)

FEATURES

DC-DC REGULATOR

- $V_{OUT_DCDC} = 1.2V$ to $2.5V$ (in 100 mV Steps - Factory Programmed)
- 600 mA Maximum Load Capability (LILO = OFF)
- 3 MHz PWM Fixed Switching Frequency (Typ.)
- Automatic PFM/PWM Mode Switching
- Internal Synchronous Rectification for High Efficiency
- Internal Soft Start

DUAL RAIL LINEAR REGULATOR: LILO

- Load Transients < 50 mV Peak Typ.
- Line Transients < 1 mV Peak Typ.
- $V_{OUT_LILO} = 0.7V$ to $2.0V$ (in 50 mV Steps - Factory Programmed)
- 70 μA Typical I_Q From V_{IN_LILO}
- 350 mA Maximum Load Capability (Large FET)

LINEAR REGULATOR: LDO

- Load Transients < 80 mV Peak Typ.
- Line Transients < 1 mV Peak Typ.
- $V_{OUT_LDO} = 1.5V$ to $3.3V$ (in 100 mV Steps - Factory Programmed)

- 50 μA Typical I_Q
 - 300 mA Maximum Load Capability
- ### COMBINED GLOBAL FEATURES
- $V_{BATT} \geq V_{OUT_LILO} + 1.5V$ or $2.7V$, Whichever is Higher
 - 900 mA Maximum Combined Load Capability
 - Operates From a Single Li-Ion Cell or 3 Cell NiMH/NiCd Batteries
 - Only Six Tiny Surface-mount External Components Required (One Inductor, Five Ceramic Capacitors)
 - 12-bump DSBGA
 - 100 μA I_Q From V_{BATT}
 - 15.66 mm² Total Solution Size

APPLICATIONS

- Mobile TV
- Hand-Held Radios
- Personal Digital Assistants
- Palm-top PCs
- Portable Instruments
- Battery-Powered Devices
- Portable Personal Clients

DESCRIPTION

The LM3686 is a step-down DC-DC converter with one integrated very low dropout linear regulator and a low noise linear regulator optimized for powering ultra-low voltage circuits from a single Li-Ion cell or 3 cell NiMH/NiCd batteries. It provides three outputs with combined load current up to 900 mA over an input voltage range from 2.7V to 5.5V.

The device offers superior features and performance for many applications. Automatic intelligent switching between PWM low-noise and PFM low-current mode offers improved system control. During full-power operation, a fixed-frequency 3 MHz (typ.), PWM mode drives loads from ~70 mA to 600 mA max. Hysteretic PFM mode extends the battery life through reduction of the quiescent current to 28 μA (typ.) at light load and system standby. Internal synchronous rectification provides high efficiency.

Three enable pins allow the separate operation of either the DC-DC, post-regulation linear regulator or the linear regulator alone. If the DC-DC is not enabled during startup of the post-regulation linear regulator, a parallel small pass transistor supplies the linear regulator from V_{BATT} with maximal 50 mA. In the combined operation where both enables are raised together, the small pass transistor is deactivated and the big pass transistor provides 350 mA output current. In shutdown mode (Enable pins pulled low), the device turns off and reduces battery consumption to 2.5 μA (typ.).



Please be aware that an important notice concerning availability, standard warranty, and use in critical applications of Texas Instruments semiconductor products and disclaimers thereto appears at the end of this data sheet.

All trademarks are the property of their respective owners.

The LM3686 is available in a 12-bump DSBGA package. A high-switching frequency of 3 MHz (typ.) allows the use of a few tiny surface-mount components. Only six external surface-mount components, an inductor and five ceramic capacitors, are required to establish a 15.66 mm² total solution size.

Typical Application Circuit

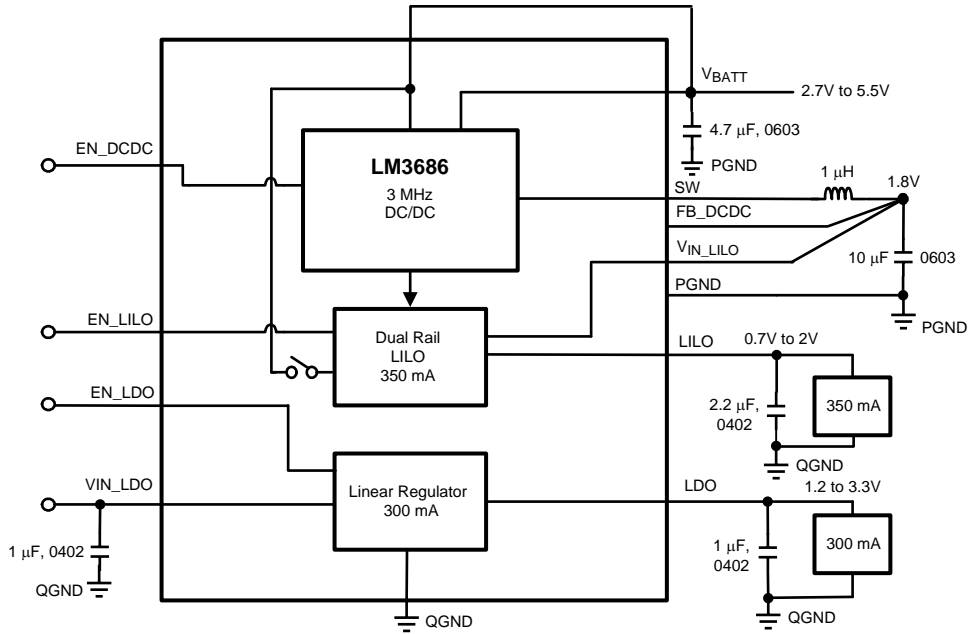

Figure 1. Typical Application

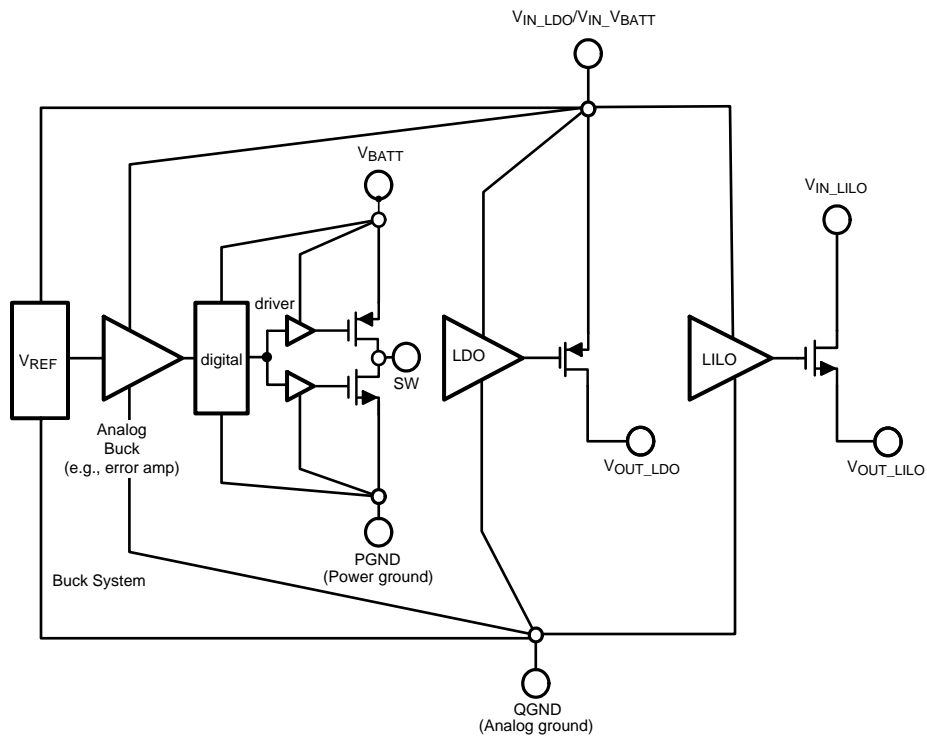

Figure 2. Functional Diagram (Always Connect V_{IN_LDO} to V_{BATT})

Connection Diagram

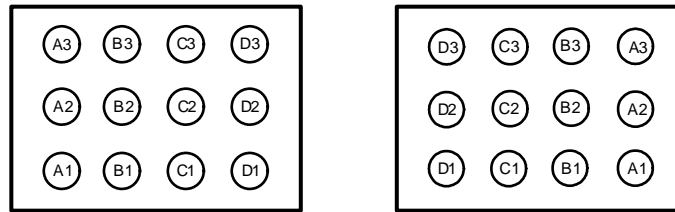

Figure 3. 12-pin DSBGA Package
See Package Number YZR0012

PIN DESCRIPTIONS

Pin Number	Symbol	Name and Function
A1	PGND	Power Ground pin
A2	SW	Switching node connection to the internal PFET switch and NFET synchronous rectifier.
A3	FB_DCDC	Feedback analog input for the DC-DC converter. Connect to the output filter capacitor.
B1	V _{BATT}	Power supply input for switcher. Connect to the input filter capacitor.
B2	EN_LILO	Enable input for the linear regulator. The linear regulator is in shutdown mode if voltage at this pin is < 0.4V and enabled if > 1.1V. Do not leave this pin floating.
B3	EN_DCDC	Enable input for the DC-DC converter. The DC-DC converter is in shutdown mode if voltage at this pin is < 0.4V and enabled if > 1.1V. Do not leave this pin floating.
C1	V _{IN_LDO}	Input power to LDO. (Must tie to V _{BATT} at all times)
C2	EN_LDO	Enable input for the linear regulator. The linear regulator is in shutdown mode if voltage at this pin is < 0.4V and enabled if > 1.1V. Do not leave this pin floating.
C3	QGND	Quiet GND pin for LDO and reference circuit.
D1	V _{OUT_LDO}	Voltage output of the linear regulator.
D2	V _{OUT_LILO}	Voltage output of the low input linear regulator
D3	V _{IN_LILO}	Input power to LILO (V _{IN_LILO} connects to output of DCDC or standalone).

Enable Combinations

EN_DCDC	EN_LILO	EN_LDO	Function
0	0	0	No Outputs
0	0	1	Linear Regulator enabled only (EN_LDO), supply from V _{IN_LDO} , I _{OUT_MAX} = 300 mA
0	1	0	Linear Regulator enabled only LILO supplies from V _{IN_LDO} , I _{OUT_MAX} = 50 mA, V _{IN_LDO} > = V _{OUT_LILO}
1	0	0	DC-DC converter enabled only
1	1	0	Linear Regulator & DCDC enabled 1) V _{IN_LILO} < V _{OUT_LILO} + 150 mV (typ.), the small NMOS device is active (I _{MAX} = 50 mA) and supplied by V _{IN_LDO} . 2) If V _{IN_LILO} > V _{OUT_LILO} + 250 mV (typ.), the large NMOS device is active (I _{MAX} = 350 mA) and supplied by V _{IN_LILO} . Maxium current of DC-DC when EN_LILO = High is 250 mA ⁽¹⁾⁽²⁾
1	1	1	DC-DC converter and linear regulator active. Linear regulator starts after DC-DC converter.

- (1) The LILO is turned on via a small NMOS device supplied by V_{IN_LDO}. The maximum current is 50 mA when this small NMOS is ON. If higher current > 50 mA is desired the following condition must be done: EN_DC = HIGH .
- (2) When the switcher is enabled, a transition occurs from the small NMOS to a larger NMOS. The transition occurs when V_{IN_LILO} > V_{OUT_LILO} + 250 mV. If V_{IN_LILO} < V_{OUT_LILO} + 150 mV, the LILO switches back to small NMOS (Switcher EN = low).

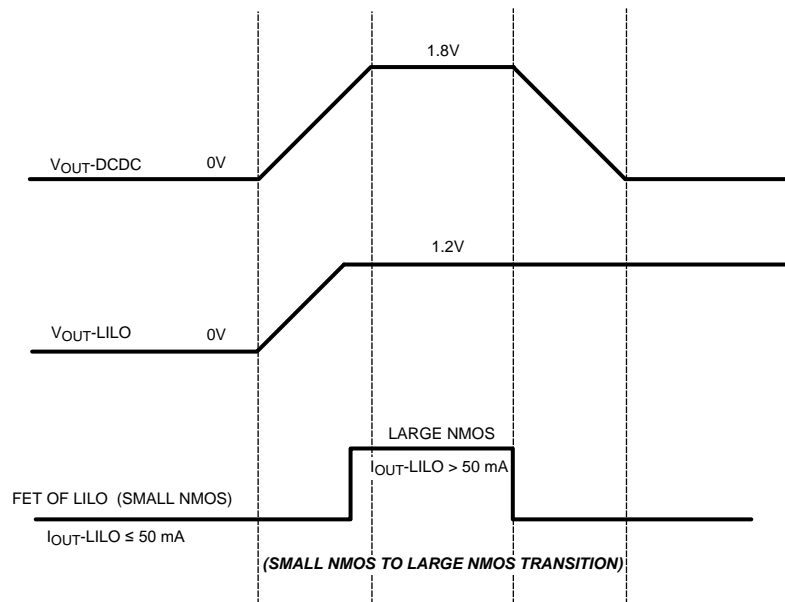

Figure 4. Mode Transition



These devices have limited built-in ESD protection. The leads should be shorted together or the device placed in conductive foam during storage or handling to prevent electrostatic damage to the MOS gates.

Absolute Maximum Ratings⁽¹⁾⁽²⁾⁽³⁾

V_{BATT} pin to GND and QGND	-0.2V to 6.0V
Enable pins, Feedback pins, SW pin	(GND-0.2V) to ($V_{BATT}+0.2V$) with 6.0V max
Junction Temperature (T_{J-MAX})	150°C
Storage Temperature Range	-65°C to + 150°C
Continuous Power Dissipation ⁽⁴⁾	Internally Limited
Maximum Lead Temperature (Soldering)	See ⁽⁵⁾

- (1) Absolute Maximum Ratings indicate limits beyond which damage to the component may occur. Operating Ratings are conditions under which operation of the device is guaranteed. Operating Ratings do not imply guaranteed performance limits. For guaranteed performance limits and associated test conditions, see the Electrical Characteristics tables.
- (2) All voltages are with respect to the potential at the GND pin.
- (3) If Military/Aerospace specified devices are required, please contact the Texas Instruments Sales Office/Distributors for availability and specifications.
- (4) Internal thermal shutdown circuitry protects the device from permanent damage. Thermal shutdown engages at $T_J = 150^\circ\text{C}$ (typ.) and disengages at $T_J = 130^\circ\text{C}$ (typ.).
- (5) For detailed soldering specifications and information, see the TI AN-1112 Application Report ([SNVA009](#)).

Operating Ratings

Input Voltage Range V_{BATT} (DC-DC & LDO)	2.7V to 5.5V
Junction Temperature (T_J) Range	-40°C to + 125°C
Ambient Temperature (T_A) Range ⁽¹⁾	-40°C to + 85°C

- (1) In applications where high power dissipation and/or poor package thermal resistance is present, the maximum ambient temperature may have to be derated. Maximum ambient temperature (T_{A-MAX}) is dependent on the maximum operating junction temperature ($T_{J-MAX-OP} = 125^\circ\text{C}$), the maximum power dissipation of the device in the application (P_{D-MAX}), and the junction-to ambient thermal resistance of the part/package in the application (θ_{JA}), as given by the following equation: $T_{A-MAX} = T_{J-MAX-OP} - (\theta_{JA} \times P_{D-MAX})$.

Thermal Properties

Junction-to-Ambient Thermal Resistance (θ_{JA}) ⁽¹⁾	
DSBGA 12	120°C/W

- (1) Junction-to-ambient thermal resistance is highly application and board-layout dependent. In applications where high maximum power dissipation exists, special attention must be paid to thermal dissipation issues in board design.

Electrical Characteristics

Linear Regulator — LILO (EN_DCDC = EN_LILO = ON - Large NMOS)⁽¹⁾⁽²⁾⁽³⁾⁽⁴⁾

Limits in standard typeface are for $T_A = 25^\circ\text{C}$. Limits appearing in **boldface** type apply over the full operating ambient temperature range: $-40^\circ\text{C} \leq T_A = T_J \leq +85^\circ\text{C}$. Unless otherwise noted, specifications apply to the closed loop typical application circuits (linear regulator) with $V_{IN_LDO} = V_{BATT} = 3.6\text{V}^{(5)}$, $V_{IN_LILO} = V_{OUT_DCDC(NOM)}$, $V_{EN(AII)} = V_{BATT}$, $C_{IN_DC} = 4.7\ \mu\text{F}$, $C_{OUT_LILO} = 2.2\ \mu\text{F}$, $C_{IN_LDO} = 1.0\ \mu\text{F}$, $C_{OUT_LDO} = 1.0\ \mu\text{F}$, $C_{OUT_DC} = C_{IN_LILO} = 10\ \mu\text{F}$

Symbol	Parameter	Condition	Limits			Units
			Min	Typ	Max	
$\Delta V_{OUT_LILO} / V_{OUT_LILO}$	Output Voltage Accuracy, V_{OUT_LILO}	$I_{OUT_LILO} = 1\ \text{mA to } 350\ \text{mA}$ $V_{IN_LILO} = V_{OUT_DCDC}$ $V_{BATT} = 3.6\text{V}$	1.176	1.2	1.224	V
$\Delta V_{OUT_LILO} / \Delta \text{mA}$	Load Regulation ⁽⁶⁾	$I_{OUT_LILO} = 1\ \text{mA} \ \& \ 350\ \text{mA}$ $V_{IN_LILO} = V_{OUT_DCDC}$ $V_{BATT} = 3.6\text{V}$		4	12	$\mu\text{V}/\text{mA}$
V_{DROP}	Dropout Voltage ⁽⁷⁾	$V_{BATT} = V_{OUT_LILO} + 1.5\text{V}$ (V_{IN_LILO} disconnected from V_{OUT_DCDC}), $I_{OUT} = 350\ \text{mA}$		50	80	mV
$I_{Q_VIN_LILO}$	Quiescent Current	$V_{BATT} = V_{IN_LILO} = 3.6\text{V}$		70	90	μA
I_{SC_LILO}	Short Circuit Current Limit	$V_{OUT} = \text{GND} (V_{OUT_LILO} = 0)$	400			mA

- (1) All voltages are with respect to the potential at the GND pin.
 (2) Min and Max limits are guaranteed by design, test, or statistical analysis. Typical (typ.) numbers are not guaranteed, but do represent the most likely norm. Unless otherwise specified, conditions for typ. specifications are: $V_{BATT} = 3.6\text{V}$ and $T_A = 25^\circ\text{C}$.
 (3) The parameters in the electrical characteristic table are tested at $V_{BATT} = 3.6\text{V}$ unless otherwise specified. For performance over the input voltage range refer to datasheet curves.
 (4) The input voltage range recommended for ideal applications performance for the specified output voltages is given below: $V_{BATT} = 2.7\text{V}$ to 5.5V for $1.0\text{V} \leq V_{OUT_DCDC} < 1.8\text{V}$, $V_{BATT} = (V_{OUT_DCDC} + 1\text{V})$ to 5.5V for $1.8\text{V} \leq V_{OUT_DCDC} < 3.6\text{V}$
 (5) V_{IN_LDO} must be ON at all time for biasing internal reference circuits
 (6) To calculate the output voltage from the load regulation specified, use the following equation: $\Delta V_{OUT} = \text{Load Regulation } (\%/ \text{mA}) \times \text{Nominal } V_{OUT} (\text{V}) \times \Delta I_{OUT} (\text{mA})$.
 (7) Dropout voltage is defined as the input to output voltage differential at which the output voltage falls to 100 mV below the nominal output voltage.

Electrical Characteristics

Linear Regulator — LILO (EN_DCDC = EN_LILO = ON - Large NMOS)⁽¹⁾⁽²⁾⁽³⁾⁽⁴⁾ (continued)

Limits in standard typeface are for $T_A = 25^\circ\text{C}$. Limits appearing in **boldface** type apply over the full operating ambient temperature range: $-40^\circ\text{C} \leq T_A = T_J \leq +85^\circ\text{C}$. Unless otherwise noted, specifications apply to the closed loop typical application circuits (linear regulator) with $V_{IN_LDO} = V_{BATT} = 3.6\text{V}^{(5)}$, $V_{IN_LILO} = V_{OUT_DCDC(NOM)}$, $V_{EN(AII)} = V_{BATT}$, $C_{IN_DC} = 4.7\ \mu\text{F}$, $C_{OUT_LILO} = 2.2\ \mu\text{F}$, $C_{IN_LDO} = 1.0\ \mu\text{F}$, $C_{OUT_LDO} = 1.0\ \mu\text{F}$, $C_{OUT_DC} = C_{IN_LILO} = 10\ \mu\text{F}$

Symbol	Parameter	Condition	Limits			Units
			Min	Typ	Max	
LILO (EN_DCDC = OFF, EN_LILO = ON - SMALL NMOS)						
$\Delta V_{OUT_LILO} / V_{OUT_LILO}$	Output Voltage Accuracy, V_{OUT_LILO}	$I_{OUT} = 1\ \text{mA to } 50\ \text{mA}$	1.176		1.224	V
$\Delta V_{OUT_LILO} / \Delta V_{BATT}$	Line Regulation (Small NMOS) ⁽⁸⁾	$V_{IN_LILO} = (V_{OUT_LILO} + 0.3\text{V}) \text{ to } 5.5\text{V}$		0.4	1.5	mV/V
I_{SC_LILO}	Short circuit current	$V_{OUT_LILO} = \text{GND}$	70			mA
$T_{STARTUP}$	Start up time	EN to $0.95V_{OUT}$		70		μS
System Characteristic⁽⁹⁾						
PSRR	Power Supply Rejection Ratio ⁽¹⁰⁾	Signal to $V_{BATT} = 3.6\text{V}$, $V_{IN_LILO} = 1.8\text{V}$ $I_{OUT} = 200\ \text{mA}$, $f = 100\ \text{Hz}$		68		dB
		Signal to $V_{IN_LILO} = 1.8\text{V}$ $I_{OUT} = 200\ \text{mA}$, $f = 1\ \text{kHz}$		60		
e_{N_LILO}	Output Noise voltage ⁽¹⁰⁾	BW = 10 Hz to 100 kHz, $V_{IN_LILO} = 1.8\text{V}$, $I_{OUT} = 200\ \text{mA}$, $V_{IN_LDO} = 3.6\text{V}$		166		μV_{RMS}
ΔV_{OUT_LILO}	Dynamic load transient response	Pulsed load 1 mA - 350 mA $di/dt = 350\ \text{mA}/1\ \mu\text{S}$		+/- 30 ⁽¹¹⁾		mV
ΔV_{IN_LILO}	Dynamic line transient response on V_{BATT}	$V_{BATT} = 3.1\text{V to } 3.7\text{V}$ $V_{IN_LILO} = V_{OUT_DCDC}$ $t_r, t_f = 10\ \mu\text{S}$, $I_{OUT} = 200\ \text{mA}$		+/- 15 ⁽¹¹⁾		mV

(8) To calculate the output voltage from the line regulation specified, use the following equation: $\Delta V_{OUT} = \text{Line Regulation (\%V)} \times \text{Nominal } V_{OUT} (\text{V}) \times \Delta V_{IN} (\text{V})$.

(9) Parameters guaranteed by design.

(10) The noise performance target is applied to PWM mode operation and this does not apply when DCDC converter is operating in PFM mode.

(11) For line and load transient specifications, the + symbol represents an overshoot in the output voltage and the – symbol represents an undershoot in the output voltage. The first value signifies overshoot or undershoot at the rising edge and the second value signifies the overshoot or undershoot at the falling edge.

Electrical Characteristics

Linear Regulator — LDO⁽¹⁾⁽²⁾⁽³⁾⁽⁴⁾

Symbol	Parameter	Conditions	Typical Limit			Units
			Min	Typ	Max	
V_{IN_LDO}	LDO input voltage range		2.7		5.5	V
$\Delta V_{OUT_LDO} / V_{OUT_LDO}$	Output voltage accuracy, V_{OUT_LDO}	$V_{IN} = 3.6\text{V}$ $I_{OUT_LDO} = 1\ \text{mA} \ \& \ 300\ \text{mA}$	2.744	2.8	2.856	V
			2.94	3.0	3.06	
$\Delta V_{OUT_LDO} / \Delta \text{mA}$	Load regulation ⁽⁵⁾	$I_{OUT_LDO} = 1\ \text{mA} \ \& \ 300\ \text{mA}$		8		$\mu\text{V}/\text{mA}$

(1) All voltages are with respect to the potential at the GND pin.

(2) Min and Max limits are guaranteed by design, test, or statistical analysis. Typical (typ.) numbers are not guaranteed, but do represent the most likely norm. Unless otherwise specified, conditions for typ. specifications are: $V_{BATT} = 3.6\text{V}$ and $T_A = 25^\circ\text{C}$.

(3) The parameters in the electrical characteristic table are tested at $V_{BATT} = 3.6\text{V}$ unless otherwise specified. For performance over the input voltage range refer to datasheet curves.

(4) The input voltage range recommended for ideal applications performance for the specified output voltages is given below: $V_{BATT} = 2.7\text{V}$ to 5.5V for $1.0\text{V} \leq V_{OUT_DCDC} < 1.8\text{V}$, $V_{BATT} = (V_{OUT_DCDC} + 1\text{V})$ to 5.5V for $1.8\text{V} \leq V_{OUT_DCDC} < 3.6\text{V}$

(5) To calculate the output voltage from the load regulation specified, use the following equation: $\Delta V_{OUT} = \text{Load Regulation (\%/mA)} \times \text{Nominal } V_{OUT} (\text{V}) \times \Delta I_{OUT} (\text{mA})$.

**Electrical Characteristics
Linear Regulator — LDO⁽¹⁾⁽²⁾⁽³⁾⁽⁴⁾ (continued)**

Symbol	Parameter	Conditions	Typical Limit			Units
			Min	Typ	Max	
$\Delta V_{IN_LDO}/\Delta V_{BATT}$	Line regulation ⁽⁶⁾	$V_{IN_LDO} = (V_{OUT_LDO(NOM)} + 0.3V)$ to 5.5V		0.2		mV/V
V_{DROP}	Dropout voltage ⁽⁷⁾	$I_{OUT} = 300$ mA		120	200	mV
I_Q	Quiescent current	$V_{en} = 0.95V$, $I_{OUT} = 0$ mA		50	80	μ A
I_{SC_LDO}	Short circuit current limit	$V_{OUT} = GND$	350			mA
System Characteristic⁽⁸⁾						
PSRR	Power supply rejection ratio	$EN_DC = EN_LIL0 = GND$ $f = 1$ kHz, $I_{OUT} = 200$ mA		85		dB
		$f = 10$ kHz, $I_{OUT} = 200$ mA Signal to $V_{IN_LDO} = 3.6V$		70		
e_{N_LDO}	Output noise voltage ⁽⁹⁾	$BW = 10$ Hz to 100 kHz, $V_{IN_LDO} = 3.6V$ $I_{OUT} = 200$ mA		6.7		μ V _{RMS}
ΔV_{IN_LDO}	Dynamic line transient response	$V_{IN_LDO} = 3.8V$ to 4.4V $t_r, t_f = 30$ μ s $I_{OUT} = 1$ mA		+/-2 ⁽¹⁰⁾		mV
ΔV_{OUT_LDO}	Dynamic load transient response	Pulsed load 1 mA & 300 mA $t_r, t_f = 10$ μ s		+/-30 ⁽¹⁰⁾		mV

- (6) To calculate the output voltage from the line regulation specified, use the following equation: $\Delta V_{OUT} = \text{Line Regulation (\%/V)} \times \text{Nominal } V_{OUT} \text{ (V)} \times \Delta V_{IN} \text{ (V)}$.
- (7) Dropout voltage is defined as the input to output voltage differential at which the output voltage falls to 100 mV below the nominal output voltage.
- (8) Parameters guaranteed by design.
- (9) The noise performance target is applied to PWM mode operation and this does not apply when DCDC converter is operating in PFM mode.
- (10) For line and load transient specifications, the + symbol represents an overshoot in the output voltage and the – symbol represents an undershoot in the output voltage. The first value signifies overshoot or undershoot at the rising edge and the second value signifies the overshoot or undershoot at the falling edge.

Electrical Characteristics DC-DC Converter⁽¹⁾⁽²⁾⁽³⁾⁽⁴⁾

Symbol	Parameter	Conditions	Limit			Units
			Min	Typ	Max	
V _{FB_DCDC}	Feedback Voltage Accuracy	PWM Mode ⁽⁵⁾	1.746	1.8	1.836	V
V _{REF}	Internal reference voltage			0.5		V
R _{DS(on)(P)}	Pin-Pin Resistance for PFET	V _{BATT} = 3.6V I _{SW} = 100 mA		350	450	mΩ
R _{DS(on)(N)}	Pin-Pin Resistance for NFET	V _{BATT} = 3.6V I _{SW} = 100 mA		150	250	mΩ
I _{Q_AUTO}	Quiescent current for auto mode	No load, device is not switching, FB = HIGH		28	40	μA
I _{LIM}	Switch peak current limit	Open loop	1.035	1.220	1.375	A
F _{OSC}	Internal Oscillator Frequency	PWM Mode	2.4	3	3.4	MHz

- (1) All voltages are with respect to the potential at the GND pin.
- (2) Min and Max limits are guaranteed by design, test, or statistical analysis. Typical (typ.) numbers are not guaranteed, but do represent the most likely norm. Unless otherwise specified, conditions for typ. specifications are: V_{BATT} = 3.6V and T_A = 25°C.
- (3) The parameters in the electrical characteristic table are tested at V_{BATT} = 3.6V unless otherwise specified. For performance over the input voltage range refer to datasheet curves.
- (4) The input voltage range recommended for ideal applications performance for the specified output voltages is given below: V_{BATT} = 2.7V to 5.5V for 1.0V ≤ V_{OUT_DCDC} < 1.8V, V_{BATT} = (V_{OUT_DCDC} + 1V) to 5.5V for 1.8V ≤ V_{OUT_DCDC} < 3.6V
- (5) Electrical Characteristic table reflects open loop data (FB = 0V and current drawn from SW pin ramped up until cycle by cycle current limit is activated). Closed loop current limit is the peak inductor current measured in the application circuit by increasing output current until output voltage drops by 10%.

Electrical Characteristics Global Parameters (DCDC, LILO, & LDO)⁽¹⁾⁽²⁾⁽³⁾⁽⁴⁾

Symbol	Parameter	Conditions	Typical Limit			Units
			Min	Typ	Max	
I _{Q_VBATT}	Quiescent current into V _{BATT}	Full power mode I _{OUT_DCDC} = I _{OUT_LILO} = I _{OUT_LDO} = 0 mA, DC-DC is not switching (FB_DCDC forced higher than V _{OUT_DCDC}) V _{en} = 1.1V,		100	130	μA
I _{Q_GLOBAL}	Shutdown current into V _{BATT}	V _{EN_DCDC} = V _{EN_LILO} = V _{EN_LDO} = 0V		2.5	4	μA
Enable Pins (EN_DCDC, EN_LILO, EN_LDO)						
I _{EN}	Enable pin input current	All EN = 0V		.01	1	μA
V _{IH}	Logic high input		1.1			V
V _{IL}	Logic low input				0.40	V

- (1) All voltages are with respect to the potential at the GND pin.
- (2) Min and Max limits are guaranteed by design, test, or statistical analysis. Typical (typ.) numbers are not guaranteed, but do represent the most likely norm. Unless otherwise specified, conditions for typ. specifications are: V_{BATT} = 3.6V and T_A = 25°C.
- (3) The parameters in the electrical characteristic table are tested at V_{BATT} = 3.6V unless otherwise specified. For performance over the input voltage range refer to datasheet curves.
- (4) The input voltage range recommended for ideal applications performance for the specified output voltages is given below: V_{BATT} = 2.7V to 5.5V for 1.0V ≤ V_{OUT_DCDC} < 1.8V, V_{BATT} = (V_{OUT_DCDC} + 1V) to 5.5V for 1.8V ≤ V_{OUT_DCDC} < 3.6V

Typical Performance Characteristics

Unless otherwise specified, typical application (post regulation), $V_{BATT} = 3.6V$, $T_A = 25^\circ C$, enable pins tied to V_{BATT} , $V_{OUT_DCDC} = 1.8V$, $V_{OUT_LIL0} = 1.2V$, $V_{OUT_LDO} = 2.8V$

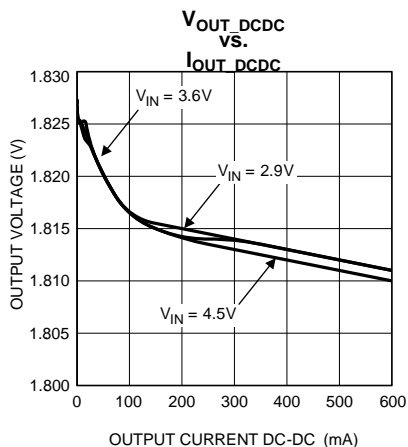

Figure 5.

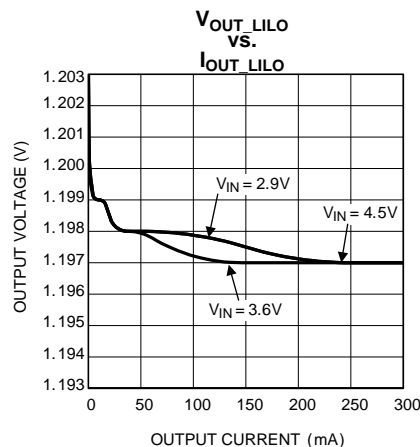

Figure 6.

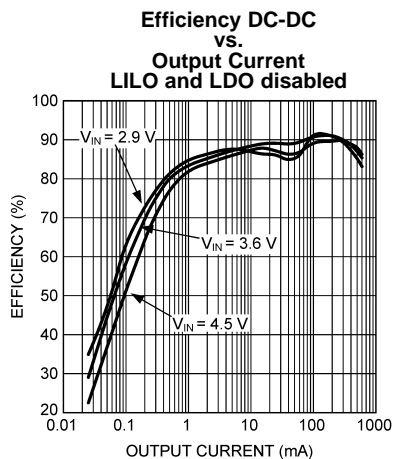

Figure 7.

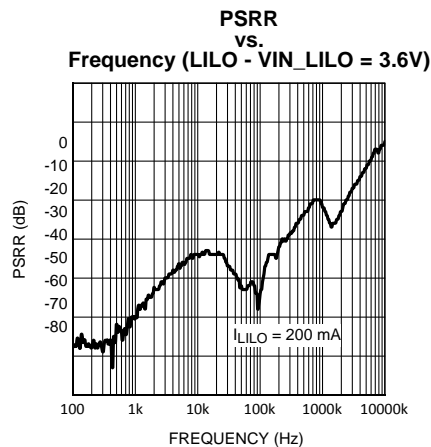

Figure 8.

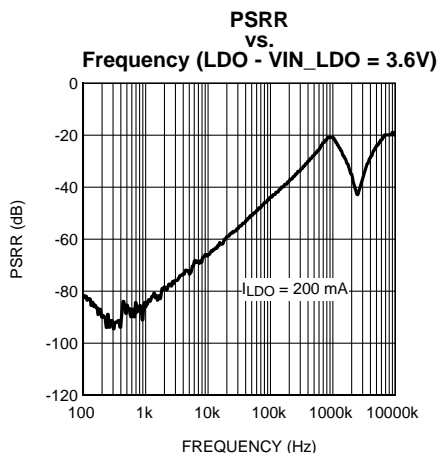

Figure .

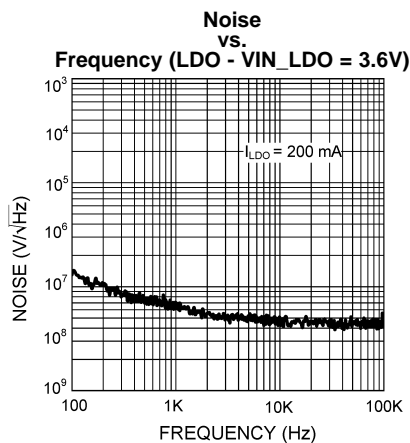

Figure 9.

Typical Performance Characteristics (continued)

Unless otherwise specified, typical application (post regulation), $V_{BATT} = 3.6V$, $T_A = 25^\circ C$, enable pins tied to V_{BATT} , $V_{OUT_DCDC} = 1.8V$, $V_{OUT_L1LO} = 1.2V$, $V_{OUT_LDO} = 2.8V$

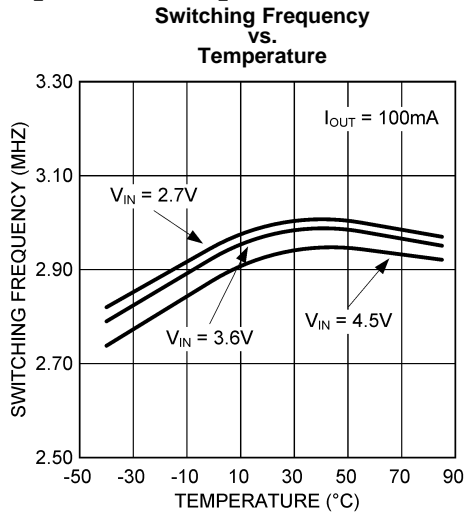

Figure 10.

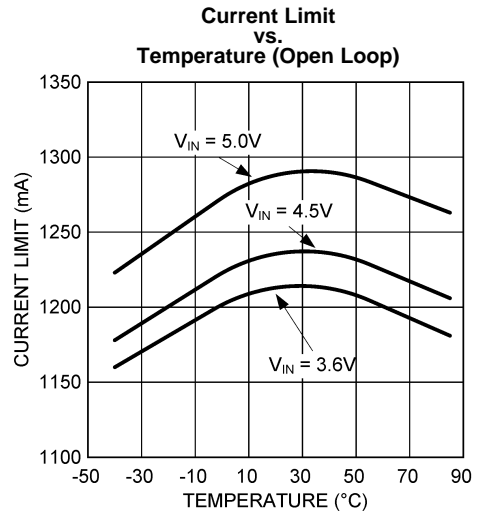

Figure 11.

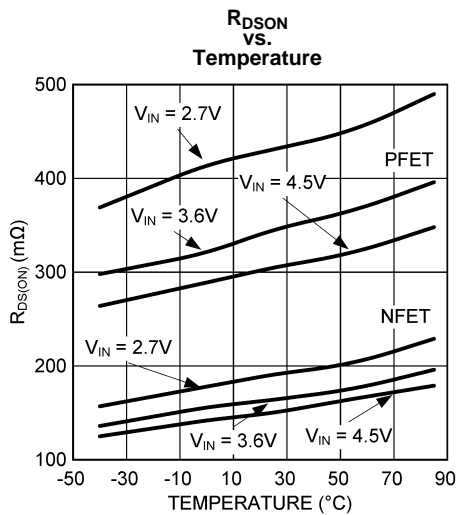

Figure 12.

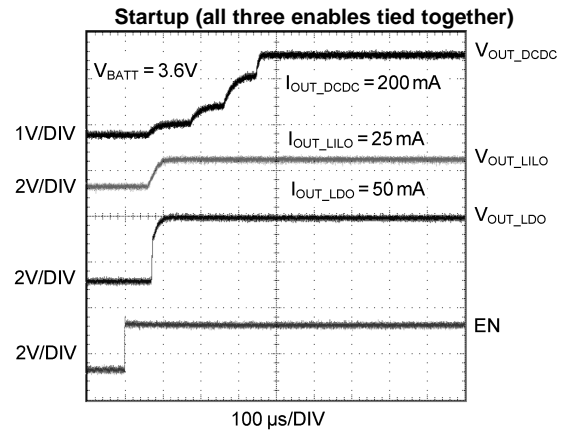

Figure 13.

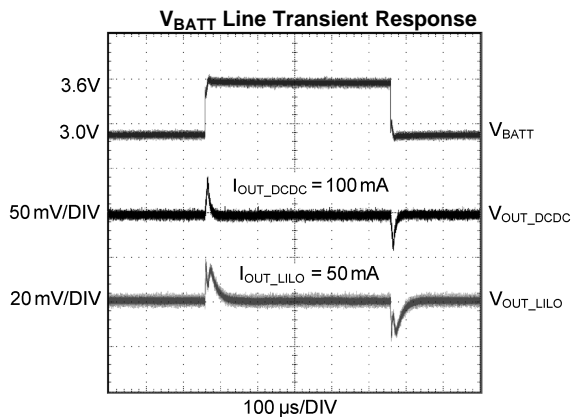

Figure 14.

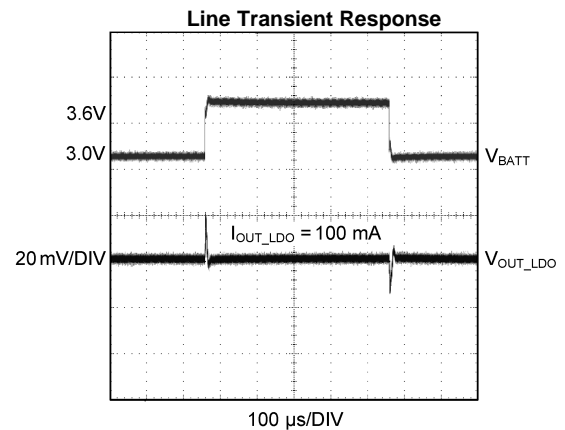

Figure 15.

Typical Performance Characteristics (continued)

Unless otherwise specified, typical application (post regulation), $V_{BATT} = 3.6V$, $T_A = 25^\circ C$, enable pins tied to V_{BATT} , $V_{OUT_DCDC} = 1.8V$, $V_{OUT_LILO} = 1.2V$, $V_{OUT_LDO} = 2.8V$

Load Transient Response DC-DC (PWM Mode: 100mA to 350mA)

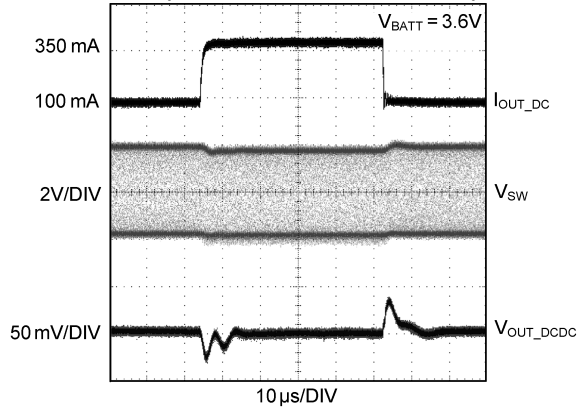

Figure 16.

Load Transient Response DC-DC (PFM Mode: 1mA to 150mA)

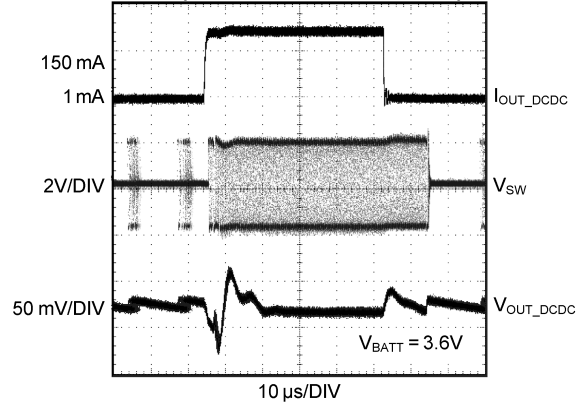

Figure 17.

Load Transient Response LILO 50mA to 250mA

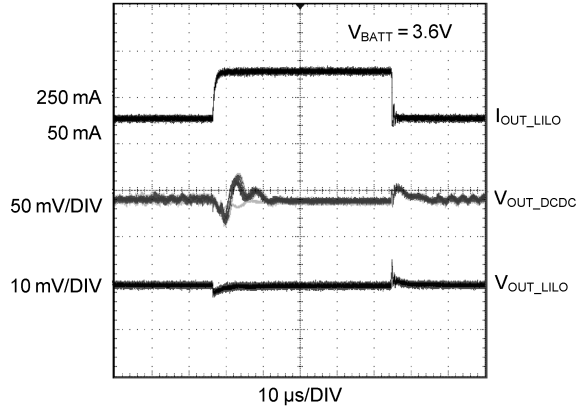

Figure 18.

Load Transient Response LDO 100mA to 250mA

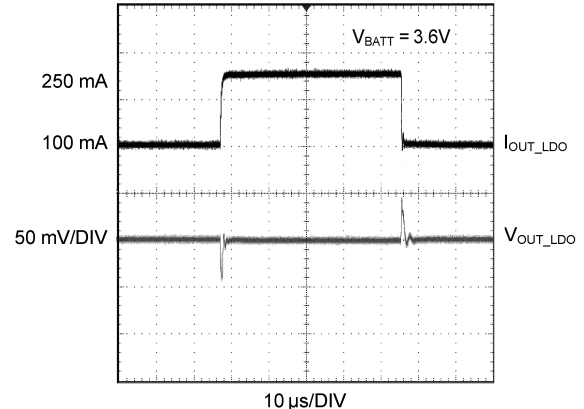

Figure 19.

Operation Description

DEVICE INFORMATION

The LM3686 incorporates a high efficiency synchronous switching step-down DC-DC converter, a very low dropout linear regulator (L1LO), and ultra low noise linear regulator.

The DC-DC converter delivers a constant voltage from a single Li-Ion battery and input voltage rails from 2.7V to 5.5V to portable devices such as cell phones and PDAs. Using a voltage mode architecture with synchronous rectification, it has the ability to deliver up to 600 mA load current (when not powering the L1LO) depending on the input voltage, output voltage, ambient temperature and the inductor chosen.

The linear regulator delivers a constant voltage biased from V_{IN_L1LO} power input typically the output voltage of the DC-DC converter is used (post regulation) with a maximum load current of 350 mA.

The other linear regulator delivers a constant voltage biased from V_{IN_LDO} power input - with a maximum load current of 300 mA.

Three enable pins allow the independent control of the three outputs. Shutdown mode turns off the device, offering the lowest current consumption ($I_{SHUTDOWN} = 2.5 \mu A$ typ).

Besides the shutdown feature, for the DC-DC converter there are two more modes of operation depending on the current required:

- PWM (Pulse Width Modulation), and
- PFM (Pulse Frequency Modulation).

The device operates in PWM mode at load current of approximately 80 mA or higher. Lighter load current cause the device to automatically switch into PFM for reduced current consumption ($I_{Q_VBATT} = 28 \mu A$ typ) and a longer battery life.

Additional features include soft-start, startup mode of the linear regulator, under-voltage protection, current overload protection, and over-temperature protection.

An internal reference generates a 1.8V biasing an internal resistive divider to create a reference voltage range from 0.7V to 1.8V (in 50 mV steps) for the L1LO and the 0.5V reference used for the DC-DC converter. The ultra low noise linear regulator also has internal reference that generates a 1.8V biasing for a internal resistor divider. Thus, creating a reference voltage ranging from 1.5V to 3.3V

The Under-voltage lockout feature enables the device to startup once V_{BATT} has reached 2.65V typically and turns the device off if V_{BATT} drops below 2.41V typically.

Post Regulation Note:

In the case that the DC-DC converter is switched off while the Linear Regulator is still enabled, the L1LO can still support up to 50 mA. The linear regulator L1LO is turned on via a small NMOS device supplied by V_{IN_LDO} . The maximum current is 50 mA when this small NMOS is ON. If higher current > 50 mA is desired the following condition must be done:

- 1) EN_DC = HIGH

When the condition is met, the L1LO transitions to the large NMOS and can support up to 350 mA.

DC-DC CONVERTER OPERATION

During the first part of each switching cycle, the control block in the LM3686 turns on the internal PFET switch. This allows current to flow from the input V_{BATT} through the switch pin SW and the inductor to the output filter capacitor and load. The inductor limits the current to a ramp with a slope of $(V_{BATT} - V_{OUT_DCDC}) / L$, by storing energy in the magnetic field.

During the second part of each cycle, the controller turns the PFET switch off, blocking current flow from the input, and then turns the NFET synchronous rectifier on. The inductor draws current from ground through the NFET to the output filter capacitor and load, which ramps the inductor current down with a slope of $(-V_{OUT_DCDC} / L)$.

The output filter stores charge when the inductor current is high, and releases it when low, smoothing the voltage across the load.

The output voltage is regulated by modulating the PFET switch on time to control the average current sent to the load. The effect is identical to sending a duty-cycle modulated rectangular wave formed by the switch and synchronous rectifier at the SW pin to a low-pass filter formed by the inductor and output filter capacitor. The output voltage is equal to the average voltage at the SW pin.

PWM Operation

During PWM (Pulse Width Modulation) operation the converter operates as a voltage-mode controller with input voltage feed forward. This allows the converter to achieve good load and line regulation. The DC gain of the power stage is proportional to the input voltage. To eliminate this dependency, feed forward inversely proportional to the input voltage is introduced.

While in PWM mode, the output voltage is regulated by switching at a constant frequency and then modulating the energy per cycle to control power to the load. At the beginning of each clock cycle the PFET switch is turned on and the inductor current ramps up until the duty-cycle-comparator trips and the control logic turns off the switch. The current limit comparator can also turn off the switch in case the current limit of the PFET is exceeded. Then the NFET switch is turned on and the inductor current ramps down. The next cycle is initiated by the clock turning off the NFET and turning on the PFET.

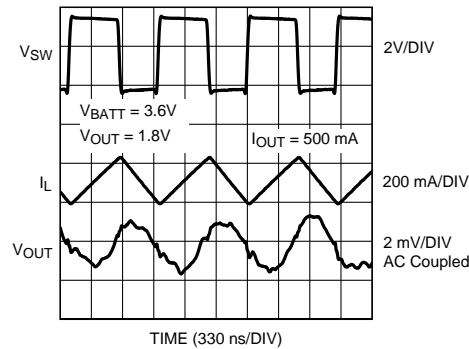

Figure 20. Typical PWM Operation

Internal Synchronous Rectification

While in PWM mode, the DC-DC converter uses an internal NFET as a synchronous rectifier to reduce rectifier forward voltage drop and associated power loss. Synchronous rectification provides a significant improvement in efficiency whenever the output voltage is relatively low compared to the voltage drop across an ordinary rectifier diode.

Current Limiting

A current limit feature allows the LM3686 to protect itself and external components during overload conditions. PWM mode implements current limiting using an internal comparator that trips at 1220mA (typ). If the output is shorted to ground the device enters a timed current limit mode where the NFET is turned on for a longer duration until the inductor current falls below a low threshold. This allows the inductor current more time to decay, thereby preventing runaway.

PFM Operation

At very light load, the DC-DC converter enters PFM mode and operates with reduced switching frequency and supply current to maintain high efficiency. The part automatically transitions into PFM mode when either of two conditions occurs for a duration of 32 or more clock cycles:

- A. The NFET current reaches zero.
- B. The peak PMOS switch current drops below the I_{MODE} level, (typically I_{MODE} < 75 mA + V_{BATT} / 55Ω).

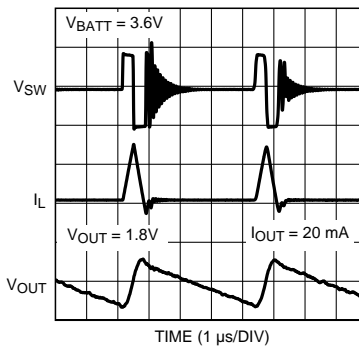

Figure 21. Typical PFM Operation

During PFM operation, the DC-DC converter positions the output voltage slightly higher than the nominal output voltage during PWM operation, allowing additional headroom for voltage drop during a load transient from light to heavy load. The PFM comparators sense the output voltage via the feedback pin and control the switching of the output FETs such that the output voltage ramps between $\sim 0.2\%$ and $\sim 1.8\%$ above the nominal PWM output voltage. If the output voltage is below the 'high' PFM comparator threshold, the PMOS power switch is turned on. It remains on until the output voltage reaches the 'high' PFM threshold or the peak current exceeds the I_{PFM} level set for PFM mode. The typical peak current in PFM mode is: $I_{PFM} = 112 \text{ mA} + V_{BATT} / 20\Omega$.

Once the PMOS power switch is turned off, the NMOS power switch is turned on until the inductor current ramps to zero. When the NMOS zero-current condition is detected, the NMOS power switch is turned off. If the output voltage is below the 'high' PFM comparator threshold (see Figure 22), the PMOS switch is again turned on and the cycle is repeated until the output reaches the desired level. Once the output reaches the 'high' PFM threshold, the NMOS switch is turned on briefly to ramp the inductor current to zero and then both output switches are turned off and the part enters an extremely low power mode. Quiescent supply current during this 'sleep' mode is $28\mu\text{A}$ (typ), which allows the part to achieve high efficiency under extremely light load conditions.

If the load current should increase during PFM mode (see Figure 22) causing the output voltage to fall below the 'low2' PFM threshold, the part will automatically transition into fixed-frequency PWM mode.

When $V_{BATT} = 2.7\text{V}$ the part transitions from PWM to PFM mode at $\sim 35 \text{ mA}$ output current and from PFM to PWM mode at $\sim 95 \text{ mA}$, when $V_{BATT} = 3.6\text{V}$, PWM to PFM transition happens at $\sim 42 \text{ mA}$ and PFM to PWM transition happens at $\sim 115 \text{ mA}$, when $V_{BATT} = 4.5\text{V}$, PWM to PFM transition happens at $\sim 60 \text{ mA}$ and PFM to PWM transition happens at $\sim 135 \text{ mA}$.

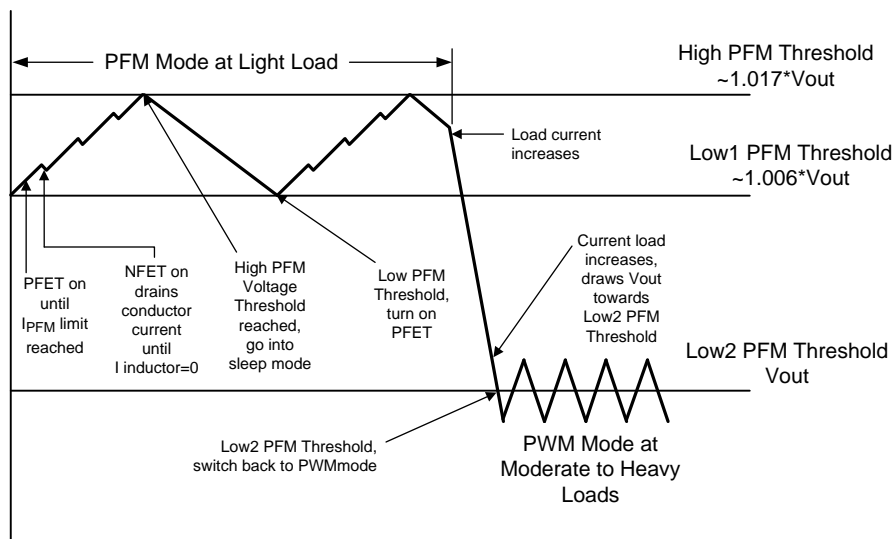

Figure 22. Operation in PFM Mode and Transfer to PWM Mode

Soft Start

The DC-DC converter has a soft-start circuit that limits in-rush current during start-up. During start-up the switch current limit is increased in steps. Soft start is activated only if EN_DCDC goes from logic low to logic high after V_{BATT} reaches 2.7V. Soft start is implemented by increasing switch current limit in steps of 200 mA, 400 mA, 600 mA and 1220 mA (typical switch current limit). The start-up time thereby depends on the output capacitor and load current demanded at start-up. Typical start-up times with a 10 μF output capacitor and 200 mA load is 350 μs and with 1 mA load is 200 μs.

LINEAR REGULATOR OPERATION (LILO)

In the typical post regulation application the power input voltage V_{IN_LILO} for the linear regulator is generated by the DC-DC converter. Using a buck converter to reduce the battery voltage to a lower input voltage for the linear regulator translates to higher efficiency and lower power dissipation.

It's also possible to operate the linear regulator independent of the DC-DC converter output voltage either from V_{IN_LDO}/V_{BATT} or from a different source (V_{IN_LILO}) - (I_{OUT_LILO} = 50 mA max in independent mode).

An input capacitor of 1 μF at V_{IN_LILO} is needed to be added if no other filter or bypass capacitor is present in the V_{IN_LILO} path.

Startup Mode

If V_{IN_LILO} > V_{OUT_LILO(NOM)} + 250 mV the main regulator is active, offering a rated output current of 350 mA and supplied by V_{IN_LILO}. (Large NMOS)

If V_{IN_LILO} < V_{OUT_LILO(NOM)} + 150 mV the startup LILO is active, providing a reduced rated output current of 50 mA typical, supplied by V_{BATT}. (Small NMOS)

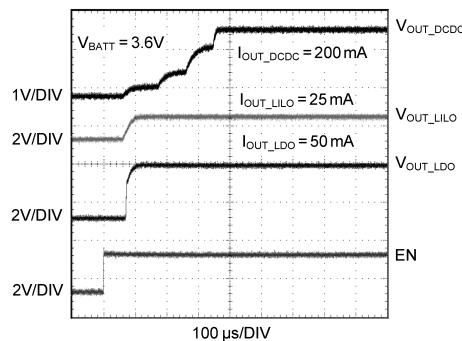

Figure 23. Startup Sequence, V_{EN_DCDC} = V_{EN_LILO} = V_{EN_LDO} = V_{BATT}

Current Limiting (LDO and LILO)

The LM3686 incorporates also a current limit for the LDO and LILO to protect itself and external components during overload conditions at their outputs. In the event of a peak over-current condition at V_{OUT_LDO} or V_{OUT_LILO} the output current through the NFET pass device will be limited.

APPLICATION INFORMATION

Application Selection

It is strongly recommended to select the required components of LM3686 as described within the datasheet. If other components are selected, the device will not perform up to standard and electrical characteristics are not guaranteed.

Inductor Selection

There are two main considerations when choosing an inductor; the inductor should not saturate, and the inductor current ripple should be small enough to achieve the desired output voltage ripple. Different saturation current rating specifications are followed by different manufacturers so attention must be given to details. Saturation current ratings are typically specified at 25°C. However, ratings at the maximum ambient temperature of application should be requested from the manufacturer. **The minimum value of inductance to guarantee good performance is 0.7 µH at I_{LIM} (typ) dc current over the ambient temperature range.** Shielded inductors radiate less noise and should be preferred. There are two methods to choose the inductor saturation current rating.

METHOD 1

The saturation current should be greater than the sum of the maximum load current and the worst case average to peak inductor current. This can be written as:

$$I_{SAT} > I_{OUT_DCDC_MAX} + I_{RIPPLE} \quad (1)$$

where

$$I_{SAT} > I_{OUTMAX} + I_{RIPPLE}$$

$$\text{where } I_{RIPPLE} = \left(\frac{V_{BATT} - V_{OUT}}{2 \times L} \right) \times \left(\frac{V_{OUT}}{V_{BATT}} \right) \times \left(\frac{1}{f} \right)$$

- I_{RIPPLE}: average to peak inductor current
 - I_{OUT_DCDC_MAX}: maximum load current (600 mA)
 - V_{BATT}: maximum input voltage in application
 - L: minimum inductor value including worst case tolerances (30% drop can be considered for method 1)
 - f: minimum switching frequency (2.55 MHz)
- (2)

METHOD 2

A more conservative and recommended approach is to choose an inductor that has a saturation current rating greater than the maximum current limit of 1375 mA.

A 1.0 µH inductor with a saturation current rating of at least 1375 mA is recommended for most applications. The inductor's resistance should be less than 0.3Ω for good efficiency. [Table 1](#) lists suggested inductors and suppliers. For low-cost applications, an unshielded bobbin inductor could be considered. For noise critical applications, a toroidal or shielded- bobbin inductor should be used. A good practice is to lay out the board with overlapping footprints of both types for design flexibility. This allows substitution of a low-noise shielded inductor, in the event that noise from low-cost bobbin models is unacceptable.

Table 1. Suggested Inductors and their Suppliers

Model	Vendor	Dimensions LxWxH (mm)	DCR (max)
BRL2518T1R0M	TAIYO YUDEN	2.5 X 1.8 X 1.2	80
MDT2520CR1R0M	TOKO	2.5 X 2.0 X 1.0	80
KSLI252010AG1R0	HITACHI METALS	2.5 X 2.0 X 1.0	75

External Capacitors

As common with most regulators, the LM3686 requires external capacitors to ensure stable operation. The LM3686 is specifically designed for portable applications requiring minimum board space and the smallest size components. These capacitors must be correctly selected for good performance.

Input Capacitor Selection

C_{IN_DC-DC}

A ceramic input capacitor of 4.7 μF , 6.3V is sufficient for most applications. Place the input capacitor as close as possible to the V_{BATT} pin of the device. A larger value may be used for improved input voltage filtering. Use X7R or X5R types; do not use Y5V. DC bias characteristics of ceramic capacitors must be considered when selecting case sizes like 0805 and 0603. The minimum input capacitance to guarantee good performance is 2.2 μF at 3V dc bias; 1.5 μF at 5V dc bias including tolerances and over ambient temperature range. The input filter capacitor supplies current to the PFET switch of the LM3686 DC-DC converter in the first half of each cycle and reduces voltage ripple imposed on the input power source. A ceramic capacitor's low ESR provides the best noise filtering of the input voltage spikes due to this rapidly changing current. Select a capacitor with sufficient ripple current rating. The input current ripple can be calculated as:

$$I_{RMS} = I_{OUTMAX} \times \sqrt{\frac{V_{OUT}}{V_{BATT}} \times \left(1 - \frac{V_{OUT}}{V_{BATT}} + \frac{r^2}{12}\right)}$$

$$r = \frac{(V_{BATT} - V_{OUT}) \times V_{OUT}}{L \times f \times I_{OUTMAX} \times V_{BATT}}$$

The worst case is when $V_{BATT} = 2 \times V_{OUT}$ (3)

C_{IN_LILO}

If the LILO is used as post regulation no additional capacitor is needed at V_{IN_LILO} as the output filter capacitor of the DC-DC converter is close by and therefore sufficient.

In case of independent mode use, a 1.0 μF ceramic capacitor is recommended at V_{IN_LILO} if no other filter capacitor is present in the V_{IN_LILO} supply path. This capacitor must be located a distance of not more than 1 cm from the V_{IN_LILO} input pin and returned to QGND.

C_{IN_LDO}

An input capacitor is required for stability. It is recommended to use a 1 μF ceramic capacitor and connected between the V_{IN_LDO} and QGND.

Output Capacitor

C_{OUT_DCDC}

A ceramic output capacitor of 10 μF , 6.3V is sufficient for most applications. Use X7R or X5R types; do not use Y5V. DC bias characteristics of ceramic capacitors must be considered when selecting case sizes like 0805 and 0603. DC bias characteristics vary from manufacturer to manufacturer and dc bias curves should be requested from them as part of the capacitor selection process.

The minimum output capacitance to guarantee good performance is 5.75 μF at 1.8V DC bias including tolerances and over ambient temperature range. The output filter capacitor smooths out current flow from the inductor to the load, helps maintain a steady output voltage during transient load changes and reduces output voltage ripple. These capacitors must be selected with sufficient capacitance and sufficiently low ESR to perform these functions.

The output voltage ripple is caused by the charging and discharging of the output capacitor and by the R_{ESR} and can be calculated as:

Voltage peak-to-peak ripple due to capacitance can be expressed as follow:

$$V_{PP-C} = \frac{I_{RIPPLE}}{4 \times f \times C} \tag{4}$$

Voltage peak-to-peak ripple due to ESR can be expressed as follow:

$$V_{PP-ESR} = (2 \times I_{RIPPLE}) \times R_{ESR} \tag{5}$$

Because these two components are out of phase, the rms (root mean squared) value can be used to get an approximate value of peak-to-peak ripple. The peak-to-peak ripple voltage, rms value can be expressed as follow:

$$V_{PP-RMS} = \sqrt{V_{PP-C}^2 + V_{PP-ESR}^2} \quad (6)$$

Note that the output voltage ripple is dependent on the inductor current ripple and the equivalent series resistance of the output capacitor (R_{ESR}). The R_{ESR} is frequency dependent (as well as temperature dependent); make sure the value used for calculations is at the switching frequency of the part.

C_{OUT_LILO}

The linear regulator is designed specifically to work with very small ceramic output capacitors. A ceramic capacitor (dielectric types X7R, Z5U, or Y5V) in the 2.2 μF range (up to 10 μF) and with an ESR between 3 m Ω to 300 m Ω is suitable as C_{OUT_LIN} in the LM3686 application circuit.

This capacitor must be located a distance of not more than 1cm from the V_{OUT_LILO} pin and returned to a clean analogue ground. It is also possible to use tantalum or film capacitors at the device output, V_{OUT_LILO} but these are not as attractive for reasons of size and cost (see [Table 2](#)).

C_{OUT_LDO}

A ceramic capacitor in the 1 μF to 2.2 μF range, and with ESR between 5 m Ω to 500 m Ω , is suitable for the linear regulator. This output capacitor should be connected no more than 1 cm from V_{OUT_LDO} and QGND

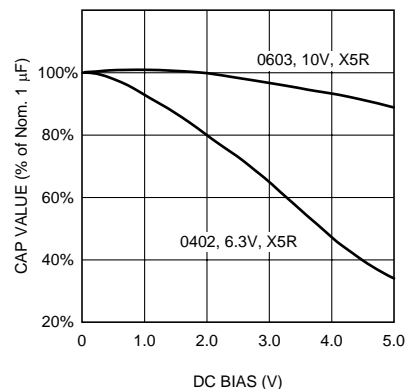

Figure 24. Graph Showing a Typical Variation In Capacitance vs. DC Bias

Table 2. Suggested Capacitors and their Suppliers

Capacitance / μF	Model	Voltage Rating	Vendor	Type	Case Size / Inch (mm)
10.0	C1608X5R0J106K	6.3V	TDK	Ceramic, X5R	0603 (1608)
4.7	C1608X5R0J475	6.3V	TDK	Ceramic, X5R	0603 (1608)
2.2	C1608X5R0J225M	6.3V	TDK	Ceramic, X5R	0603 (1608)
1.0	C1005JB0J105KT	6.3V	TDK	Ceramic, X5R	0402 (1005)

DSBGA Package Assembly And Use

Use of the DSBGA package requires specialized board layout, precision mounting and careful re-flow techniques, as detailed in the TI AN-1112 Application Report ([SNVA009](#)). Refer to the section "Surface Mount Technology (SMD) Assembly Considerations". For best results in assembly, alignment ordinals on the PC board should be used to facilitate placement of the device. The pad style used with DSBGA package must be the NSMD (non-solder mask defined) type. This means that the solder-mask opening is larger than the pad size. This prevents a lip that otherwise forms if the soldermask and pad overlap, from holding the device off the

surface of the board and interfering with mounting. See TI AN-1112 Application Report ([SNVA009](#)) for specific instructions how to do this. The 12-bump package used for LM3686 has 300 micron solder balls and requires 275 micron pads for mounting on the circuit board. The trace to each pad should enter the pad with a 90° entry angle to prevent debris from being caught in deep corners. Initially, the trace to each pad should not exceed 183 micron, for a section approximately 183 micron long or longer, as a thermal relief. Then each trace should neck up or down to its optimal width. The important criteria is symmetry. This ensures the solder bumps on the LM3686 re-flow evenly and that the device solders level to the board. In particular, special attention must be paid to the pads for bumps A1, A2, C1 and B3, because PGND, SGND, V_{BATT} and V_{IN_LIN} are typically connected to large copper planes, inadequate thermal relief can result in late or inadequate re-flow of these bumps. The DSBGA package is optimized for the smallest possible size in applications with red or infrared opaque cases. Because the DSBGA package lacks the plastic encapsulation characteristic of larger devices, it is vulnerable to light. Backside metallization and/or epoxy coating, along with frontside shading by the printed circuit board, reduce this sensitivity. However, the package has exposed die edges. In particular, DSBGA devices are sensitive to light, in the red and infrared range, shining on the package's exposed die edges.

Board Layout Considerations

PC board layout is an important part of DC-DC converter design. Poor board layout can disrupt the performance of a DC-DC converter and surrounding circuitry by contributing to EMI, ground bounce, and resistive voltage loss in the traces. These can send erroneous signals to the DC-DC converter IC, resulting in poor regulation or instability. Good layout for the LM3686 can be implemented by following a few simple design rules below.

1. Place the LM3686, inductor and filter capacitor close together and make the traces short. The traces between these components carry relatively high switching currents and act as antennas. Following this rule reduces radiated noise. Special care must be given to place the input filter capacitor very close to the V_{BATT} and PGND pin. Place the output capacitor of the linear regulator close to the output pin.
2. Arrange the components so that the switching current loops curl in the same direction. During the first half of each cycle, current flows from the input filter capacitor through the LM3686 and inductor to the output filter capacitor and back through ground, forming a current loop. In the second half of each cycle, current is pulled up from ground through the LM3686 by the inductor to the output filter capacitor and then back through ground forming a second current loop. Routing these loops so the current curls in the same direction prevents magnetic field reversal between the two half-cycles and reduces radiated noise.
3. Connect the ground pins of the LM3686 and filter capacitors together using generous component-side copper fill as a pseudo-ground plane. Then, connect this to the ground-plane (if one is used) with several vias. This reduces ground-plane noise by preventing the switching currents from circulating through the ground plane. It also reduces ground bounce at the LM3686 by giving it a low impedance ground connection. Route SGND to the ground-plane by a separate trace.
4. Use wide traces between the power components and for power connections to the DC-DC converter circuit. This reduces voltage errors caused by resistive losses across the traces.
5. Route noise sensitive traces, such as the voltage feedback path (FB_DCDC), away from noisy traces between the power components. The voltage feedback trace must remain close to the LM3686 circuit and should be direct but should be routed opposite to noisy components. This reduces EMI radiated onto the DC-DC converter's own voltage feedback trace. A good approach is to route the feedback trace on another layer and to have a ground plane between the top layer and layer on which the feedback trace is routed.
6. Place noise sensitive circuitry, such as radio IF blocks, away from the DC-DC converter, CMOS digital blocks and other noisy circuitry. Interference with noise sensitive circuitry in the system can be reduced through distance.

In mobile phones, for example, a common practice is to place the DC-DC converter on one corner of the board, arrange the CMOS digital circuitry around it (since this also generates noise), and then place sensitive preamplifiers and IF stages on the diagonally opposing corner. Often, the sensitive circuitry is shielded with a metal plane; power to it is post-regulated to reduce conducted noise, a good field of application for the on-chip low-dropout linear regulator.

PACKAGING INFORMATION

Orderable Device	Status (1)	Package Type	Package Drawing	Pins	Package Qty	Eco Plan (2)	Lead/Ball Finish	MSL Peak Temp (3)	Op Temp (°C)	Top-Side Markings (4)	Samples
LM3686TLE-AADW/NOPB	ACTIVE	DSBGA	YZR	12	250	Green (RoHS & no Sb/Br)	SNAGCU	Level-1-260C-UNLIM	-30 to 85	SUEB	Samples
LM3686TLE-AAED/NOPB	ACTIVE	DSBGA	YZR	12	250	Green (RoHS & no Sb/Br)	SNAGCU	Level-1-260C-UNLIM	-30 to 85	SXTB	Samples
LM3686TLE-AAEF/NOPB	ACTIVE	DSBGA	YZR	12	250	Green (RoHS & no Sb/Br)	SNAGCU	Level-1-260C-UNLIM	-30 to 85	SXZB	Samples
LM3686TLX-AADW/NOPB	ACTIVE	DSBGA	YZR	12	3000	Green (RoHS & no Sb/Br)	SNAGCU	Level-1-260C-UNLIM	-30 to 85	SUEB	Samples
LM3686TLX-AAED/NOPB	ACTIVE	DSBGA	YZR	12	3000	Green (RoHS & no Sb/Br)	SNAGCU	Level-1-260C-UNLIM	-30 to 85	SXTB	Samples
LM3686TLX-AAEF/NOPB	ACTIVE	DSBGA	YZR	12	3000	Green (RoHS & no Sb/Br)	SNAGCU	Level-1-260C-UNLIM	-30 to 85	SXZB	Samples

(1) The marketing status values are defined as follows:

ACTIVE: Product device recommended for new designs.

LIFEBUY: TI has announced that the device will be discontinued, and a lifetime-buy period is in effect.

NRND: Not recommended for new designs. Device is in production to support existing customers, but TI does not recommend using this part in a new design.

PREVIEW: Device has been announced but is not in production. Samples may or may not be available.

OBSOLETE: TI has discontinued the production of the device.

(2) Eco Plan - The planned eco-friendly classification: Pb-Free (RoHS), Pb-Free (RoHS Exempt), or Green (RoHS & no Sb/Br) - please check <http://www.ti.com/productcontent> for the latest availability information and additional product content details.

TBD: The Pb-Free/Green conversion plan has not been defined.

Pb-Free (RoHS): TI's terms "Lead-Free" or "Pb-Free" mean semiconductor products that are compatible with the current RoHS requirements for all 6 substances, including the requirement that lead not exceed 0.1% by weight in homogeneous materials. Where designed to be soldered at high temperatures, TI Pb-Free products are suitable for use in specified lead-free processes.

Pb-Free (RoHS Exempt): This component has a RoHS exemption for either 1) lead-based flip-chip solder bumps used between the die and package, or 2) lead-based die adhesive used between the die and leadframe. The component is otherwise considered Pb-Free (RoHS compatible) as defined above.

Green (RoHS & no Sb/Br): TI defines "Green" to mean Pb-Free (RoHS compatible), and free of Bromine (Br) and Antimony (Sb) based flame retardants (Br or Sb do not exceed 0.1% by weight in homogeneous material)

(3) MSL, Peak Temp. -- The Moisture Sensitivity Level rating according to the JEDEC industry standard classifications, and peak solder temperature.

(4) Only one of markings shown within the brackets will appear on the physical device.

Important Information and Disclaimer: The information provided on this page represents TI's knowledge and belief as of the date that it is provided. TI bases its knowledge and belief on information provided by third parties, and makes no representation or warranty as to the accuracy of such information. Efforts are underway to better integrate information from third parties. TI has taken and

continues to take reasonable steps to provide representative and accurate information but may not have conducted destructive testing or chemical analysis on incoming materials and chemicals. TI and TI suppliers consider certain information to be proprietary, and thus CAS numbers and other limited information may not be available for release.

In no event shall TI's liability arising out of such information exceed the total purchase price of the TI part(s) at issue in this document sold by TI to Customer on an annual basis.

TAPE AND REEL INFORMATION

QUADRANT ASSIGNMENTS FOR PIN 1 ORIENTATION IN TAPE

*All dimensions are nominal

Device	Package Type	Package Drawing	Pins	SPQ	Reel Diameter (mm)	Reel Width W1 (mm)	A0 (mm)	B0 (mm)	K0 (mm)	P1 (mm)	W (mm)	Pin1 Quadrant
LM3686TLE-AADW/NOPB	DSBGA	YZR	12	250	178.0	8.4	1.83	2.49	0.76	4.0	8.0	Q1
LM3686TLE-AAED/NOPB	DSBGA	YZR	12	250	178.0	8.4	1.83	2.49	0.76	4.0	8.0	Q1
LM3686TLE-AAEF/NOPB	DSBGA	YZR	12	250	178.0	8.4	1.83	2.49	0.76	4.0	8.0	Q1
LM3686TLX-AADW/NOPB	DSBGA	YZR	12	3000	178.0	8.4	1.83	2.49	0.76	4.0	8.0	Q1
LM3686TLX-AAED/NOPB	DSBGA	YZR	12	3000	178.0	8.4	1.83	2.49	0.76	4.0	8.0	Q1
LM3686TLX-AAEF/NOPB	DSBGA	YZR	12	3000	178.0	8.4	1.83	2.49	0.76	4.0	8.0	Q1

TAPE AND REEL BOX DIMENSIONS

*All dimensions are nominal

Device	Package Type	Package Drawing	Pins	SPQ	Length (mm)	Width (mm)	Height (mm)
LM3686TLE-AADW/NOPB	DSBGA	YZR	12	250	203.0	190.0	41.0
LM3686TLE-AAED/NOPB	DSBGA	YZR	12	250	203.0	190.0	41.0
LM3686TLE-AAEF/NOPB	DSBGA	YZR	12	250	203.0	190.0	41.0
LM3686TLX-AADW/NOPB	DSBGA	YZR	12	3000	206.0	191.0	90.0
LM3686TLX-AAED/NOPB	DSBGA	YZR	12	3000	206.0	191.0	90.0
LM3686TLX-AAEF/NOPB	DSBGA	YZR	12	3000	206.0	191.0	90.0

YZR0012

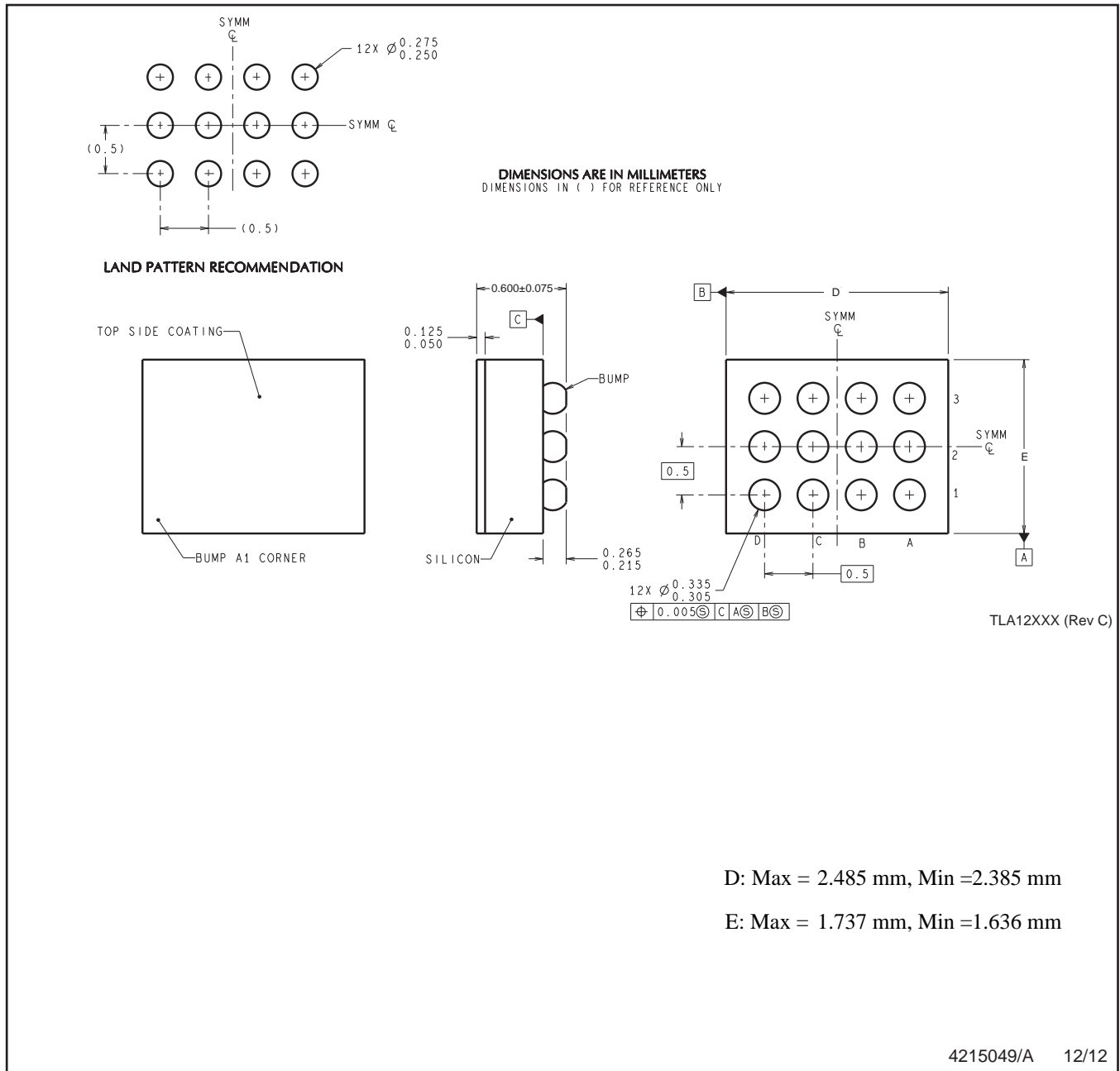

NOTES: A. All linear dimensions are in millimeters. Dimensioning and tolerancing per ASME Y14.5M-1994.
B. This drawing is subject to change without notice.

IMPORTANT NOTICE

Texas Instruments Incorporated and its subsidiaries (TI) reserve the right to make corrections, enhancements, improvements and other changes to its semiconductor products and services per JESD46, latest issue, and to discontinue any product or service per JESD48, latest issue. Buyers should obtain the latest relevant information before placing orders and should verify that such information is current and complete. All semiconductor products (also referred to herein as "components") are sold subject to TI's terms and conditions of sale supplied at the time of order acknowledgment.

TI warrants performance of its components to the specifications applicable at the time of sale, in accordance with the warranty in TI's terms and conditions of sale of semiconductor products. Testing and other quality control techniques are used to the extent TI deems necessary to support this warranty. Except where mandated by applicable law, testing of all parameters of each component is not necessarily performed.

TI assumes no liability for applications assistance or the design of Buyers' products. Buyers are responsible for their products and applications using TI components. To minimize the risks associated with Buyers' products and applications, Buyers should provide adequate design and operating safeguards.

TI does not warrant or represent that any license, either express or implied, is granted under any patent right, copyright, mask work right, or other intellectual property right relating to any combination, machine, or process in which TI components or services are used. Information published by TI regarding third-party products or services does not constitute a license to use such products or services or a warranty or endorsement thereof. Use of such information may require a license from a third party under the patents or other intellectual property of the third party, or a license from TI under the patents or other intellectual property of TI.

Reproduction of significant portions of TI information in TI data books or data sheets is permissible only if reproduction is without alteration and is accompanied by all associated warranties, conditions, limitations, and notices. TI is not responsible or liable for such altered documentation. Information of third parties may be subject to additional restrictions.

Resale of TI components or services with statements different from or beyond the parameters stated by TI for that component or service voids all express and any implied warranties for the associated TI component or service and is an unfair and deceptive business practice. TI is not responsible or liable for any such statements.

Buyer acknowledges and agrees that it is solely responsible for compliance with all legal, regulatory and safety-related requirements concerning its products, and any use of TI components in its applications, notwithstanding any applications-related information or support that may be provided by TI. Buyer represents and agrees that it has all the necessary expertise to create and implement safeguards which anticipate dangerous consequences of failures, monitor failures and their consequences, lessen the likelihood of failures that might cause harm and take appropriate remedial actions. Buyer will fully indemnify TI and its representatives against any damages arising out of the use of any TI components in safety-critical applications.

In some cases, TI components may be promoted specifically to facilitate safety-related applications. With such components, TI's goal is to help enable customers to design and create their own end-product solutions that meet applicable functional safety standards and requirements. Nonetheless, such components are subject to these terms.

No TI components are authorized for use in FDA Class III (or similar life-critical medical equipment) unless authorized officers of the parties have executed a special agreement specifically governing such use.

Only those TI components which TI has specifically designated as military grade or "enhanced plastic" are designed and intended for use in military/aerospace applications or environments. Buyer acknowledges and agrees that any military or aerospace use of TI components which have **not** been so designated is solely at the Buyer's risk, and that Buyer is solely responsible for compliance with all legal and regulatory requirements in connection with such use.

TI has specifically designated certain components as meeting ISO/TS16949 requirements, mainly for automotive use. In any case of use of non-designated products, TI will not be responsible for any failure to meet ISO/TS16949.

Products

Audio	www.ti.com/audio
Amplifiers	amplifier.ti.com
Data Converters	dataconverter.ti.com
DLP® Products	www.dlp.com
DSP	dsp.ti.com
Clocks and Timers	www.ti.com/clocks
Interface	interface.ti.com
Logic	logic.ti.com
Power Mgmt	power.ti.com
Microcontrollers	microcontroller.ti.com
RFID	www.ti-rfid.com
OMAP Applications Processors	www.ti.com/omap
Wireless Connectivity	www.ti.com/wirelessconnectivity

Applications

Automotive and Transportation	www.ti.com/automotive
Communications and Telecom	www.ti.com/communications
Computers and Peripherals	www.ti.com/computers
Consumer Electronics	www.ti.com/consumer-apps
Energy and Lighting	www.ti.com/energy
Industrial	www.ti.com/industrial
Medical	www.ti.com/medical
Security	www.ti.com/security
Space, Avionics and Defense	www.ti.com/space-avionics-defense
Video and Imaging	www.ti.com/video

TI E2E Community

e2e.ti.com