

LM146/LM246/LM346 Programmable Quad Operational Amplifiers

General Description

The LM146 series of quad op amps consists of four independent, high gain, internally compensated, low power, programmable amplifiers. Two external resistors (R_{SET}) allow the user to program the gain bandwidth product, slew rate, supply current, input bias current, input offset current and input noise. For example, the user can trade-off supply current for bandwidth or optimize noise figure for a given source resistance. In a similar way, other amplifier characteristics can be tailored to the application. Except for the two programming pins at the end of the package, the LM146 pin-out is the same as the LM124 and LM148.

Features ($I_{SET} = 10 \mu A$)

- Programmable electrical characteristics
- Battery-powered operation
- Low supply current 350 μA amplifier
- Guaranteed gain bandwidth product 0.8 MHz min
- Large DC voltage gain 120 dB
- Low noise voltage 28 nV/ \sqrt{Hz}
- Wide power supply range $\pm 1.5V$ to $\pm 22V$
- Class AB output stage—no crossover distortion
- Ideal pin out for Biquad active filters
- Input bias currents are temperature compensated

Connection Diagram (Dual-In-Line Package, Top View)

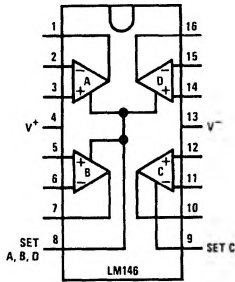

TL/H/5654-1

Order Number LM146J, LM246J, LM346J,
LM346M or LM346N

See NS Package Number J16A, M16A or N16A

PROGRAMMING EQUATIONS

Total Supply Current = 1.4 mA ($I_{SET}/10 \mu A$)

Gain Bandwidth Product = 1 MHz ($I_{SET}/10 \mu A$)

Slew Rate = 0.4/ μs ($I_{SET}/10 \mu A$)

Input Bias Current ≈ 50 nA ($I_{SET}/10 \mu A$)

I_{SET} = Current into pin 8, pin 9 (see schematic diagram)

$$I_{SET} = \frac{V^+ - V^- - 0.6V}{R_{SET}}$$

Schematic Diagram

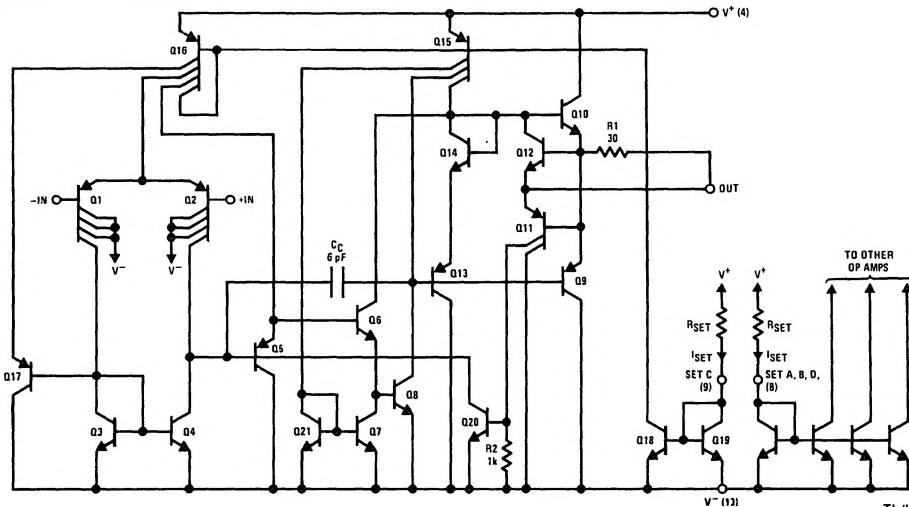

TL/H/5654-2

Absolute Maximum Ratings (Note 1)

If Military/Aerospace specified devices are required, contact the National Semiconductor Sales Office/Distributors for availability and specifications.

(Note 5)

	LM146	LM246	LM346
Supply Voltage	±22V	±18V	±18V
Differential Input Voltage (Note 1)	±30V	±30V	±30V
CM Input Voltage (Note 1)	±15V	±15V	±15V
Power Dissipation (Note 2)	900 mW	500 mW	500 mW
Output Short-Circuit Duration (Note 3)	indefinite	Indefinite	Indefinite
Operating Temperature Range	-55°C to +125°C	-25°C to +85°C	0°C to +70°C
Maximum Junction Temperature	150°C	110°C	100°C
Storage Temperature Range	-65°C to +150°C	-65°C to +150°C	-65°C to +150°C
Lead Temperature (Soldering, 10 seconds)	260°C	260°C	260°C
Thermal Resistance (θ_{jA}), (Note 2)			
Cavity DIP (J) Pd	900 mW	900 mW	900 mW
θ_{jA}	100°C/W	100°C/W	100°C/W
Small Outline (M) θ_{jA}			115°C/W
Molded DIP (N) Pd			500 mW
θ_{jA}			90°C/W
Soldering Information			
Dual-In-Line Package			
Soldering (10 seconds)	+260°C	+260°C	+260°C
Small Outline Package			
Vapor Phase (60 seconds)	+215°C	+215°C	+215°C
Infrared (15 seconds)	+220°C	+220°C	+220°C

See AN-450 "Surface Mounting Methods and Their Effect on Product Reliability" for other methods of soldering surface mount devices.

ESD rating is to be determined.

DC Electrical Characteristics ($V_S = \pm 15V$, $I_{SET} = 10 \mu A$, Note 4)

Parameter	Conditions	LM146			LM246/LM346			Units
		Min	Typ	Max	Min	Typ	Max	
Input Offset Voltage	$V_{CM} = 0V$, $R_S \leq 50\Omega$, $T_A = 25^\circ C$		0.5	5		0.5	6	mV
Input Offset Current	$V_{CM} = 0V$, $T_A = 25^\circ C$		2	20		2	100	nA
Input Bias Current	$V_{CM} = 0V$, $T_A = 25^\circ C$		50	100		50	250	nA
Supply Current (4 Op Amps)	$T_A = 25^\circ C$		1.4	2.0		1.4	2.5	mA
Large Signal Voltage Gain	$R_L = 10 k\Omega$, $\Delta V_{OUT} = \pm 10V$, $T_A = 25^\circ C$	100	1000		50	1000		V/mV
Input CM Range	$T_A = 25^\circ C$	±13.5	±14		±13.5	±14		V
CM Rejection Ratio	$R_S \leq 10 k\Omega$, $T_A = 25^\circ C$	80	100		70	100		dB
Power Supply Rejection Ratio	$R_S \leq 10 k\Omega$, $T_A = 25^\circ C$	80	100		74	100		dB
Output Voltage Swing	$R_L \geq 10 k\Omega$, $T_A = 25^\circ C$	±12	±14		±12	±14		V
Short-Circuit	$T_A = 25^\circ C$	5	20	35	5	20	35	mA
Gain Bandwidth Product	$T_A = 25^\circ C$	0.8	1.2		0.5	1.2		MHz
Phase Margin	$T_A = 25^\circ C$		60			60		Deg
Slew Rate	$T_A = 25^\circ C$		0.4			0.4		V/ μs
Input Noise Voltage	$f = 1 kHz$, $T_A = 25^\circ C$		28			28		nV/ \sqrt{Hz}
Channel Separation	$R_L = 10 k\Omega$, $\Delta V_{OUT} = 0V$ to $\pm 12V$, $T_A = 25^\circ C$		120			120		dB
Input Resistance	$T_A = 25^\circ C$		1.0			1.0		M Ω
Input Capacitance	$T_A = 25^\circ C$		2.0			2.0		pF
Input Offset Voltage	$V_{CM} = 0V$, $R_S \leq 50\Omega$		0.5	6		0.5	7.5	mV
input Offset Current	$V_{CM} = 0V$		2	25		2	100	nA
Input Bias Current	$V_{CM} = 0V$		50	100		50	250	nA
Supply Current (4 Op Amps)			1.7	2.2		1.7	2.5	mA
Large Signal Voltage Gain	$R_L = 10 k\Omega$, $\Delta V_{OUT} = \pm 10V$	50	1000		25	1000		V/mV

DC Electrical Characteristics (Continued) ($V_S = \pm 15V$, $I_{SET} = 1 \mu A$)

Parameter	Conditions	LM146			LM246/LM346			Units
		Min	Typ	Max	Min	Typ	Max	
Input CM Range		± 13.5	± 14		± 13.5	± 14		V
CM Rejection Ratio	$R_S \leq 50\Omega$	70	100		70	100		dB
Power Supply Rejection Ratio	$R_S \leq 50\Omega$	76	100		74	100		dB
Output Voltage Swing	$R_L \geq 10 k\Omega$	± 12	± 14		± 12	± 14		V
Input Offset Voltage	$V_{CM} = 0V$, $R_S \leq 50\Omega$, $T_A = 25^\circ C$		0.5	5		0.5	7	mV
Input Bias Current	$V_{CM} = 0V$, $T_A = 25^\circ C$		7.5	20		7.5	100	nA
Supply Current (4 Op Amps)	$T_A = 25^\circ C$		140	250		140	300	μA
Gain Bandwidth Product	$T_A = 25^\circ C$	80	100		50	100		kHz

DC Electrical Characteristics ($V_S = \pm 1.5V$, $I_{SET} = 10 \mu A$)

Parameter	Conditions	LM146			LM246/LM346			Units
		Min	Typ	Max	Min	Typ	Max	
Input Offset Voltage	$V_{CM} = 0V$, $R_S \leq 50\Omega$, $T_A = 25^\circ C$		0.5	5		0.5	7	mV
Input CM Range	$T_A = 25^\circ C$	± 0.7			± 0.7			V
CM Rejection Ratio	$R_S \leq 50\Omega$, $T_A = 25^\circ C$		80			80		dB
Output Voltage Swing	$R_L \geq 10 k\Omega$, $T_A = 25^\circ C$	± 0.6			± 0.6			V

Note 1: For supply voltages less than $\pm 15V$, the absolute maximum input voltage is equal to the supply voltage.

Note 2: The maximum power dissipation for these devices must be derated at elevated temperatures and is dictated by T_{JMAX} , θ_{JA} , and the ambient temperature, T_A . The maximum available power dissipation at any temperature is $P_d = (T_{JMAX} - T_A) / \theta_{JA}$ or the $25^\circ C$ P_{dMAX} , whichever is less.

Note 3: Any of the amplifier outputs can be shorted to ground indefinitely; however, more than one should not be simultaneously shorted as the maximum junction temperature will be exceeded.

Note 4: These specifications apply over the absolute maximum operating temperature range unless otherwise noted.

Note 5: Refer to RETS146X for LM146J military specifications.

Typical Performance Characteristics

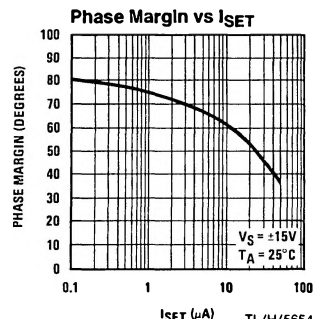
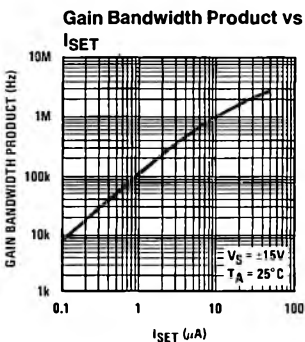
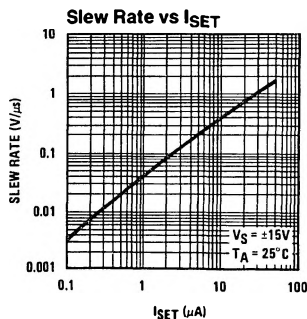
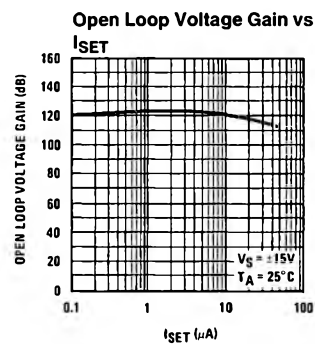
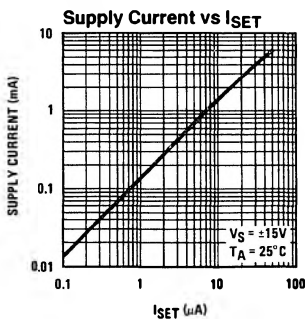
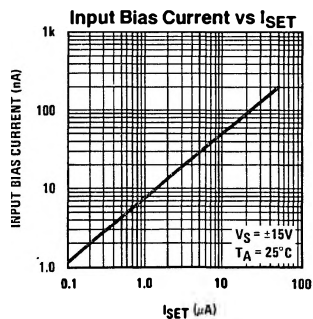

Typical Performance Characteristics (Continued)

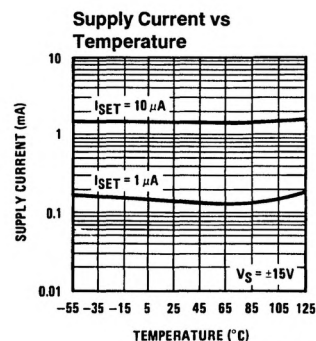
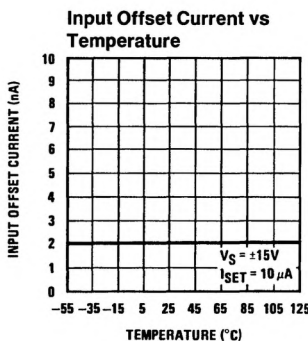
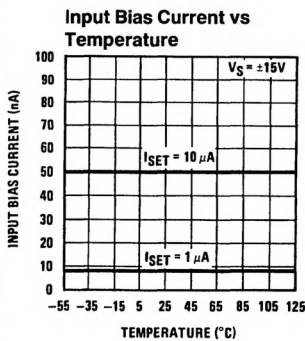
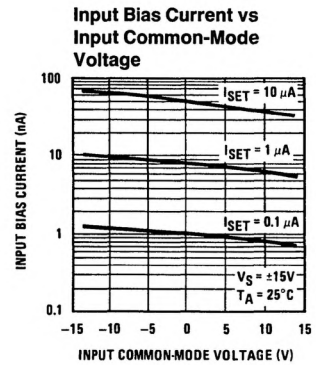
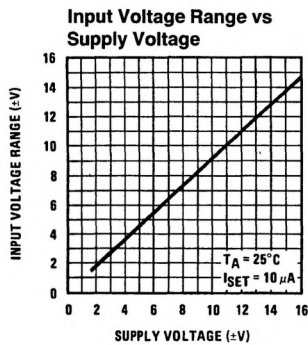
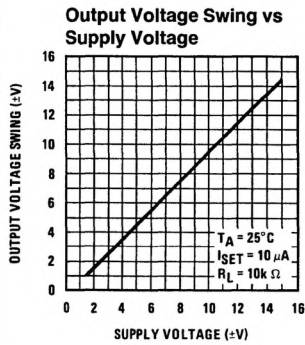
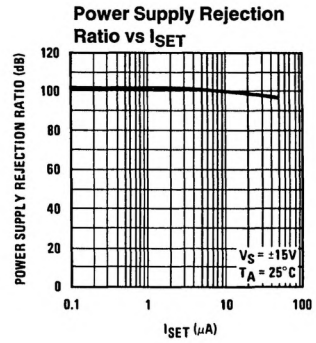
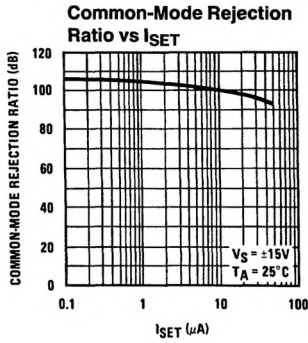
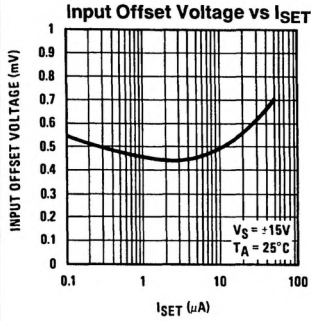

TL/H/5654-4

Typical Performance Characteristics (Continued)

Open Loop Voltage Gain vs Temperature

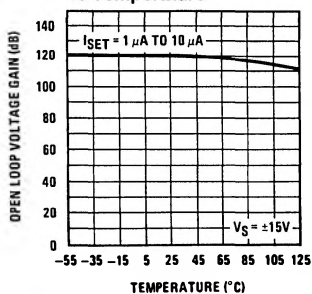

Gain Bandwidth Product vs Temperature

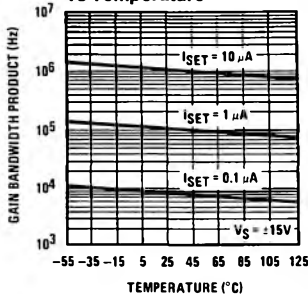

Slew Rate vs Temperature

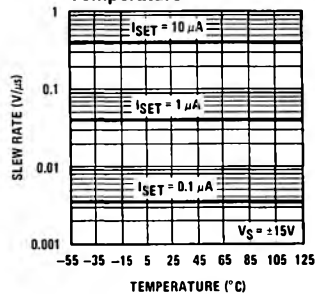

Input Noise Voltage vs Frequency

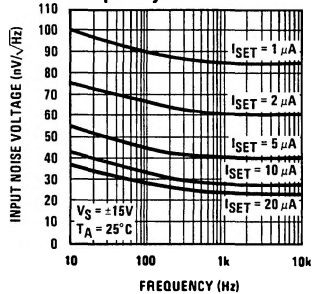

Input Noise Current vs Frequency

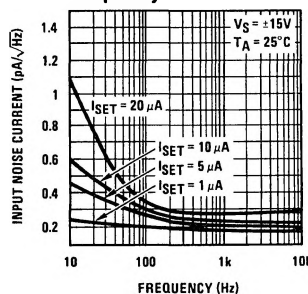

Power Supply Rejection Ratio vs Frequency

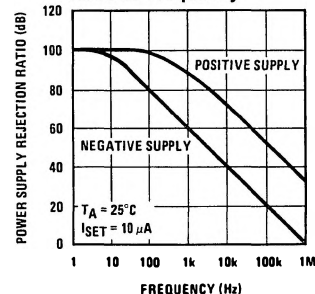

Voltage Follower Pulse Response

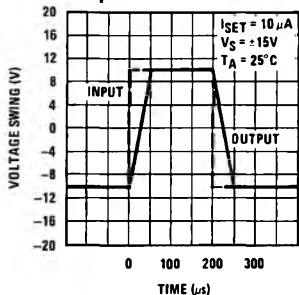

Voltage Follower Transient Response

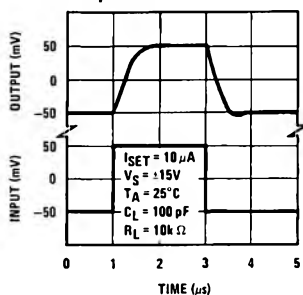

TL/H/5654-5

Transient Response Test Circuit

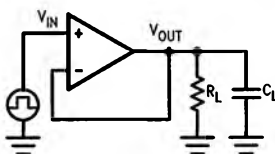

TL/H/5654-6

Application Hints

Avoid reversing the power supply polarity; the device will fail.

Common-Mode Input Voltage: The negative common-mode voltage limit is one diode drop above the negative supply voltage. Exceeding this limit on either input will result in an output phase reversal. The positive common-mode limit is typically 1V below the positive supply voltage. No output phase reversal will occur if this limit is exceeded by either input.

Output Voltage Swing vs I_{SET} : For a desired output voltage swing the value of the minimum load depends on the positive and negative output current capability of the op amp. The maximum available positive output current, (I_{CL+}), of the device increases with I_{SET} whereas the negative output current (I_{CL-}) is independent of I_{SET} . Figure 1 illustrates the above.

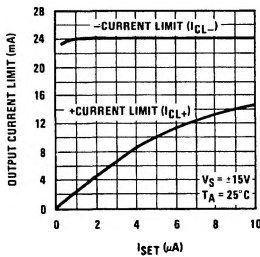

FIGURE 1. Output Current Limit vs I_{SET}

TL/H/5654-7

Input Capacitance: The input capacitance, C_{IN} , of the LM146 is approximately 2 pF; any stray capacitance, C_S , (due to external circuit layout) will add to C_{IN} . When resistive or active feedback is applied, an additional pole is added to the open loop frequency response of the device. For instance with resistive feedback (Figure 2), this pole occurs at $\frac{1}{2\pi} (R_1 || R_2) (C_{IN} + C_S)$. Make sure that this pole occurs at least 2 octaves beyond the expected -3 dB frequency corner of the closed loop gain of the amplifier; if not, place a lead capacitor in the feedback such that the time constant of this capacitor and the resistance it parallels is equal to the $R_1(C_S + C_{IN})$, where R_1 is the input resistance of the circuit.

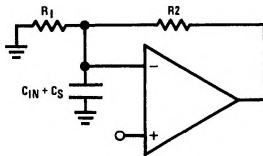

FIGURE 2

TL/H/5654-9

Temperature Effect on the GBW: The GBW (gain bandwidth product), of the LM146 is directly proportional to I_{SET} and inversely proportional to the absolute temperature. When using resistors to set the bias current, I_{SET} , of the device, the GBW product will decrease with increasing temperature. Compensation can be provided by creating an I_{SET} current directly proportional to temperature (see typical applications).

Isolation Between Amplifiers: The LM146 die is isothermally laid out such that crosstalk between *all* 4 amplifiers is in excess of -105 dB (DC). Optimum isolation (better than -110 dB) occurs between amplifiers A and D, B and C; that is, if amplifier A dissipates power on its output stage, amplifier D is the one which will be affected the least, and vice versa. Same argument holds for amplifiers B and C.

LM146 Typical Performance Summary: The LM146 typical behaviour is shown in Figure 3. The device is fully predictable. As the set current, I_{SET} , increases, the speed, the bias current, and the supply current increase while the noise power decreases proportionally and the V_{OS} remains constant. The usable GBW range of the op amp is 10 kHz to 3.5–4 MHz.

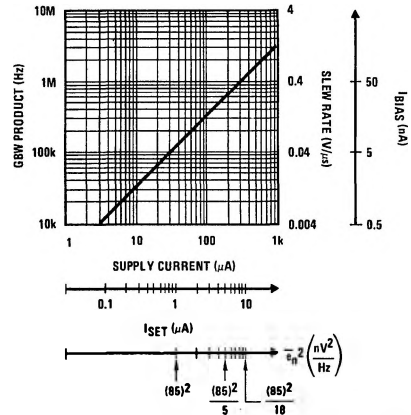

FIGURE 3. LM146 Typical Characteristics

TL/H/5654-8

Low Power Supply Operation: The quad op amp operates down to ± 1.3 V supply. Also, since the internal circuitry is biased through programmable current sources, no degradation of the device speed will occur.

Speed vs Power Consumption: LM146 vs LM4250 (single programmable). Through Figure 4, we observe that the LM146's power consumption has been optimized for GBW products above 200 kHz, whereas the LM4250 will reach a GBW of no more than 300 kHz. For GBW products below 200 kHz, the LM4250 will consume less power.

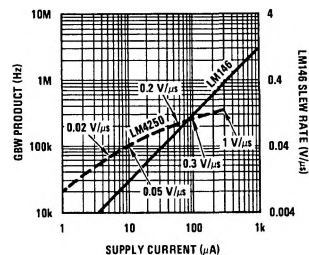
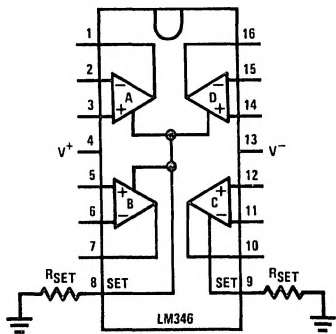

FIGURE 4. LM146 vs LM4250

TL/H/5654-10

Typical Applications

Dual Supply or Negative Supply Biasing



$$I_{SET} \cong \frac{|V^-| - 0.6V}{R_{SET}}$$

Single (Positive) Supply Biasing

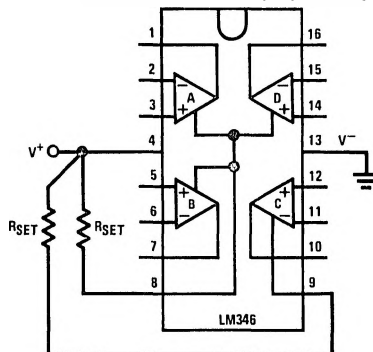

$$I_{SET} \cong \frac{V^+ - 0.6V}{R_{SET}}$$

Current Source Biasing with Temperature Compensation

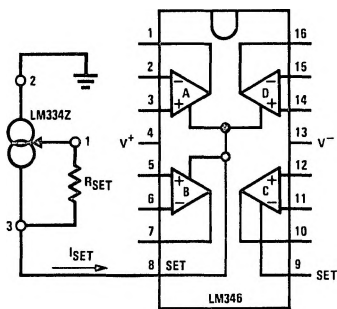

$$I_{SET} = \frac{67.7 \text{ mV}}{R_{SET}}$$

- The LM334 provides an I_{SET} directly proportional to absolute temperature. This cancels the slight GBW product Temperature coefficient of the LM346.

Biasing all 4 Amplifiers with Single Current Source

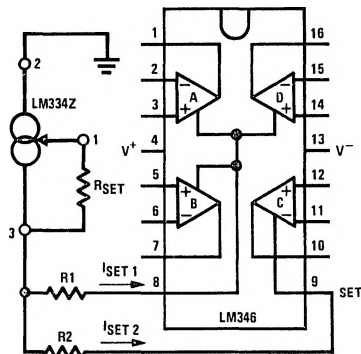

$$\frac{I_{SET1}}{I_{SET2}} = \frac{R2}{R1}, \quad I_{SET1} + I_{SET2} = \frac{67.7 \text{ mV}}{R_{SET}}$$

- For $I_{SET1} = I_{SET2}$ resistors R1 and R2 are not required if a slight error between the 2 set currents can be tolerated. If not, then use $R1 = R2$ to create a 100 mV drop across these resistors.

TL/H/5654-11

Active Filters Applications

Basic (Non-Inverting "State Variable") Active Filter Building Block

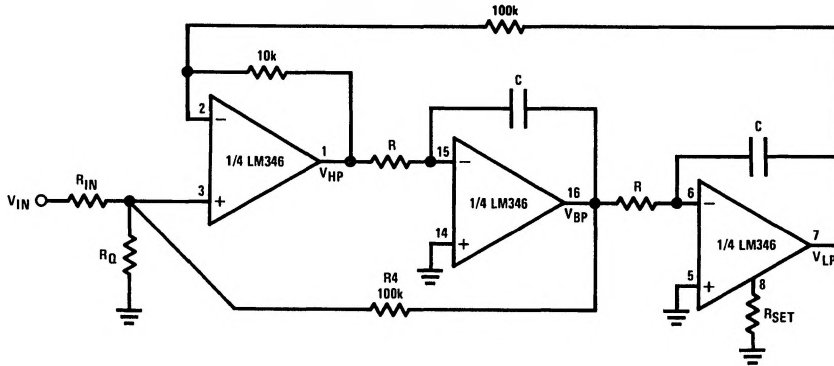

TL/H/5654-12

- The LM146 quad programmable op amp is especially suited for active filters because of their adequate GBW product and low power consumption.

Circuit synthesis equations (for circuit analysis equations, consult with the LM148 data sheet).

Need to know desired: f_0 = center frequency measured at the BP output

Q_0 = quality factor measured at the BP output

H_0 = gain at the output of interest (BP or HP or LP or all of them)

- Relation between different gains: $H_0(BP) = 0.316 \times Q_0 \times H_0(LP)$; $H_0(LP) = 10 \times H_0(HP)$

- $R \times C = \frac{5.033 \times 10^{-2}}{f_0}$ (sec)

- For BP output: $R_Q = \left(\frac{3.478 Q_0 - H_0(BP)}{10^5} - \frac{H_0(BP)}{10^5 \times 3.748 \times Q_0} \right)^{-1}$; $R_{IN} = \left(\frac{3.478 Q_0 - 1}{H_0(BP)} \right) \frac{1}{R_Q + 10^{-5}}$

- For HP output: $R_Q = \frac{1.1 \times 10^5}{3.478 Q_0 (1.1 - H_0(HP)) - H_0(HP)}$; $R_{IN} = \frac{\frac{1.1}{H_0(HP)} - 1}{\frac{1}{R_Q} + 10^{-5}}$

Note. All resistor values are given in ohms.

- For LP output: $R_Q = \frac{11 \times 10^5}{3.478 Q_0 (11 - H_0(LP)) - H_0(LP)}$; $R_{IN} = \frac{\frac{11}{H_0(LP)} - 1}{\frac{1}{R_Q} + 10^{-5}}$

- For BR (notch) output: Use the 4th amplifier of the LM146 to sum the LP and HP outputs of the basic filter.

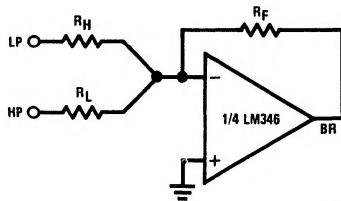

$$\sqrt{\frac{R_H}{R_L}} = 0.316 \frac{f_{notch}}{f_0}$$

TL/H/5654-13

Determine R_F according to the desired gains: $H_0(BR) \left| \begin{matrix} f \ll f_{notch} \\ f \gg f_{notch} \end{matrix} \right. = \frac{R_F}{R_L} H_0(LP), H_0(BR) \left| \begin{matrix} f \ll f_{notch} \\ f \gg f_{notch} \end{matrix} \right. = \frac{R_F}{R_H} H_0(HP)$

- Where to use amplifier C:** Examine the above gain relations and determine the dynamics of the filter. Do not allow slew rate limiting in any output (V_{HP} , V_{BP} , V_{LP}), that is:

$$V_{IN(peak)} < 63.66 \times 10^3 \times \frac{I_{SET}}{10 \mu A} \times \frac{1}{f_0 \times H_0} \text{ (Volts)}$$

If necessary, use amplifier C, biased at higher I_{SET} , where you get the largest output swing.

Deviation from Theoretical Predictions: Due to the finite GBW products of the op amps the f_0 , Q_0 will be slightly different from the theoretical predictions.

$$f_{real} \approx \frac{f_0}{1 + \frac{2f_0}{GBW}}, Q_{real} \approx \frac{Q_0}{1 - \frac{3.2f_0 \times Q_0}{GBW}}$$

Active Filters Applications (Continued)

A Simple-to-Design BP, LP Filter Building Block

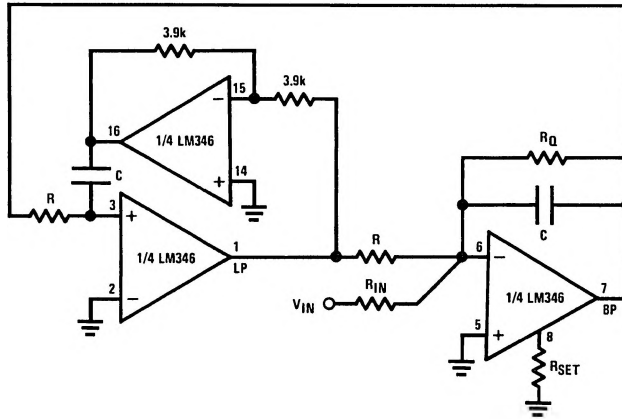

TL/H/5654-14

- If resistive biasing is used to set the LM346 performance, the Q_o of this filter building block is nearly insensitive to the op amp's GBW product temperature drift; it has also better noise performance than the state variable filter.

Circuit Synthesis Equations

$$H_o(BP) = Q_o H_o(LP); R \times C = \frac{0.159}{f_o}; R_Q = Q_o \times R; R_{IN} = \frac{R_Q}{H_o(BP)} = \frac{R}{H_o(LP)}$$

- For the eventual use of amplifier C, see comments on the previous page.

A 3-Amplifier Notch Filter (or Elliptic Filter Building Block)

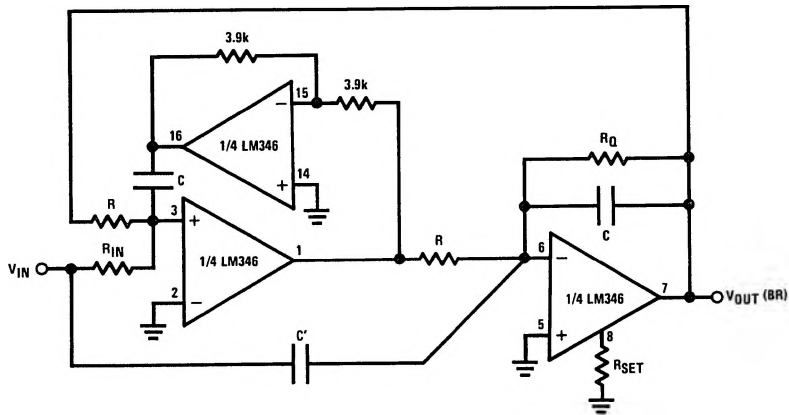

TL/H/5654-15

Circuit Synthesis Equations

$$R \times C = \frac{0.159}{f_o}; R_Q = Q_o \times R; R_{IN} = \frac{0.159 \times f_o}{C' \times f_{notch}^2}$$

$$H_o(BR)|_{f < f_{notch}} = \frac{R}{R_{IN}} H_o(BR)|_{f > f_{notch}} = \frac{C'}{C}$$

- For nothing but a notch output: $R_{IN} = R, C' = C$.

Active Filters Applications (Continued)

Capacitorless Active Filters (Basic Circuit)

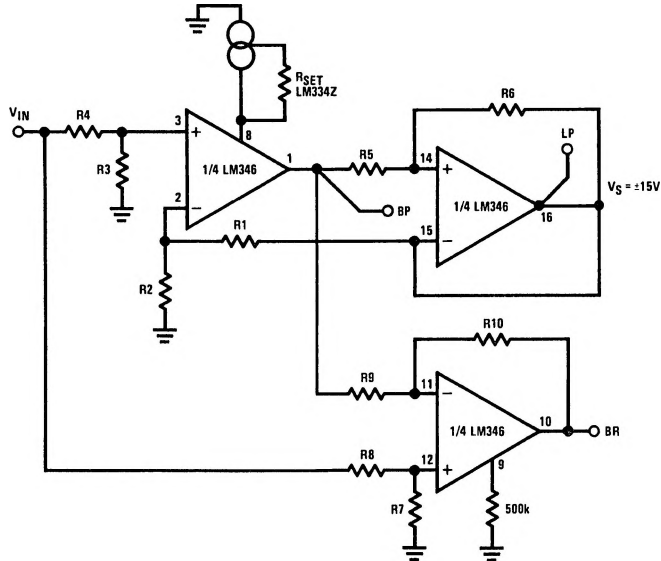

TL/H/5654-16

• This is a BP, LP, BR filter. The filter characteristics are created by using the tunable frequency response of the LM346.

• **Limitations:** $Q_0 < 10$, $f_0 \times Q_0 < 1.5$ MHz, output voltage should not exceed $V_{peak(out)} \leq \frac{63.66 \times 10^3}{f_0} \times \frac{I_{SET}(\mu A)}{10 \mu A}$ (V)

• **Design equations:** $a = \frac{R6 + R5}{R6}$, $b = \frac{R2}{R1 + R2}$, $c = \frac{R3}{R3 + R4}$, $d = \frac{R7}{R8 + R7}$, $e = \frac{R10}{R1 + R10}$, $f_0(BP) = f_0 \sqrt{\frac{b}{a}}$, $H_0(BP) = a \times c$, $H_0(LP) = \frac{c}{d}$, $Q_0 = \sqrt{a \times b}$

$f_0(BR) = f_0(BP)$, $\left(1 - \frac{c}{d}\right) = f_0(BP)$ ($C < 1$) provided that $d = H_0(BP) \times e$, $H_0(BR) = \frac{R10}{R9}$

• **Advantage:** f_0 , Q_0 , H_0 can be independently adjusted; that is, the filter is extremely easy to tune.

• **Tuning procedure (ex. BP tuning)**

1. Pick up a convenient value for b ; ($b < 1$)
2. Adjust Q_0 through $R5$
3. Adjust $H_0(BP)$ through $R4$
4. Adjust f_0 through R_{SET}

A 4th Order Butterworth Low Pass Capacitorless Filter

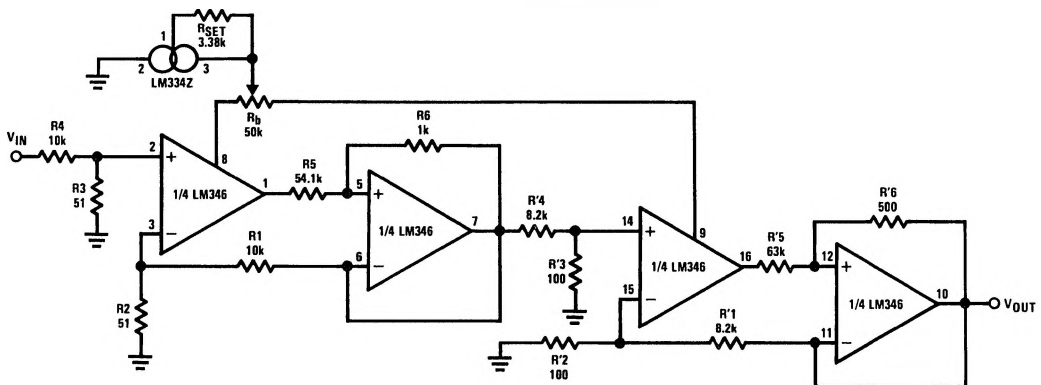

TL/H/5654-17

Ex: $f_0 = 20$ kHz, H_0 (gain of the filter) = 1, $Q_{01} = 0.541$, $Q_{02} = 1.306$.

• Since for this filter the GBW product of all 4 amplifiers has been designed to be the same (~ 1 MHz) only one current source can be used to bias the circuit. Fine tuning can be further accomplished through R_b .

Miscellaneous Applications (Continued)

X10 Micropower Instrumentation Amplifier with Buffered Input Guarding

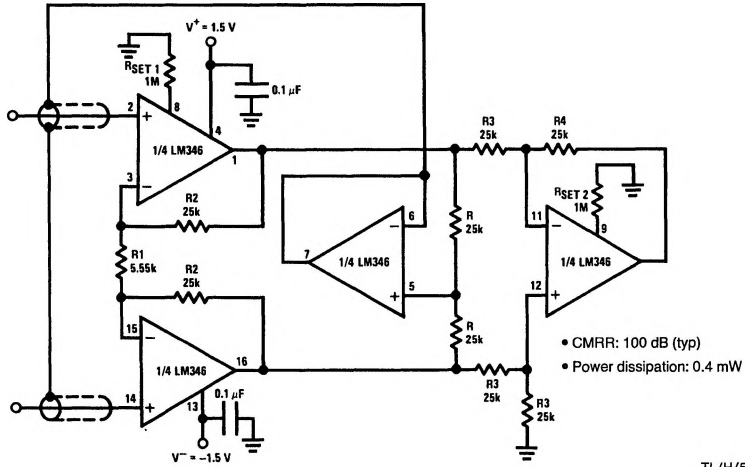

TL/H/5654-19