



LM125/LM325/LM325A, LM126/LM326 Voltage Regulators

General Description

These are dual polarity tracking regulators designed to provide balanced positive and negative output voltages at current up to 100 mA, the devices are set for $\pm 15V$ and $\pm 12V$ outputs respectively. Input voltages up to $\pm 30V$ can be used and there is provision for adjustable current limiting. These devices are available in two package types to accommodate various power requirements and temperature ranges.

Features

- $\pm 15V$ and $\pm 12V$ tracking outputs
- Output current to 100 mA
- Output voltage balanced to within 1% (LM125, LM126, LM325A)
- Line and load regulation of 0.06%
- Internal thermal overload protection
- Standby current drain of 3 mA
- Externally adjustable current limit
- Internal current limit

Schematic and Connection Diagrams

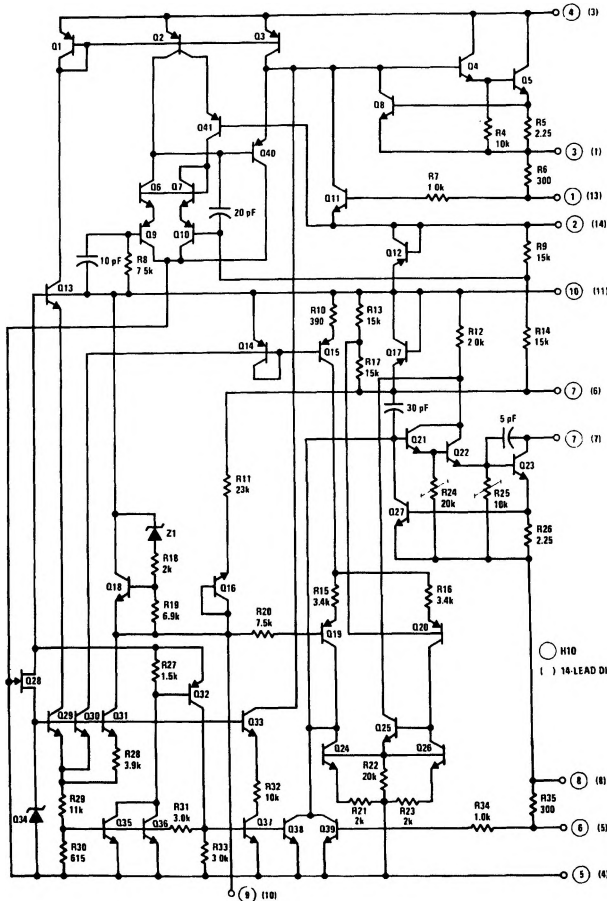

TL/H/7776-1

Dual-In-Line Package

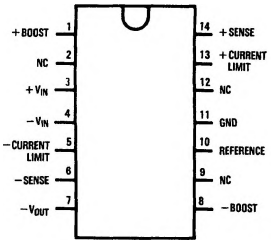

TL/H/7776-2

Top View

Order Number LM325AN,
LM325N or LM326N
See NS Package Number N14A

Metal Can Package

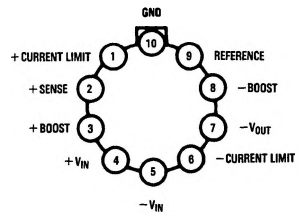

Case connected to $-V_{IN}$ TL/H/7776-3

Top View

Order Number LM125H,
LM325H, LM126H or LM326H
See NS Package Number H10C

Absolute Maximum Ratings

If Military/Aerospace specified devices are required, please contact the National Semiconductor Sales Office/Distributors for availability and specifications. (Note 5)

Input Voltage	±30V
Forced V_{O+} (Min) (Note 1)	-0.5V
Forced V_{O-} (Max) (Note 1)	+0.5V
Power Dissipation (Note 2)	P_{MAX}
Output Short-Circuit Duration (Note 3)	Continuous

Operating Conditions

Operating Free Temperature Range	
LM125	-55°C to +125°C
LM325, LM325A	0°C to +70°C
Storage Temperature Range	-65°C to +150°C
Lead Temperature (Soldering, 10 sec.)	300°C

Electrical Characteristics LM125/LM325/LM325A (Note 2)

Parameter	Conditions	Min	Typ	Max	Units
Output Voltage LM125/LM325A LM325	$T_j = 25^\circ\text{C}$	14.8 14.5	15 15	15.2 15.5	V V
Input-Output Differential		2.0			V
Line Regulation	$V_{IN} = 18\text{V to }30\text{V}$, $I_L = 20\text{ mA}$, $T_j = 25^\circ\text{C}$		2.0	10	mV
Line Regulation Over Temperature Range	$V_{IN} = 18\text{V to }30\text{V}$, $I_L = 20\text{ mA}$,		2.0	20	mV
Load Regulation V_{O+} V_{O-}	$I_L = 0\text{ to }50\text{ mA}$, $V_{IN} = \pm 30\text{V}$, $T_j = 25^\circ\text{C}$		3.0 5.0	10 10	mV mV
Load Regulation Over Temperature Range V_{O+} V_{O-}	$I_L = 0\text{ to }50\text{ mA}$, $V_{IN} = \pm 30\text{V}$		4.0 7.0	20 20	mV mV
Output Voltage Balance LM125, LM325A LM325	$T_j = 25^\circ\text{C}$			±150 ±300	mV mV
Output Voltage Over Temperature Range LM125, LM325A LM325	$P \leq P_{MAX}$, $0 \leq I_O \leq 50\text{ mA}$, $18\text{V} \leq V_{IN} \leq 30$	14.65 14.27		15.35 15.73	V V
Temperature Stability of V_O			±0.3		%
Short Circuit Current Limit	$T_j = 25^\circ\text{C}$		260		mA
Output Noise Voltage	$T_j = 25^\circ\text{C}$, BW = 100 – 10 kHz		150		μVrms
Positive Standby Current	$T_j = 25^\circ\text{C}$		1.75	3.0	mA
Negative Standby Current	$T_j = 25^\circ\text{C}$		3.1	5.0	mA
Long Term Stability			0.2		%/kHr
Thermal Resistance Junction to Case (Note 4) LM125H, LM325H Junction to Ambient Junction to Ambient	(Still Air) (400 Lf/min Air Flow)		20 215 82		°C/W °C/W °C/W
Junction to Ambient LM325AN, LM325N	(Still Air)		90		°C/W

Note 1: That voltage to which the output may be forced without damage to the device.

Note 2: Unless otherwise specified these specifications apply for $T_j = 55^\circ\text{C}$ to $+150^\circ\text{C}$ on LM125, $T_j = 0^\circ\text{C}$ to $+125^\circ\text{C}$ on LM325A, $T_j = 0^\circ\text{C}$ to $+125^\circ\text{C}$ on LM325, $V_{IN} = \pm 20\text{V}$, $I_L = 0\text{ mA}$, $I_{MAX} = 100\text{ mA}$, $P_{MAX} = 2.0\text{W}$ for the H10 Package. $I_{MAX} = 100\text{ mA}$, $I_{MAX} = 100\text{ mA}$, $P_{MAX} = 1.0\text{W}$ for the DIP N Package.

Note 3: If the junction temperature exceeds 150°C , the output short circuit duration is 60 seconds.

Note 4: Without a heat sink, the thermal resistance junction to ambient of the H10 Package is about 155°C/W . With a heat sink, the effective thermal resistance can only approach the junction to case values specified, depending on the efficiency of the sink.

Note 5: Refer to RETS125X drawing for military specification of LM125.

Absolute Maximum Ratings

If Military/Aerospace specified devices are required, please contact the National Semiconductor Sales Office/Distributors for availability and specifications. (Note 5)

Input Voltage	±30V
Forced V_{O+} (Min) (Note 1)	-0.5V
Forced V_{O-} (Max) (Note 1)	+0.5V
Power Dissipation (Note 2)	Internally Limited
Output Short-Circuit Duration (Note 3)	Continuous

Operating Conditions

Operating Free Temperature Range	-55°C to +125°C
LM126	0°C to +70°C
LM326	
Storage Temperature Range	-65°C to +150°C
Lead Temperature (Soldering, 10 sec.)	300°C

Electrical Characteristics LM126/LM326 (Note 2)

Parameter	Conditions	Min	Typ	Max	Units
Output Voltage LM126/LM326	$T_j = 25^\circ\text{C}$	11.8 11.5	12	12.2 12.5	V V
Input-Output Differential		2.0			V
Line Regulation	$V_{IN} = 15\text{V to }30\text{V}$ $I_L = 20\text{ mA}, T_j = 25^\circ\text{C}$		2.0	10	mV
Line Regulation Over Temperature Range	$V_{IN} = 15\text{V to }30\text{V}, I_L = 20\text{ mA}$		2.0	20	mV
Load Regulation V_{O+} V_{O-}	$I_L = 0\text{ to }50\text{ mA}, V_{IN} = \pm 30\text{V},$ $T_j = 25^\circ\text{C}$		3.0 5.0	10 10	mV mV
Load Regulation Over Temperature Range V_{O+} V_{O-}	$I_L = 0\text{ to }50\text{ mA}, V_{IN} = \pm 30\text{V}$		4.0 7.0	20 20	mV mV
Output Voltage Balance LM126, LM326	$T_j = 25^\circ\text{C}$			±125 ±250	mV mV
Output Voltage Over Temperature Range LM126 LM326	$P \leq P_{MAX}, 0 \leq I_O \leq 50\text{ mA},$ $15\text{V} \leq V_{IN} \leq 30$	11.68 11.32		12.32 12.68	V V
Temperature Stability of V_O			±0.3		%
Short Circuit Current Limit	$T_j = 25^\circ\text{C}$		260		mA
Output Noise Voltage	$T_j = 25^\circ\text{C}, \text{BW} = 100 - 10\text{ kHz}$		100		μV_{rms}
Positive Standby Current	$T_j = 25^\circ\text{C}, I_L = 0$		1.75	3.0	mA
Negative Standby Current	$T_j = 25^\circ\text{C}, I_L = 0$		3.1	5.0	mA
Long Term Stability			0.2		%/kHr
Thermal Resistance Junction to Case (Note 4) LM126H, LM326H			20		$^\circ\text{C/W}$
Junction to Ambient	(Still Air)		155		$^\circ\text{C/W}$
Junction to Ambient	(400 Lf/min Air Flow)		62		$^\circ\text{C/W}$
Junction to Ambient LM326N			150		$^\circ\text{C/W}$

Note 1: That voltage to which the output may be forced without damage to the device.

Note 2: Unless otherwise specified these specifications apply for $T_j = 55^\circ\text{C}$ to $+150^\circ\text{C}$ on LM126, $T_j = 0^\circ\text{C}$ to $+125^\circ\text{C}$ on LM326, $V_{IN} = \pm 20\text{V}$, $I_L = 0\text{ mA}$, $I_{MAX} = 100\text{ mA}$, $P_{MAX} = 2.0\text{W}$ for the H10 Package, $I_{MAX} = 100\text{ mA}$, $P_{MAX} = 1.0\text{W}$ for the DIP N Package.

Note 3: If the junction temperature exceeds 150°C , the output short circuit duration is 60 seconds.

Note 4: Without a heat sink, the thermal resistance junction to ambient of the H10 Package is about 155°C/W . With a heat sink, the effective thermal resistance can only approach the junction to case values specified, depending on the efficiency of the sink.

Note 5: Refer to RETS126X drawing for military specification of LM126.

Typical Performance Characteristics

LM125 Load Regulation

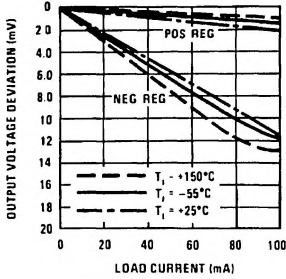

LM126 Load Regulation

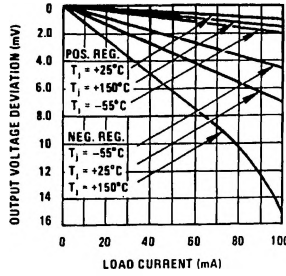

LM125/126 Regulator Dropout Voltage for Positive Regulator

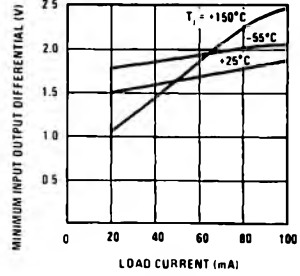

LM125/126 Regulator Dropout Voltage for Negative Regulator

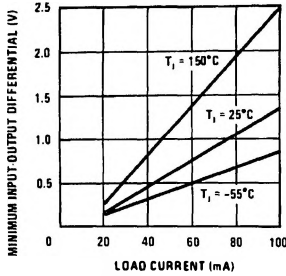

LM125/126 Peak Output Current vs Junction Temperature

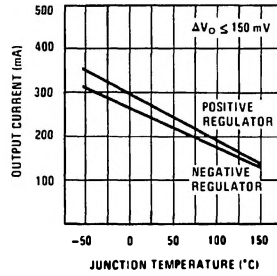

LM125/126 Maximum Average Power Dissipation vs Ambient Temperature

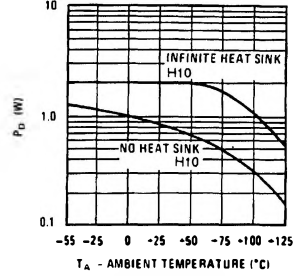

LM325/326 Maximum Average Power Dissipation vs Ambient Temperature

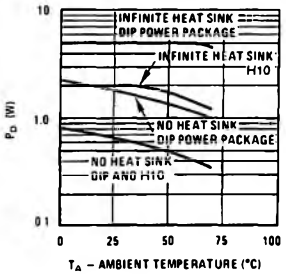

LM125/126 Current Limit Sense Voltage vs Temperature for Negative Regulator

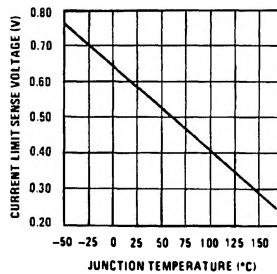

LM125/126 Current Limit Sense Voltage vs Temperature for Positive Regulator

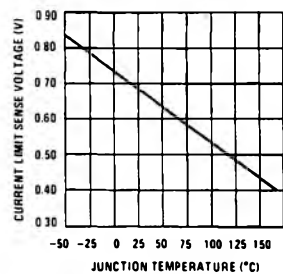

LM125/126 Standby Current Drain

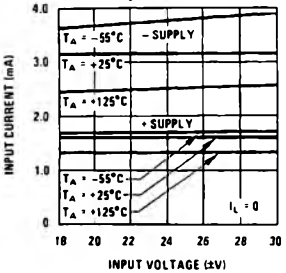

LM125 Load Transient Response for Negative Regulator

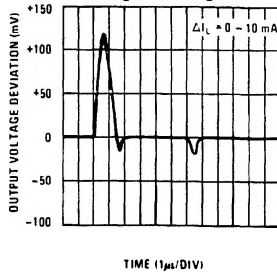

LM126 Load Transient Response

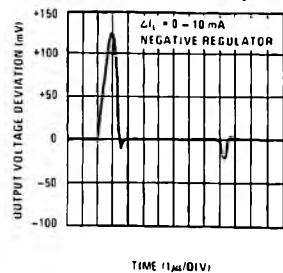

Typical Performance Characteristics (Continued)

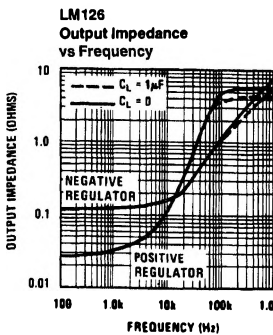
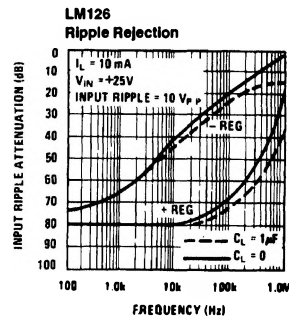
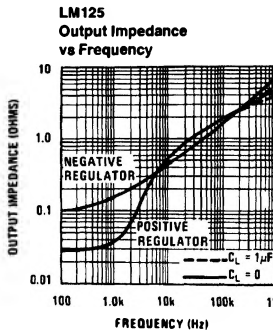
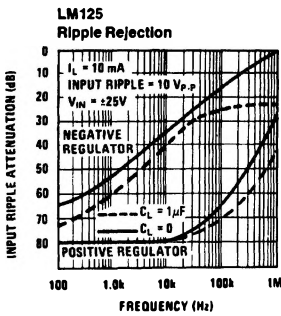
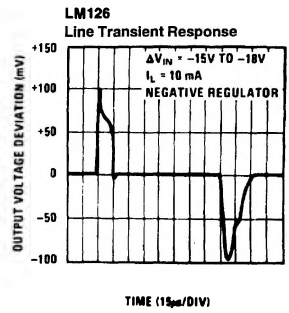
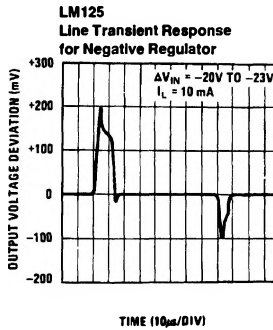
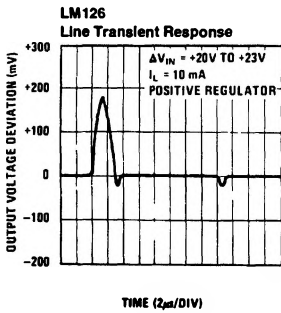
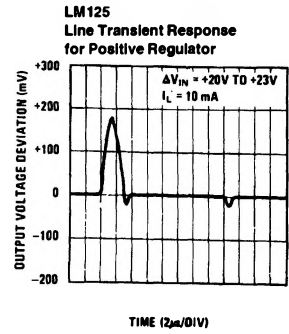
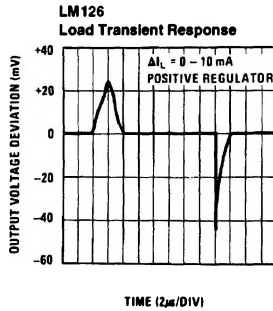
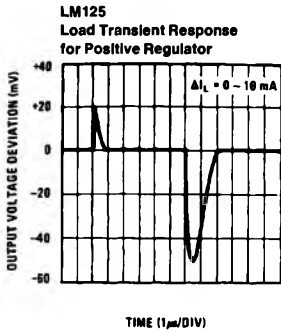

Typical Applications

Basic Regulator†††

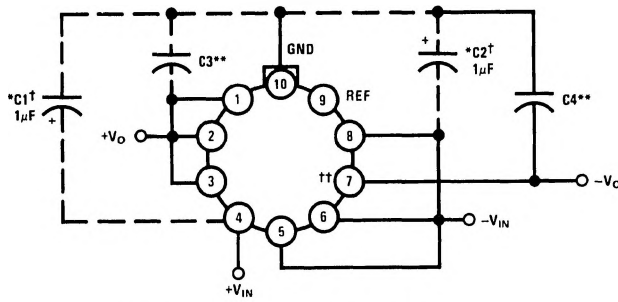

TL/H/7776-6

2.0 Amp Boosted Regulator With Current Limit

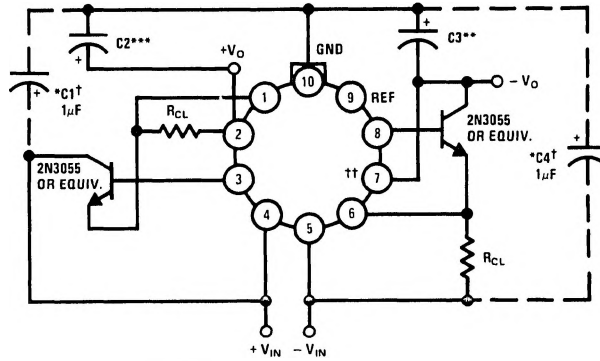

TL/H/7776-7

Note: Metal can (H) packages shown.

$$I_{CL} = \frac{\text{Current Limit Sense Voltage (See Curve)}}{R_{CL}}$$

†Solid tantalum

††Short pins 6 and 7 on dip

††† R_{CL} can be added to the basic regulator between pins 6 and 5, 1 and 2 to reduce current limit.

*Required if regulator is located an appreciable distance from power supply filter.

**Although no capacitor is needed for stability, it does help transient response. (If needed use 1 μ F electrolytic).

***Although no capacitor is needed for stability, it does help transient response. (If needed use 10 μ F electrolytic).

Typical Applications (Continued)

Positive Current Dependent Simultaneous Current Limiting

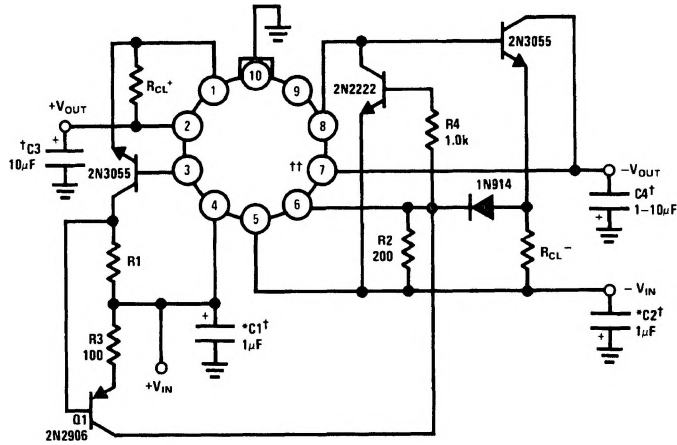

TL/H/7776-8

$$I_{CL}^+ = \frac{\frac{V_{SENSE\ NEG}}{2} + V_{BEQ1}}{R1}$$

$$I_{CL}^+ = \frac{V_{SENSE\ NEG} + V_{DIODE}}{R_{CL}^-}$$

I_{CL}^+ Controls Both Sides of the Regulator.

$$R_{CL}^+ = \frac{V_{SENSE}^+}{1.1 I_{CL}^+}$$

Boosted Regulator With Foldback Current Limit

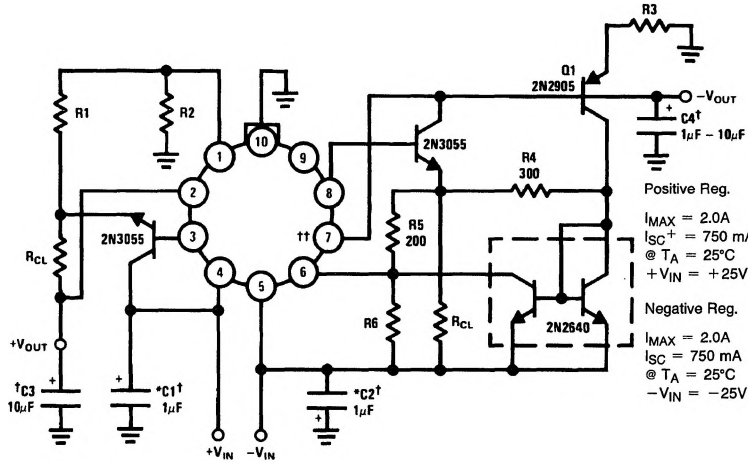

Resistor Values

	125	126
R1	18	20
R2	310	180
R3	2.4k	1.35k
R6	300	290
RCL	0.7	0.9

Positive Reg.
 $I_{MAX} = 2.0A$
 $I_{SC}^+ = 750\ mA$
 @ $T_A = 25^\circ C$
 $+V_{IN} = +25V$

Negative Reg.
 $I_{MAX} = 2.0A$
 $I_{SC}^- = 750\ mA$
 @ $T_A = 25^\circ C$
 $-V_{IN} = -25V$

TL/H/7776-9

Typical Applications (Continued)

Electric Shutdown

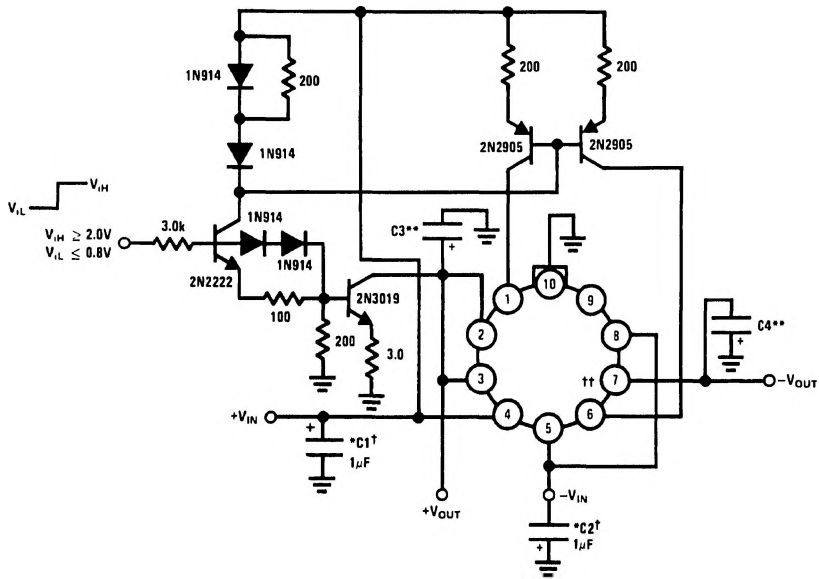

†Solid tantalum

††Short pins 6 and 7 on dip

*Required if regulator is located an appreciable distance from power supply filter.

**Although no capacitor is needed for stability, it does help transient response. (If needed use 1 μF electrolytic).

TL/H/7776-10