

LM120/LM320 Series 3-Terminal Negative Regulators

General Description

The LM120 series are three-terminal negative regulators with a fixed output voltage of $-5V$, $-12V$, and $-15V$, and up to 1.5A load current capability. Where other voltages are required, the LM137 and LM137HV series provide an output voltage range of $-1.2V$ to $-47V$.

The LM120 need only one external component—a compensation capacitor at the output, making them easy to apply. Worst case guarantees on output voltage deviation due to any combination of line, load or temperature variation assure satisfactory system operation.

Exceptional effort has been made to make the LM120 Series immune to overload conditions. The regulators have current limiting which is independent of temperature, combined with thermal overload protection. Internal current limiting protects against momentary faults while thermal shutdown prevents junction temperatures from exceeding safe limits during prolonged overloads.

Although primarily intended for fixed output voltage applications, the LM120 Series may be programmed for higher output voltages with a simple resistive divider. The low quiescent drain current of the devices allows this technique to be used with good regulation.

Features

- Preset output voltage error less than $\pm 3\%$
- Preset current limit
- Internal thermal shutdown
- Operates with input-output voltage differential down to 1V
- Excellent ripple rejection
- Low temperature drift
- Easily adjustable to higher output voltage

LM120 Series Packages and Power Capability

Device	Package	Rated Power Dissipation	Design Load Current
LM120/LM320	TO-3 (K)	20W	1.5A
	TO-39 (H)	2W	0.5A
LM320	TO-220 (T)	15W	1.5A
LM320M	TO-202 (P)	7.5W	0.5A

Typical Applications

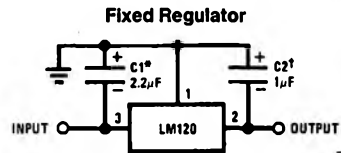
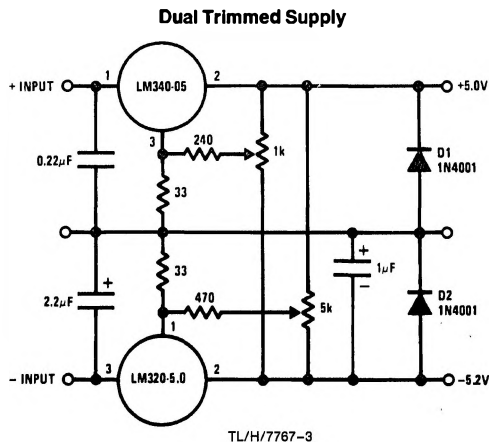

*Required if regulator is separated from filter capacitor by more than 3". For value given, capacitor must be solid tantalum. 25 μF aluminum electrolytic may be substituted.

†Required for stability. For value given, capacitor must be solid tantalum. 25 μF aluminum electrolytic may substituted. Values given may be increased without limit.

For output capacitance in excess of 100 μF , a high current diode from input to output (1N4001, etc.) will protect the regulator from momentary input shorts.

—5 Volt Regulators (Note 3)

Absolute Maximum Ratings

If Military/Aerospace specified devices are required, please contact the National Semiconductor Sales Office/Distributors for availability and specifications. (Note 5)

Power Dissipation Internally Limited
Input Voltage -25V

Input-Output Voltage Differential 25V
Junction Temperatures See Note 1
Storage Temperature Range -65°C to +150°C
Lead Temperature (Soldering, 10 sec.) 300°C
Plastic 260°C

Electrical Characteristics

Parameter	Order Numbers	Metal Can Package						Power Plastic Package						Units				
		LM120K-5.0 (TO-3)		LM120H-5.0 (TO-39)		LM320K-5.0 (TO-3)		LM320H-5.0 (TO-39)		LM320T-5.0 (TO-220)		LM320MP-5.0 (TO-202)						
		Min	Typ	Max	Min	Typ	Max	Min	Typ	Max	Min	Typ	Max					
Design Output Current (I_b) Device Dissipation (P_b)		1.5A 20W		0.5A 2W		1.5A 20W		0.5A 2W		1.5A 15W		0.5A 7.5W						
Conditions (Note 1)																		
Output Voltage	T _J = 25°C, V _{IN} = 10V, I _{LOAD} = 5 mA	-5.1	-5	-4.9	-5.2	-5	-4.8	-5.1	-5	-4.9	-5.2	-5	-4.8	-5.2	-5	-4.8	V	
Line Regulation	T _J = 25°C, I _{LOAD} = 5 mA, V _{MIN} ≤ V _{IN} ≤ V _{MAX}	10	10	25	10	10	40	10	10	25	10	10	40	10	40	40	mV	
Input Voltage		-25	-7	-25	-7	-25	-7	-25	-7	-25	-7	-25	-7	-25	-7.5	-25	V	
Ripple Rejection	f = 120 Hz	54	64	54	64	54	64	54	64	54	64	54	64	54	64	64	dB	
Load Regulation, (Note 2)	T _J = 25°C, V _{IN} = 10V, 5 mA ≤ I _{LOAD} ≤ I _b	50	50	75	60	100	60	100	30	50	50	30	50	100	100	40	100	mV
Output Voltage, (Note 1)	-7.5V ≤ V _{IN} ≤ V _{MAX} , 5 mA ≤ I _{LOAD} ≤ I _b , P ≤ PD	-5.20		-4.80	-5.25	-4.75	-5.20		-4.80	-5.25	-4.75	-5.25		-4.75	-5.25	-5	-4.75	V
Quiescent Current	V _{MIN} ≤ V _{IN} ≤ V _{MAX}		1	2		1	2		1	2		1	2		1	2	2	mA
Quiescent Current Change	T _J = 25°C V _{MIN} ≤ V _{IN} ≤ V _{MAX} 5 mA ≤ I _{LOAD} ≤ I _b		0.1	0.4		0.1	0.4		0.05	0.4		0.05	0.4		0.1	0.4	0.3	mA
Output Noise Voltage	T _A = 25°C, C _L = 1 μF, I _L = 5 mA, V _{IN} = 10V, 10 Hz ≤ f ≤ 100 kHz		150		150		150		150		150		150		150		150	μV
Long Term Stability			5	50		5	50		5	50		5	50		10		10	mV
Thermal Resistance Junction to Case			3			3									4		4	°C/W
Junction to Ambient			35			35									50		50	°C/W

Note 1: This specification applies over -55°C ≤ T_J ≤ +150°C for the LM120 and 0°C ≤ T_J ≤ +125°C for the LM320.

Note 2: Regulation is measured at constant junction temperature. Changes in output voltage due to heating effects must be taken into account separately. To ensure constant junction temperature, low duty cycle, pulse testing is used. The LM120/LM320 series does have low thermal feedback, improving line and load regulation. On all other tests, even though power dissipation is internally limited, electrical specifications apply only up to P_b.

Note 3: For -5V 3 amp regulators, see LM145 data sheet.

Note 4: Thermal resistance of typically 85°C/W (in 400 linear feet air flow), 224°C/W (in static air) junction to ambient, of typically 21°C/W junction to case.

Note 5: Refer to RETS120-5H drawing for LM120H-5.0 or RETS120-5K drawing for LM120-5K military specifications.

— 12 Volt Regulators

Absolute Maximum Ratings

If Military/Aerospace specified devices are required, please contact the National Semiconductor Sales Office/Distributors for availability and specifications. (Note 4)

Input-Output Voltage Differential

Junction Temperatures

Storage Temperature Range

Lead Temperature (Soldering, 10 sec.)

30V

See Note 1

–65°C to +150°C

300°C

Power Dissipation Internally Limited

Input Voltage –35V

Electrical Characteristics

Parameter	Order Numbers	Metal Can Package						Power Plastic Package						Units
		LM120K-12 (TO-3)		LM320K-12 (TO-3)		LM120H-12 (TO-39)		LM320H-12 (TO-39)		LM320T-12 (TO-220)		LM320MP-12 (TO-202)		
		1A 20W	1A 20W	0.2A 2W	0.2A 2W	0.2A 2W	0.2A 2W	1A 15W	1A 15W	0.5A 7.5W	0.5A 7.5W			
Design Output Current (I_O) Device Dissipation (P_D)		Conditions (Note 1)												
Output Voltage		T _J = 25°C, V _{IN} = 17V, I _{LOAD} = 5 mA												
Line Regulation		T _J = 25°C, I _{OLOAD} = 5 mA, V _{MIN} ≤ V _{IN} ≤ V _{MAX}												
Input Voltage		–32												
Ripple Rejection		f = 120 Hz												
Load Regulation, (Note 2)		T _J = 25°C, V _{IN} = 17V, 5 mA ≤ I _{LOAD} ≤ I _D												
Output Voltage, (Note 1)		14.5V ≤ V _{IN} ≤ V _{MAX} , 5 mA ≤ I _{LOAD} ≤ I _D , P ≤ P _D												
Quiescent Current		V _{MIN} ≤ V _{IN} ≤ V _{MAX}												
Quiescent Current Change		T _J = 25°C V _{MIN} ≤ V _{IN} ≤ V _{MAX} 5 mA ≤ I _{LOAD} ≤ I _D												
Output Noise Voltage		T _A = 25°C, C _L = 1 μF, I _O = 5 mA, V _{IN} = 17V, 10 Hz ≤ f ≤ 100 kHz												
Long Term Stability														
Thermal Resistance Junction to Case														
Junction to Ambient														

Note 1: This specification applies over –55°C ≤ T_J ≤ +150°C for the LM120 and 0°C ≤ T_J ≤ +125°C for the LM320.

Note 2: Regulation is measured at constant junction temperature. Changes in output voltage due to heating effects must be taken into account separately. To ensure constant junction temperature, low duty cycle, pulse testing is used. The LM120/LM320 series does have low thermal feedback, improving line and load regulation. On all other tests, even though power dissipation is internally limited, electrical specifications apply only up to P_D.

Note 3: Thermal resistance of typically 95°C/W (in 400 linear feet/min air flow), 224°C/W (in static air) junction to ambient, of typically 21°C/W junction to case.

Note 4: Refer to RETS120H-12 drawing for LM120H-12 or RETS120-12K drawing for LM120K-12 military specifications.

— 15 Volt Regulators

Absolute Maximum Ratings

if Military/Aerospace specified devices are required, please contact the National Semiconductor Sales Office/Distributors for availability and specifications. (Note 4)

Power Dissipation

Internally Limited

Input Voltage

–40V
–35V

Input-Output Voltage Differential

30V

Junction Temperatures

See Note 1

Storage Temperature Range

–65°C to +150°C

Lead Temperature (Soldering, 10 sec.)

300°C

Electrical Characteristics

Parameter	Conditions (Note 1)	Metal Can Package						Power Plastic Package							
		LM120K-15 (TO-3)		LM320K-15 (TO-3)		LM120H-15 (TO-39)		LM320H-15 (TO-39)		LM320T-15 (TO-202)		LM320MP-15 (TO-202)			
		1A Min	20W Typ	1A Min	20W Typ	0.2A 2W Min	0.2A 2W Typ	0.2A 2W Min	0.2A 2W Typ	1A 15W Min	1A 15W Typ	0.5A 7.5W Min	0.5A 7.5W Typ	Max	
Output Voltage	$T_J = 25^\circ\text{C}, V_{IN} = 20\text{V}, I_{LOAD} = 5\text{ mA}$	–15.3	–15	–14.7	–15	–14.6	–15	–14.7	–15	–14.6	–15	–14.5	–15	–14.4	V
Line Regulation	$T_J = 25^\circ\text{C}, I_{LOAD} = 5\text{ mA}, V_{MIN} \leq V_{IN} \leq V_{MAX}$	5	10	20	5	10	5	10	5	20	5	20	5	30	mV
Input Voltage		–35	–17	–35	–17	–35	–17	–35	–17	–35	–17	–35	–17.5	–35	V
Ripple Rejection	$f = 120\text{ Hz}$	56	80	80	56	80	80	56	80	80	56	80	56	80	dB
Load Regulation, (Note 2)	$T_J = 25^\circ\text{C}, V_{IN} = 20\text{V}, 5\text{ mA} \leq I_{LOAD} \leq I_P$	30	80	80	30	80	10	25	10	40	30	80	30	80	mV
Output Voltage, (Note 1)	$17.5\text{V} \leq V_{IN} \leq V_{MAX}, 5\text{ mA} \leq I_{LOAD} \leq I_P, P \leq P_D$	–15.5	–14.5	–15.6	–14.4	–15.5	–14.5	–15.6	–14.4	–15.7	–14.3	–15.7	–14.3	–15.7	V
Quiescent Current	$V_{MIN} \leq V_{IN} \leq V_{MAX}$	2	4	4	2	4	2	4	2	4	2	4	2	4	mA
Quiescent Current Change	$T_J = 25^\circ\text{C}, V_{MIN} \leq V_{IN} \leq V_{MAX}, 5\text{ mA} \leq I_{LOAD} \leq I_P$	0.1	0.4	0.4	0.1	0.4	0.05	0.4	0.05	0.4	0.1	0.4	0.1	0.4	mA
Output Noise Voltage	$T_A = 25^\circ\text{C}, C_L = 1\text{ }\mu\text{F}, I_L = 5\text{ mA}, V_{IN} = 20\text{V}, 10\text{ Hz} \leq f \leq 100\text{ kHz}$	400	400	400	400	400	400	400	400	400	400	400	400	400	μV
Long Term Stability		15	150	150	15	150	15	150	15	150	15	150	30	30	mV
Thermal Resistance Junction to Case		3	3	3	3	3	Note 3	Note 3	Note 3	Note 3	Note 3	Note 3	4	4	$^\circ\text{C}/\text{W}$
Junction to Ambient		35	35	35	35	35	Note 3	Note 3	Note 3	Note 3	Note 3	Note 3	50	50	$^\circ\text{C}/\text{W}$

Note 1: This specification applies over –65°C ≤ T_J ≤ +150°C for the LM120 and 0°C ≤ T_J ≤ +125°C for the LM320.

Note 2: Regulation is measured at constant junction temperature. Changes in output voltage due to heating effects must be taken into account separately. To ensure constant junction temperature, low duty cycle, pulse testing is used. The LM120/LM320 series does have low thermal feedback, improving line and load regulation. On all other tests, even though power dissipation is internally limited, electrical specifications apply only up to P_D.

Note 3: Thermal resistance of typically 95°C/W (in 400 linear feet/min air flow), 22°C/W (in static air) junction to ambient, of typically 21°C/W junction to case.

Note 4: Refer to RETS120-15H drawing for LM120H-15 or RETS120-15K drawing for LM320MP-15 military specifications.

Typical Performance Characteristics

Output Voltage vs Temperature

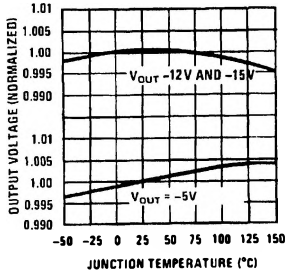

Ripple Rejection (All Types)

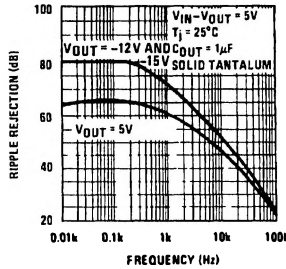

Output Impedance TO-3 and TO-220 Packages

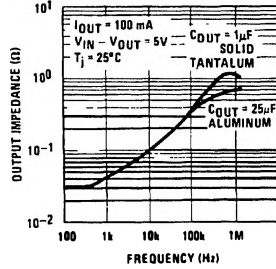

Output Impedance TO-5 and TO-202 Packages

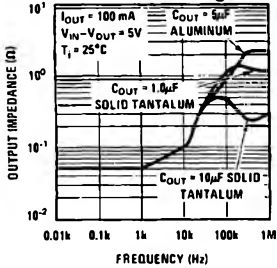

Minimum Input-Output Differential TO-3 and TO-220 Packages

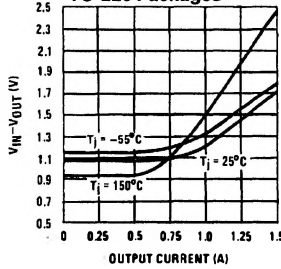

Minimum Input-Output Differential TO-5 and TO-202 Packages

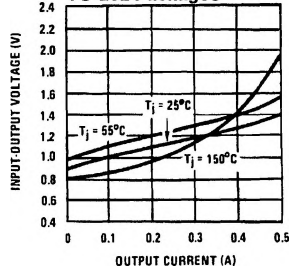

Quiescent Current vs Input Voltage

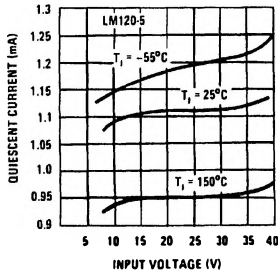

Quiescent Current vs Load Current

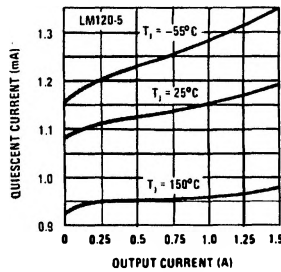

Maximum Average Power Dissipation (TO-3)

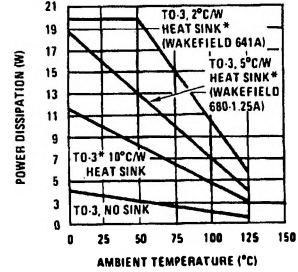

TL/H/7787-4

*These curves for LM120.
Derate 25°C further for LM320.

Typical Performance Characteristics (Continued)

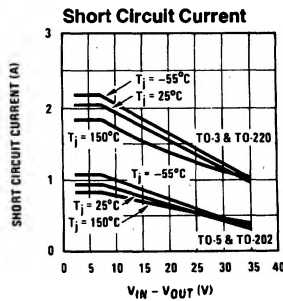
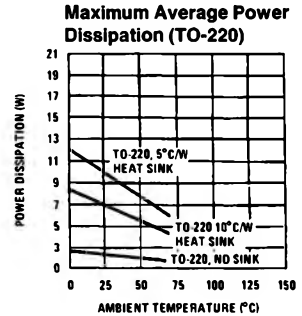
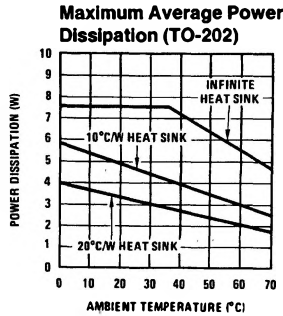
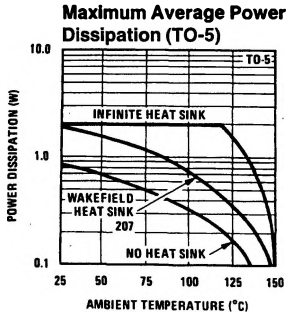

TL/H/7767-5

Typical Applications (Continued)

High Stability 1 Amp Regulator

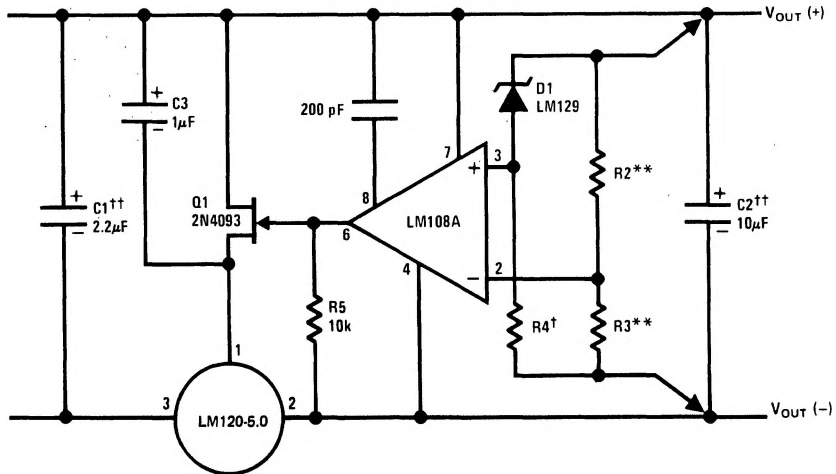

TL/H/7767-6

Load and line regulation — 0.01% temperature stability — 0.2%

†Determines Zener current.

††Solid tantalum.

An LM120-12 or LM120-15 may be used to permit higher input voltages, but the regulated output voltage must be at least -15V when using the LM120-12 and -18V for the LM120-15.

**Select resistors to set output voltage. 2 ppm/°C tracking suggested.

Typical Applications (Continued)

Wide Range Tracking Regulator

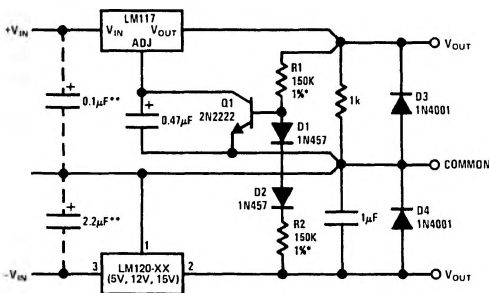

TL/H/7767-7

*Resistor tolerance of R1 and R2 determine matching of (+) and (-) inputs.

**Necessary only if raw supply capacitors are more than 3" from regulators
An LM3086N array may substitute for Q1, D1 and D2 for better stability and tracking. In the array diode transistors Q5 and Q4 (in parallel) make up D2; similarly, Q1 and Q2 become D1 and Q3 replaces the 2N2222.

Variable Output

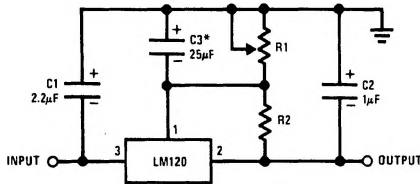

TL/H/7767-9

*Optional. Improves transient response and ripple rejection.

$$V_{OUT} = V_{SET} \frac{R1 + R2}{R2}$$

SELECT R2 AS FOLLOWS:

- LM120-5 - 300Ω
- LM120-12 - 750Ω
- LM120-15 - 1k

Current Source

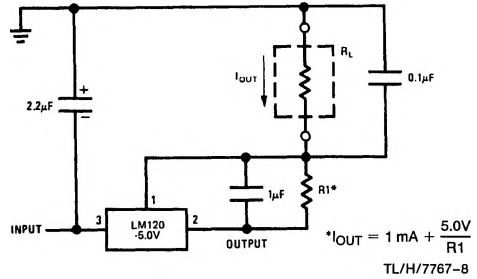

TL/H/7767-8

± 15V, 1 Amp Tracking Regulators

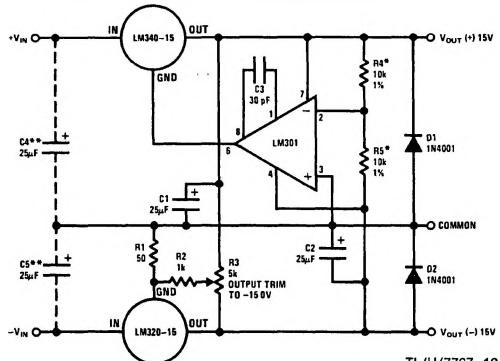

TL/H/7767-12

Performance (Typical)

Load Regulation at $\Delta I_L = 1A$	10 mV	1 mV
Output Ripple, $C_{IN} = 3000 \mu F, I_L = 1A$	100 μV_{rms}	100 μV_{rms}
Temperature Stability	+ 50 mV	+ 50 mV
Output Noise 10 Hz $\leq f \leq 10$ kHz	150 μV_{rms}	150 μV_{rms}

*Resistor tolerance of R4 and R5 determine matching of (+) and (-) outputs.

**Necessary only if raw supply filter capacitors are more than 2" from regulators.

Light Controllers Using Silicon Photo Cells

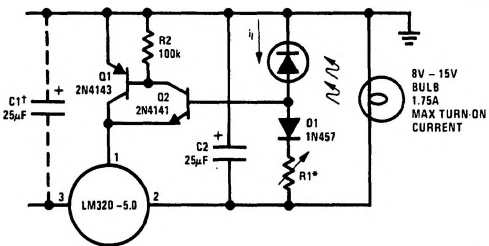

TL/H/7767-10

*Lamp brightness increases until $I_i = 5V/R1$ (I_i can be set as low as 1 μA).

†Necessary only if raw supply filter capacitor is more than 2" from LM320MP.

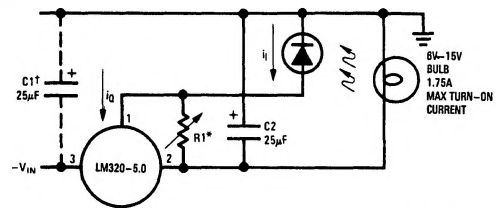

TL/H/7767-11

*Lamp brightness increases until $I_i = I_Q (1 mA) + 5V/R1$.

†Necessary only if raw supply filter capacitor is more than 2" from LM320.

Connection Diagrams

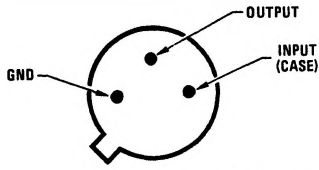

TL/H/7767-13

Metal Can Package TO-39 (H)
 Order Number LM120H-5.0,
 LM120H-12, LM120H-15, LM320H-
 5.0, LM320H-12 or LM320H-15
 See NS Package Number H03A

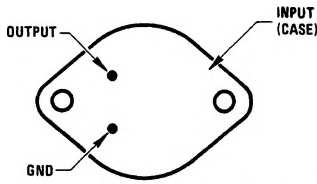

TL/H/7767-14

Steel Metal Can Package TO-3 (K)
 Order Number LM120K-5.0,
 LM120K-12, LM120K-15, LM320K-
 5.0, LM320K-12 or LM320K-15
 See NS Package Number K02A

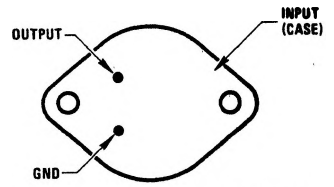

TL/H/7767-15

**Aluminum Metal Can
 Package TO-3 (KC)**
 Order Number LM320KC-5.0,
 LM320KC-12 or LM320KC-15
 See NS Package Number KC02A

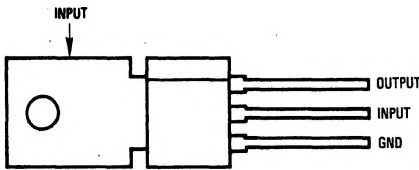

TL/H/7767-16

Power Package TO-202 (P)
 Order Number LM320MP-5.0,
 LM320MP-12 or LM320MP-15
 See NS Package Number P03A

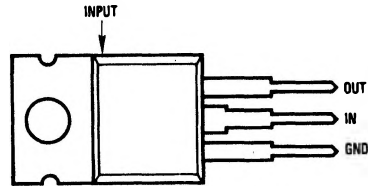

TL/H/7767-17

Power Package TO-220 (T)
 Order Number LM320T-5.0, LM320T-12 or LM320T-15
 See NS Package Number T03B

Schematic Diagrams

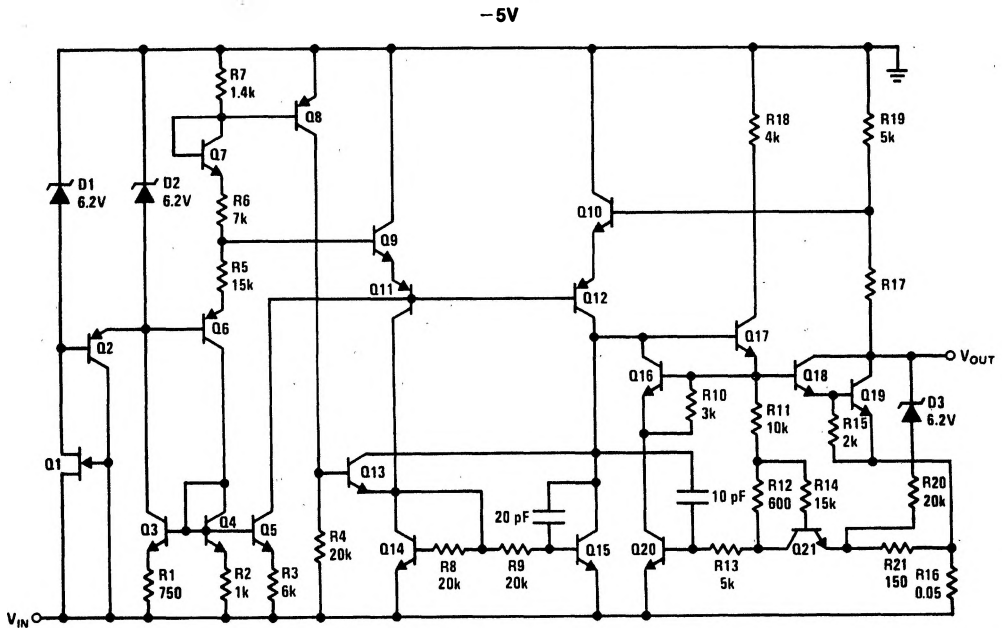

TL/H/7767-18

Schematic Diagrams (Continued)

-12V and -15V

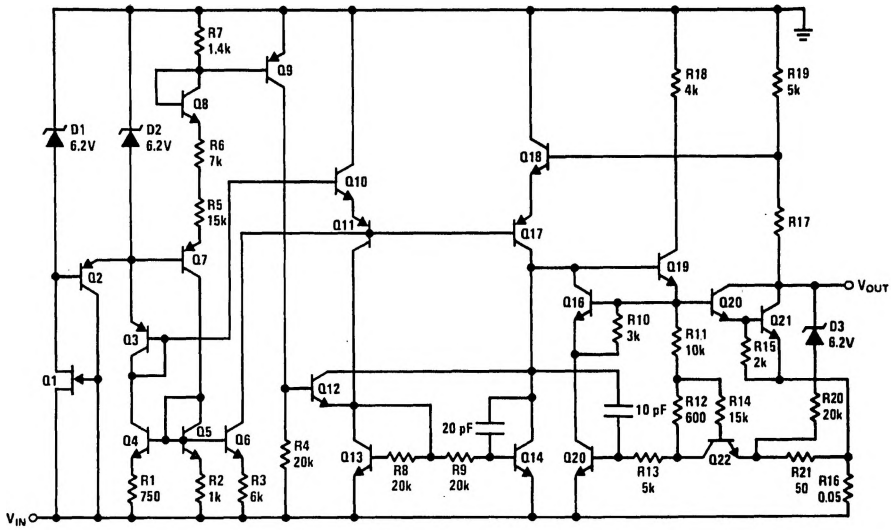

TL/H/7767-19