

LM3100 SIMPLE SWITCHER® Synchronous 1MHz 1.5A Step-Down Voltage Regulator

 Check for Samples: [LM3100](#)

FEATURES

- Input Voltage Range 4.5V - 36V
- 1.5A Output Current
- 0.8V, $\pm 1.5\%$ Reference
- Integrated 40V, Dual N-Channel Buck Synchronous Switches
- Low Component Count and Small Solution Size
- No Loop Compensation Required
- Ultra-Fast Transient Response
- Stable with Ceramic and Other Low ESR Capacitors
- Programmable Switching Frequency up to 1MHz
- Max. Duty Cycle Limited During Start-Up
- Valley Current Limit
- Precision Internal Reference for Adjustable Output Voltage Down to 0.8V
- Thermal Shutdown
- Thermally Enhanced HTSSOP-20 Package

- Automotive Telematics and Body Electronics
- Point of Load Regulators
- Storage Systems
- Broadband Infrastructure
- Direct Conversion from 2/3/4 Cell Lithium Batteries Systems

DESCRIPTION

The LM3100 Synchronously Rectified Buck Converter features all functions needed to implement a highly efficient, cost effective buck regulator capable of supplying 1.5A to loads with voltages as low as 0.8V. Dual 40V N-Channel synchronous MOSFET switches allow for low external component thus reducing complexity and minimizing board space. The LM3100 is designed to work exceptionally well with ceramic and other very low ESR output capacitors. The Constant ON-Time (COT) regulation scheme requires no loop compensation, results in fast load transient response, and simplifies circuit implementation. Through the use of a unique design the regulator does not rely on output capacitor ESR for stability, as do most other COT regulators. The operating frequency remains nearly constant with line and load variations due to the inverse relationship between the input voltage and the on-time. The operating frequency can be externally programmed up to 1MHz. Protection features include V_{CC} under-voltage lockout, thermal shutdown and gate drive under-voltage lockout. The part is available in a thermally enhanced HTSSOP-20 package

TYPICAL APPLICATIONS

- 5VDC, 12VDC, 24VDC, 12VAC, and 24VAC Systems
- Embedded Systems
- Industrial Controls

Typical Application

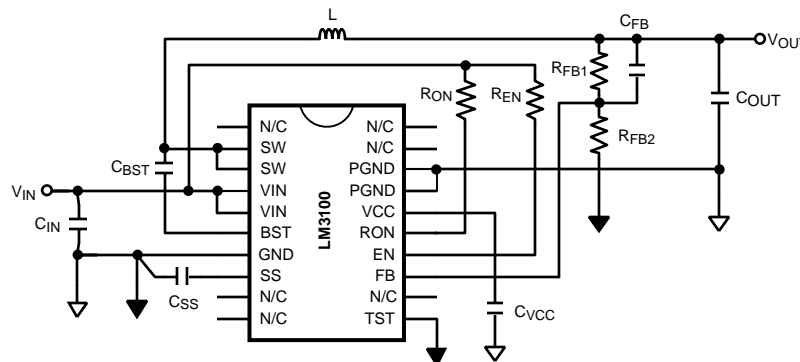

Please be aware that an important notice concerning availability, standard warranty, and use in critical applications of Texas Instruments semiconductor products and disclaimers thereto appears at the end of this data sheet.

All trademarks are the property of their respective owners.

Connection Diagram

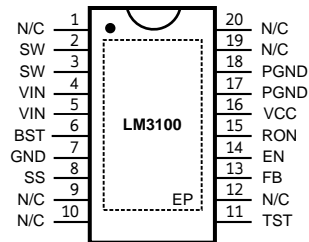

Figure 1. 20-lead Plastic HTSSOP (PWP0020A)

PIN DESCRIPTIONS

Pin	Name	Description	Application Information
1,9,10,12,19,20	N/C	No Connection	These pins must be left unconnected.
2, 3	SW	Switching Node	Internally connected to the buck switch source. Connect to output inductor.
4, 5	VIN	Input supply voltage	Supply pin to the device. Nominal input range is 4.5V to 36V.
6	BST	Connection for bootstrap capacitor	Connect a 0.033 μ F capacitor from SW pin to this pin. An internal diode charges the capacitor during the high-side switch off-time.
7	GND	Analog Ground	Ground for all internal circuitry other than the synchronous switches.
8	SS	Soft-start	An internal 8 μ A current source charges an external capacitor to provide the soft- start function.
11	TST	Test mode enable pin	Force the device into test mode. Must be connected to ground for normal operation.
13	FB	Feedback	Internally connected to the regulation and over-voltage comparators. The regulation setting is 0.8V at this pin. Connect to feedback divider.
14	EN	Enable pin	Connect a voltage higher than 1.26V to enable the regulator.
15	RON	On-time Control	An external resistor from VIN to this pin sets the high-side switch on-time.
16	VCC	Start-up regulator Output	Nominally regulated to 6V. Connect a capacitor of not less than 680nF between VCC and GND for stable operation.
17, 18	PGND	Power Ground	Synchronous rectifier MOSFET source connection. Tie to power ground plane.
DAP	EP	Exposed Pad	Thermal connection pad, connect to GND.



These devices have limited built-in ESD protection. The leads should be shorted together or the device placed in conductive foam during storage or handling to prevent electrostatic damage to the MOS gates.

Absolute Maximum Ratings⁽¹⁾⁽²⁾

VIN, RON to GND		-0.3V to 40V
SW to GND		-0.3V to 40V
SW to GND (Transient)		-2V (< 100ns)
VIN to SW		-0.3V to 40V
BST to SW		-0.3V to 7V
All Other Inputs to GND		-0.3V to 7V
ESD Rating ⁽³⁾	Human Body Model	±2kV
Storage Temperature Range		-65°C to +150°C
Junction Temperature (T _J)		150°C

- (1) Absolute Maximum Ratings are limits beyond which damage to the device may occur. Operating Ratings are conditions under which operation of the device is intended to be functional. For guaranteed specifications and test conditions, see the Electrical Characteristics.
- (2) If Military/Aerospace specified devices are required, please contact the National Semiconductor Sales Office/ Distributors for availability and specifications.
- (3) The human body model is a 100pF capacitor discharged through a 1.5kΩ resistor into each pin.

Operating Ratings⁽¹⁾

Supply Voltage Range (VIN)		4.5V to 36V
Junction Temperature Range (T _J)		-40°C to + 125°C
Thermal Resistance (θ _{JC}) ⁽²⁾		6.5°C/W

- (1) Absolute Maximum Ratings are limits beyond which damage to the device may occur. Operating Ratings are conditions under which operation of the device is intended to be functional. For guaranteed specifications and test conditions, see the Electrical Characteristics.
- (2) θ_{JC} measurements are performed in general accordance with Mil-Std 883B, Method 1012.1 and utilizes the copper heat sink technique. Copper Heat Sink @ 60°C.

Electrical Characteristics

Specifications with standard type are for $T_J = 25^\circ\text{C}$ only; limits in boldface type apply over the full Operating Junction Temperature (T_J) range. Minimum and Maximum limits are guaranteed through test, design, or statistical correlation. Typical values represent the most likely parametric norm at $T_J = 25^\circ\text{C}$, and are provided for reference purposes only. Unless otherwise stated the following conditions apply: $V_{IN} = 18\text{V}$, $V_{OUT} = 3.3\text{V}$.

Symbol	Parameter	Conditions	Min	Typ	Max	Units
Start-Up Regulator, V_{CC}						
V_{CC}	V_{CC} output voltage	$C_{CC} = 680\text{nF}$, no load	5.0	6.0	7.2	V
$V_{IN} - V_{CC}$	$V_{IN} - V_{CC}$ dropout voltage	$I_{CC} = 2\text{mA}$		50	140	mV
		$I_{CC} = 20\text{mA}$		350	570	
I_{VCC}	V_{CC} current limit ⁽¹⁾	$V_{CC} = 0\text{V}$	40	65		mA
$V_{CC-UVLO}$	V_{CC} under-voltage lockout threshold (UVLO)	V_{IN} increasing	3.6	3.75	3.85	V
$V_{CC-UVLO-HYS}$	V_{CC} UVLO hysteresis	V_{IN} decreasing		130		mV
$t_{VCC-UVLO-D}$	V_{CC} UVLO filter delay			3		μs
I_{IN}	I_{IN} operating current	No switching, $V_{FB} = 1\text{V}$		0.7	1	mA
I_{IN-SD}	I_{IN} operating current, Device shutdown	$V_{EN} = 0\text{V}$		17	30	μA
Switching Characteristics						
$R_{DS-UP-ON}$	Main MOSFET $R_{ds(on)}$			0.18	0.35	Ω
$R_{DS-DN-ON}$	Syn. MOSFET $R_{ds(on)}$			0.11	0.2	Ω
V_{G-UVLO}	Gate drive voltage UVLO	$V_{BST} - V_{SW}$ increasing		3.3	4	V
Soft-start						
I_{SS}	SS pin source current	$V_{SS} = 0.5\text{V}$	6	8	9.8	μA
Current Limit						
I_{CL}	Syn. MOSFET current limit threshold			1.9		A
ON/OFF Timer						
t_{ON}	ON timer pulse width	$V_{IN} = 10\text{V}$, $R_{ON} = 100\text{ k}\Omega$		1.38		μs
		$V_{IN} = 30\text{V}$, $R_{ON} = 100\text{ k}\Omega$		0.47		
t_{ON-MIN}	ON timer minimum pulse width			200		ns
t_{OFF}	OFF timer pulse width			260		ns
Enable Input						
V_{EN}	EN Pin input threshold	V_{EN} rising	1.236	1.26	1.285	V
V_{EN-HYS}	Enable threshold hysteresis	V_{EN} falling		90		mV
Regulation and Over-Voltage Comparator						
V_{FB}	In-regulation feedback voltage	$V_{SS} \geq 0.8\text{V}$ $T_J = -40^\circ\text{C}$ to $+125^\circ\text{C}$	0.784	0.8	0.816	V
		$V_{SS} \geq 0.8\text{V}$ $T_J = 0^\circ\text{C}$ to $+125^\circ\text{C}$	0.788		0.812	
V_{FB-OV}	Feedback over-voltage threshold		0.894	0.920	0.940	V
I_{FB}				5	100	nA
Thermal Shutdown						
T_{SD}	Thermal shutdown temperature	T_J rising		165		$^\circ\text{C}$
T_{SD-HYS}	Thermal shutdown temperature hysteresis	T_J falling		20		$^\circ\text{C}$

(1) V_{CC} provides self bias for the internal gate drive and control circuits. Device thermal limitations limit external loading.

Typical Performance Characteristics

All curves taken at $V_{IN} = 18V$ with configuration in typical application circuit for $V_{OUT} = 3.3V$ shown in this datasheet. $T_A = 25^\circ C$, unless otherwise specified.

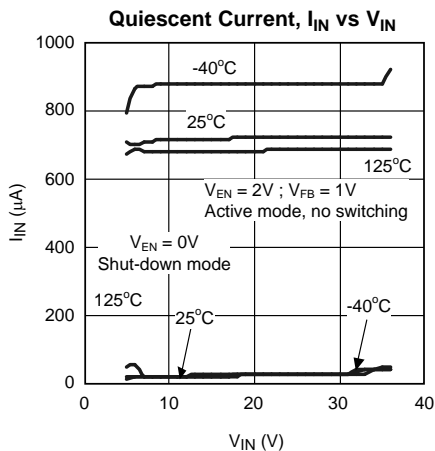

Figure 2.

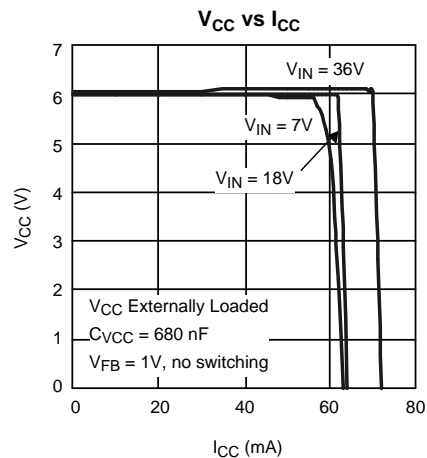

Figure 3.

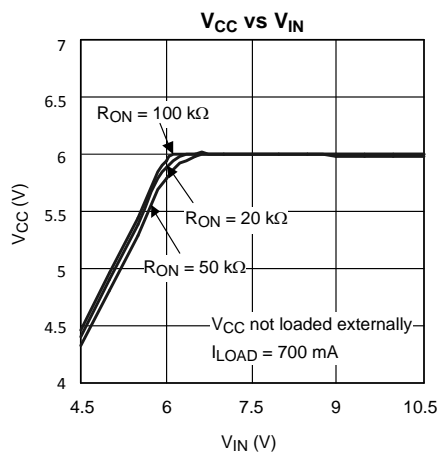

Figure 4.

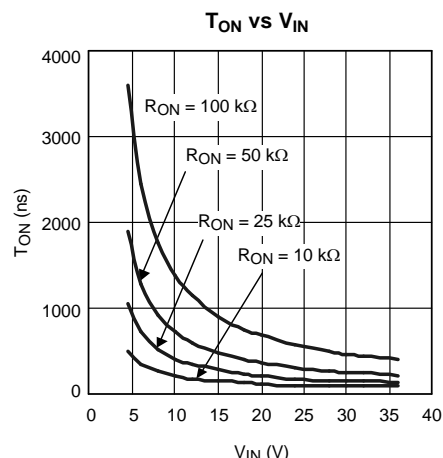

Figure 5.

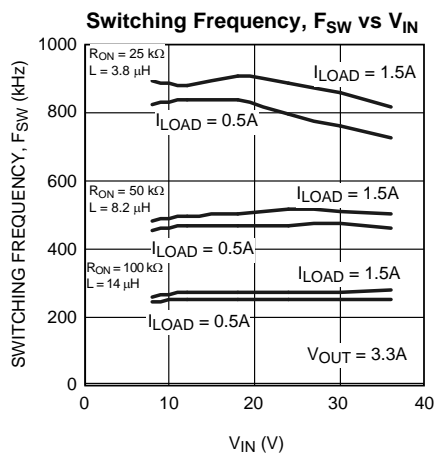

Figure 6.

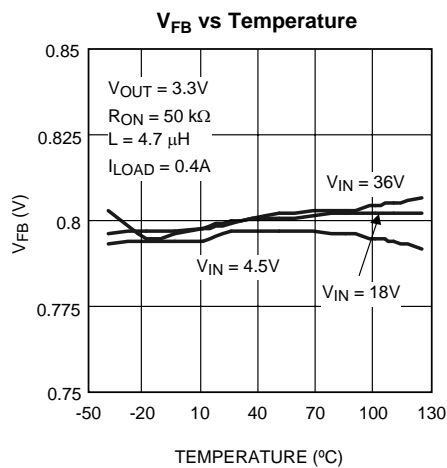

Figure 7.

Typical Performance Characteristics (continued)

All curves taken at $V_{IN} = 18V$ with configuration in typical application circuit for $V_{OUT} = 3.3V$ shown in this datasheet. $T_A = 25^\circ C$, unless otherwise specified.

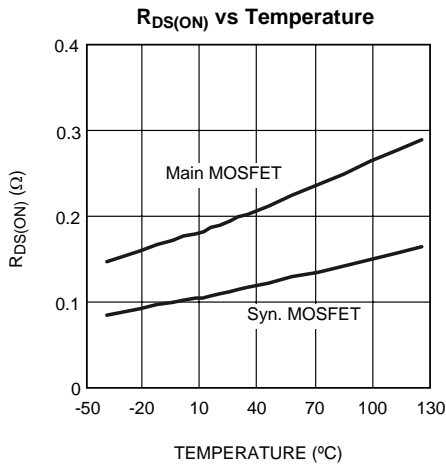

Figure 8.

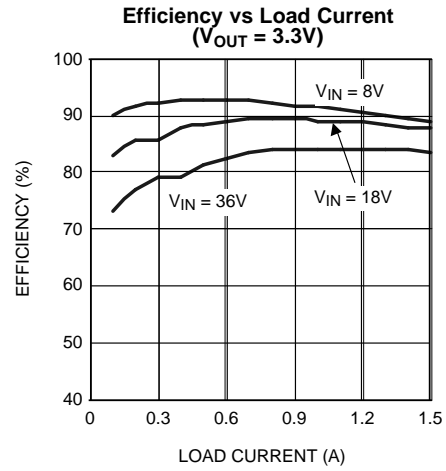

Figure 9.

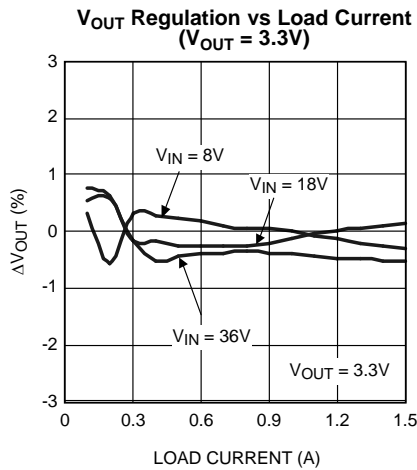

Figure 10.

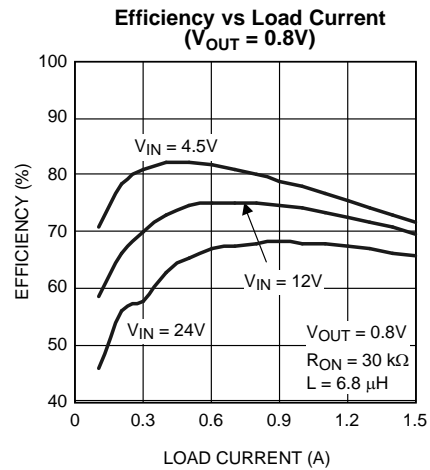

Figure 11.

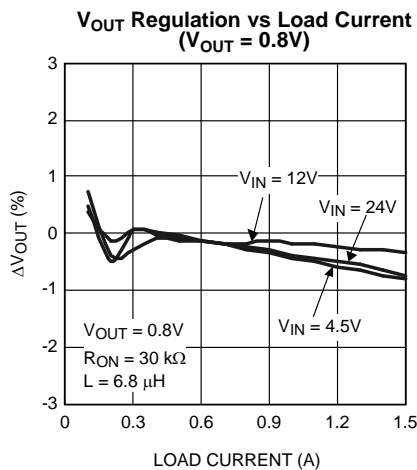

Figure 12.

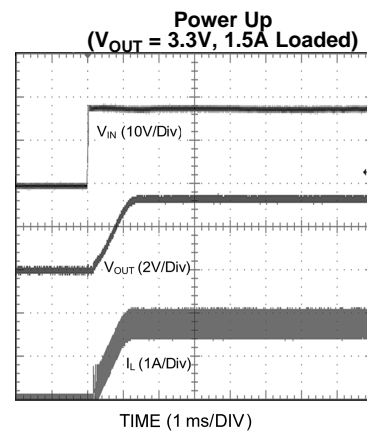

Figure 13.

Typical Performance Characteristics (continued)

All curves taken at $V_{IN} = 18V$ with configuration in typical application circuit for $V_{OUT} = 3.3V$ shown in this datasheet. $T_A = 25^\circ C$, unless otherwise specified.

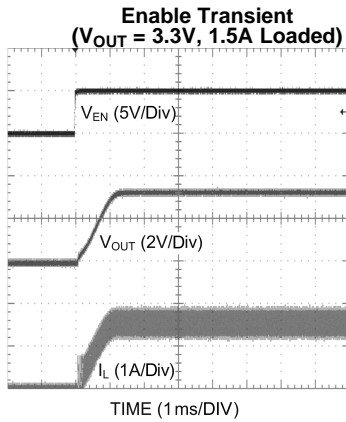

Figure 14.

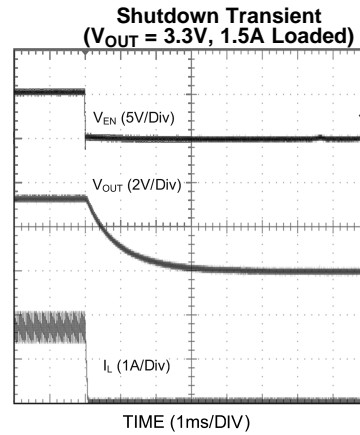

Figure 15.

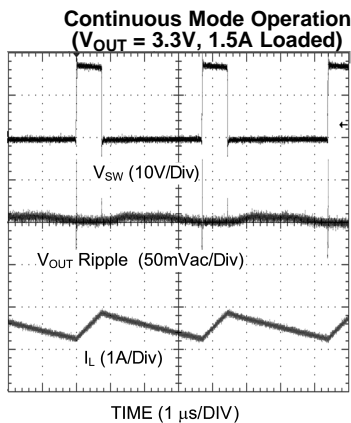

Figure 16.

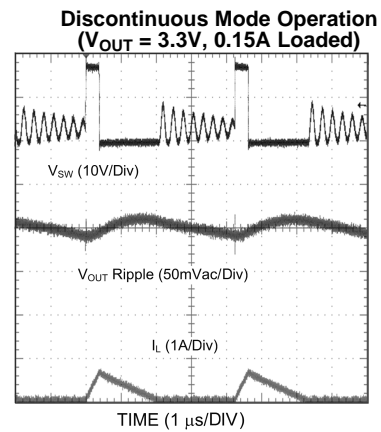

Figure 17.

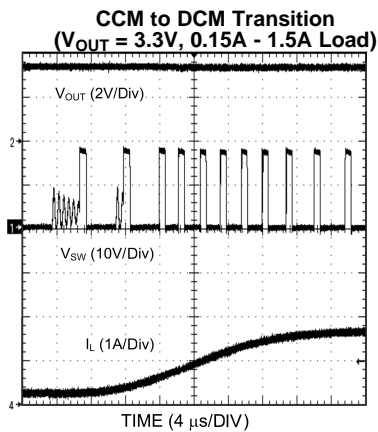

Figure 18.

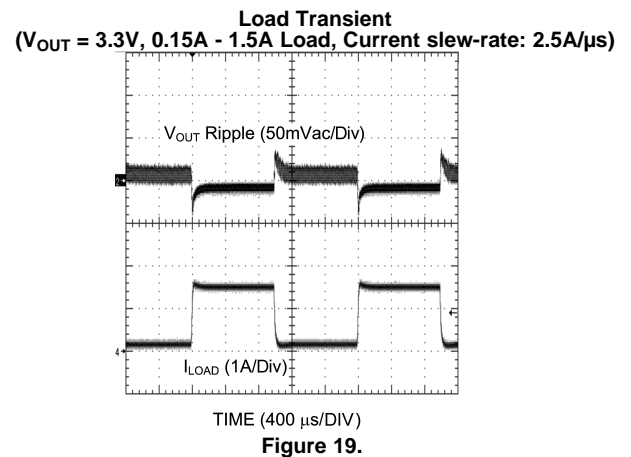
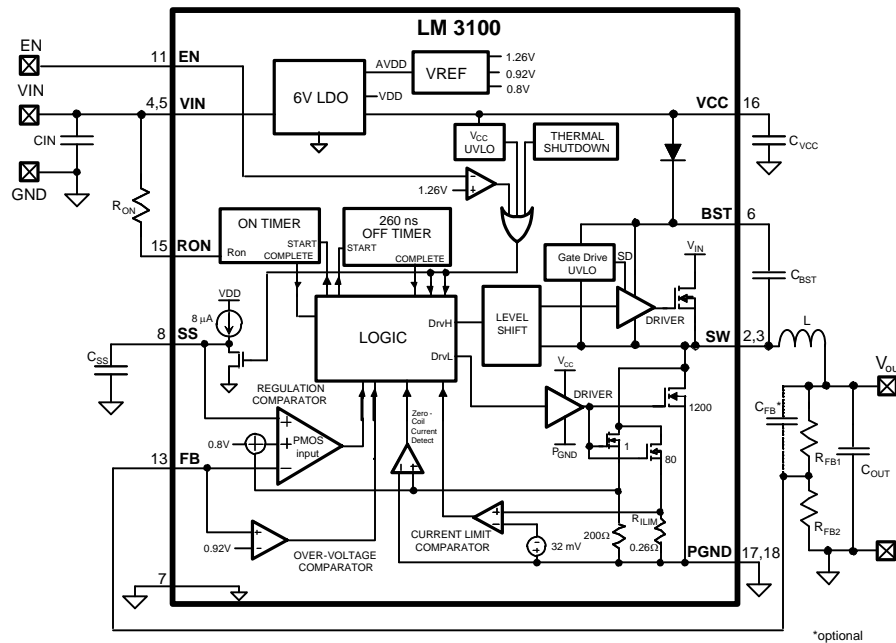

Figure 19.

SIMPLIFIED FUNCTIONAL BLOCK DIAGRAM



Functional Description

The LM3100 Step Down Switching Regulator features all functions needed to implement a cost effective, efficient buck power converter capable of supplying 1.5A to a load. This voltage regulator contains Dual 40V N-Channel buck synchronous switches and is available in a thermally enhanced HTSSOP-20 package. The Constant ON-Time (COT) regulation scheme requires no loop compensation, results in fast load transient response, and simplifies circuit implementation. It will work correctly even with an all ceramic output capacitor network and does not rely on the output capacitor's ESR for stability. The operating frequency remains constant with line and load variations due to the inverse relationship between the input voltage and the on-time. The valley current limit detection circuit, internally set at 1.9A, inhibits the high-side switch until the inductor current level subsides. Please refer to the functional block diagram with a typical application circuit.

The LM3100 can be applied in numerous applications and can operate efficiently from inputs as high as 36V. Protection features include: Thermal shutdown, V_{CC} under-voltage lockout, gate drive under-voltage lockout.

Hysteretic Control Circuit Overview

The LM3100 buck DC-DC regulator employs a control scheme in which the high-side switch on-time varies inversely with the line voltage (V_{IN}). Control is based on a comparator and the one-shot on-timer, with the output voltage feedback (FB) compared with an internal reference of 0.8V. If the FB level is below the reference the buck switch is turned on for a fixed time determined by the input voltage and a programming resistor (R_{ON}). Following the on-time, the switch remains off for a minimum of 260ns. If FB is below the reference at that time the switch turns on again for another on-time period. The switching will continue until regulation is achieved.

The regulator will operate in discontinuous conduction mode at light load currents, and continuous conduction mode with heavy load current. In discontinuous conduction mode (DCM), current through the output inductor starts at zero and ramps up to a peak during the on-time, then ramps back to zero before the end of the off-time. The next on-time period starts when the voltage at FB falls below the internal reference. Until then the inductor current remains zero and the load is supplied entirely by the output capacitor. In this mode the operating frequency is lower than in continuous conduction mode, and varies with load current. Conversion efficiency is maintained since the switching losses are reduced with the reduction in load and switching frequency. The discontinuous operating frequency can be calculated approximately as follows:

$$F_{SW} = \frac{V_{OUT} (V_{IN} - 1) \times L \times 1.18 \times 10^{20} \times I_{OUT}}{(V_{IN} - V_{OUT}) \times R_{ON}^2} \quad (1)$$

In continuous conduction mode (CCM), current always flows through the inductor and never reaches zero during the off-time. In this mode, the operating frequency remains relatively constant with load and line variations. The CCM operating frequency can be calculated approximately as follows:

$$F_{SW} = \frac{V_{OUT}}{1.3 \times 10^{-10} \times R_{ON}} \quad (2)$$

The output voltage is set by two external resistors (R_{FB1} , R_{FB2}). The regulated output voltage is calculated as follows:

$$V_{OUT} = 0.8V \times (R_{FB1} + R_{FB2})/R_{FB2} \quad (3)$$

Start-up Regulator (V_{CC})

The start-up regulator is integrated within LM3100. The input pin (V_{IN}) can be connected directly to line voltage up to 36V, with transient capability of 40V. The V_{CC} output regulates at 6V, and is current limited to 65 mA. Upon power up, the regulator sources current into the external capacitor at V_{CC} (C_{VCC}). C_{VCC} must be at least 680nF for stability. When the voltage on the VCC pin reaches the under-voltage lockout threshold of 3.75V, the buck switch is enabled and the Soft-start pin is released to allow the soft-start capacitor (C_{SS}) to charge.

The minimum input voltage is determined by the dropout voltage of V_{CC} regulator, and the V_{CC} UVLO falling threshold (≈ 3.7 V). If V_{IN} is less than $\approx 4.0V$, the V_{CC} UVLO activates to shut off the output.

Regulation Comparator

The feedback voltage at FB pin is compared to the internal reference voltage of 0.8V. In normal operation (the output voltage is regulated), an on-time period is initiated when the voltage at FB falls below 0.8V. The buck switch stays on for the on-time, causing the FB voltage to rise above 0.8V. After the on-time period, the buck switch stays off until the FB voltage falls below 0.8V again. Bias current at the FB pin is nominally 100 nA.

Over-Voltage Comparator

The voltage at FB pin is compared to an internal 0.92V reference. If the feedback voltage rises above 0.92V the on-time pulse is immediately terminated. This condition can occur if the input voltage, or the output load, changes suddenly. Once the OVP is activated, the buck switch remains off until the voltage at FB pin falls below 0.92V. The low side switch will stay on to discharge the inductor energy until the inductor current decays to zero. The low side switch will be turned off.

ON-Time Timer, Shutdown

The ON-Time of LM3100 main switch is determined by the R_{ON} resistor and the input voltage (V_{IN}), and is calculated from:

$$t_{ON} = \frac{1.3 \times 10^{-10} \times R_{ON}}{V_{IN}} \quad (4)$$

The inverse relationship of t_{ON} and V_{IN} results in a nearly constant switching frequency as V_{IN} is varied. R_{ON} should be selected for a minimum on-time (at maximum V_{IN}) greater than 200 ns for proper current limit operation. This requirement limits the maximum frequency for each application, depending on V_{IN} and V_{OUT} , calculated from [Equation 5](#):

$$F_{SW(MAX)} = \frac{V_{OUT}}{V_{IN(MAX)} \times 200 \text{ ns}} \quad (5)$$

The LM3100 can be remotely shut down by taking the EN pin below 1.1V. Refer to [Figure 20](#). In this mode the SS pin is internally grounded, the on-timer is disabled, and bias currents are reduced. Releasing the EN pin allows normal operation to resume. For normal operation, the voltage at the EN pin is set between 1.5V and 3.0V, depending on V_{IN} and the external pull-up resistor. For all cases, this voltage must be limited not to exceed 7V.

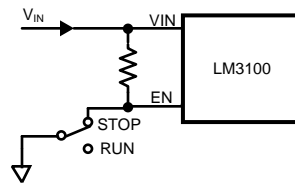

Figure 20. Shutdown Implementation

Current Limit

Current limit detection occurs during the off-time by monitoring the re-circulating current through the low-side synchronous switch. Referring to Functional Block Diagram, when the buck switch is turned off, inductor current flows through the load, into PGND, and through the internal low-side synchronous switch. If that current exceeds 1.9A the current limit comparator toggles, forcing a delay to the start of the next on-time period. The next cycle starts when the re-circulating current falls back below 1.9A and the voltage at FB is below 0.8V. The inductor current is monitored during the low-side switch on-time. As long as the overload condition persists and the inductor current exceeds 1.9A, the high-side switch will remain inhibited. The operating frequency is lower during an over-current due to longer than normal off-times.

Figure 21 illustrates an inductor current waveform, the average inductor current is equal to the output current, I_{OUT} in steady state. When an overload occurs, the inductor current will increase until it exceeds the current limit threshold, 1.9A. Then the control keeps the high-side switch off until the inductor current ramps down below 1.9A. Within each on-time period, the current ramps up an amount equal to:

$$\Delta I = \frac{(V_{IN} - V_{OUT}) \times t_{ON}}{L} \quad (6)$$

During this time the LM3100 is in a constant current mode, with an average load current (I_{OCL}) equal to $1.9A + \Delta I/2$.

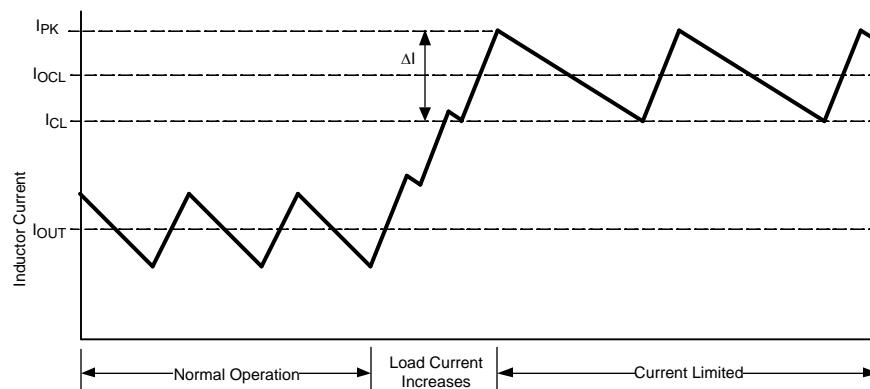

Figure 21. Inductor Current - Current Limit Operation

N-Channel Buck Switch and Driver

The LM3100 integrates an N-Channel buck (high-side) switch and associated floating high voltage gate driver. The gate drive circuit works in conjunction with an external bootstrap capacitor and an internal high voltage diode. A 33 nF capacitor (C_{BST}) connected between BST and SW pins provides voltage to the high-side driver during the buck switch on-time. During each off-time, the SW pin falls to approximately -1V and C_{BST} charges from the V_{CC} supply through the internal diode. The minimum off-time of 260ns ensures adequate time each cycle to recharge the bootstrap capacitor.

Soft-Start

The soft-start feature allows the converter to gradually reach a steady state operating point, thereby reducing start-up stresses and current surges. Upon turn-on, after V_{CC} reaches the under-voltage threshold, an internal $8\mu\text{A}$ current source charges up the external capacitor at the SS pin. The ramping voltage at SS (and the non-inverting input of the regulation comparator) ramps up the output voltage in a controlled manner.

An internal switch grounds the SS pin if any of the following cases happen: (i) V_{CC} falls below the under-voltage lock-out threshold; (ii) a thermal shutdown occurs; or (iii) the EN pin is grounded. Alternatively, the converter can be disabled by connecting the SS pin to ground using an external switch. Releasing the switch allows the SS pin return to pull high and the output voltage returns to normal. The shut-down configuration is shown in [Figure 22](#).

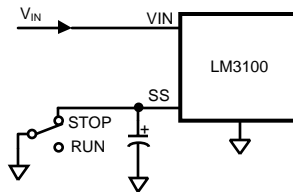

Figure 22. Alternate Shutdown Implementation

Thermal Protection

The LM3100 should be operated so the junction temperature does not exceed the maximum limit. An internal Thermal Shutdown circuit, which activates (typically) at 165°C , takes the controller to a low power reset state by disabling the buck switch and the on-timer, and grounding the SS pin. This feature helps prevent catastrophic failures from accidental device overheating. When the junction temperature falls back below 145°C (typical hysteresis = 20°C), the SS pin is released and normal operation resumes.

Applications Information

EXTERNAL COMPONENTS

The following guidelines can be used to select the external components.

R_{FB1} and R_{FB2} : The ratio of these resistors is calculated from:

$$\frac{R_{FB1}}{R_{FB2}} = \frac{V_{OUT}}{0.8V} - 1 \quad (7)$$

R_{FB1} and R_{FB2} should be chosen from standard value resistors in the range of $1.0\text{ k}\Omega$ - $10\text{ k}\Omega$ which satisfy the above ratio.

For $V_{OUT} = 0.8\text{V}$, the FB pin can be connected to the output directly. However, the converter operation needs a minimum inductor current ripple to maintain good regulation when no load is connected. This minimum load is about $10\text{ }\mu\text{A}$ and can be implemented by adding a pre-load resistor to the output.

R_{ON} : The minimum value for R_{ON} is calculated from:

$$R_{ON} \geq \frac{200\text{ ns} \times V_{IN(MAX)}}{1.3 \times 10^{-10}} \quad (8)$$

[Equation 2](#) in [Hysteretic Control Circuit Overview](#) section can be used to select R_{ON} if a specific frequency is desired as long as the above limitation is met.

L: The main parameter affected by the inductor is the output current ripple amplitude (I_{OR}). The maximum allowable (I_{OR} must be determined at both the minimum and maximum nominal load currents. At minimum load current, the lower peak must not reach 0A . At maximum load current, the upper peak must not exceed the current limit threshold (1.9A). The allowable ripple current is calculated from the following equations:

$$I_{OR(MAX1)} = 2 \times I_{O(min)} \quad (9)$$

or

$$I_{OR(MAX2)} = 2 \times (1.9A - I_{O(max)}) \quad (10)$$

The lesser of the two ripple amplitudes calculated above is then used in the following equation:

$$L = \frac{V_{OUT} \times (V_{IN} - V_{OUT})}{I_{OR} \times F_S \times V_{IN}} \quad (11)$$

where V_{IN} is the maximum input voltage and F_S is determined from [Equation 1](#). This provides a value for L . The next larger standard value should be used. L should be rated for the I_{PK} current level shown in [Figure 21](#).

Figure 23. Inductor Selector for $V_{OUT} = 3.3V$

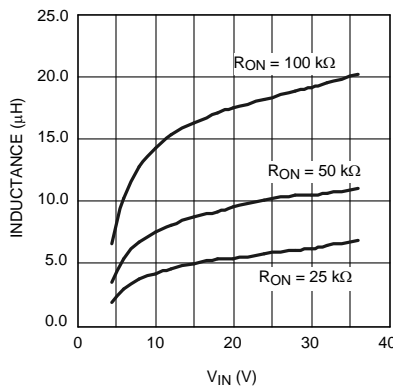
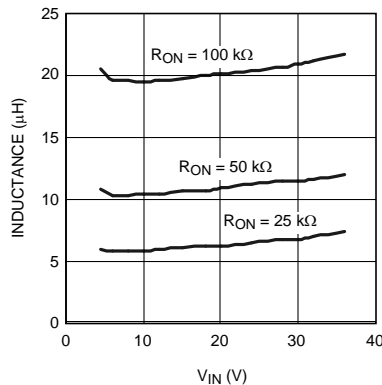

Figure 24. Inductor Selector for $V_{OUT} = 0.8V$



C_{VCC} : The capacitor on the V_{CC} output provides not only noise filtering and stability, but also prevents false triggering of the V_{CC} UVLO at the buck switch on/off transitions. For this reason, C_{VCC} should be no smaller than 680 nF for stability, and should be a good quality, low ESR, ceramic capacitor.

C_O and C_{O3} : C_O should generally be no smaller than 10 μF . Experimentation is usually necessary to determine the minimum value for C_O , as the nature of the load may require a larger value. A load which creates significant transients requires a larger value for C_O than a fixed load.

C_{O3} is a small value ceramic capacitor to further suppress high frequency noise at V_{OUT} . A 47nF is recommended, located close to the LM3100.

C_{IN} and C_{IN3} : C_{IN} 's purpose is to supply most of the switch current during the on-time, and limit the voltage ripple at V_{IN} , assume the voltage source feeding V_{IN} has an output impedance greater than zero. If the source's dynamic impedance is high (effectively a current source), C_{IN} supplies the average input current, but not the ripple current.

At maximum load current, when the buck switch turns on, the current into V_{IN} suddenly increases to the lower peak of the inductor's ripple current, ramps up to the peak value, then drop to zero at turn-off. The average current during the on-time is the load current. For a worst case calculation, C_{IN} must supply this average load current during the maximum on-time. C_{IN} is calculated from:

$$C_{IN} = \frac{I_{OUT} \times t_{ON}}{\Delta V} \quad (12)$$

where I_{OUT} is the load current, t_{ON} is the maximum on-time, and ΔV is the allowable ripple voltage at V_{IN} .

C_{IN3} 's purpose is to help avoid transients and ringing due to long lead inductance at V_{IN} . A low ESR, 0.1 μ F ceramic chip capacitor is recommended, located close to the LM3100.

C_{BST} : The recommended value for C_{BST} is 33 nF. A high quality ceramic capacitor with low ESR is recommended as C_{BST} supplies a surge current to charge the buck switch gate at turn-on. A low ESR also helps ensure a complete recharge during each off-time.

C_{SS} : The capacitor at the SS pin determines the soft-start time, i.e. the time for the reference voltage at the regulation comparator, and the output voltage, to reach their final value. The time is determined from the following:

$$t_{SS} = \frac{C_{SS} \times 0.8V}{8 \mu A} \quad (13)$$

C_{FB} : If output voltage is higher than 1.6V, this feedback capacitor is needed for Discontinuous Conduction Mode to improve the output ripple performance, the recommended value for C_{FB} is 10 nF.

PC BOARD LAYOUT

The LM3100 regulation, over-voltage, and current limit comparators are very fast, and will respond to short duration noise pulses. Layout considerations are therefore critical for optimum performance. The layout must be as neat and compact as possible, and all external components must be as close as possible to their associated pins. Refer to the functional block diagram, the loop formed by C_{IN} , the high and low-side switches internal to the IC, and the PGND pin should be as small as possible. The PGND connection to C_{in} should be as short and direct as possible. There should be several vias connecting the C_{in} ground terminal to the ground plane placed as close to the capacitor as possible. The boost capacitor should be connected as close to the SW and BST pins as possible. The feedback divider resistors and the C_{FB} capacitor should be located close to the FB pin. A long trace run from the top of the divider to the output is generally acceptable since this is a low impedance node. Ground the bottom of the divider directly to the GND (pin 7). The output capacitor, C_{OUT} , should be connected close to the load and tied directly into the ground plane. The inductor should connect close to the SW pin with as short a trace as possible to help reduce the potential for EMI (electro-magnetic interference) generation.

If it is expected that the internal dissipation of the LM3100 will produce excessive junction temperatures during normal operation, good use of the PC board's ground plane can help considerably to dissipate heat. The exposed pad on the bottom of the IC package can be soldered to a ground plane and that plane should extend out from beneath the IC to help dissipate the heat. The exposed pad is internally connected to the IC substrate. Additionally the use of thick copper traces, where possible, can help conduct heat away from the IC. Using numerous vias to connect the die attach pad to an internal ground plane is a good practice. Judicious positioning of the PC board within the end product, along with the use of any available air flow (forced or natural convection) can help reduce the junction temperature.

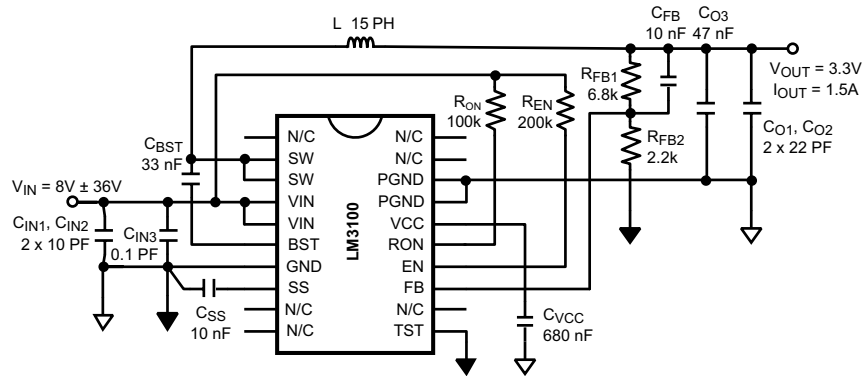

Figure 25. Typical Application Schematic for $V_{OUT} = 3.3V$

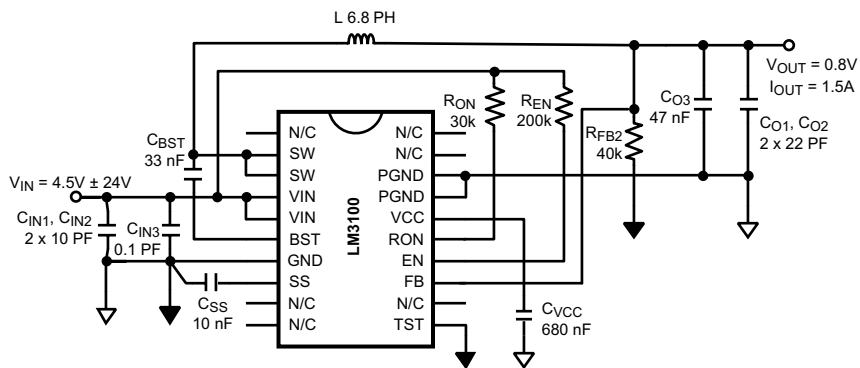

Figure 26. Typical Application Schematic for $V_{OUT} = 0.8V$

PACKAGING INFORMATION

Orderable Device	Status (1)	Package Type	Package Drawing	Pins	Package Qty	Eco Plan (2)	Lead/Ball Finish	MSL Peak Temp (3)	Op Temp (°C)	Top-Side Markings (4)	Samples
LM3100MH	ACTIVE	HTSSOP	PWP	20	73	TBD	Call TI	Call TI	-40 to 125	LM3100 MH	Samples
LM3100MH/NOPB	ACTIVE	HTSSOP	PWP	20	73	Green (RoHS & no Sb/Br)	CU SN	Level-1-260C-UNLIM	-40 to 125	LM3100 MH	Samples
LM3100MHX	ACTIVE	HTSSOP	PWP	20	2500	TBD	Call TI	Call TI	-40 to 125	LM3100 MH	Samples
LM3100MHX/NOPB	ACTIVE	HTSSOP	PWP	20	2500	Green (RoHS & no Sb/Br)	CU SN	Level-1-260C-UNLIM	-40 to 125	LM3100 MH	Samples

(1) The marketing status values are defined as follows:

ACTIVE: Product device recommended for new designs.

LIFEBUY: TI has announced that the device will be discontinued, and a lifetime-buy period is in effect.

NRND: Not recommended for new designs. Device is in production to support existing customers, but TI does not recommend using this part in a new design.

PREVIEW: Device has been announced but is not in production. Samples may or may not be available.

OBSOLETE: TI has discontinued the production of the device.

(2) Eco Plan - The planned eco-friendly classification: Pb-Free (RoHS), Pb-Free (RoHS Exempt), or Green (RoHS & no Sb/Br) - please check <http://www.ti.com/productcontent> for the latest availability information and additional product content details.

TBD: The Pb-Free/Green conversion plan has not been defined.

Pb-Free (RoHS): TI's terms "Lead-Free" or "Pb-Free" mean semiconductor products that are compatible with the current RoHS requirements for all 6 substances, including the requirement that lead not exceed 0.1% by weight in homogeneous materials. Where designed to be soldered at high temperatures, TI Pb-Free products are suitable for use in specified lead-free processes.

Pb-Free (RoHS Exempt): This component has a RoHS exemption for either 1) lead-based flip-chip solder bumps used between the die and package, or 2) lead-based die adhesive used between the die and leadframe. The component is otherwise considered Pb-Free (RoHS compatible) as defined above.

Green (RoHS & no Sb/Br): TI defines "Green" to mean Pb-Free (RoHS compatible), and free of Bromine (Br) and Antimony (Sb) based flame retardants (Br or Sb do not exceed 0.1% by weight in homogeneous material)

(3) MSL, Peak Temp. -- The Moisture Sensitivity Level rating according to the JEDEC industry standard classifications, and peak solder temperature.

(4) Only one of markings shown within the brackets will appear on the physical device.

Important Information and Disclaimer: The information provided on this page represents TI's knowledge and belief as of the date that it is provided. TI bases its knowledge and belief on information provided by third parties, and makes no representation or warranty as to the accuracy of such information. Efforts are underway to better integrate information from third parties. TI has taken and continues to take reasonable steps to provide representative and accurate information but may not have conducted destructive testing or chemical analysis on incoming materials and chemicals. TI and TI suppliers consider certain information to be proprietary, and thus CAS numbers and other limited information may not be available for release.

In no event shall TI's liability arising out of such information exceed the total purchase price of the TI part(s) at issue in this document sold by TI to Customer on an annual basis.

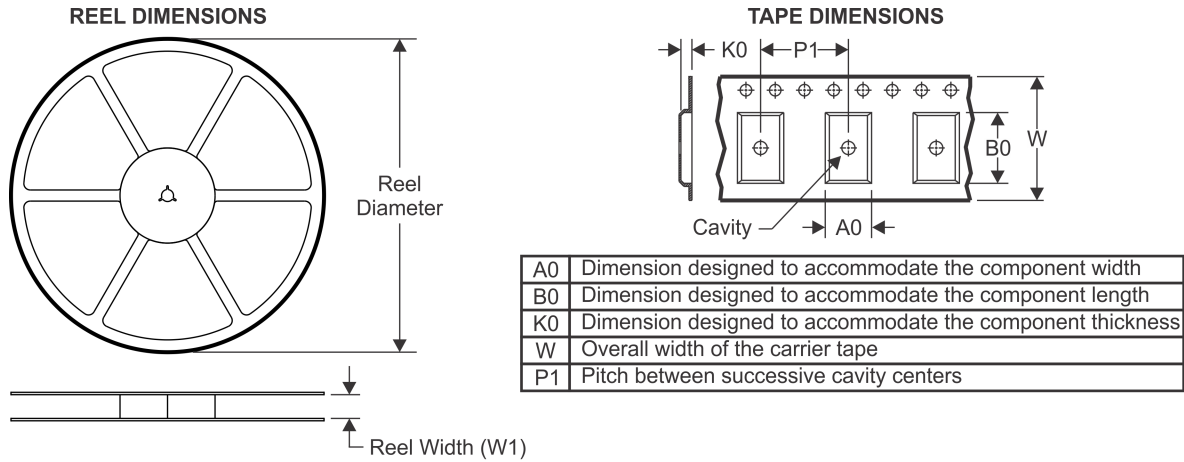
TAPE AND REEL INFORMATION

QUADRANT ASSIGNMENTS FOR PIN 1 ORIENTATION IN TAPE

*All dimensions are nominal

Device	Package Type	Package Drawing	Pins	SPQ	Reel Diameter (mm)	Reel Width W1 (mm)	A0 (mm)	B0 (mm)	K0 (mm)	P1 (mm)	W (mm)	Pin1 Quadrant
LM3100MHX	HTSSOP	PWP	20	2500	330.0	16.4	6.95	7.1	1.6	8.0	16.0	Q1
LM3100MHX/NOPB	HTSSOP	PWP	20	2500	330.0	16.4	6.95	7.1	1.6	8.0	16.0	Q1

TAPE AND REEL BOX DIMENSIONS



*All dimensions are nominal

Device	Package Type	Package Drawing	Pins	SPQ	Length (mm)	Width (mm)	Height (mm)
LM3100MHX	HTSSOP	PWP	20	2500	349.0	337.0	45.0
LM3100MHX/NOPB	HTSSOP	PWP	20	2500	349.0	337.0	45.0

IMPORTANT NOTICE

Texas Instruments Incorporated and its subsidiaries (TI) reserve the right to make corrections, enhancements, improvements and other changes to its semiconductor products and services per JESD46, latest issue, and to discontinue any product or service per JESD48, latest issue. Buyers should obtain the latest relevant information before placing orders and should verify that such information is current and complete. All semiconductor products (also referred to herein as "components") are sold subject to TI's terms and conditions of sale supplied at the time of order acknowledgment.

TI warrants performance of its components to the specifications applicable at the time of sale, in accordance with the warranty in TI's terms and conditions of sale of semiconductor products. Testing and other quality control techniques are used to the extent TI deems necessary to support this warranty. Except where mandated by applicable law, testing of all parameters of each component is not necessarily performed.

TI assumes no liability for applications assistance or the design of Buyers' products. Buyers are responsible for their products and applications using TI components. To minimize the risks associated with Buyers' products and applications, Buyers should provide adequate design and operating safeguards.

TI does not warrant or represent that any license, either express or implied, is granted under any patent right, copyright, mask work right, or other intellectual property right relating to any combination, machine, or process in which TI components or services are used. Information published by TI regarding third-party products or services does not constitute a license to use such products or services or a warranty or endorsement thereof. Use of such information may require a license from a third party under the patents or other intellectual property of the third party, or a license from TI under the patents or other intellectual property of TI.

Reproduction of significant portions of TI information in TI data books or data sheets is permissible only if reproduction is without alteration and is accompanied by all associated warranties, conditions, limitations, and notices. TI is not responsible or liable for such altered documentation. Information of third parties may be subject to additional restrictions.

Resale of TI components or services with statements different from or beyond the parameters stated by TI for that component or service voids all express and any implied warranties for the associated TI component or service and is an unfair and deceptive business practice. TI is not responsible or liable for any such statements.

Buyer acknowledges and agrees that it is solely responsible for compliance with all legal, regulatory and safety-related requirements concerning its products, and any use of TI components in its applications, notwithstanding any applications-related information or support that may be provided by TI. Buyer represents and agrees that it has all the necessary expertise to create and implement safeguards which anticipate dangerous consequences of failures, monitor failures and their consequences, lessen the likelihood of failures that might cause harm and take appropriate remedial actions. Buyer will fully indemnify TI and its representatives against any damages arising out of the use of any TI components in safety-critical applications.

In some cases, TI components may be promoted specifically to facilitate safety-related applications. With such components, TI's goal is to help enable customers to design and create their own end-product solutions that meet applicable functional safety standards and requirements. Nonetheless, such components are subject to these terms.

No TI components are authorized for use in FDA Class III (or similar life-critical medical equipment) unless authorized officers of the parties have executed a special agreement specifically governing such use.

Only those TI components which TI has specifically designated as military grade or "enhanced plastic" are designed and intended for use in military/aerospace applications or environments. Buyer acknowledges and agrees that any military or aerospace use of TI components which have **not** been so designated is solely at the Buyer's risk, and that Buyer is solely responsible for compliance with all legal and regulatory requirements in connection with such use.

TI has specifically designated certain components as meeting ISO/TS16949 requirements, mainly for automotive use. In any case of use of non-designated products, TI will not be responsible for any failure to meet ISO/TS16949.

Products

Audio	www.ti.com/audio
Amplifiers	amplifier.ti.com
Data Converters	dataconverter.ti.com
DLP® Products	www.dlp.com
DSP	dsp.ti.com
Clocks and Timers	www.ti.com/clocks
Interface	interface.ti.com
Logic	logic.ti.com
Power Mgmt	power.ti.com
Microcontrollers	microcontroller.ti.com
RFID	www.ti-rfid.com
OMAP Applications Processors	www.ti.com/omap
Wireless Connectivity	www.ti.com/wirelessconnectivity

Applications

Automotive and Transportation	www.ti.com/automotive
Communications and Telecom	www.ti.com/communications
Computers and Peripherals	www.ti.com/computers
Consumer Electronics	www.ti.com/consumer-apps
Energy and Lighting	www.ti.com/energy
Industrial	www.ti.com/industrial
Medical	www.ti.com/medical
Security	www.ti.com/security
Space, Avionics and Defense	www.ti.com/space-avionics-defense
Video and Imaging	www.ti.com/video

TI E2E Community

e2e.ti.com