



National  
Semiconductor  
Corporation

## LM3089 FM Receiver IF System

### General Description

The LM3089 has been designed to provide all the major functions required for modern FM IF designs of automotive, high-fidelity and communications receivers.

### Features

- Three stage IF amplifier/limiter provides 12  $\mu\text{V}$  (typ) -3 dB limiting sensitivity
- Balanced product detector and audio amplifier provide 400 mV (typ) of recovered audio with distortion as low as 0.1% with proper external coil designs.
- Four internal carrier level detectors provide delayed AGC signal to tuner, IF level meter drive current and interchannel mute control
- AFC amplifier provides AFC current for tuner and/or center tuning meters
- Improved operating and temperature performance, especially when using high Q quadrature coils in narrow band FM communications receivers
- No mute circuit latchup problems
- A direct replacement for CA3089E

### Connection Diagram

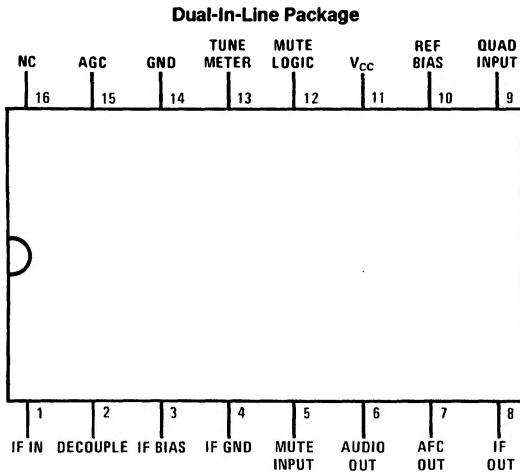

TL/H/7149-2

Top View

Order Number LM3089N  
See NS Package Number N16E

# Block Diagram

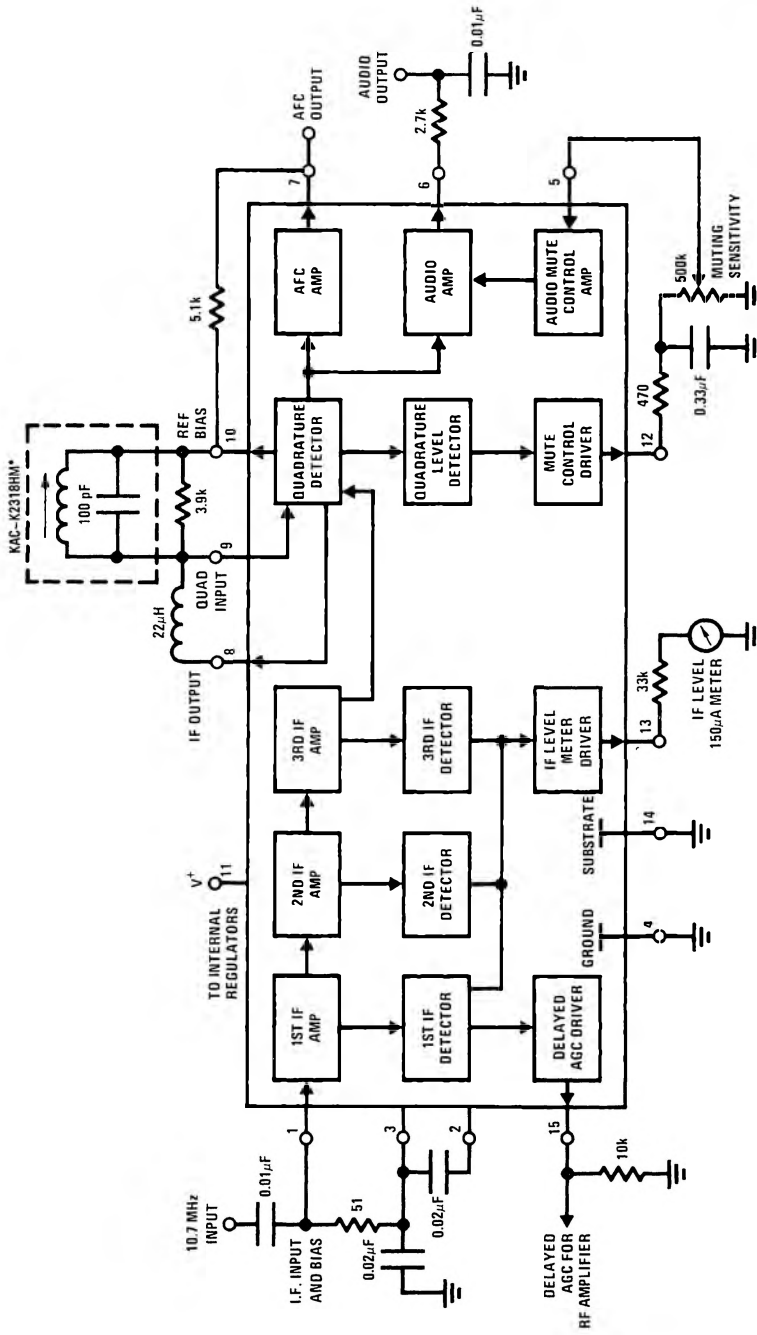

TL/H/7149-1

Toko America  
 1250 Foothill Drive  
 Mount Prospect, IL 60056  
 (312) 297-0070

## Absolute Maximum Ratings

If Military/Aerospace specified devices are required, contact the National Semiconductor Sales Office/Distributors for availability and specifications.

Supply Voltage Between Pin 11 and Pins 4, 14	+16V
DC Current Out of Pin 12	5 mA
DC Current Out of Pin 13	5 mA
DC Current Out of Pin 15	2 mA

Power Dissipation (Note 2)	1500 mW
Operating Temperature Range	-40°C to +85°C
Storage Temperature Range	-65°C to +150°C
Lead Temperature (Soldering, 10 seconds)	260°C

## Electrical Characteristics ( $T_A = 25^\circ\text{C}$ , $V_{CC} = +12\text{V}$ , see Test Circuit)

Symbol	Parameter	Conditions	Min	Typ	Max	Units
<b>DC CHARACTERISTICS (<math>V_{IN} = 0</math>, NOT MUTED)</b>						
$I_{11}$	Supply Current		16	23	30	mA
V1, 2, 3	IF Input and Bias		1.2	1.9	2.4	V
V6	Audio Output		5.0	5.6	6.0	V
V7	AFC Output		5.0	5.6	6.0	V
V10	Reference Bias		5.0	5.6	6.0	V
V12	Mute Control		5.0	5.4	6.0	V
V13	IF Level			0	0.5	V
V15	Delayed AGC		4.2	4.7	5.3	V
<b>DYNAMIC CHARACTERISTICS <math>f_o = 10.7\text{ MHz}</math>, <math>\Delta f = \pm 75\text{ kHz}</math> @ 400 Hz</b>						
$V_{IN}(\text{LIM})$	Input Limiting -3 dB			12	25	$\mu\text{V}$
AMR	AM Rejection	$V_{IN} = 100\text{ mV}$ , AM: 30%	45	55		-dB
$V_O(\text{AF})$	Recovered Audio	$V_{IN} = 10\text{ mV}$	300	400	500	mVrms
THD	Total Harmonic Distortion					
	Single Tuned (Note 1)	$V_{IN} = 100\text{ mV}$		0.5	1.0	%
	Double Tuned (Note 1)	$V_{IN} = 100\text{ mV}$		0.1	0.3	%
S+N/N	Signal to Noise Ratio	$V_{IN} = 100\text{ mV}$	60	70		dB
V12	Mute Control	$V_{IN} = 100\text{ mV}$		0	0.5	V
V13	IF Level	$V_{IN} = 100\text{ mV}$	4.0	5.0	6.0	V
V13	IF Level	$V_{IN} = 500\ \mu\text{V}$	1.0	1.5	2.0	V
V15	Delayed AGC	$V_{IN} = 100\text{ mV}$		0.1	0.5	V
V15	Delayed AGC	$V_{IN} = 30\text{ mV}$		2.5		V
$V_O(\text{AF})$	Audio Muted	$V_{IN} = 100\text{ mV}$ , $V_5 = +2.5\text{V}$		60		-dB

Note 1: Distortion is a function of quadrature coil used.

Note 2: For operation in ambient temperatures above 25°C, the device must be derated based on a 150°C maximum junction temperature and a thermal resistance of 80°C/W junction to ambient.

## Typical Performance Characteristics

Typical S + N/N and IF Limiting Sensitivity vs IF Input Signal

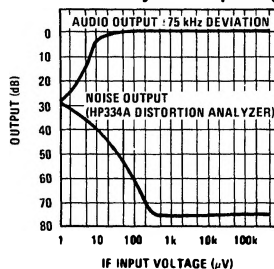

Typical AGC (Pin 15) and Meter Output (Pin 13) vs IF Input Signal

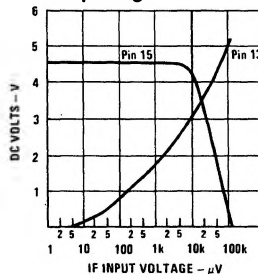

AM Rejection (30% Mod) vs IF Input Signal

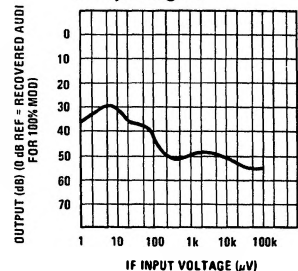

TL/H/7149-3

# Schematic Diagram

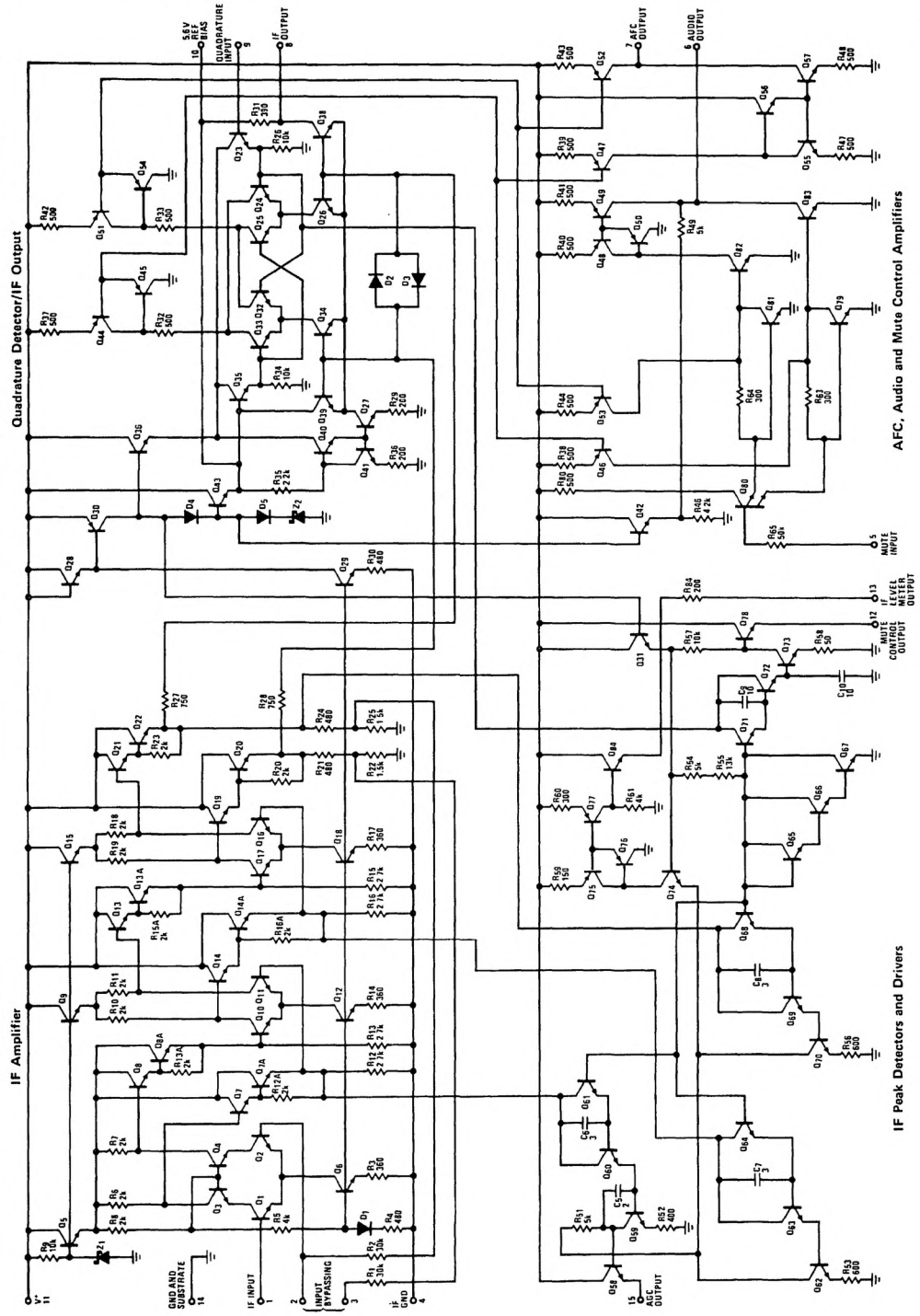

TLH/7149-4

LM3089

# Typical Performance Characteristics

**Supply Current ( $I_{11}$ ) vs Supply Voltage ( $V_{11}$ )**

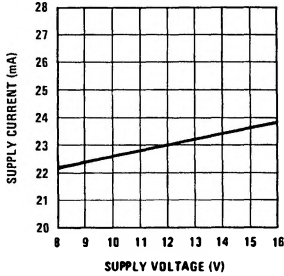

**Reference Voltage, AGC and Meter Output vs Supply Voltage**

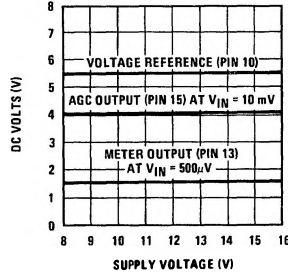

**Mute Control Output (Pin 12) vs IF Input Signal**

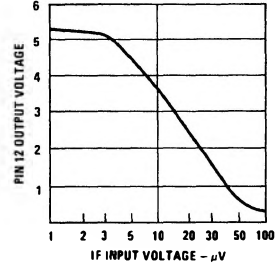

TL/H/7149-5

**Typical Audio Attenuation (Pin 6) vs Mute Input Voltage (Pin 5)**

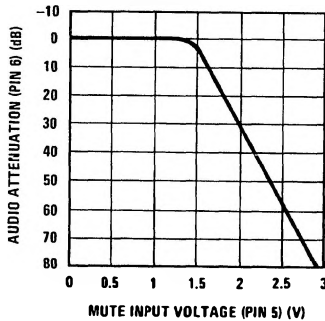

TL/H/7149-6

**DC Test Circuit**

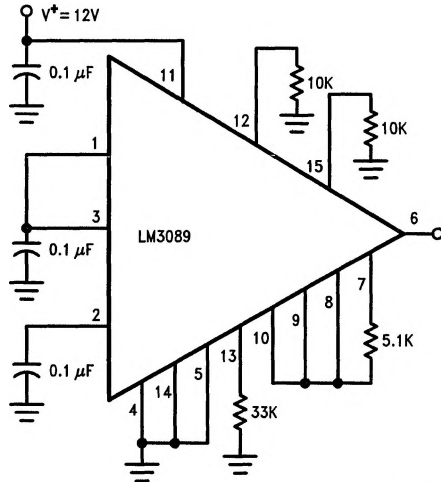

TL/H/7149-7

## AC Test Circuit

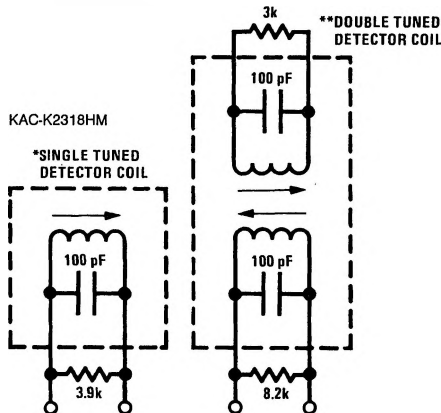

TL/H/7149-8

\*For single tuned detector coil:  
 $L_D$  tunes with 100 pF at 10.7 MHz  
 $Q_{UL}$  (unloaded)  $\approx 75$   
 $Q_L$  (loaded)  $\approx 13$  for  $V_9 \approx 150$  mVrms

\*\*For double tuned detector coil:  
 $Q_{ULPRI} = Q_{ULSEC} \approx 75$   
 $kQ \approx 0.7$  for  $V_9 \approx 150$  mVrms

**Note:**

The recovered audio output voltage will be approximately 0.5 dB less when using the double tuned detector coil.

For proper operation of the mute circuit, the RF voltage at pin 9 should be 150 mVrms  $\pm 30$  mV.

## AC Test Circuit (Continued)

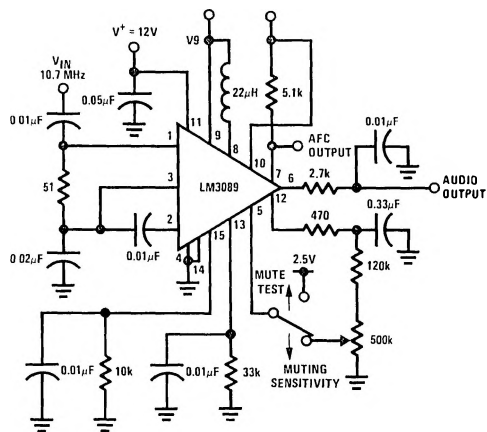

TL/H/7149-9