

LM102/LM302 Voltage Followers

General Description

The LM102 series are high-gain operational amplifiers designed specifically for unity-gain voltage follower applications. Built on a single silicon chip, the devices incorporate advanced processing techniques to obtain very low input current and high input impedance. Further, the input transistors are operated at zero collector-base voltage to virtually eliminate high temperature leakage currents. It can therefore be operated in a temperature stabilized component oven to get extremely low input currents and low offset voltage drift.

The LM102, which is designed to operate with supply voltages between $\pm 12V$ and $\pm 15V$, also features low input capacitance as well as excellent small signal and large signal frequency response—all of which minimize high fre-

quency gain error. Because of the low wiring capacitances inherent in monolithic construction, this fast operation can be realized without increasing power consumption.

Features

- Fast slewing — $10V/\mu s$
- Low input current — 10 nA (max)
- High input resistance — 10,000 M Ω
- No external frequency compensation required
- Simple offset balancing with optional 1 k Ω potentiometer
- Plug-in replacement for both the LM101 and LM709 in voltage follower applications

Schematic Diagram

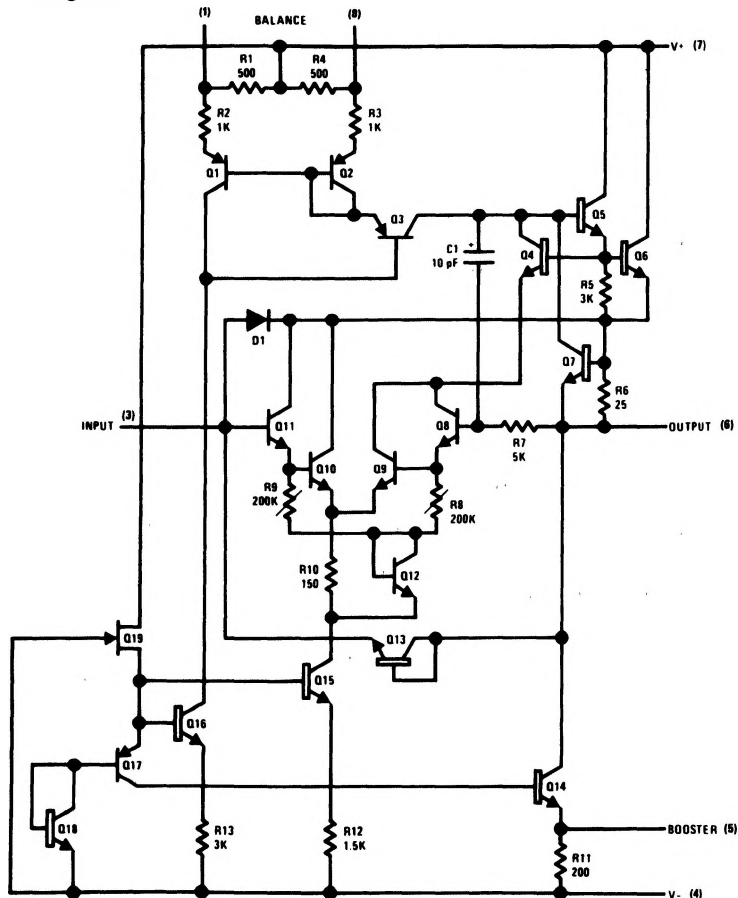

TL/H/7753-1

Absolute Maximum Ratings

If Military/Aerospace specified devices are required, please contact the National Semiconductor Sales Office/Distributors for availability and specifications. (Note 6)

Supply Voltage	±18V
Power Dissipation (Note 1)	500 mW
Input Voltage (Note 2)	±15V
Output Short Circuit Duration (Note 3)	Indefinite

Operating Free Air Temperature Range	
LM102	-55°C to +125°C
LM302	0°C to +70°C
Storage Temperature Range	-65°C to +150°C
Lead Temperature (Soldering, 10 sec.)	300°C
ESD rating to be determined.	

Electrical Characteristics (Note 4)

Parameter	Conditions	LM102			LM302			Units
		Min	Typ	Max	Min	Type	Max	
Input Offset Voltage	$T_A = 25^\circ\text{C}$		2	5		5	15	mV
Input Bias Current	$T_A = 25^\circ\text{C}$		3	10		10	30	nA
Input Resistance	$T_A = 25^\circ\text{C}$	10^{10}	10^{12}		10^9	10^{12}		Ω
Input Capacitance				3.0		3.0		pF
Large Signal Voltage Gain	$T_A = 25^\circ\text{C}$, $V_S \pm 15\text{V}$, $V_{OUT} = \pm 10\text{V}$, $R_L = 8\text{ k}\Omega$	0.999	0.9996		0.9985	0.9995	1.0	V/V
Output Resistance	$T_A = 25^\circ\text{C}$		0.8	2.5		0.8	2.5	Ω
Supply Current	$T_A = 25^\circ\text{C}$		3.5	5.5		3.5	5.5	mA
Input Offset Voltage				7.5			20	mV
Offset Voltage Temperature Drift			6			20		$\mu\text{V}/^\circ\text{C}$
Input Bias Current	$T_A = T_{A\text{MAX}}$ $T_A = T_{A\text{MIN}}$		3 30	10 100		3.0 20	15 50	nA nA
Large Signal Voltage Gain	$V_S = \pm 15\text{V}$, $V_{OUT} = \pm 10\text{V}$, $R_L = 10\text{ k}\Omega$	0.999						
Output Voltage Swing	$V_S = \pm 15\text{V}$, $R_L = 10\text{ k}\Omega$ (Note 5)	±10			±10			V
Supply Current	$T_A = 125^\circ\text{C}$		2.6	4.0				mA
Supply Voltage Rejection Ratio	$\pm 12\text{V} \leq V_S \leq \pm 15\text{V}$	60			60			dB

Note 1: The maximum junction temperature of the LM102 is 150°C, while that of the LM302 is 85°C. For operating at elevated temperatures, devices in the H08 package must be derated based on a thermal resistance of 150°C/W, junction to ambient, or 20°C/W, junction to case.

Note 2: For supply voltages less than ±15V, the absolute maximum input voltage is equal to the supply voltage.

Note 3: It is necessary to insert a resistor (at least 5k and preferably 10k) in series with the input pin when the amplifier is driven from low impedance sources to prevent damage when the output is shorted and to ensure stability.

Note 4: These specifications apply for $\pm 12\text{V} \leq V_S \leq \pm 15\text{V}$ and $-55^\circ\text{C} \leq T_A \leq 125^\circ\text{C}$ for the LM102 and $0^\circ\text{C} \leq T_A \leq 70^\circ\text{C}$ for the LM302 unless otherwise specified.

Note 5: Increased output swing under load can be obtained by connecting an external resistor between the booster and V^- terminals. See curve.

Note 6: Refer to RETS102X for the LM102H military specifications.

APPLICATION HINT

The input must be driven from a source impedance of typically 10 k Ω (5 k Ω Min) to maintain stability. The total source impedance will be reduced at high frequencies if there is stray capacitance at the input pin. In these cases, a 10 k Ω resistor should be inserted in series with the input, physically close to the input pin to minimize the stray capacitance and prevent oscillation.

Guaranteed Performance Characteristics LM102

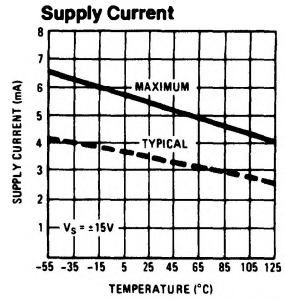
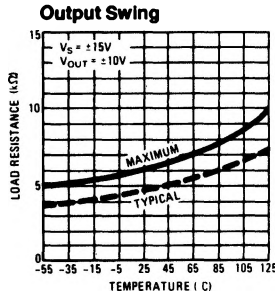
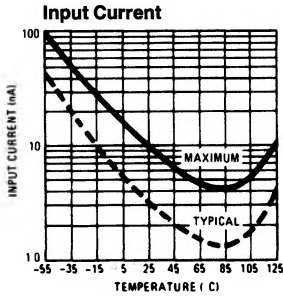

TL/H/7753-7

Typical Performance Characteristics LM102

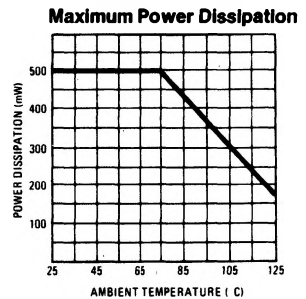
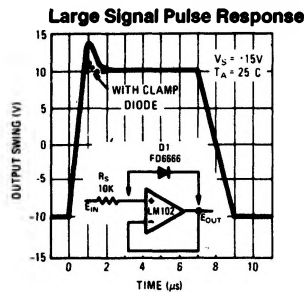
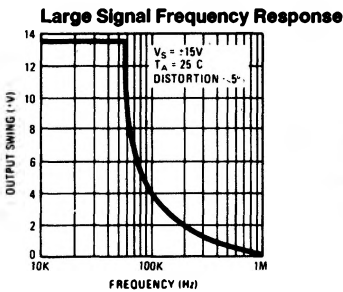
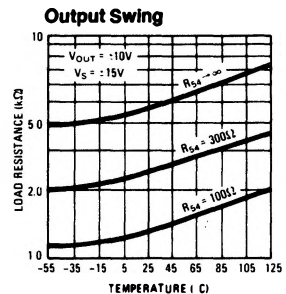
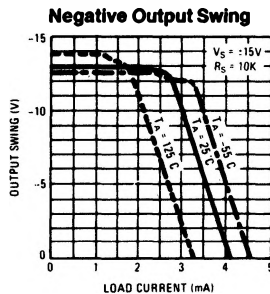
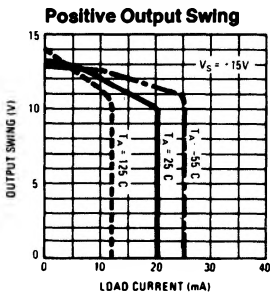
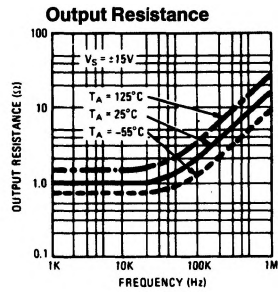
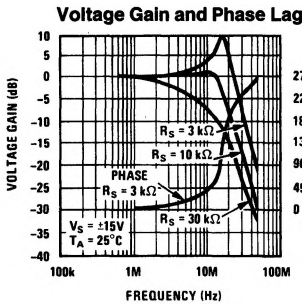
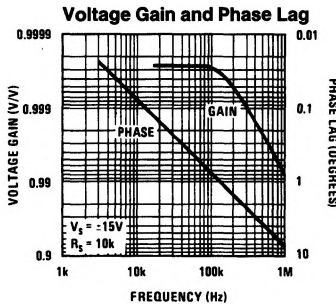

TL/H/7753-8

Guaranteed Performance Characteristics LM302

Input Current

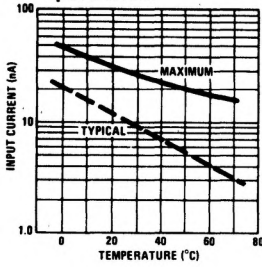

Output Swing

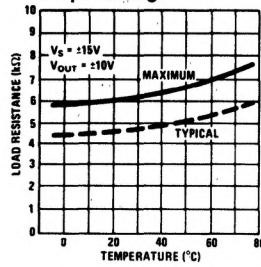

Supply Current

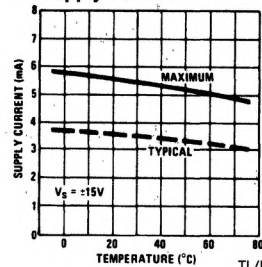

TL/H/7753-9

Typical Performance Characteristics LM302

Voltage Gain and Phase Lag

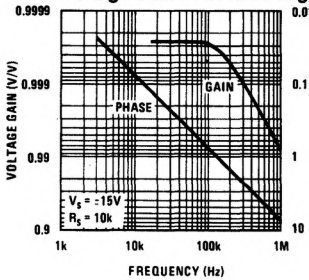

Voltage Gain and Phase Lag

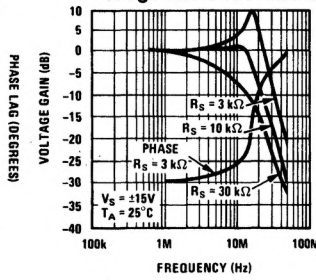

Output Resistance

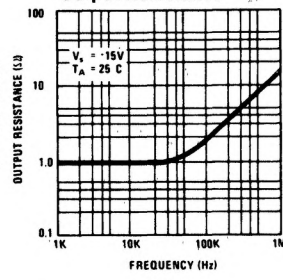

Positive Output Swing

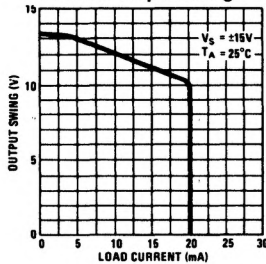

Negative Output Swing

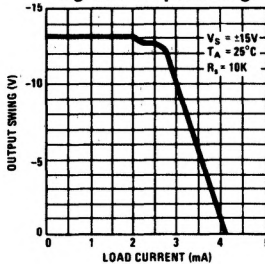

Output Swing

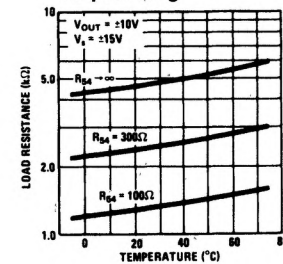

Large Signal Frequency Response

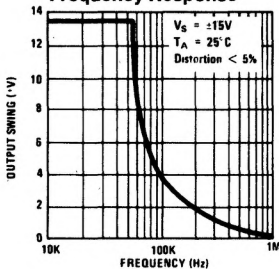

Large Signal Pulse Response

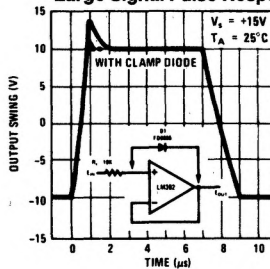

Maximum Power Dissipation

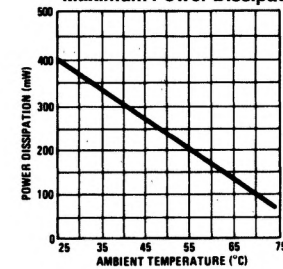

TL/H/7753-10

Typical Applications

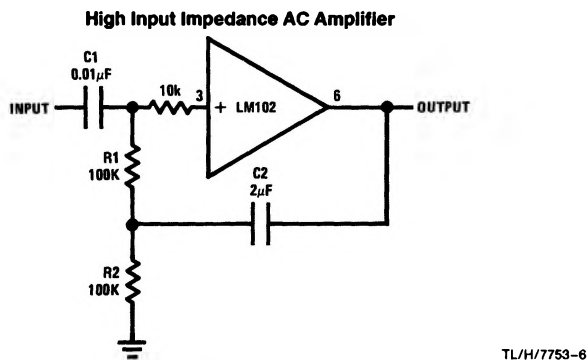
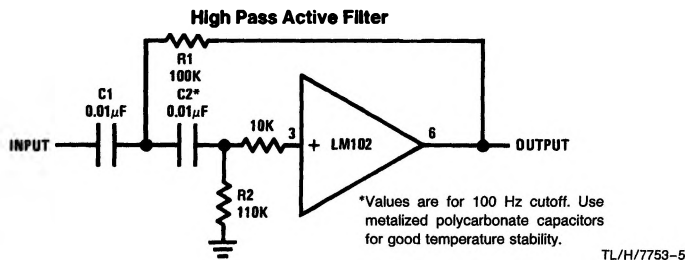
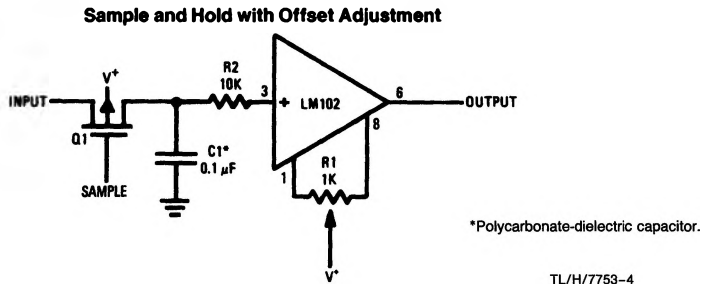
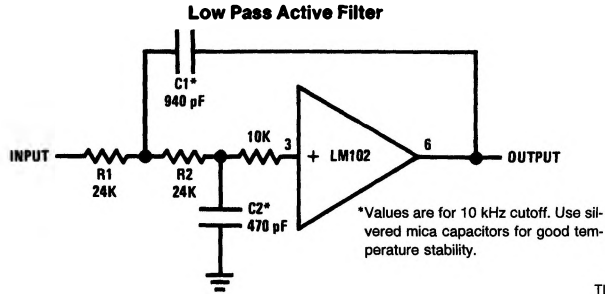

Connection Diagram

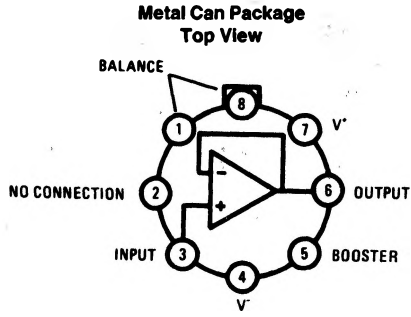

TL/H/7753-2

**Order Number LM102H/883
See NS Package Number H08C**