

LM301A, LM201A

Non Compensated Single Operational Amplifiers

A general purpose operational amplifier that allows the user to choose the compensation capacitor best suited to his needs. With proper compensation, summing amplifier slew rates to 10 V/ μ s can be obtained.

- Low Input Offset Current: 20 nA Maximum Over Temperature Range
- External Frequency Compensation for Flexibility
- Class AB Output Provides Excellent Linearity
- Output Short Circuit Protection
- Guaranteed Drift Characteristics

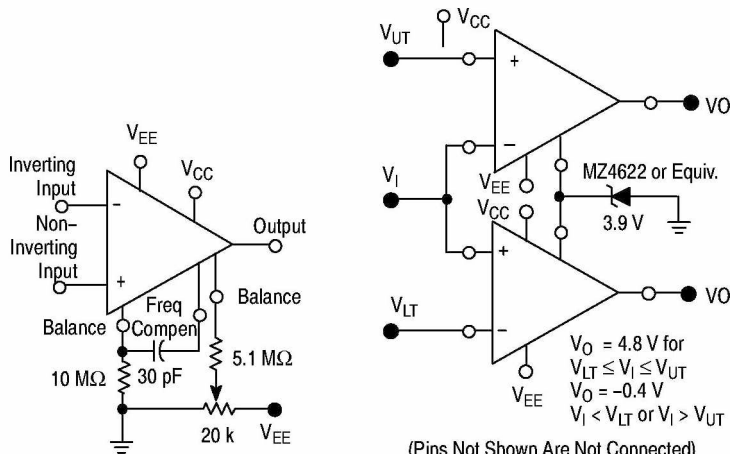
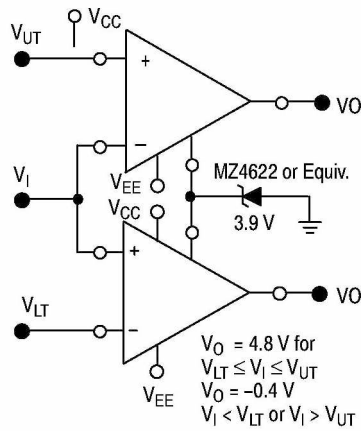

Figure 1. Standard Compensation and Offset Balancing Circuit



(Pins Not Shown Are Not Connected)

Figure 2. Double-Ended Limit Detector

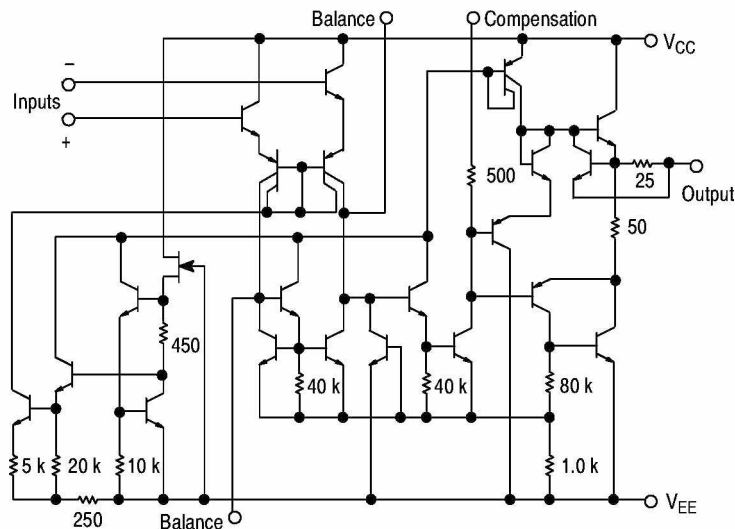

Figure 3. Representative Circuit Schematic



ON Semiconductor™

<http://onsemi.com>

MARKING DIAGRAMS

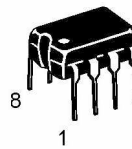

PDIP-8
N SUFFIX
CASE 626

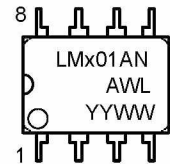

SO-8
D SUFFIX
CASE 751

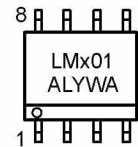

x = 2 or 3
A = Assembly Location
WL, L = Wafer Lot
YY, Y = Year
WW, W = Work Week

PIN CONNECTIONS

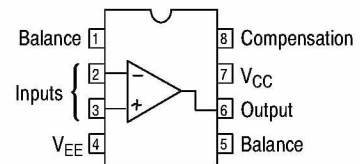

(Top View)

ORDERING INFORMATION

Device	Package	Shipping
LM301AD	SO-8	98 Units/Rail
LM301ADR2	SO-8	2500 Tape & Reel
LM301AN	PDIP-8	50 Units/Rail
LM201AD	SO-8	98 Units/Rail
LM201ADR2	SO-8	2500 Tape & Reel
LM201AN	PDIP-8	50 Units/Rail

LM301A, LM201A

MAXIMUM RATINGS

Rating	Symbol	Value		Unit
		LM201A	LM301A	
Power Supply Voltage	V_{CC}, V_{EE}	±22	±18	Vdc
Input Differential Voltage	V_{ID}	← ±30 →		V
Input Common Mode Range (Note 1)	V_{ICR}	← ±15 →		V
Output Short Circuit Duration	t_{SC}	← Continuous →		
Power Dissipation (Package Limitation) Plastic Dual-In-Line Package Derate above $T_A = +25^\circ\text{C}$	P_D	625 5.0	625 5.0	mW mW/°C
Operating Ambient Temperature Range	T_A	-25 to +85	0 to +70	°C
Storage Temperature Range	T_{stg}	← -65 to +150 →		°C

ELECTRICAL CHARACTERISTICS ($T_A = +25^\circ\text{C}$, unless otherwise noted.) Unless otherwise specified, these specifications apply for supply voltages from ±5.0 V to ±20 V for the LM201A, and from ±5.0 V to ±15 V for the LM301A.

Characteristic	Symbol	LM201A			LM301A			Unit
		Min	Typ	Max	Min	Typ	Max	
Input Offset Voltage ($R_S \leq 50\text{ k}\Omega$)	V_{IO}	-	0.7	2.0	-	2.0	7.5	mV
Input Offset Current	I_{IO}	-	1.5	10	-	3.0	50	nA
Input Bias Current	I_{IB}	-	30	75	-	70	250	nA
Input Resistance	r_i	1.5	4.0	-	0.5	2.0	-	MΩ
Supply Current $V_{CC}/V_{EE} = \pm 20\text{ V}$ $V_{CC}/V_{EE} = \pm 15\text{ V}$	I_{CC}, I_{EE}	-	1.8	3.0	-	-	-	mA
Large Signal Voltage Gain ($V_{CC}/V_{EE} = \pm 15\text{ V}$, $V_O = \pm 10\text{ V}$, $R_L > 2.0\text{ k}\Omega$)	A_V	50	160	-	25	160	-	V/mV

The following specifications apply over the operating temperature range.

Input Offset Voltage ($R_S \leq 50\text{ k}\Omega$)	V_{IO}	-	-	3.0	-	-	10	mV
Input Offset Current	I_{IO}	-	-	20	-	-	70	nA
Avg Temperature Coefficient of Input Offset Voltage (Note 2) $T_A(\text{min}) \leq T_A \leq T_A(\text{max})$	$\Delta V_{IO}/\Delta T$	-	3.0	15	-	6.0	30	$\mu\text{V}/^\circ\text{C}$
Avg Temperature Coefficient of Input Offset Current (Note 2) $+25^\circ\text{C} \leq T_A \leq T_A(\text{max})$ $T_A(\text{min}) \leq T_A \leq 25^\circ\text{C}$	$\Delta I_{IO}/\Delta T$	-	0.01 0.02	0.1 0.2	-	0.01 0.02	0.3 0.6	nA/°C
Input Bias Current	I_{IB}	-	-	100	-	-	300	nA
Large Signal Voltage Gain ($V_{CC}/V_{EE} = \pm 15\text{ V}$, $V_O = \pm 10\text{ V}$, $R_L > 2.0\text{ k}\Omega$)	A_{VOL}	25	-	-	15	-	-	V/mV
Input Voltage Range $V_{CC}/V_{EE} = \pm 20\text{ V}$ $V_{CC}/V_{EE} = \pm 15\text{ V}$	V_{ICR}	-15 -	- -	+15 -	- -12	- -	- +12	V
Common Mode Rejection ($R_S \leq 50\text{ k}\Omega$)	CMR	80	96	-	70	90	-	dB
Supply Voltage Rejection ($R_S \leq 50\text{ k}\Omega$)	PSR	80	96	-	70	96	-	dB
Output Voltage Swing ($V_{CC}/V_{EE} = \pm 15\text{ V}$, $R_L = \pm 10\text{ k}\Omega$, $R_L > 2.0\text{ k}\Omega$)	V_O	±12 ±10	±14 ±13	- -	±12 ±10	±14 ±13	- -	V
Supply Currents ($T_A = T_A(\text{max})$, $V_{CC}/V_{EE} = \pm 20\text{ V}$)	I_{CC}, I_{EE}	-	1.2	2.5	-	-	-	mA

- For supply voltages less than ±15 V, the absolute maximum input voltage is equal to the supply voltage.
- Guaranteed by design.

LM301A, LM201A

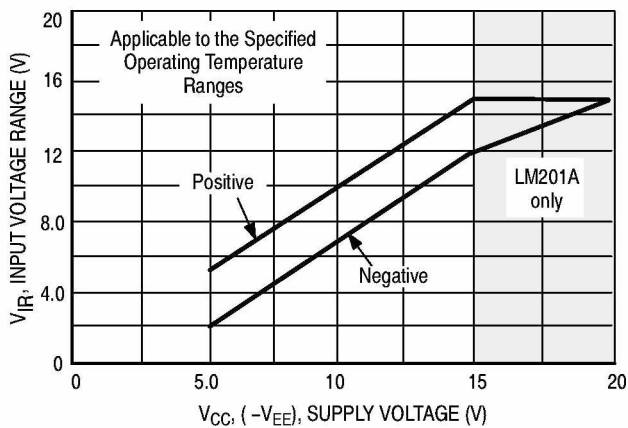

Figure 4. Minimum Input Voltage Range

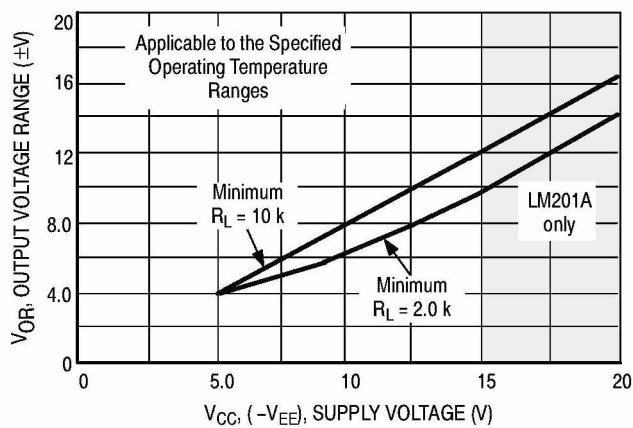

Figure 5. Minimum Output Voltage Swing

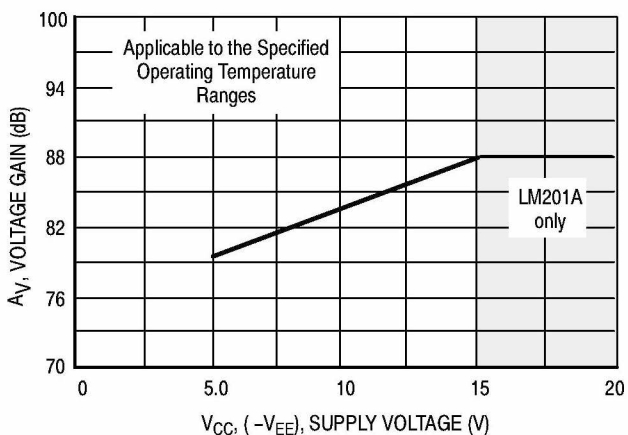

Figure 6. Minimum Voltage Gain

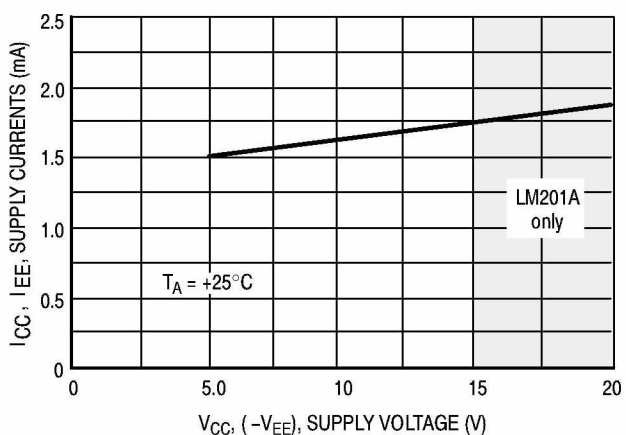

Figure 7. Typical Supply Currents

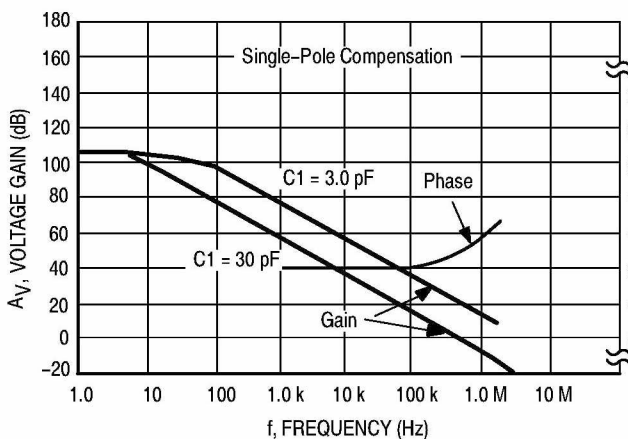

Figure 8. Open Loop Frequency Response

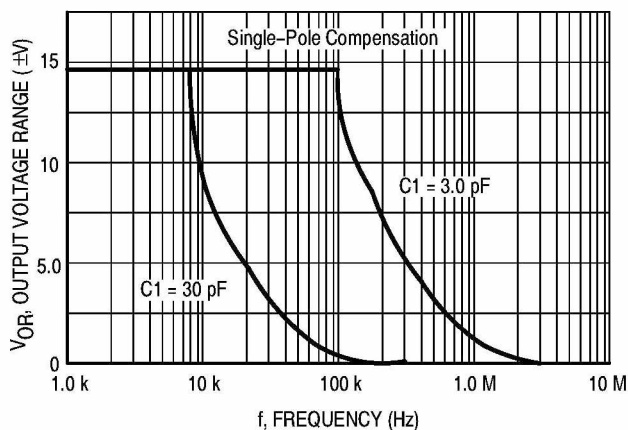

Figure 9. Large Signal Frequency Response

LM301A, LM201A

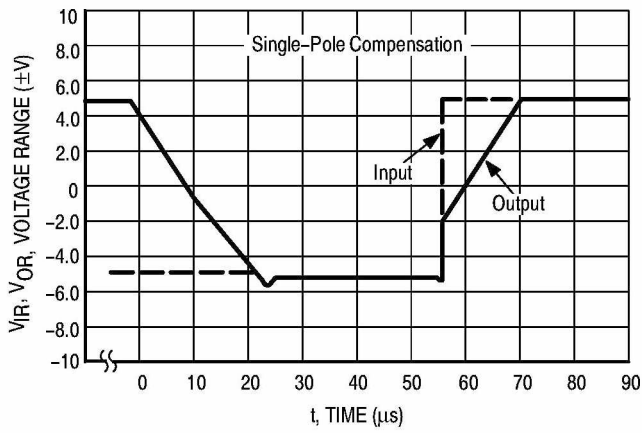

Figure 10. Voltage Follower Pulse Response

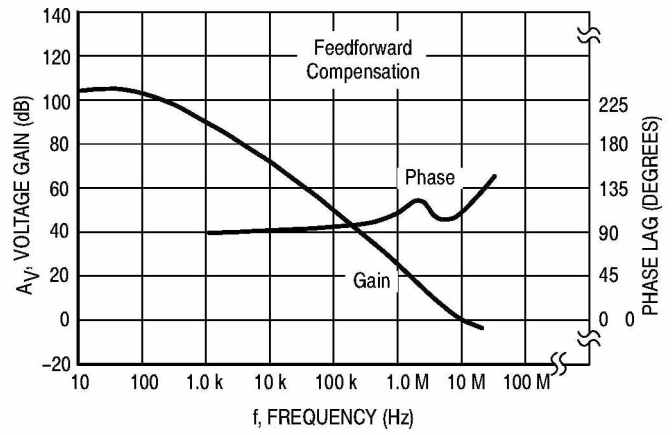

Figure 11. Open Loop Frequency Response

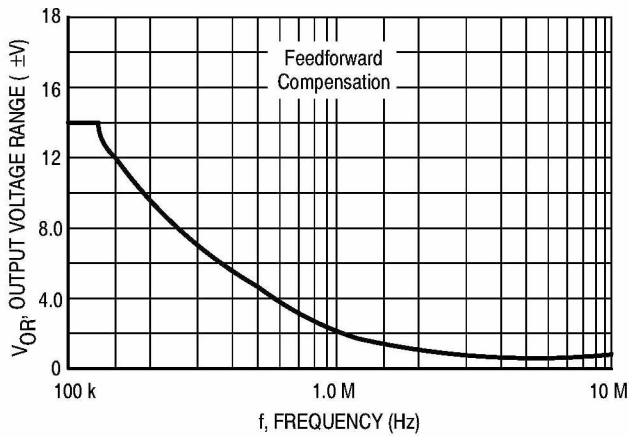

Figure 12. Large Signal Frequency Response

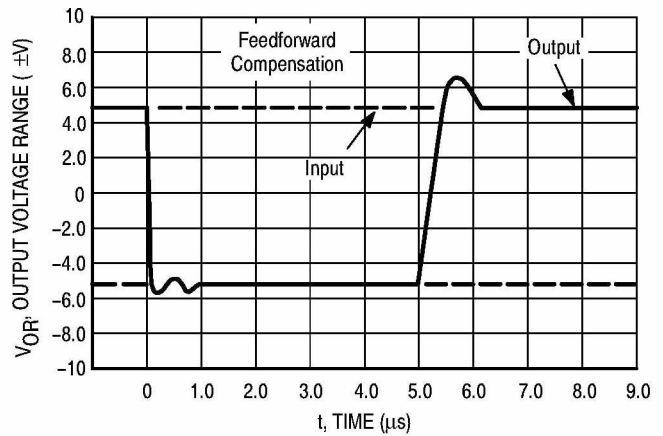

Figure 13. Inverter Pulse Response

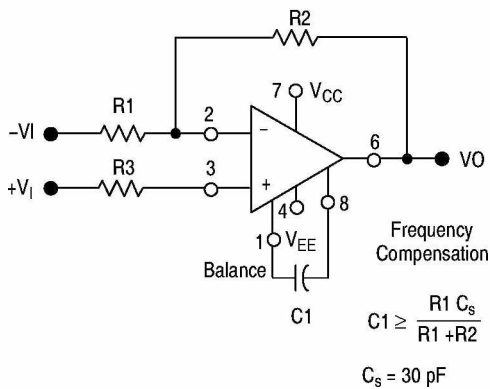

Figure 14. Single-Pole Compensation

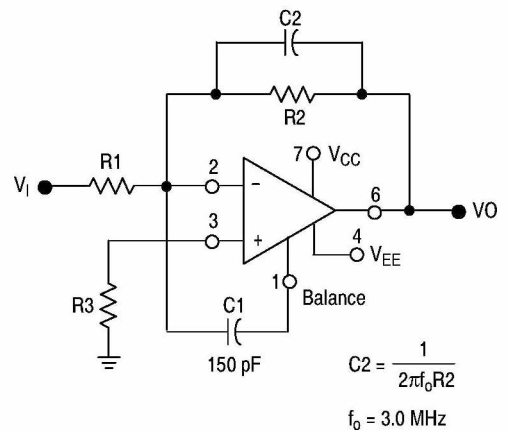

Figure 15. Feedforward Compensation