



LM1896/LM2896 Dual Audio Power Amplifier

General Description

The LM1896 is a high performance 6V stereo power amplifier designed to deliver 1 watt/channel into 4Ω or 2 watts bridged monaural into 8Ω . Utilizing a unique patented compensation scheme, the LM1896 is ideal for sensitive AM radio applications. This new circuit technique exhibits lower wideband noise, lower distortion, and less AM radiation than conventional designs. The amplifier's wide supply range (3V–9V) is ideal for battery operation. For higher supplies ($V_S > 9V$) the LM2896 is available in an 11-lead single-in-line package. The LM2896 package has been redesigned, resulting in the slightly degraded thermal characteristics shown in the figure Device Dissipation vs Ambient Temperature.

Features

- Low AM radiation
- Low noise
- 3V, 4Ω , stereo $P_o = 250\text{ mW}$
- Wide supply operation 3V–15V (LM2896)
- Low distortion
- No turn on "pop"
- Adjustable voltage gain and bandwidth
- Smooth waveform clipping
- $P_o = 9W$ bridged, LM2896

Applications

- Compact AM-FM radios
- Stereo tape recorders and players
- High power portable stereos

Typical Applications

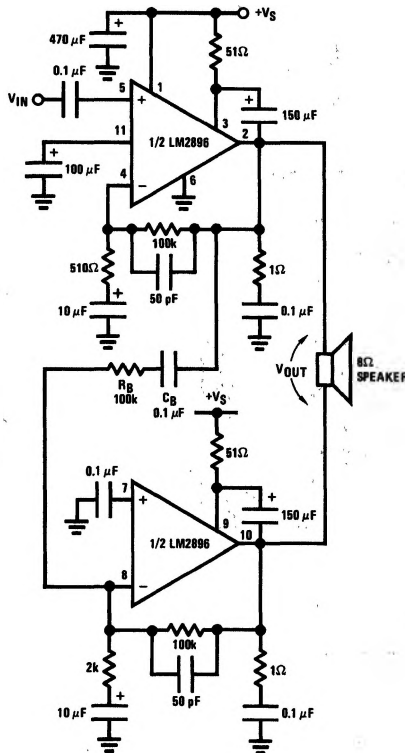

TL/H/7920-1

FIGURE 1. LM2896 in Bridge Configuration ($A_v = 400$, $BW = 20\text{ kHz}$)

Order Number LM1896N
See NS Package Number N14A

Order Number LM2896P
See NS Package Number P11A

Absolute Maximum Ratings

If Military/Aerospace specified devices are required, please contact the National Semiconductor Sales Office/Distributors for availability and specifications.

Supply Voltage	
LM1896	$V_S = 12V$
LM2896	$V_S = 18V$
Operating Temperature (Note 1)	$0^\circ C$ to $+70^\circ C$
Storage Temperature	$-65^\circ C$ to $+150^\circ C$

Junction Temperature	$150^\circ C$
Lead Temperature (Soldering, 10 sec.)	$260^\circ C$
Thermal Resistance	
θ_{JC} (DIP)	$30^\circ C/W$
θ_{JA} (DIP)	$137^\circ C/W$
θ_{JC} (SIP)	$10^\circ C/W$
θ_{JA} (SIP)	$55^\circ C/W$

Electrical Characteristics

Unless otherwise specified, $T_A = 25^\circ C$, $A_V = 200$ (46 dB). For the LM1896; $V_S = 6V$ and $R_L = 4\Omega$. For LM2896, $T_{TAB} = 25^\circ C$, $V_S = 12V$ and $R_L = 8\Omega$. Test circuit shown in Figure 2.

Parameter	Conditions	LM1896			LM2896			Units	
		Min	Typ	Max	Min	Typ	Max		
Supply Current	$P_O = 0W$, Dual Mode		15	25		25	40	mA	
Operating Supply Voltage		3		10	3		15	V	
Output Power	THD = 10%, $f = 1$ kHz								
LM1896N-1	$V_S = 6V$, $R_L = 4\Omega$ Dual Mode	0.9	1.1	2.1	2.0	2.5		W/ch	
LM1896N-2	$V_S = 6V$, $R_L = 8\Omega$ Bridge Mode							1.8	W
LM2896P-1	$V_S = 9V$, $R_L = 8\Omega$ Dual Mode							1.3	W/ch
LM2896P-2	$V_S = 12V$, $R_L = 8\Omega$ Dual Mode				7.2	9.0		W	
	$V_S = 12V$, $R_L = 8\Omega$ Bridge Mode					7.8		W	
	$V_S = 9V$, $R_L = 4\Omega$ Bridge Mode					2.5		W/ch	
	$V_S = 9V$, $R_L = 4\Omega$ Dual Mode							W/ch	
Distortion	$f = 1$ kHz $P_O = 50$ mW $P_O = 0.5W$ $P_O = 1W$		0.09 0.11			0.09 0.11 0.14		% % %	
Power Supply Rejection Ratio (PSRR)	$C_{BY} = 100 \mu F$, $f = 1$ kHz, $C_{IN} = 0.1 \mu F$ Output Referred, $V_{RIPPLE} = 250$ mV	-40	-54		-40	-54		dB	
Channel Separation	$C_{BY} = 100 \mu F$, $f = 1$ kHz, $C_{IN} = 0.1 \mu F$ Output Referred	-50	-64		-50	-64		dB	
Noise	Equivalent Input Noise $R_S = 0$, $C_{IN} = 0.1 \mu F$, BW = 20 - 20 kHz CCIR/ARM Wideband		1.4 1.4 2.0			1.4 1.4 2.0		μV μV μV	
DC Output Level		2.8	3	3.2	5.6	6	6.4	V	
Input Impedance		50	100	350	50	100	350	k Ω	
Input Offset Voltage			5			5		mV	
Voltage Difference between Outputs	LM1896N-2, LM2896P-2		10	20		10	20	mV	
Input Bias Current			120			120		nA	

Note 1: For operation at ambient temperature greater than $25^\circ C$, the LM1896/LM2896 must be derated based on a maximum $150^\circ C$ junction temperature using a thermal resistance which depends upon mounting techniques.

Typical Performance Curves

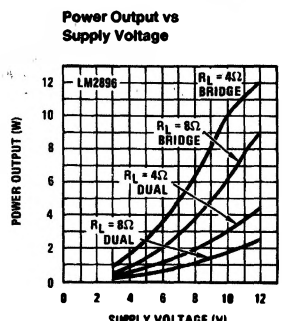
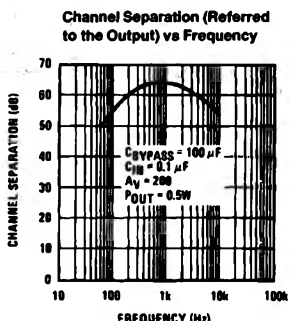
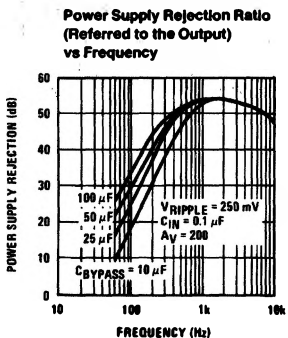
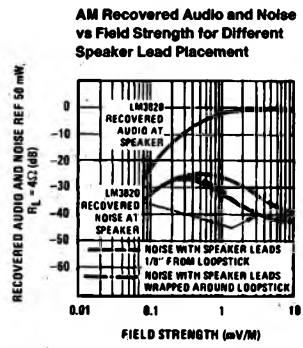
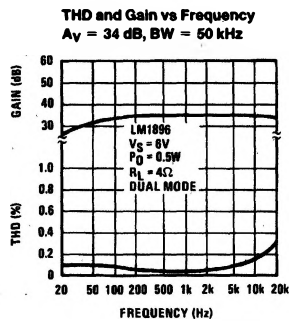
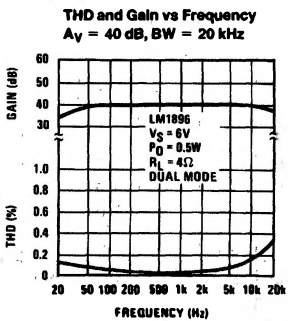
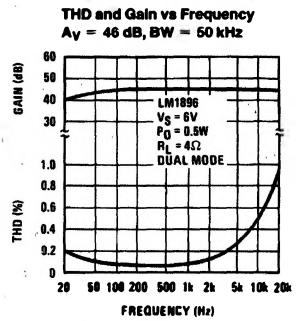
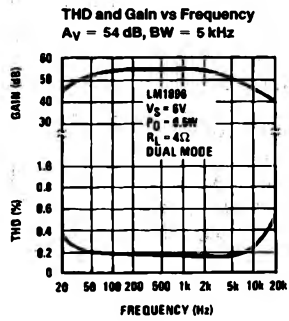
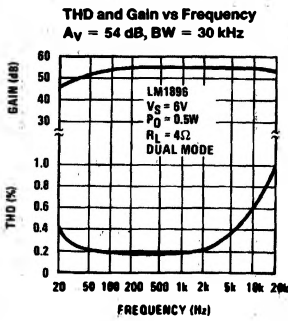
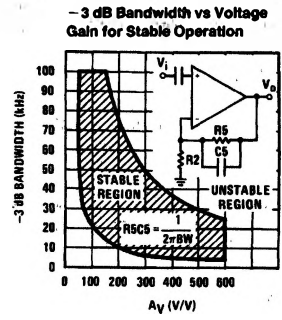
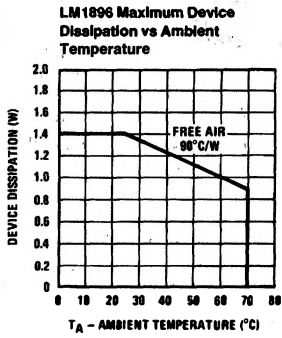
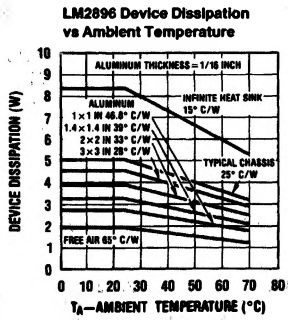

Typical Performance Curves (Continued)

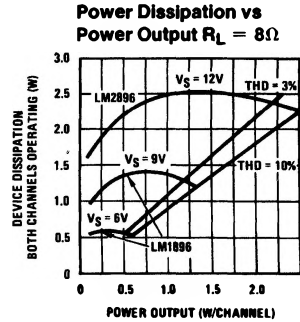
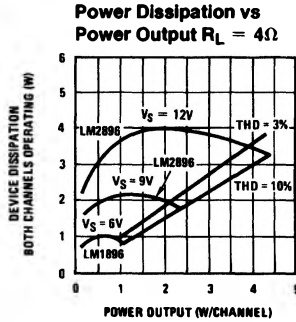
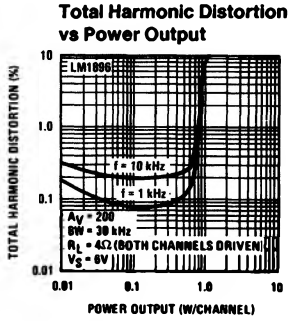

TL/H/7920-3

Equivalent Schematic

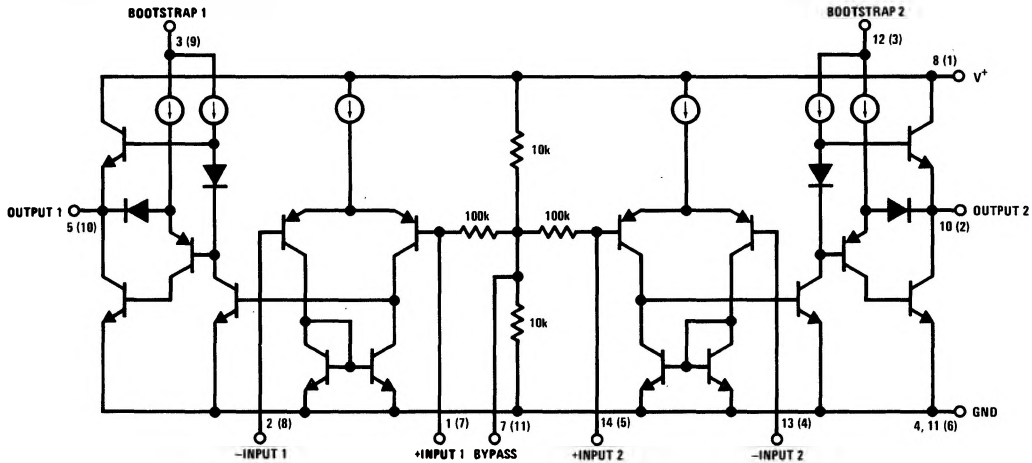

6, 9 No connection on LM1896
 () indicates pin number for LM2896

TL/H/7920-4

Connection Diagrams

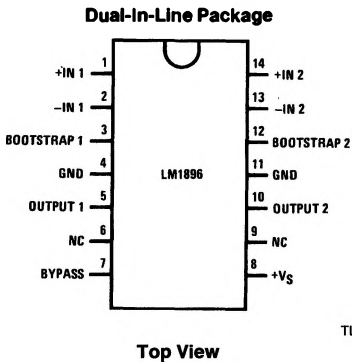

TL/H/7920-5

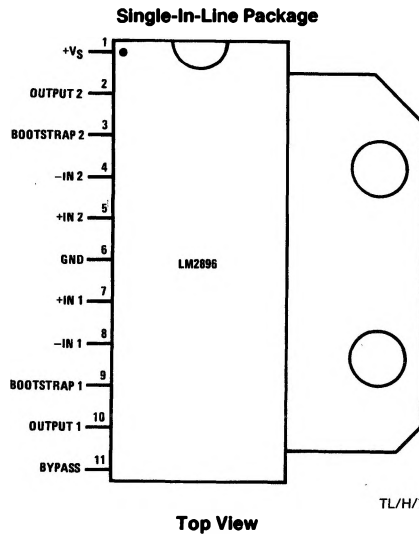

TL/H/7920-6

Typical Applications (Continued)

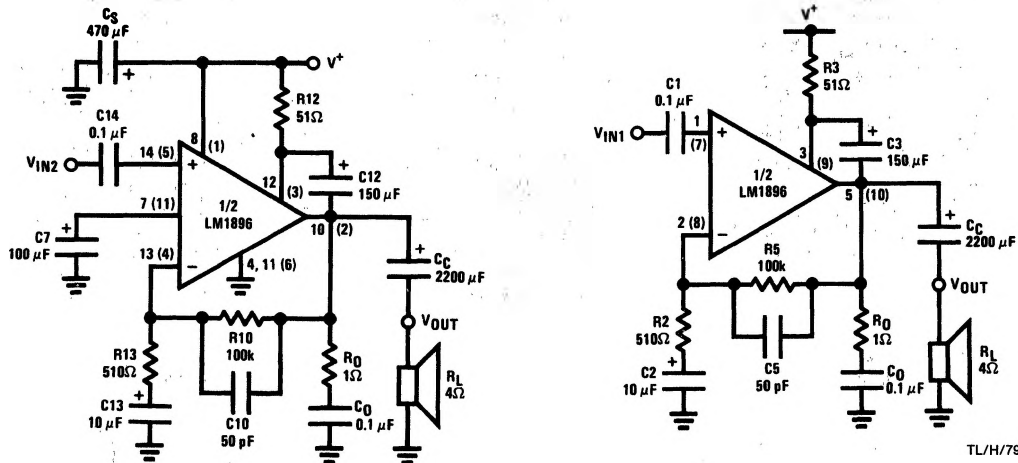

TL/H/7920-8

6, 9 No connection on LM1896.

() Indicates pin number for LM2896

FIGURE 2. Stereo Amplifier with $A_V = 200$, $BW = 30$ kHz

External Components (Figure 2)

Components	Comments
1. R2, R5, R10, R13	Sets voltage gain, $A_V = 1 + R5/R2$ for one channel and $A_V = 1 + R10/R13$ for the other channel.
2. R3, R12	Bootstrap resistor sets drive current for output stage and allows pins 3 and 12 to go above V_S .
3. R0	Works with C_C to stabilize output stage.
4. C1, C14	Input coupling capacitor. Pins 1 and 14 are at a DC potential of $V_S/2$. Low frequency pole set by: $f_L = \frac{1}{2\pi R_{IN} C1}$
5. C2, C13	Feedback capacitors. Ensure unity gain at DC. Also a low frequency pole at: $f_L = \frac{1}{2\pi R2 C2}$
6. C3, C12	Bootstrap capacitors, used to increase drive to output stage. A low frequency pole is set by: $f_L = \frac{1}{2\pi R3 C3}$
7. C5, C10	Compensation capacitor. These stabilize the amplifiers and adjust their bandwidth. See curve of bandwidth vs allowable gain.
8. C7	Improves power supply rejection (See Typical Performance Curves). Increasing C7 increases turn-on delay.
9. Cc	Output coupling capacitor. Isolates pins 5 and 10 from the load. Low frequency pole set by: $f_L = \frac{1}{2\pi Cc R_L}$
10. C0	Works with R0 to stabilize output stage.
11. Cs	Provides power supply filtering.

Application Hints

AM Radios

The LM1896/LM2896 has been designed to fill a wide range of audio power applications. A common problem with IC audio power amplifiers has been poor signal-to-noise performance when used in AM radio applications. In a typical radio application, the loopstick antenna is in close proximity to the audio amplifier. Current flowing in the speaker and power supply leads can cause electromagnetic coupling to the loopstick, resulting in system oscillation. In addition, most audio power amplifiers are not optimized for lowest noise because of compensation requirements. If noise from the audio amplifier radiates into the AM section, the sensitivity and signal-to-noise ratio will be degraded.

The LM1896 exhibits extremely low wideband noise due in part to an external capacitor C5 which is used to tailor the bandwidth. The circuit shown in *Figure 2* is capable of a signal-to-noise ratio in excess of 60 dB referred to 50 mW. Capacitor C5 not only limits the closed loop bandwidth, it also provides overall loop compensation. Neglecting C2 in *Figure 2*, the gain is:

$$A_V(S) = \frac{S + A_V \omega_0}{S + \omega_0}$$

$$\text{where } A_V = \frac{R_2 + R_5}{R_2}, \quad \omega_0 = \frac{1}{R_5 C_5}$$

A curve of -3 dB BW (ω_0) vs A_V is shown in the Typical Performance Curves.

Figure 3 shows a plot of recovered audio as a function of field strength in $\mu\text{V}/\text{M}$. The receiver section in this example is an LM3820. The power amplifier is located about two inches from the loopstick antenna. Speaker leads run parallel to the loopstick and are $1/8$ inch from it. Referred to a 20 dB S/N ratio, the improvement in noise performance over conventional designs is about 10 dB. This corresponds to an increase in usable sensitivity of about 8.5 dB.

Bridge Amplifiers

The LM1896/LM2896 can be used in the bridge mode as a monaural power amplifier. In addition to much higher power output, the bridge configuration does not require output coupling capacitors. The load is connected directly between the amplifier outputs as shown in *Figure 4*.

Amp 1 has a voltage gain set by $1 + R_5/R_2$. The output of amp 1 drives amp 2 which is configured as an inverting amplifier with unity gain. Because of this phase inversion in amp 2, there is a 6 dB increase in voltage gain referenced to V_i . The voltage gain in bridge is:

$$\frac{V_o}{V_i} = 2 \left(1 + \frac{R_5}{R_2} \right)$$

C_B is used to prevent DC voltage on the output of amp 1 from causing offset in amp 2. Low frequency response is influenced by:

$$f_L = \frac{1}{2\pi R_B C_B}$$

Several precautions should be observed when using the LM1896/LM2896 in bridge configuration. Because the amplifiers are driving the load out of phase, an 8Ω speaker will appear as a 4Ω load, and a 4Ω speaker will appear as a 2Ω load. Power dissipation is twice as severe in this situation. For example, if $V_S = 6\text{V}$ and $R_L = 8\Omega$ bridged, then the maximum dissipation is:

$$P_D = \frac{V_S^2}{20 R_L} \times 2 = \frac{6^2}{20 \times 4} \times 2$$

$$P_D = 0.9 \text{ Watts}$$

This amount of dissipation is equivalent to driving two 4Ω loads in the stereo configuration.

When adjusting the frequency response in the bridge configuration, $R_5 C_5$ and $R_{10} C_{10}$ form a 2 pole cascade and the -3 dB bandwidth is actually shifted to a lower frequency:

$$BW = \frac{0.707}{2\pi RC}$$

where R = feedback resistor

C = feedback capacitor

To measure the output voltage, a floating or differential meter should be used because a prolonged output short will over dissipate the package. *Figure 1* shows the complete bridge amplifier.

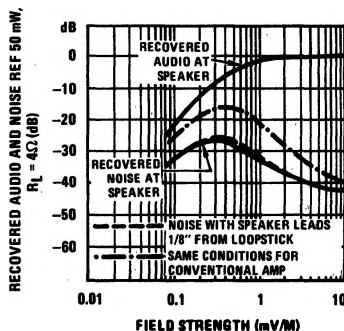

FIGURE 3. Improved AM Sensitivity over Conventional Design

TL/H/7920-9

Application Hints (Continued)

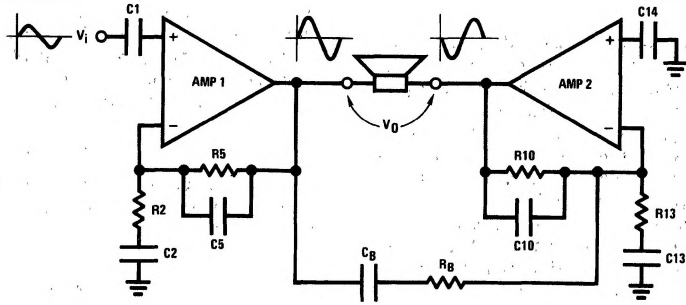

Figure 4. Bridge Amplifier Connection

TL/H/7920-10

Printed Circuit Layout

Printed Circuit Board Layout

Figure 5 and Figure 6 show printed circuit board layouts for the LM1896 and LM2896. The circuits are wired as stereo amplifiers. The signal source ground should return to the input ground shown on the boards. Returning the loads to power supply ground through a separate wire will keep the THD at its lowest value. The inputs should be terminated in

less than 50 kΩ to prevent an input-output oscillation. This oscillation is dependent on the gain and the proximity of the bridge elements R_B and C_B to the (+) input. If the bridge mode is not used, do not insert R_B, C_B into the PCB.

To wire the amplifier into the bridge configuration, short the capacitor on pin 7 (pin 1 of the LM1896) to ground. Connect together the nodes labeled BRIDGE and drive the capacitor connected to pin 5 (pin 14 of the LM1896).

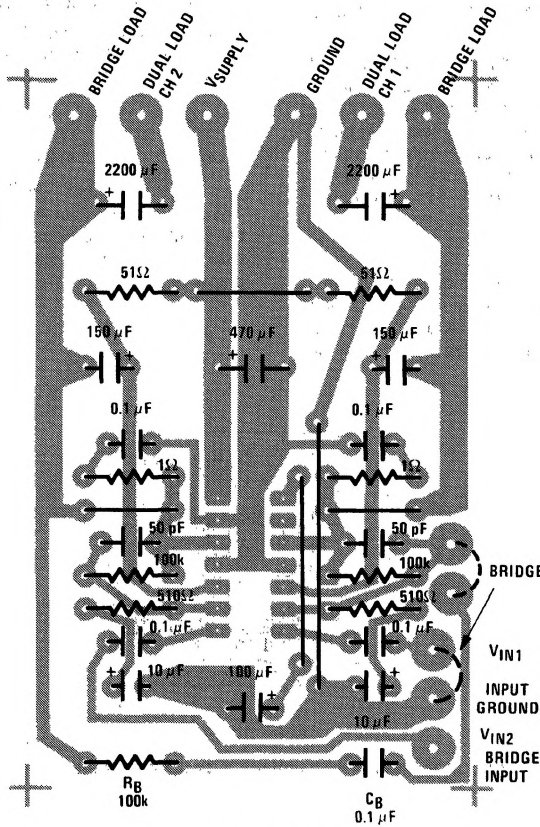

COMPONENT SIDE

FIGURE 5. Printed Circuit Board Layout for the LM1896

TL/H/7920-11

Printed Circuit Layout (Continued)

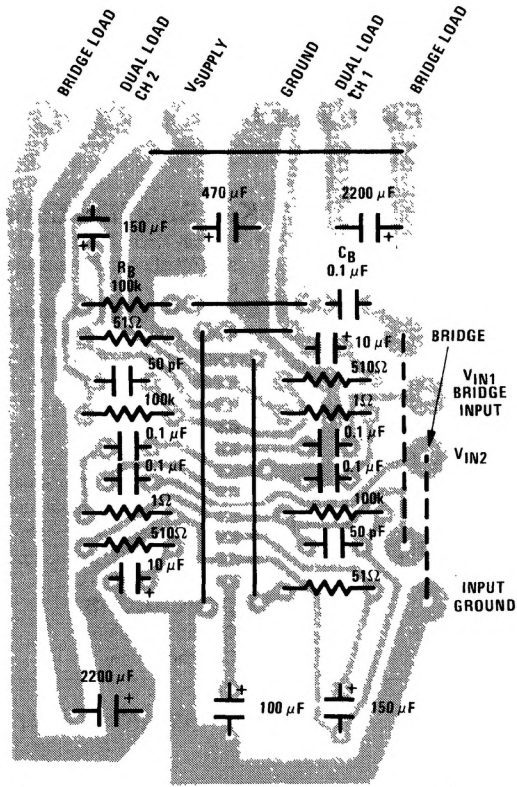

COMPONENT SIDE

FIGURE 6. Printed Circuit Board Layout for the LM2896

TL/H/7920-12