

## LM2889 TV Video Modulator

### General Description

The LM2889 is designed to interface audio and video signals to the antenna terminals of a TV receiver. It consists of a sound subcarrier oscillator and FM modulator, video clamp, and RF oscillators and modulators for two low-VHF channels.

The LM2889 allows video information from VTRs, video disk systems, games, test equipment, or similar sources to be displayed on black and white or color TV receivers.

### Features

- Pin for pin compatible with LM1889 RF section
- Low distortion FM sound modulator (less than 1% THD)
- Video clamp for AC-coupled video
- Low sound oscillator harmonic levels
- 10V to 16V supply operation
- DC channel switching
- Excellent oscillator stability
- Low intermodulation products

### Block and Connection Diagrams (Dual-In-Line Package)

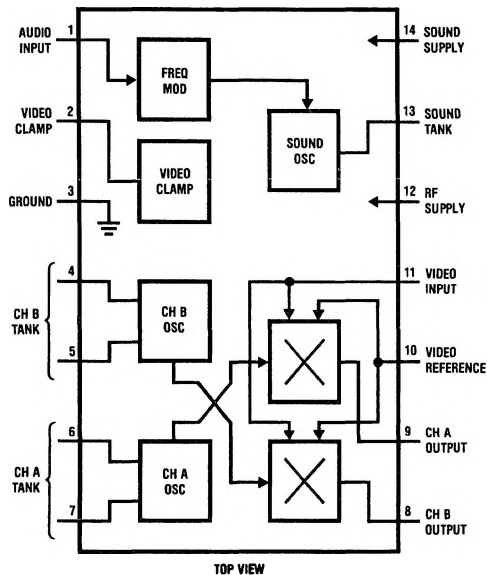

**Order Number LM2889N**  
**See NS Package Number N14A**

### DC Test Circuit

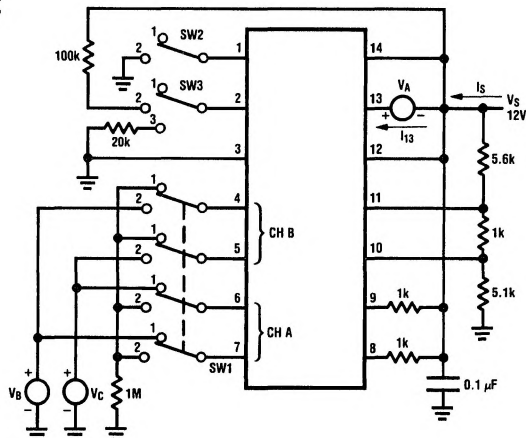

## Absolute Maximum Ratings

If Military/Aerospace specified devices are required, contact the National Semiconductor Sales Office/Distributors for availability and specifications.

Supply Voltage	18V <sub>DC</sub>
Power Dissipation Package (Note 1)	700 mW
Operating Temperature Range	0°C to +70°C

Storage Temperature Range	-55°C to +150°C
(V14-V13) Max	±5V <sub>DC</sub>
(V12-V8) Max	7V <sub>DC</sub>
(V12-V9) Max	7V <sub>DC</sub>
Lead Temperature (Soldering, 10 seconds)	260°C

## DC Electrical Characteristics

(DC test circuit, all switches normally pos. 1, V<sub>S</sub> = 12V, V<sub>A</sub> = 2V, V<sub>B</sub> = V<sub>C</sub> = 10V)

Parameter	Conditions	Min	Typ	Max	Units
Supply Current I <sub>S</sub>		10	16	25	mA
Sound Oscillator Current ΔI <sub>13</sub>	Change V <sub>A</sub> from -2V to +2V	0.2	0.35	0.6	mA
Sound Oscillator Zener Current I <sub>13</sub>			0.85		mA
Sound Modulator Audio Current ΔI <sub>13</sub>	Change SW2 from Pos. 1 to Pos. 2		0.9		mA
Video Clamp Voltage V2 Unloaded Loaded	SW3 Pos. 3	5.0	5.25 5.1	5.5	V <sub>DC</sub> V <sub>DC</sub>
Video Clamp Capacitor Discharge Current (V <sub>S</sub> -V2)/10 <sup>5</sup>	SW3 Pos. 2		20		μA
Ch. A Oscillator OFF Voltage, V6, V7	SW1 Pos. 2		2		mV <sub>DC</sub>
Ch. A Oscillator Current Level I <sub>7</sub>	V <sub>B</sub> = 10V, V <sub>C</sub> = 11V	2.5	3.5	5.0	mA
Ch. B Oscillator OFF Voltage V4, V5			2		mV <sub>DC</sub>
Ch. B Oscillator Current Level I <sub>4</sub>	SW1 Pos. 2, V <sub>B</sub> = 10V, V <sub>C</sub> = 11V	2.5	3.5	5.0	mA
Ch. A Modulator Conversion Ratio ΔV9/(V11-V10)	Measure ΔV9 by Changing from V <sub>B</sub> = 10V, V <sub>C</sub> = 11V, to V <sub>B</sub> = 11V, V <sub>C</sub> = 10V; Divide by V11-V10	0.3	0.50	0.75	V/V
Ch. B Modulator Conversion Ratio ΔV8/(V11-V10)	SW1 Pos. 2, Measure ΔV8 by Changing from V <sub>B</sub> = 10V, V <sub>C</sub> = 11V, to V <sub>B</sub> = 11V, V <sub>C</sub> = 10V; Divide by V11-V10	0.3	0.50	0.75	V/V

## AC Electrical Characteristics (AC test circuit, V<sub>S</sub> = 12V)

Parameter	Conditions	Min	Typ	Max	Units
Sound Carrier Oscillator Level (V13)			3.4		Vp-p
Sound Modulator Deviation	Δf/ΔV <sub>IN</sub> , SW1 Pos. 2, Change V <sub>IN</sub> from 1.4V to 1.0V, Measure Δf at Pin 13, Divide as Shown		250		Hz/mV
Ch. 3 RF Oscillator Level v6, v7	Ch. Sw. Pos. 3, f = 61.25 MHz, Use FET Probe		550		mVp-p
Ch. 4 RF Oscillator Level, v4, v5,	Ch. Sw. Pos. 4, f = 67.25 MHz, Use FET Probe		550		mVp-p
RF Modulator Conversion Gain v <sub>OUT</sub> /(V10-V11)	Ch. Sw. Pos. 3, f = 61.25 MHz. (Note 2)		10		mVrms/V

**Note 1:** For operation in ambient temperatures above 25°C, the device must be derated based on a 150°C maximum junction temperature and a thermal resistance of 80°C/W junction to ambient.

**Note 2:** Conversion gain shown is measured with 75Ω input RF meter which makes the AC RF output load 37.5Ω.

**Design Characteristics** (AC test circuit,  $V_S = 12V$ )

Parameter	Typ	Units
Sound Modulator Audio THD at $\pm 25$ kHz Deviation, $V_{IN}$ must be 1 kHz Source, Demodulate as Shown in Figure 1	0.8	%
Sound Modulator Input Impedance (Pin 1)	1.5	$k\Omega$
Sound Modulator Bandwidth	100	kHz
Oscillator Supply Dependence, Sound Carrier, RF	See Curves	
Oscillator Temperature Dependence (IC Only)		
Sound Carrier	-15	ppm/ $^{\circ}C$
RF	-50	ppm/ $^{\circ}C$
RF Oscillator Maximum Operating Frequency (Temperature Stability Degraded)	100	MHz
RF Modulator		
Carrier Suppression (Adjust Video Bias for Minimum RF Carrier at $v_{OUT}$ and Reference to $v_{OUT}$ with 3V Offset at Pins 10 and 11, See Applications Information, RF Modulation Section)	30	dB
3.58 MHz Differential Gain	5	%
Differential Phase	3	degrees
2.5V Vp-p Video, 87.5% Mod		
Output Harmonics below RF Carrier		
2nd, 3rd	-12	dB
4th and Above	-20	dB
Input Impedance, Pin 10, Pin 11	1 M $\Omega$ /2 pF	

**AC Test Circuit**

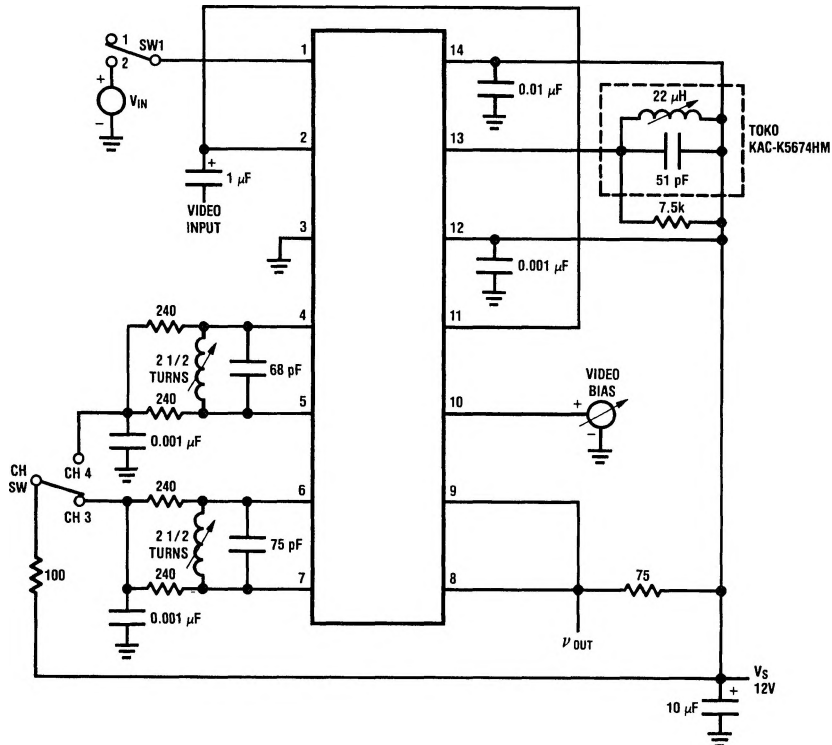

TL/H/5079-2

**Test Circuit**

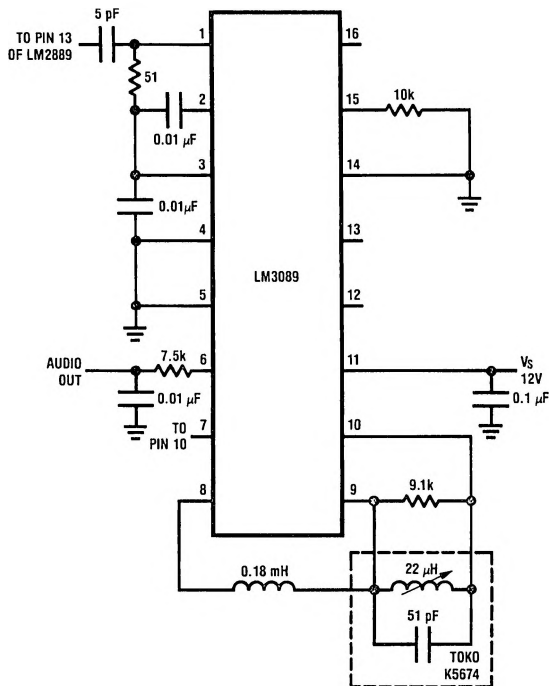

TL/H/5079-3

**FIGURE 1. 4.5 MHz Sound FM Demodulator**

**Typical Performance Characteristics** (Refer to AC test circuit unless noted)

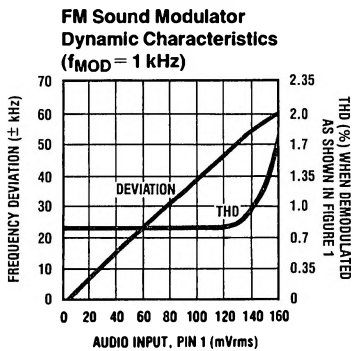
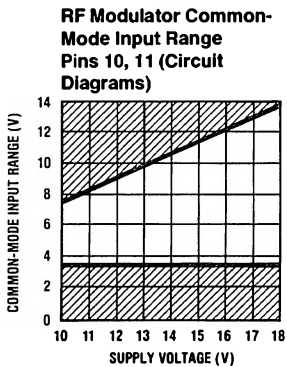
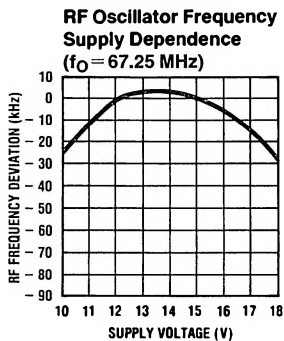
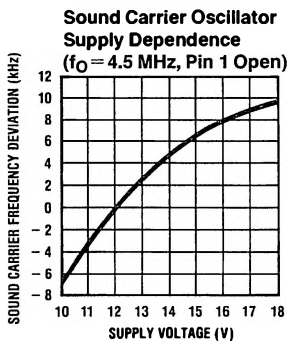

TL/H/5079-4

## Circuit Description (Refer to Circuit Diagrams)

The sound carrier oscillator is formed by differential amplifier Q3, Q4 operated with positive feedback from the pin 13 tank to the base of Q4. Frequency modulation is obtained by varying the 90 degree phase shifted current of Q9. Q14's emitter is a virtual ground, so the voltage at pin 1 determines the current R11, which ultimately modulates the collector current of Q9.

The video clamp is comprised of devices Q58-Q60. The clamp voltage is set by resistors R40, R41, R49, and R50. The  $\Delta V_{BE}/R42$  current sets the capacitor discharge current. Q59 and the above mentioned resistor string help maintain a temperature stable clamp voltage.

The channel B oscillator consists of devices Q24 and Q25 cross-coupled through level-shift zener diodes Q22 and Q23. A current regulator consisting of devices Q17-Q21 is used to achieve good RF stability over temperature and

supply. The channel B modulator consists of multiplier devices Q28-Q31, Q34 and Q35. The top quad is coupled to the channel B tank through isolating devices Q26 and Q27. A DC potential between pins 10 and 11 offsets the lower pair to produce an output RF carrier at pin 8. That carrier is then modulated by both the sound subcarrier at pin 10 and the composite video signal at pin 11. The channel A modulator shares pin 10 and 11 buffers, Q32 and Q33, with channel B and operates in an identical manner.

The current flowing through channel B oscillator diodes Q22, Q23 is turned around in Q36-Q38 to source current for the channel B RF modulator. In the same manner, the channel A oscillator Q54-Q57 uses turn-around Q49-Q51 to source the channel A modulator. One oscillator at a time may be activated by its current turn-around, and the other oscillator/modulator combination remains off.

## Circuit Diagrams

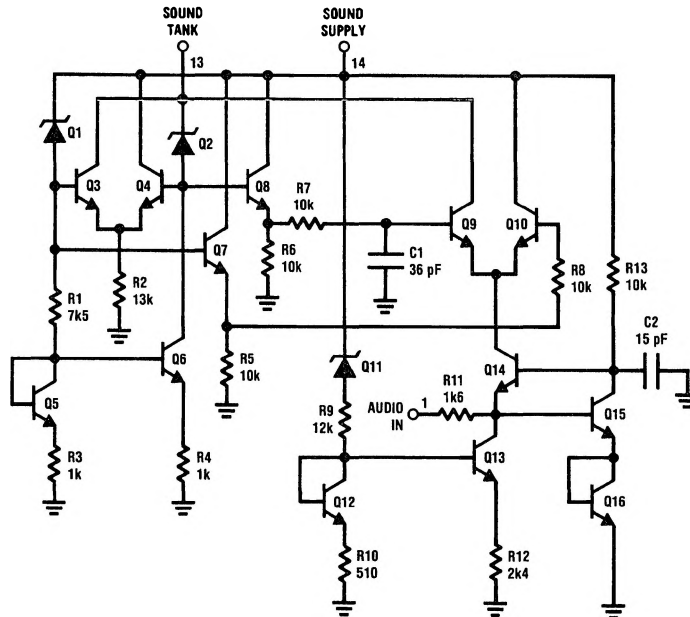

TL/H/5079-5

# Circuit Diagrams (Continued)

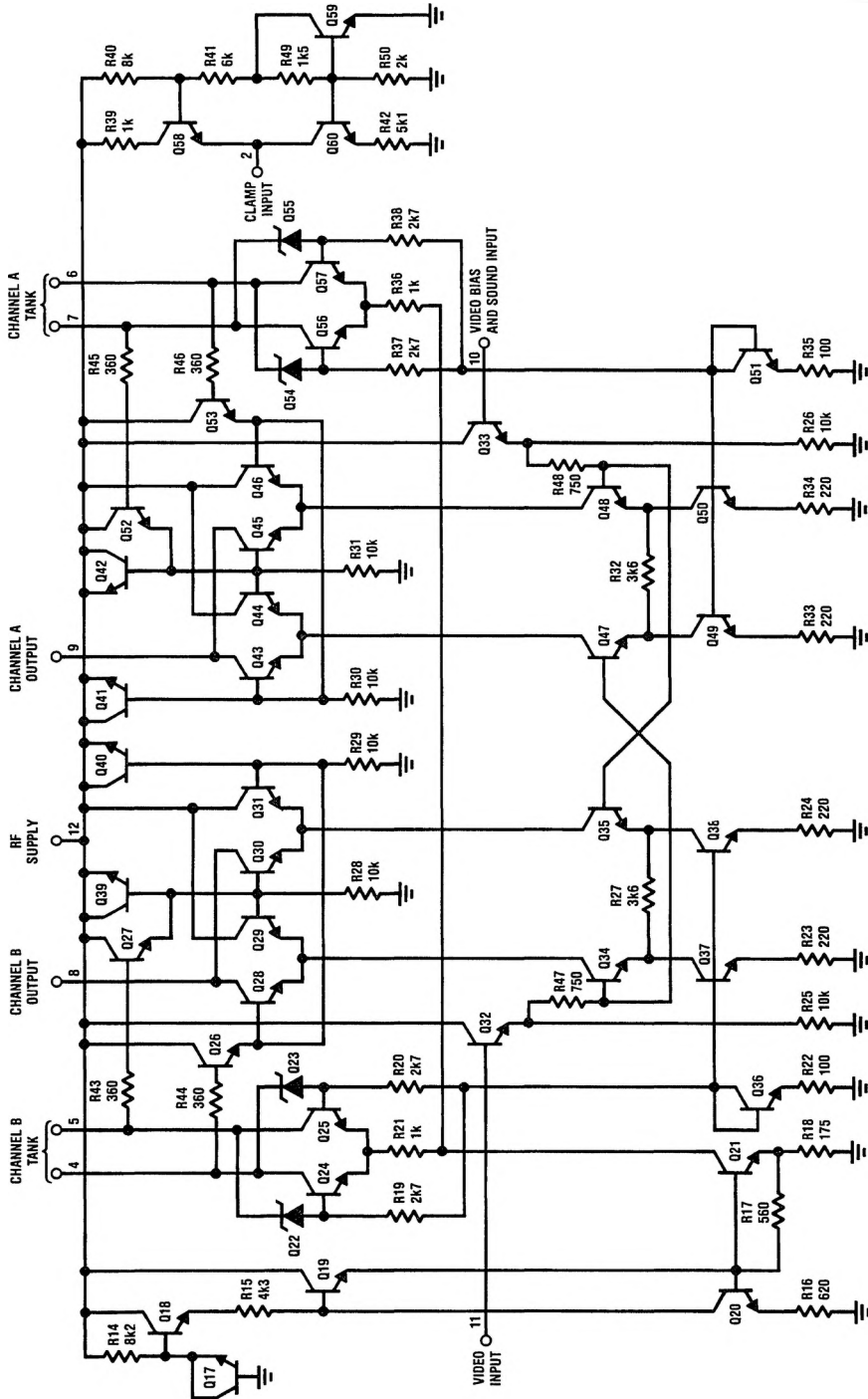

TL/H/5079-6

## Applications Information

### SOUND FM MODULATOR

Frequency deviation is determined by the Q of the tank circuit at pin 13 and the current entering the audio input, pin 1. This current is set by the input voltage  $V_{IN}$ , the device input impedance (1.5 k $\Omega$ ), and any impedance network connected externally. A signal of 60 mVrms at pin 1 will yield about  $\pm 25$  kHz deviation when configured as shown in *Figure 2*.

### VIDEO CLAMP

When video is not available at DC levels within the RF modulator common-mode range, or if the DC level of the video is not temperature stable, then it should be AC-coupled as shown in the typical applications circuit (*Figure 2*). The clamp holds the horizontal sync pulses at 5.2V for  $V_S = 12V$ . The clamp coupling capacitor is charged during every sync pulse and discharged when video information is present. The discharge current is approximately 20  $\mu A$ . This current and the amount of acceptable tilt over a line of video determines the value of the coupling capacitor C1. For most applications 1  $\mu F$  is sufficient.

### RF MODULATION

Two RF channels are available, with carrier frequencies up to 100 MHz being determined by L-C tank circuits at pins 4/ 5 and 6/7. The signal inputs (pins 10 and 11) are common to both modulators, but removing the power supply from an RF oscillator will also disable that modulator.

The offset between the two signal pins determines the level of the RF carrier output. To preserve the DC content of the video signal, amplitude modulation of the RF carrier is done in one direction only, with increasing video (toward peak white) decreasing the carrier level. This means the active composite video signal at pin 11 must be offset with respect to pin 10 and the sync pulse should produce the largest offset.

The largest video signal (peak white) should not be able to suppress the carrier completely, particularly if sound transmission is needed. This requires that pin 10 be biased above the largest expected video signal. Because peak white level is often difficult to define, a good rule to follow is to bias pin 10 at a level which is four times the sync amplitude above the sync tip level at pin 11. For example, the DC bias at pin 10 with 0.5V sync clamped to 5.2V on pin 11, should be  $5.2 + (4 \times 0.5) = 7.2V$ .

### Typical Application

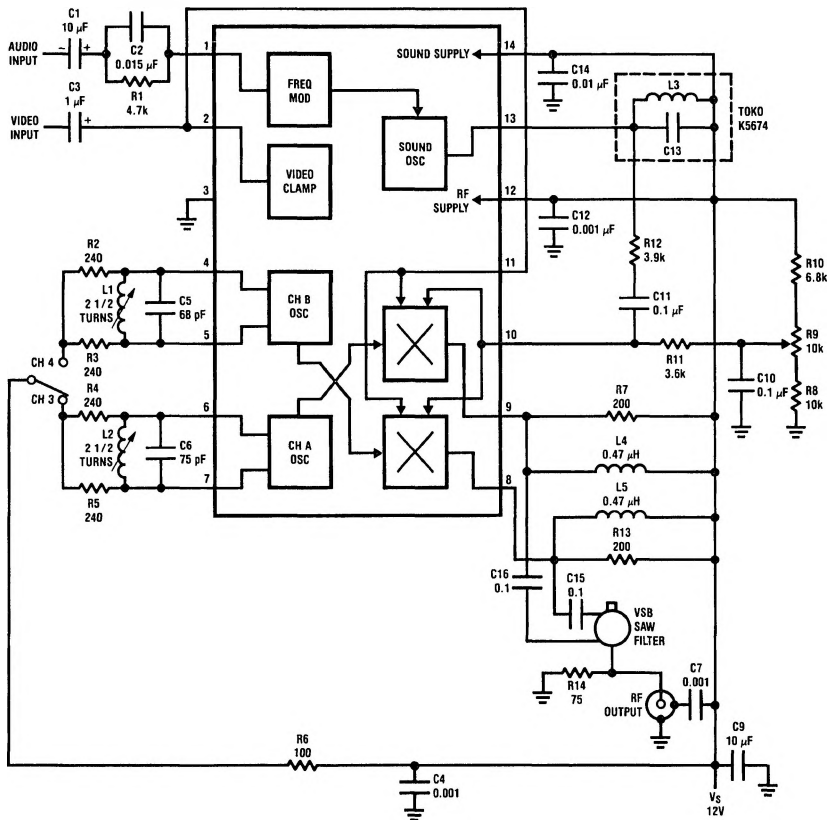
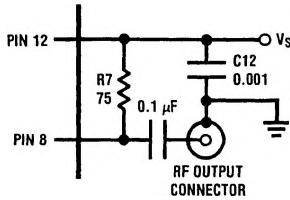

FIGURE 2. Two Channel Video Modulator with FM Sound

TL/H/5079-7

## Applications Information (Continued)

When the signal inputs are exactly balanced, ideally there is no RF carrier at the output. Circuit board layout is critical to this measurement. For optimum performance, the output and supply decoupling circuitry should be configured as shown in *Figure 3*.



TL/H/5079-8

RF decouple supply directly to output ground.

**FIGURE 3. Correct RF Supply Decoupling**

The video clamp level is derived from a resistive divider connected to supply ( $V_S$ ). To maintain good supply rejection, pin 10, which is biased externally, should also be referenced to supply (see *Figure 2*).

## Pin Description (Refer to *Figure 2*)

**Pin 1—Audio Input:** Pin 1 is the audio input to the sound FM generator. Frequency deviation is proportional to the signal at this pin. A pre-emphasis network comprised of R1, C2, and the device input impedance yields the following response with an 80 mVrms audio input.

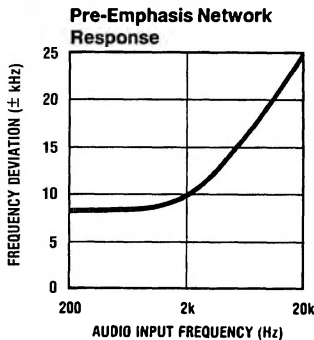

TL/H/5079-9

Increasing R1 lowers the boost frequency, and decreases deviation below the boost frequency. Increasing C2 only lowers the boost frequency. C1 is a coupling capacitor, and must be a low impedance compared to the sum of R1 and the device input impedance (1.5 k $\Omega$ ).

**Pin 2—Video Clamp:** The video clamp restores the DC component to AC-coupled video. The video is AC-coupled to the clamp via C3. Decreasing C3 will cause a larger tilt between vertical sync pulses in the clamped video waveform.

**Pin 3—Ground:** Although separate on the chip level, all ground terminate at pin 3.

**Pins 4/5—Channel 4 Oscillator:** Pins 4 and 5 are the collector outputs of the channel 4 oscillator. L1 and C5 set the oscillator frequency defined by  $f_0 = 0.159 / \sqrt{L1C5}$ . Increasing L1 will decrease the oscillator frequency while decreasing L1 will increase the oscillator frequency. Decreasing C5 will increase the oscillator frequency and lower the tank Q causing possible drift problems. R2 and R3 are the oscillator loads which determine the oscillator amplitude and the tank Q. Increasing these resistors increases the Q and the oscillator amplitude, possibly overdriving the RF modulator, which will increase output RF harmonics. Decreasing R2 and R3 reduces the tank Q and may cause increased drift. C4 is an RF decoupling capacitor. Increasing C4 may result in less effective decoupling at RF. Decreasing C4 may introduce RF to supply coupling.

**Pins 6/7—Channel 3 Oscillator:** Pins 6 and 7 are the channel 3 oscillator outputs. Every component at these pins has the same purpose and effect as those at pins 4 and 5.

**Pin 8—Channel 4 RF Output:** Pin 8 is the channel 4 RF output and R13 is the load resistor. The RF signal is AC coupled via C15 to the output filter which is a two channel VSB filter. L5 is parallel resonant with the filter input capacitance minimizing loss in the output network. R14 terminated the filter output.

**Pin 9—Channel 3 RF Output:** Pin 9 is the channel 3 RF output with all components performing the same functions as those in the pin 8 description.

**Pin 10—RF Modulator Sound Subcarrier Input:** Pin 10 is one of the RF modulator inputs and may be used for video or sound. It is used as a sound subcarrier input in *Figure 2*. R8, R9, and R10 set the DC bias on this pin which determines the modulation depth of the RF output (see Application Notes). R12 and C11 AC-couple the sound subcarrier from the sound modulator to the RF modulator. R12 and R11 form a resistive divider that determines the level of sound at pin 10; which in turn sets the picture carrier to sound subcarrier ratio. Increasing the ratio of R11/R12 will increase the sound subcarrier at the output. C10 forms an AC ground, preventing R8, R9, and R10 from having any effects on the circuit other than setting the DC potential at pin 10. R11 and R12 also effect the FM sound modulator (see pin 13 description).

