



## LM2878 Dual 5 Watt Power Audio Amplifier

### General Description

The LM2878 is a high voltage stereo power amplifier designed to deliver 5W/channel continuous into  $8\Omega$  loads. The amplifier is ideal for use with low regulation power supplies due to the absolute maximum rating of 35V and its superior power supply rejection. The LM2878 is designed to operate with a low number of external components, and still provide flexibility for use in stereo phonographs, tape recorders, and AM-FM stereo receivers. The flexibility of the LM2878 allows it to be used as a power operational amplifier, power comparator or servo amplifier. The LM2878 is internally compensated for all gains greater than 10, and comes in an 11-lead single-in-line package (SIP). The package has been redesigned, resulting in the slightly degraded thermal characteristics shown in the figure Device Dissipation vs Ambient Temperature.

### Features

- Wide operating range 6V–32V
- 5W/channel output
- 60 dB ripple rejection, output referred
- 70 dB channel separation, output referred
- Low crossover distortion
- AC short circuit protected
- Internal thermal shutdown

### Applications

- Stereo phonographs
- AM-FM radio receivers
- Power op amp, power comparator
- Servo amplifiers

### Typical Applications

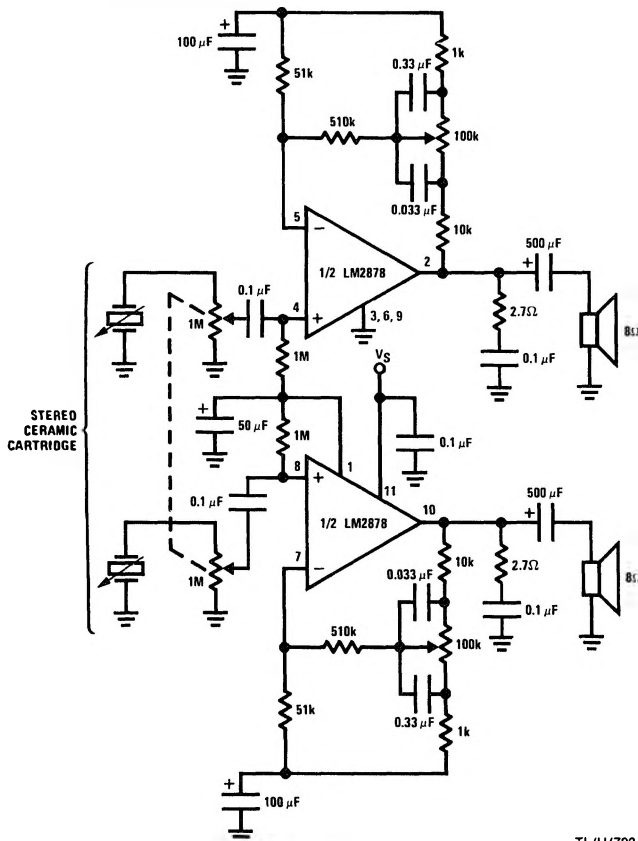

TL/H/7934-1

FIGURE 1. Stereo Phonograph Amplifier with Bass Tone Control

Frequency Response  
of Bass Tone Control

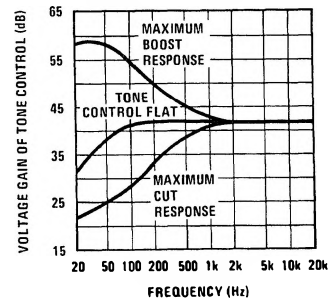

TL/H/7934-2

## Absolute Maximum Ratings

If Military/Aerospace specified devices are required, contact the National Semiconductor Sales Office/Distributors for availability and specifications.

Supply Voltage 35V  
Input Voltage (Note 1)  $\pm 0.7V$

Operating Temperature (Note 2)  $0^{\circ}C$  to  $+70^{\circ}C$   
Storage Temperature  $-65^{\circ}C$  to  $+150^{\circ}C$   
Junction Temperature  $+150^{\circ}C$   
Lead Temperature (Soldering, 10 sec.)  $+260^{\circ}C$

## Electrical Characteristics $V_S = 22V$ , $T_{TAB} = 25^{\circ}C$ , $R_L = 8\Omega$ , $A_V = 50$ (34 dB) unless otherwise specified.

Parameter	Conditions	Min	Typ	Max	Units
Total Supply Current	$P_O = 0W$		10	50	mA
Operating Supply Voltage		6		32	V
Output Power/Channel	$f = 1\text{ kHz}$ , THD = 10%, $T_{TAB} = 25^{\circ}C$	5	5.5		W
Distortion	$f = 1\text{ kHz}$ , $R_L = 8\Omega$ $P_O = 50\text{ mW}$		0.20		%
	$P_O = 0.5W$		0.15		%
	$P_O = 2W$		0.14		%
Output Swing	$R_L = 8\Omega$		$V_S - 6V$		Vp-p
Channel Separation	$C_{BYPASS} = 50\ \mu F$ , $C_{IN} = 0.1\ \mu F$ $f = 1\text{ kHz}$ , Output Referred $V_O = 4\text{ Vrms}$	-50	-70		dB
PSRR Power Supply Rejection Ratio	$C_{BYPASS} = 50\ \mu F$ , $C_{IN} = 0.1\ \mu F$ $f = 120\text{ Hz}$ , Output Referred $V_{ripple} = 1\text{ Vrms}$	-50	-60		dB
PSRR Negative Supply	Measured at DC, Input Referred		-60		dB
Common-Mode Range	Split Supplies $\pm 15V$ , Pin 1 Tied to Pin 11		$\pm 13.5$		V
Input Offset Voltage			10		mV
Noise	Equivalent Input Noise $R_S = 0$ , $C_{IN} = 0.1\ \mu F$ $BW = 20 - 20\text{ kHz}$		2.5		$\mu V$
	CCIR*ARM		3.0		$\mu V$
	Output Noise Wideband $R_S = 0$ , $C_{IN} = 0.1\ \mu F$ , $A_V = 200$		0.8		mV
Open Loop Gain	$R_S = 51\Omega$ , $f = 1\text{ kHz}$ , $R_L = 8\Omega$		70		dB
Input Bias Current			100		nA
Input Impedance	Open Loop		4		M $\Omega$
DC Output Voltage	$V_S = 22V$	10	11	12	V
Slew Rate			2		V/ $\mu S$
Power Bandwidth	3 dB Bandwidth at 2.5W		65		kHz
Current Limit			1.5		A

Note 1:  $\pm 0.7V$  applies to audio applications; for extended range, see Application Hints.

Note 2: For operation at ambient temperature greater than  $25^{\circ}C$ , the LM2878 must be derated based on a maximum  $150^{\circ}C$  junction temperature using a thermal resistance which depends upon device mounting techniques.

# Typical Performance Characteristics

**Device Dissipation vs Ambient Temperature**

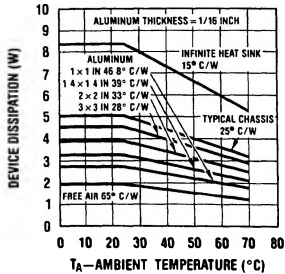

**Power Supply Rejection Ratio (Referred to the Output) vs Frequency**

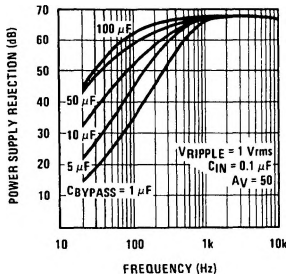

**Power Supply Rejection Ratio (Referred to the Output) vs Frequency**

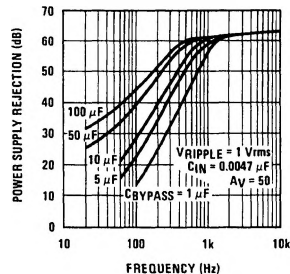

**Power Supply Rejection Ratio (Referred to the Voltage) vs Supply Voltage**

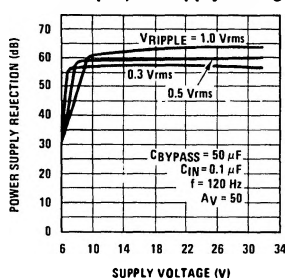

**Channel Separation (Referred to the Output) vs Frequency**

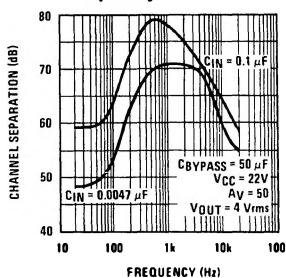

**Total Harmonic Distortion vs Frequency**

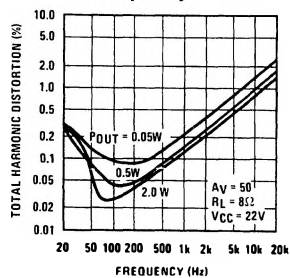

**Total Harmonic Distortion vs Frequency**

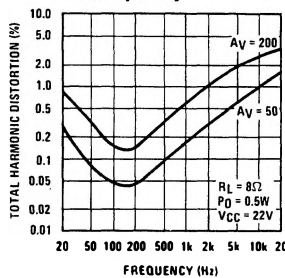

**Total Harmonic Distortion vs Power Out**

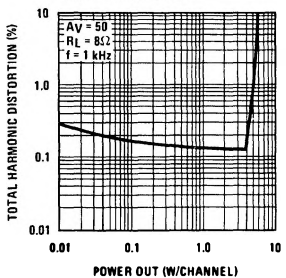

**Open Loop Gain vs Frequency**

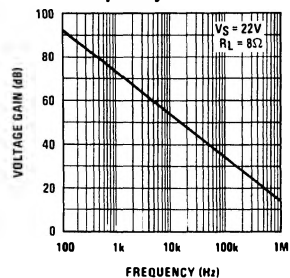

**Power Output/Channel vs Supply Voltage**

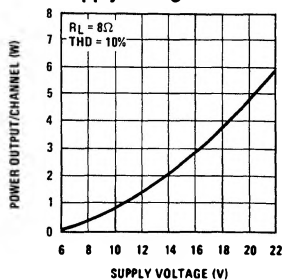

**Power Dissipation vs Power Out**

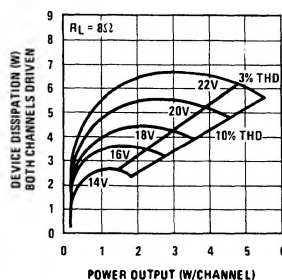

# Equivalent Schematic Diagram

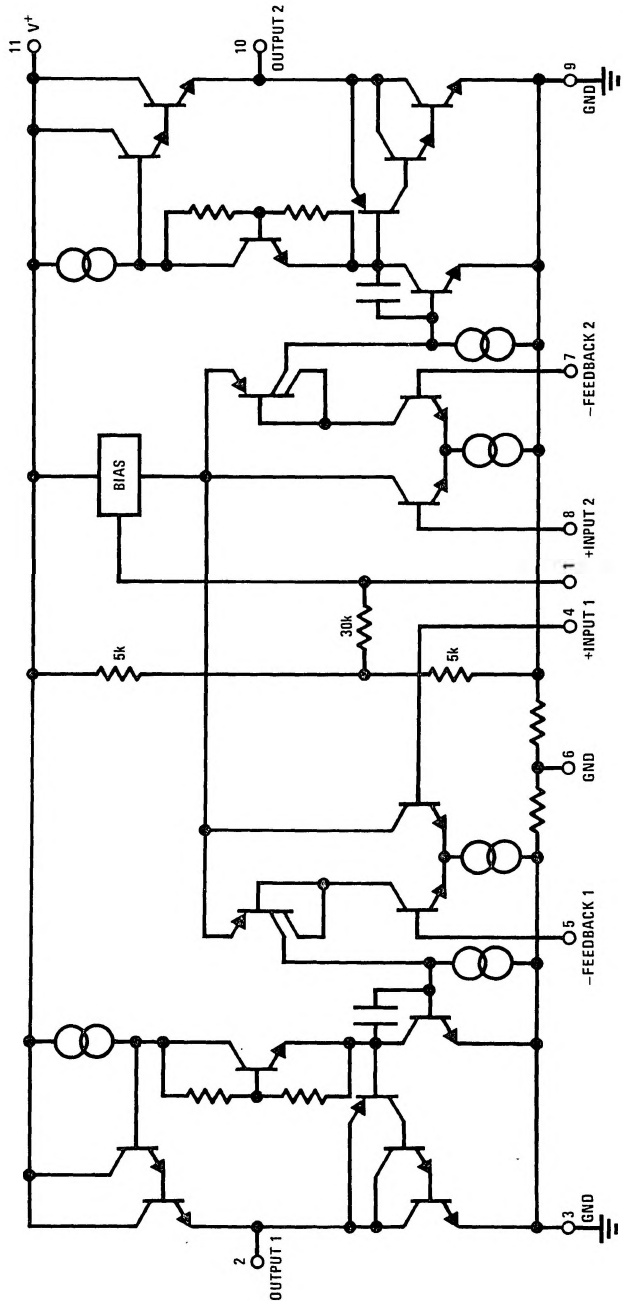

TL/H/7894-4

LM2878

## Connection Diagram

### Single-In-Line Package

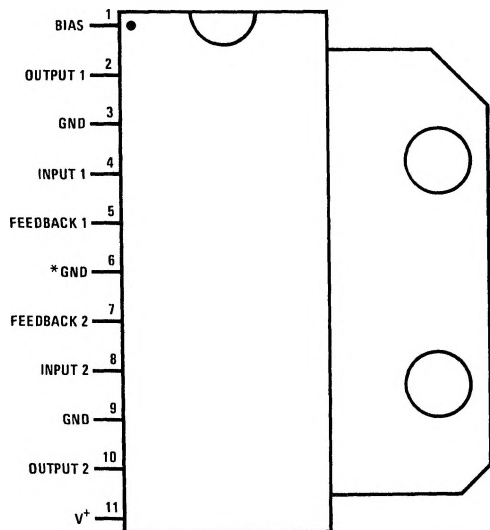

### Top View

TL/H/7934-5

\*Pin 6 can be connected to pin 3 or pin 9, if not, pin 6 must be left with NO connection.

**Order Number LM2878P**  
**See NS Package Number P11A**

## Application Hints

The LM2878 is an improved LM378 in typical audio applications. In the LM2878, the internal voltage regulator for the input stage is generated from the voltage on pin 1. Normally, the input common-mode range is within  $\pm 0.7V$  of this pin 1 voltage. Nevertheless the common-mode range can be increased by externally forcing the voltage on pin 1. One way to do this is to short pin 1 to the positive supply, pin 11.

The only special care required with the LM2878 is to limit the maximum input differential voltage to  $\pm 7V$ . If this differential voltage is exceeded, the input characteristics may change.

Figure 2 shows a power op amp application with  $A_V = 1$ . The 100k and 10k resistors set a noise gain of 10 and are dictated by amplifier stability. The 10k resistor is bootstrapped by the feedback so the input resistance is dominated by the 1 M $\Omega$  resistor.

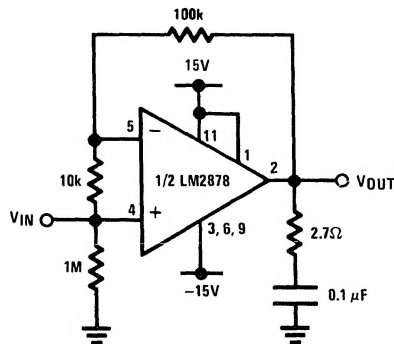

TL/H/7934-6

**FIGURE 2. Operational Power Amplifier,  $A_V = 1$**

## External Components (Figure 3)

1. R2, R5, R7, R10 Sets voltage gain  $A_V = 1 + R2/R5$  for one channel and  $A_V = 1 + R10/R7$  for the other channel.
2. R4, R8 Resistors set input impedance and supply bias current for the positive input.
3. R<sub>O</sub> Works with C<sub>O</sub> to stabilize output stage.
4. C1 Improves power supply rejection (see Typical Performance Characteristics).
5. C11 Stabilizes amplifier, may need to be larger depending on power supply filtering.

6. C4, C8

Input coupling capacitor. Pins 4 and 8 are at a DC potential of  $V_S/2$ . Low frequency pole set by:

$$f_L = \frac{1}{2\pi R4C4}$$

7. C5, C7

Feedback capacitors. Ensure unity gain at DC. Also low frequency pole at:

$$f_L = \frac{1}{2\pi R5C5}$$

8. C<sub>O</sub>

Works with R<sub>O</sub> to stabilize output stage.

9. C2, C10

Output coupling capacitor. Low frequency pole given by:

$$f_L = \frac{1}{R\pi RLC2}$$

## Typical Applications (Continued)

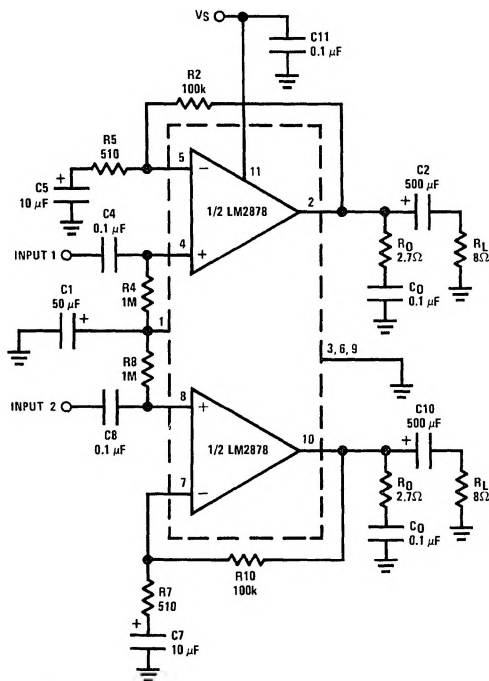

FIGURE 3. Stereo Amplifier with  $A_V = 200$

TL/H/7934-7

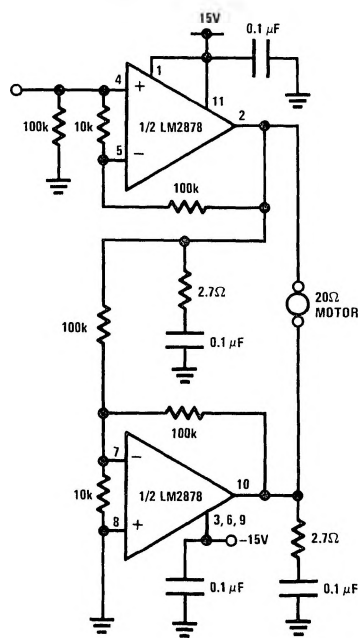
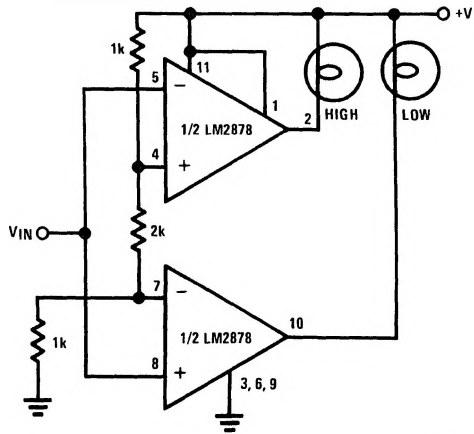

FIGURE 4. LM2878 Servo Amplifier in Bridge Configuration

TL/H/7934-8

## Typical Applications (Continued)



Truth Table

$V_{IN}$	High	Low
$< \frac{1}{4}V^+$	Off	On
$\frac{1}{4}V^+$ to $\frac{3}{4}V^+$	Off	Off
$> \frac{3}{4}V^+$	On	Off

TL/H/7934-9

FIGURE 5. Window Comparator Driving High, Low Lamps