

LM2877 Dual 4W Audio Power Amplifier

General Description

The LM2877 is a monolithic dual power amplifier designed to deliver 4W/channel continuous into 8Ω loads. The LM2877 is designed to operate with a low number of external components, and still provide flexibility for use in stereo phonographs, tape recorders and AM-FM stereo receivers, etc. Each power amplifier is biased from a common internal regulator to provide high power supply rejection and output Q point centering. The LM2877 is internally compensated for all gains greater than 10, and comes in an 11-lead single-in-line package.

Features

- 4W/channel
- -68 dB ripple rejection, output referred
- -70 dB channel separation, output referred

- Wide supply range, 6-24V
- Very low cross-over distortion
- Low audio band noise
- AC short circuit protected
- Internal thermal shutdown

Applications

- Multi-channel audio systems
- Stereo phonographs
- Tape recorders and players
- AM-FM radio receivers
- Servo amplifiers
- Intercom systems
- Automotive products

Connection Diagram

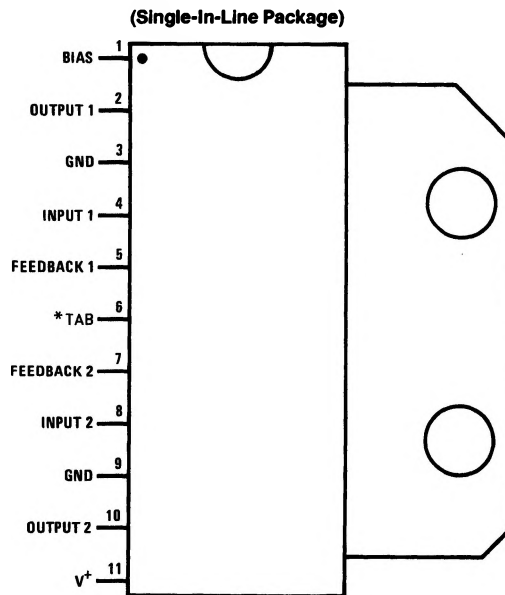

Top View

Order Number LM2877P
See NS Package Number P11A

TL/H/7933-1

*Pin 6 must be connected to GND.

Absolute Maximum Ratings

If Military/Aerospace specified devices are required, please contact the National Semiconductor Sales Office/Distributors for availability and specifications.

Supply Voltage	26V
Input Voltage	$\pm 0.7V$
Operating Temperature	0°C to +70°C

Storage Temperature	-65°C to +150°C
Junction Temperature	150°C
Lead Temperature (Soldering, 10 sec.)	260°C
Thermal Resistance	
θ_{JC}	10°C/W
θ_{JA}	55°C/W

Electrical Characteristics $V_S = 20V, T_{TAB} = 25^\circ C, R_L = 8\Omega, A_V = 50$ (34 dB) unless otherwise specified.

Parameter	Conditions	Min	Typ	Max	Units
Total Supply Current	$P_O = 0W$		25	50	mA
Operating Supply Voltage		6		24	V
Output Power/Channel	$f = 1\text{ kHz}, \text{THD} = 10\%, T_{TAB} = 25^\circ C$ $V_S = 20V$ $V_S = 18V$ $V_S = 12V, R_L = 4\Omega$ $V_S = 12V, R_L = 8\Omega$	4.0 1.5	4.5 3.6 1.9 1.0		W W W W
Distortion, THD	$f = 1\text{ kHz}, V_S = 20V$ $P_O = 50\text{ mW/Channel}$ $P_O = 1W/Channel$ $P_O = 2W/Channel$ $f = 1\text{ kHz}, V_S = 12V, R_L = 4\Omega$ $P_O = 50\text{ mW/Channel}$ $P_O = 500\text{ mW/Channel}$ $P_O = 1W/Channel$		0.1 0.07 0.07 0.25 0.20 0.15	1	% % % % % %
Output Swing	$R_L = 8\Omega$		$V_S - 4$		V_{P-P}
Channel Separation	$C_F = 50\ \mu F, C_{IN} = 0.1\ \mu F, f = 1\text{ kHz}$, Output Referred $V_S = 20V, V_O = 4\text{ Vrms}$ $V_S = 7V, V_O = 0.5\text{ Vrms}$	-50	-70 -60		dB dB
PSRR Power Supply	$C_F = 50\ \mu F, C_{IN} = 0.1\ \mu F, f = 120\text{ Hz}$				
Rejection Ratio	Output Referred $V_S = 20V, V_{RIPPLE} = 1\text{ Vrms}$ $V_S = 7V, V_{RIPPLE} = 0.5\text{ Vrms}$	-50	-68 -40		dB dB
Noise	Equivalent Input Noise $R_S = 0, C_{IN} = 0.1\ \mu F, BW = 20\text{ Hz}-20\text{ kHz}$ Output Noise Wideband $R_S = 0, C_{IN} = 0.1\ \mu F, A_V = 200$		2.5 0.80		μV mV
Open Loop Gain	$R_S = 0, f = 1\text{ kHz}, R_L = 8\Omega$		70		dB
Input Offset Voltage			15		mV
Input Bias Current			50		nA
Input Impedance	Open Loop		4		M Ω
DC Output Level	$V_S = 20V$	9	10	11	V
Slew Rate			2.0		V/ μs
Power Bandwidth			65		kHz
Current Limit			1.0		A

Note 1: For operation at ambient temperature greater than 25°C, the LM2877 must be derated based on a maximum 150°C junction temperature using a thermal resistance which depends upon device mounting techniques.

Equivalent Schematic Diagram

TL/H/7983-2

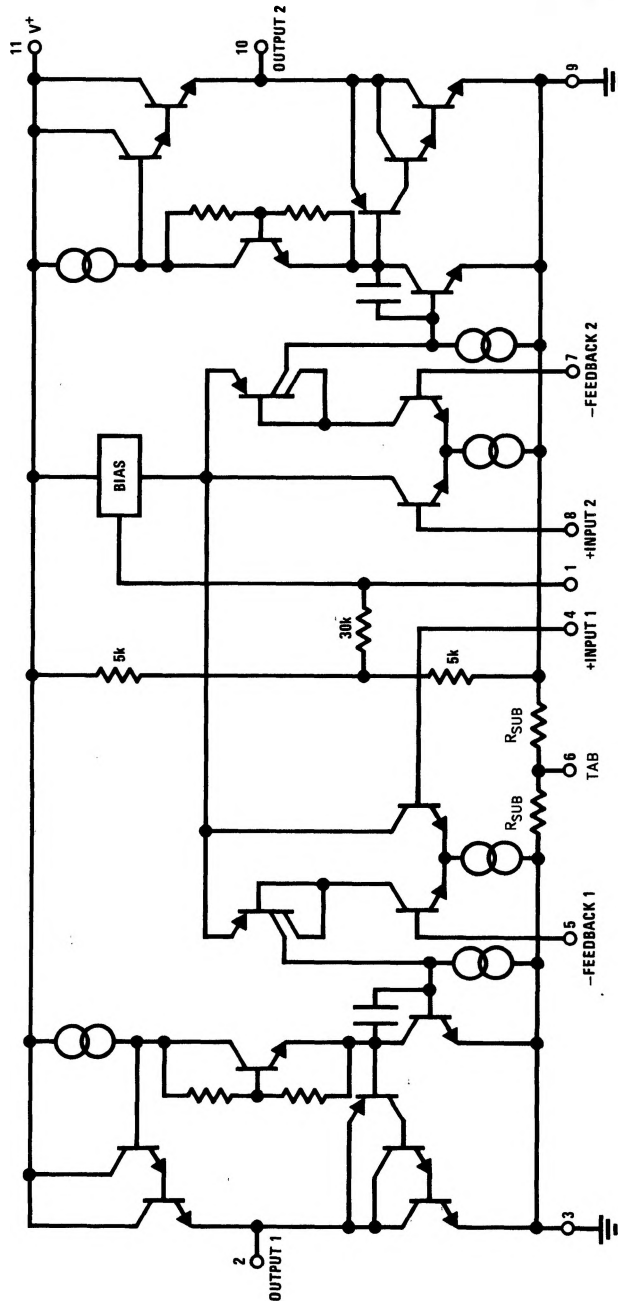

Typical Performance Characteristics

Device Dissipation vs Ambient Temperature

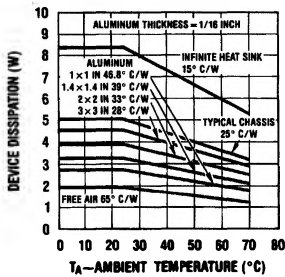

Power Supply Rejection Ratio (Referred to the Output) vs Frequency

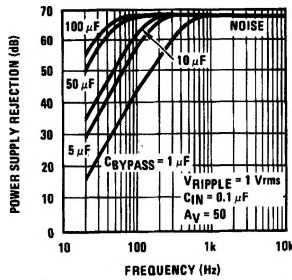

Power Supply Rejection Ratio (Referred to the Output) vs Frequency

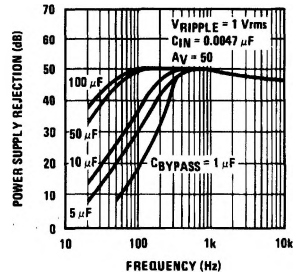

Power Supply Rejection Ratio (Referred to the Output) vs Supply Voltage

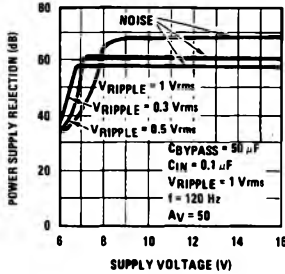

Channel Separation (Referred to the Output) vs Frequency

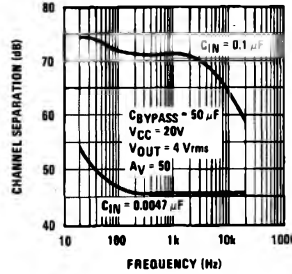

Channel Separation (Referred to the Output) vs Frequency

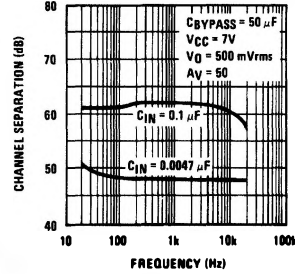

Average Supply Current vs Power Output

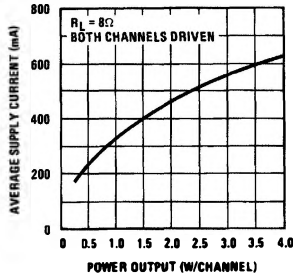

Total Harmonic Distortion vs Frequency

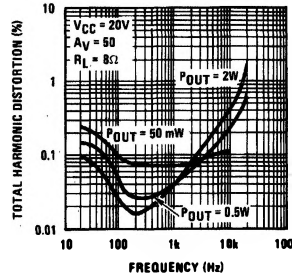

Total Harmonic Distortion vs Frequency

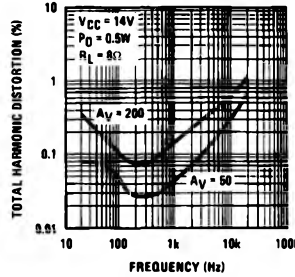

Power Dissipation vs Power Output

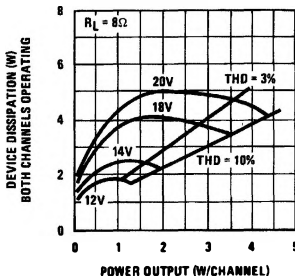

Open Loop Gain vs Frequency

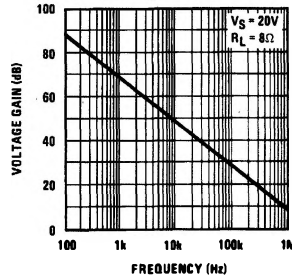

Output Swing vs Supply Voltage

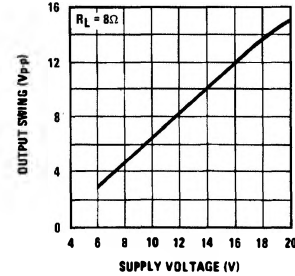

Typical Applications

Stereo Phonograph Amplifier with Bass Tone Control

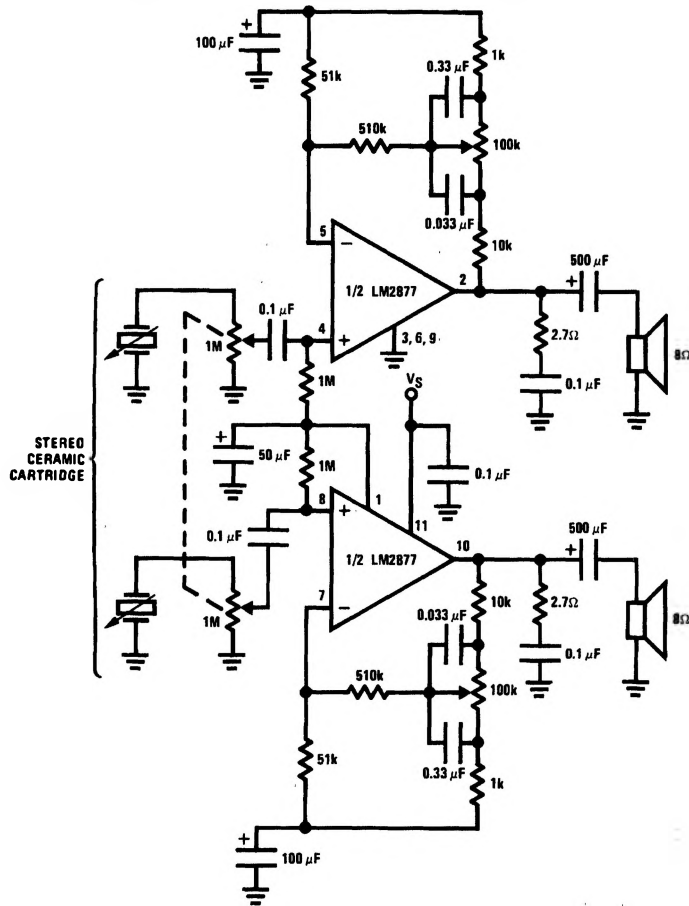

TL/H/7933-4

Frequency Response of Bass Tone Control

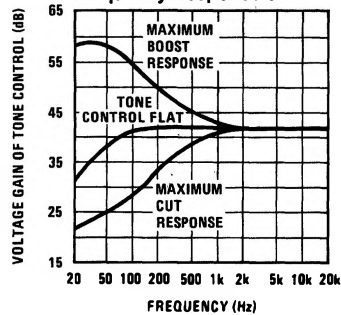

TL/H/7933-5

Typical Applications (Continued)

Stereo Amplifier with $A_v = 200$

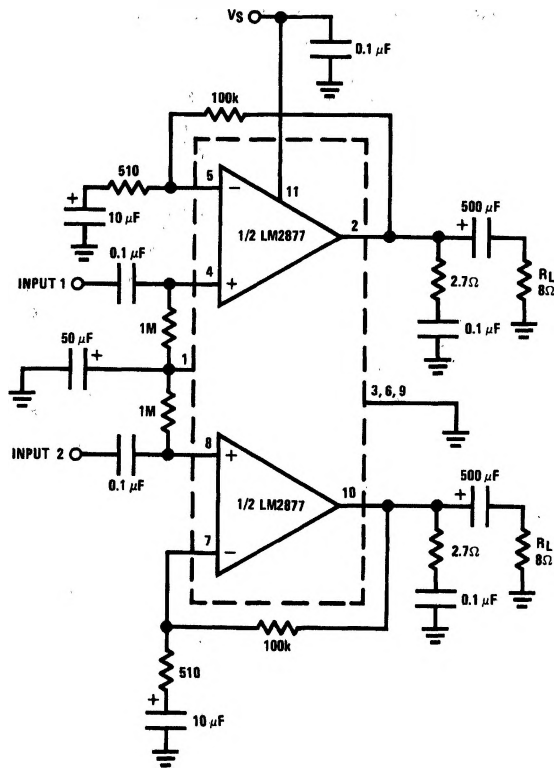

TL/H/7933-6

Non-Inverting Amplifier Using Split Supply

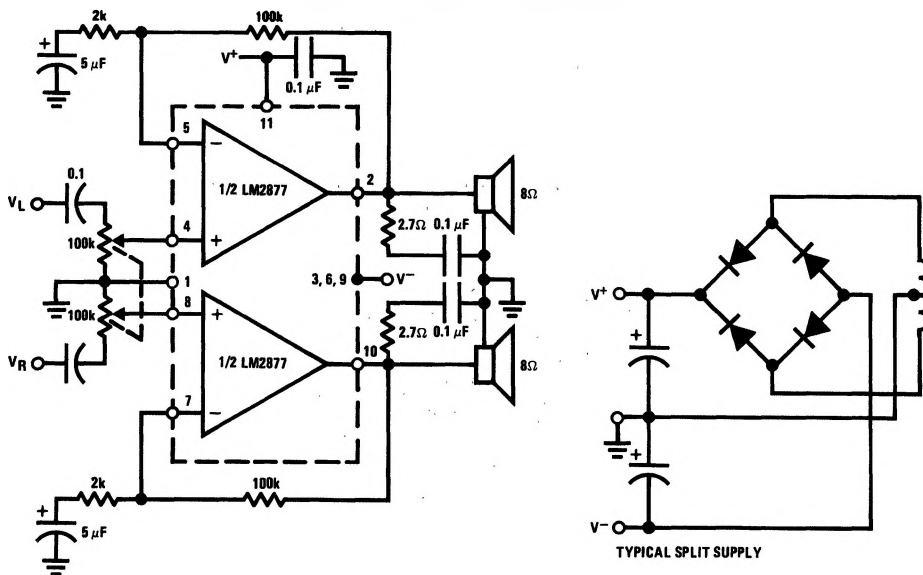

TL/H/7933-7

Typical Applications (Continued)

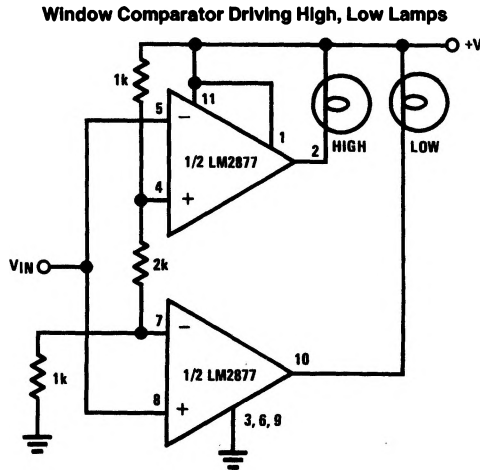

TL/H/7933-8

Truth Table

V_{IN}	High	Low
$< \frac{1}{4} V^+$	Off	On
$\frac{1}{4} V^+$ to $\frac{3}{4} V^+$	Off	Off
$> \frac{3}{4} V^+$	On	Off

Application Hints

The LM2877 is an improved LM377 in typical audio applications. In the LM2877, the internal voltage regulator for the input stage is generated from the voltage on pin 1. Normally, the input common-mode range is within $\pm 0.7V$ of this pin 1 voltage. Nevertheless, the common-mode range can be increased by externally forcing the voltage on pin 1. One way to do this is to short pin 1 to the positive supply, pin 11.

The only special care required with the LM2877 is to limit the maximum input differential voltage to $\pm 7V$. If this differential voltage is exceeded, the input characteristics may change.

Figure 1 shows a power op amp application with $A_V = 1$. The 100k and 10k resistors set a noise gain of 10 and are dictated by amplifier stability. The 10k resistor is bootstrapped by the feedback so the input resistance is dominated by the 1 M Ω resistor.

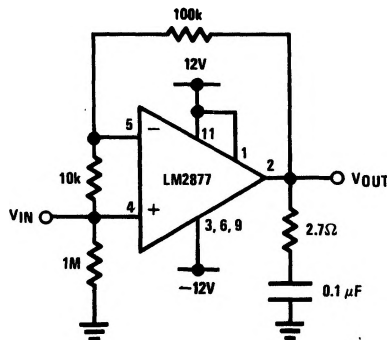

FIGURE 1

TL/H/7933-9