

LM2758 Switched Capacitor Flash LED Driver in DSBGA

Check for Samples: [LM2758](#)

FEATURES

- Up to 700 mA Output Current
- Ultra-Small Solution Size
 - No Inductor, Only 4 Capacitors and a Resistor Required
 - 1.514 mm x 1.996 mm x 0.6 mm Thin DSBGA package
- 90% Peak Efficiency
- Indicator, Torch and Flash Modes
- Time-Out Circuitry Limits Flash Duration to 814 msec. (typ.)

- Adaptive 1x and 1.5x Gains for Maximum Efficiency
- True Shutdown
- Internal Soft-Start Eliminates Inrush Current

APPLICATIONS

- Camera Flash in Mobile Phones
- Flash for Digital Cameras

DESCRIPTION

LM2758 is an integrated low-noise, high-current switched capacitor DC/DC converter with a regulated current sink. The device is capable of driving loads up to 700 mA from a single-cell Li-Ion battery. Maximum efficiency is achieved over the input voltage range by actively selecting the proper gain based on the LED forward voltage and current requirements.

One external low-power resistor sets the desired current for Indicator, Torch and Flash modes. To protect the devices and the flash LED, internal Time-out circuitry turns off the LM2758 in case of a faulty prolonged Flash mode. Internal soft-start circuitry limits the amount of inrush current during start-up.

LM2758 is offered in a tiny 12-bump thin DSBGA package.

Typical Application Circuit

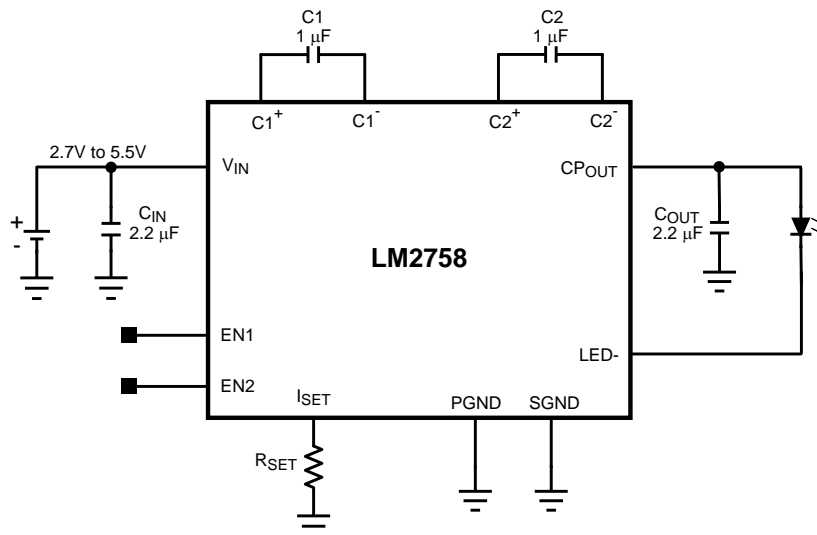

Please be aware that an important notice concerning availability, standard warranty, and use in critical applications of Texas Instruments semiconductor products and disclaimers thereto appears at the end of this data sheet.

All trademarks are the property of their respective owners.

Connection Diagram

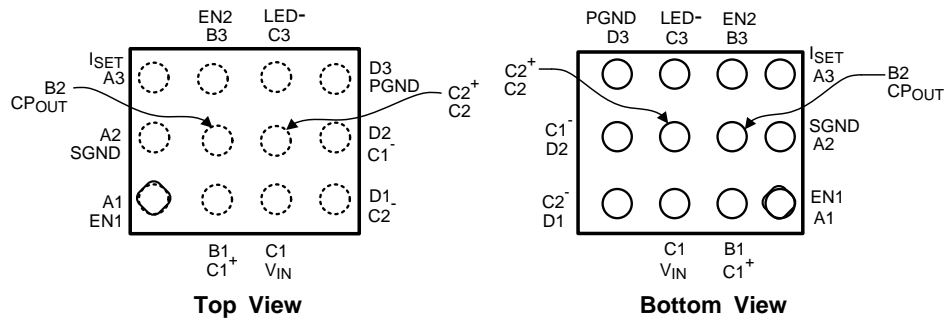

Figure 1. 12-Bump Thin DSBGA
1.514mm x 1.996mm x 0.6mm
Package Number YZR0012

PIN DESCRIPTIONS

Pin	Name	Description
C1	V _{IN}	Supply voltage connection.
B2	CP _{OUT}	Charge pump regulated output. A 2.2 μ F ceramic capacitor is required from CP _{OUT} to GND. Connect flash LED anode to this pin.
B1	C1+	Flying capacitor pins. A 1 μ F ceramic capacitor should be connected from C1+ to C1- and from C2+ to C2-.
D2	C1-	
C2	C2+	
D1	C2-	
A2	SGND	Analog and control ground for charge pump. This pin should be connected directly to a low impedance ground plane.
C3	LED-	Regulated current source output. Connect flash LED cathode to this pin.
A1	EN1	The EN1 and EN2 pins are used to select the modes (Torch, Indicator, Flash), as well as to put the part into Shutdown mode.
B3	EN2	
A3	I _{SET}	LED current programming resistor pin. A resistor connected between this pin and GND are used to set Torch, Flash and Indicator currents.
D3	PGND	Power ground for the charge pump and the current source. This pin should be connected directly to a low impedance ground plane.



These devices have limited built-in ESD protection. The leads should be shorted together or the device placed in conductive foam during storage or handling to prevent electrostatic damage to the MOS gates.

Absolute Maximum Ratings ⁽¹⁾⁽²⁾⁽³⁾

V_{IN} , CP_{OUT} pins: Voltage to GND	-0.3V to 6.0V
EN1, EN2 pins: Voltage to GND	-0.3V to ($V_{IN} + 0.3V$) w/ 6.0V max
Continuous Power Dissipation ⁽⁴⁾	Internally Limited
Junction Temperature (T_{J-MAX})	150°C
Storage Temperature Range	-65°C to 150°C
Maximum Lead Temp. (Soldering)	⁽⁵⁾
ESD Ratings ⁽⁶⁾	
Human Body Model	2kV
Machine Model	200V

- (1) If Military/Aerospace specified devices are required, please contact the Texas Instruments Sales Office/ Distributors for availability and specifications.
- (2) Absolute Maximum Ratings indicate limits beyond which damage to the component may occur. Operating Ratings are conditions under which operation of the device is guaranteed. Operating Ratings do not imply guaranteed performance limits. For guaranteed performance limits and associated test conditions, see the Electrical Characteristics tables.
- (3) All voltages are with respect to the potential to the GND pin.
- (4) Internal thermal shutdown circuitry protects the device from permanent damage. Thermal shutdown engages at $T_J=150^\circ\text{C}$ (typ.) and disengages at $T_J = 140^\circ\text{C}$ (typ.).
- (5) For detailed soldering specifications and information, please refer to Texas Instruments Application Note AN-1112.
- (6) The Human body model is a 100 pF capacitor discharged through a 1.5 k Ω resistor into each pin. The machine model is a 200pF capacitor discharged directly into each pin. MIL-STD-883 3015.7

Operating Ratings ⁽¹⁾⁽²⁾

Input Voltage Range	2.7V to 5.5V
Junction Temperature Range (T_J)	-40°C to +125°C
Ambient Temperature Range (T_A) ⁽³⁾	-40°C to +85 °C

- (1) Absolute Maximum Ratings indicate limits beyond which damage to the component may occur. Operating Ratings are conditions under which operation of the device is guaranteed. Operating Ratings do not imply guaranteed performance limits. For guaranteed performance limits and associated test conditions, see the Electrical Characteristics tables.
- (2) All voltages are with respect to the potential to the GND pin.
- (3) In applications where high power dissipation and/or poor package thermal resistance is present, the maximum ambient temperature may have to be derated. Maximum ambient temperature (T_{A-MAX}) is dependent on the maximum operation junction temperature ($T_{J-MAX-OP} = 125^\circ\text{C}$), the maximum power dissipation of the device in the application (P_{D-MAX}), and the junction-to ambient thermal resistance of the part/package in the application (θ_{JA}), as given by the following equation: $T_{A-MAX} = T_{J-MAX-OP} - (\theta_{JA} \times P_{D-MAX})$.

Thermal Information

Junction-to-Ambient Thermal Resistance	56°C/W
Resistance (θ_{JA}), DSBGA package ⁽¹⁾	

- (1) Junction-to-ambient thermal resistance (θ_{JA}) is taken from a thermal modeling result, performed under the conditions and guidelines set forth in the JEDEC standard JESD51-7. The test board is a 4-layer FR-4 board measuring 102 mm x 76 mm x 1.6 mm with a 2x1 array of thermal vias. The ground plane on the board is 50 mm x 50 mm. Thickness of copper layers are 53 μm /35 μm /35 μm /53 μm (1.5oz/1oz/1oz/1.5oz). Ambient temperature in simulation is 22°C, still air. Power dissipation is 1W. The value of θ_{JA} of this product in this DSBGA could fall in a range as wide as 50°C/W to 150°C/W (if not wider), depending on PWB material, layout, and environmental conditions. In applications where high maximum power dissipation exists (high V_{IN} , high I_{OUT}), special care must be paid to thermal dissipation issues.

Electrical Characteristics⁽¹⁾⁽²⁾

Limits in standard typeface are for $T_J = 25^\circ\text{C}$. Limits in **boldface** type apply over the full operating junction temperature range ($-40^\circ\text{C} \leq T_J \leq +125^\circ\text{C}$). Unless otherwise noted, specifications apply to the LM2758 Typical Application Circuit (pg.1) with $V_{IN} = 3.6\text{V}$, $V_{EN1} = V_{IN}$, $V_{EN2} = 0\text{V}$, $C1 = C2 = 1\ \mu\text{F}$, $C_{IN} = C_{OUT} = 2.2\ \mu\text{F}$, $R_{SET} = 20\ \text{k}\Omega$ ⁽³⁾.

Symbol	Parameter	Conditions	Min	Typ	Max	Units
I_{LED}	LED Current Accuracy	$I_{LED} = 500\ \text{mA}$, Flash Mode	450	500	550	mA
V_{SET}	I_{SET} Pin Voltage			1.3		V
I_D/I_{SET}	LED Current to Set Current Ratio	Flash Mode		7650		
		Torch Mode		1639		
$I_{LED-IND}$	Indicator Current Level	Indicator Mode 32 kHz PWM Mode		$1/32 \times I_{LED-TORCH}$		mA
V_{GDX}	1x to 1.5x Gain Transition Voltage Threshold on V_{LED-}	$I_{OUT} = 500\ \text{mA}$		300		mV
V_{OUT}	Output Voltage	1x Mode, $I_{OUT} = 0\ \text{mA}$		V_{IN}		V
		1.5x Mode, $I_{OUT} = 0\ \text{mA}$ ⁽⁴⁾		4.8	5.3	
R_{OUT}	1x Mode Output Impedance	$I_{OUT} = 200\ \text{mA}$, $V_{IN} = 3.3\text{V}$		0.33	0.53	Ω
	1.5x Mode Output Impedance	$I_{OUT} = 500\ \text{mA}$, $V_{IN} = 3.3\text{V}$ ⁽⁵⁾		1.5	2.0	
F_{SW}	Switching Frequency		0.8	1.25	1.5	MHz
I_Q	Quiescent Current	$I_{OUT} = 0\ \text{mA}$ 1x Mode		0.7	0.8	mA
		$I_{OUT} = 0\ \text{mA}$ 1.5x Mode		4	5	
I_{SD}	Shutdown Current	Device Disabled ⁽⁶⁾		0.01	1	μA
T_{OUT}	Time-out Duration	⁽⁷⁾	640	814	1000	msec
V_{IH}	Input Logic High	Pins: EN1, EN2	1.2			V
V_{IL}	Input Logic Low	Pins: EN1, EN2			0.4	V

- (1) All voltages are with respect to the potential to the GND pin.
- (2) Min and Max limits are guaranteed by design, test, or statistical analysis. Typical (Typ) numbers are not guaranteed, but do represent the most likely norm. Unless otherwise specified, conditions for Typ specifications are: $V_{IN} = 3.6\text{V}$ and $T_A = 25^\circ\text{C}$.
- (3) C_{IN} , C_{OUT} , C1, C2: Low-ESR Surface-Mount Ceramic Capacitors (MLCCs) used in setting electrical characteristics.
- (4) Output voltage is internally limited not to exceed maximum specified value.
- (5) These specification table entries are guaranteed by design. These parameters are not guaranteed by production testing. The temperature limits for test are ($-40^\circ\text{C} \leq T_A \leq +85^\circ\text{C}$).
- (6) The temperature limits for I_{SD} (shutdown current) test are $-40^\circ\text{C} \leq T_A \leq +85^\circ\text{C}$, as in Shutdown mode ambient temperature is equal to junction temperature.
- (7) The time-out specifications are calculated values based on the switching frequency spread.

BLOCK DIAGRAM

LM2758 Block Diagram

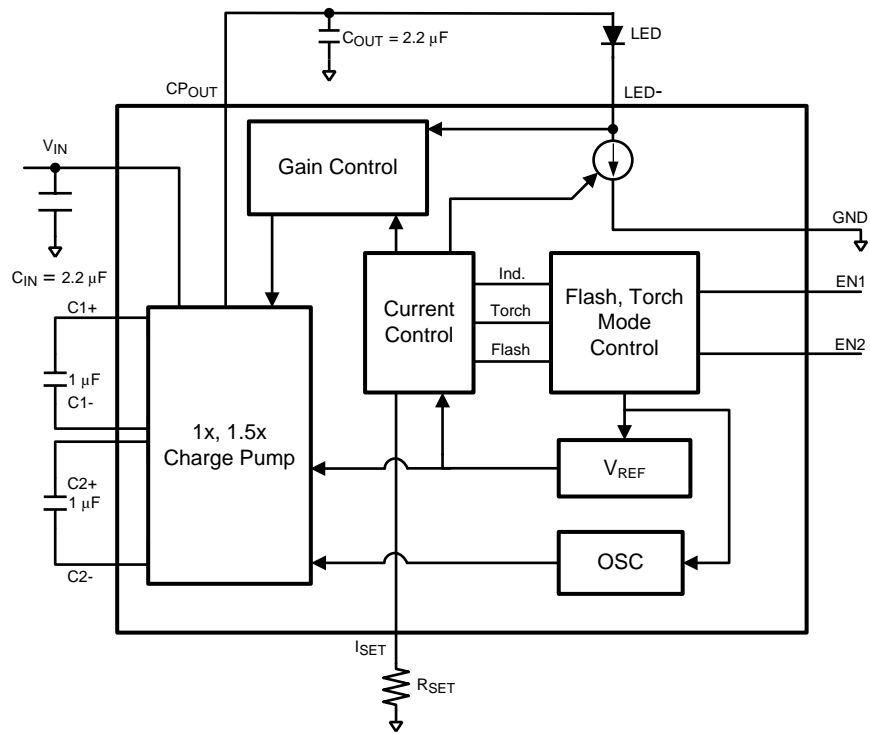

Typical Performance Characteristics

Unless otherwise specified: $T_A = 25^\circ\text{C}$, $V_{IN} = 3.6\text{V}$, $C_{IN} = C_{OUT} = 2.2\ \mu\text{F}$, $C1 = C2 = 1\ \mu\text{F}$. Capacitors are low-ESR multi-layer ceramic capacitors (MLCC's). Luxeon PWF1 Flash LED.

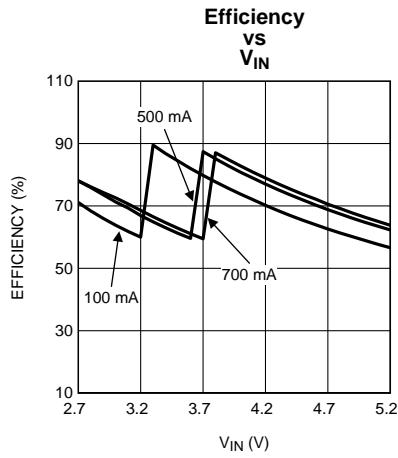

Figure 2.

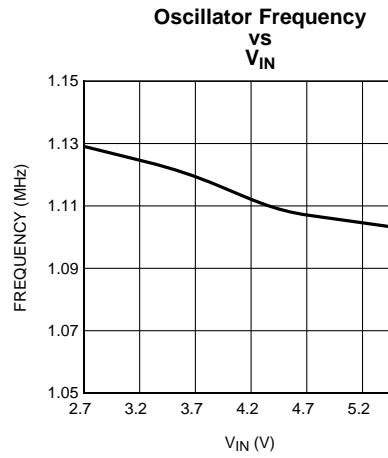

Figure 3.

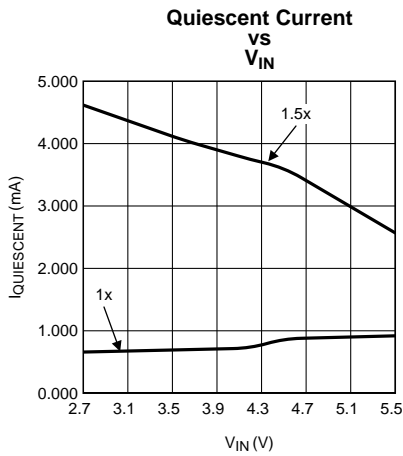

Figure 4.

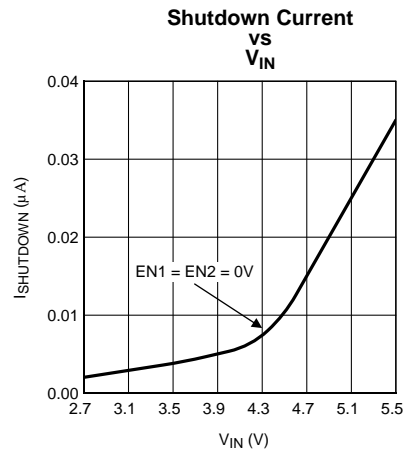

Figure 5.

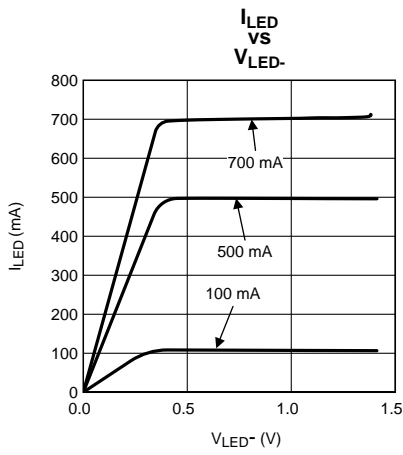

Figure 6.

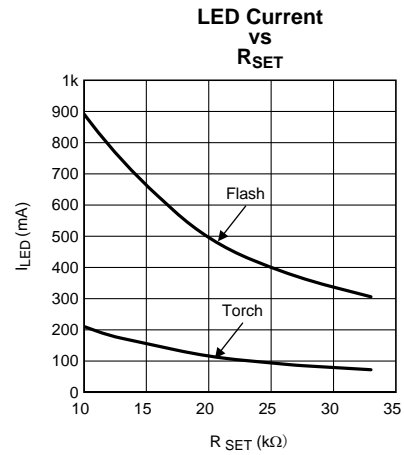

Figure 7.

Typical Performance Characteristics (continued)

Unless otherwise specified: $T_A = 25^\circ\text{C}$, $V_{IN} = 3.6\text{V}$, $C_{IN} = C_{OUT} = 2.2\ \mu\text{F}$, $C_1 = C_2 = 1\ \mu\text{F}$. Capacitors are low-ESR multi-layer ceramic capacitors (MLCC's). Luxeon PWF1 Flash LED.

Shutdown to Flash Mode
 $V_{IN} = 3.6\text{V}$, $I_{LED} = 500\ \text{mA}$

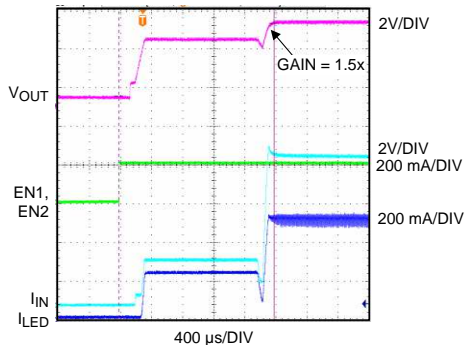

Figure 8.

Shutdown to Torch Mode
 $V_{IN} = 3.6\text{V}$, $I_{LED} = 108\ \text{mA}$, Gain = 1x, EN1 = 0V

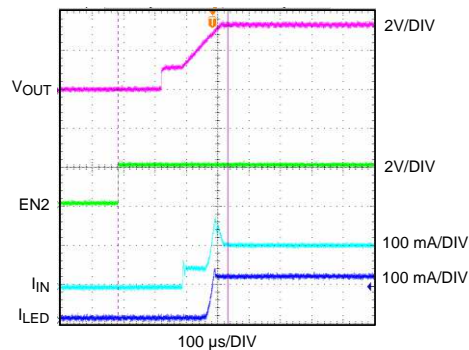

Figure 9.

Shutdown to Indicator Mode
 $V_{IN} = 3.6\text{V}$, $I_{LED}(\text{Torch}) = 108\ \text{mA}$, EN2 = 0V

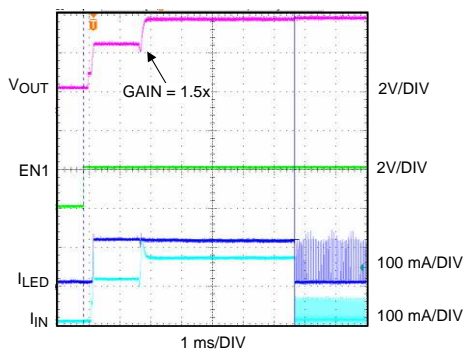

Figure 10.

Indicator Mode
 $EN1 = V_{IN} = 3.6\text{V}$, $I_{LED}(\text{Torch}) = 108\ \text{mA}$, Gain = 1x, EN2 = 0V

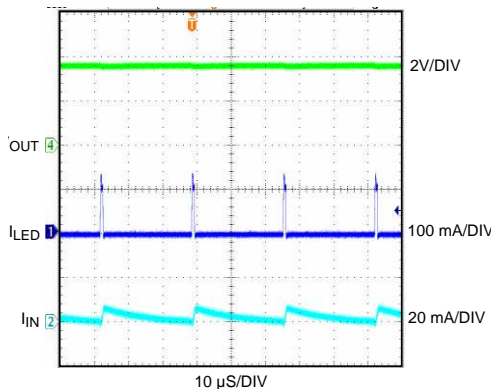

Figure 11.

Typical Performance Characteristics (continued)

Unless otherwise specified: $T_A = 25^\circ\text{C}$, $V_{IN} = 3.6\text{V}$, $C_{IN} = C_{OUT} = 2.2\ \mu\text{F}$, $C1 = C2 = 1\ \mu\text{F}$. Capacitors are low-ESR multi-layer ceramic capacitors (MLCC's). Luxeon PWF1 Flash LED.

Torch to Flash Mode Transition
 $EN2 = V_{IN} = 3.6\text{V}$, $I_{LED}(\text{Flash}) = 500\ \text{mA}$, Gain = 1.5x

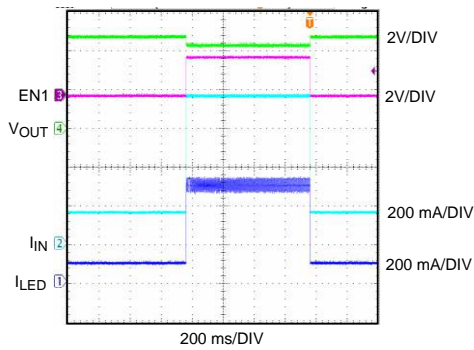

Figure 12.

Indicator to Flash Mode Transition
 $EN1 = V_{IN} = 3.6\text{V}$, $I_{LED}(\text{Flash}) = 500\ \text{mA}$, Gain = 1.5x

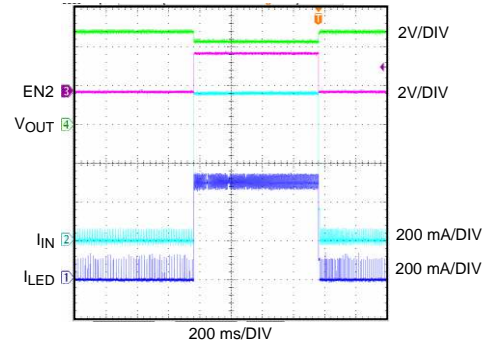

Figure 13.

APPLICATION INFORMATION

Circuit Description

The LM2758 is an adaptive 1x and 1.5x CMOS charge pump, optimized for driving Flash LEDs in camera phone and other portable applications. It provides a constant current of 500 mA (typ.) for Flash mode and 107 mA (typ.) for Torch mode with $R_{SET} = 20\text{ k}\Omega$. These current can change, see [Setting LED Currents](#).

There are four modes of operation for LM2758: the Flash Mode, Torch Mode, Indicator Mode and Shutdown Mode (see EN1 and EN2 truth table). Torch and Flash modes sink a constant DC current while Indicator mode operates in pulsating DC at 1/32 positive duty cycle with same current magnitude as Torch mode. The LED is driven from CP_{OUT} and connected to the current sink. LED drive current mode is programmed by connecting a resistor, R_{SET} , to the current set pin, I_{SET} . LM2758 also controls CP_{OUT} with variable gain (1x or 1.5x) and adjustable impedance (R_{OUT}) to provide an output voltage that would account for LED forward voltage drop and headroom for the current sink to drive desired current through LED.

Charge Pump and Gain Transitions

The input to the 1x/1.5x charge pump is connected to the V_{IN} pin, and the loosely regulated output of the charge pump is connected to the CP_{OUT} pin. In 1x mode, as long as the input voltage is less than 4.7V, the output voltage is approximately equal to the input voltage. When input voltage is over 4.7V the output voltage gets regulated to 4.7V. In 1.5x mode, the output voltage is always less than or equal to 4.7V over entire input voltage range.

The charge pump's gain is selected depending on the headroom voltage across the current sink of LM2758. When headroom voltage V_{LED} (at LED pin) drops below 300 mV (typ.) the charge pump gain transition happens from 1x to 1.5x to maintain current regulation across the LED. Once the charge pump transition to a higher gain, it will remain at that gain for as long as the device remains enabled. Shutting down and then re-enabling the device will resets the gain mode to the minimum gain required to maintain the load.

Soft Start

The LM2758 contains internal soft-start circuitry to limit inrush currents when the part is enabled. Soft start is implemented internally with a controlled turn-on of the internal voltage reference.

Current Limit Protection

The LM2758 charge pump contains current limit protection circuitry that protects the device during V_{OUT} fault conditions where excessive current is drawn. Output current is limited to 1.2A typically.

Logic Control Pins

LM2758 has two logic pins, EN1 and EN2. There is a 500 k Ω (typ.) pulldown resistor connected from EN1 to GND and from EN2 to GND. The operating modes of the part function according to the tables below:

EN1	EN2	Mode
0	0	Shutdown
1	0	Indicator
0	1	Torch
1	1	Flash

Flash Time-Out Feature

Flash Time-out Protection Circuitry disables the current sinks when the signal on EN1 and EN2 is held high for more than 814 msec (typ.). This prevents the device from self-heating due to the high power dissipation during Flash conditions. During the time-out condition, voltage will still be present on CP_{OUT} but the current sinks will be shut off, resulting in no current through the Flash LED. When the device goes into a time-out condition, placing a logic Low signal on EN1 and EN2 will reset the time-out; a subsequent logic High signal on EN1 or EN2 will return the device to normal operation.

Setting LED Currents

The current through the LED can be set by connecting an appropriately sized resistor R_{SET} between the I_{SET} pin of the LM2758 and GND.

The LED current in Torch mode is approximately 1639 times greater than the current of I_{SET} , while the LED current in Flash mode is approximately 7650 times of the same I_{SET} current. The feedback loop of an internal amplifier sets the voltage of the I_{SET} pin to 1.3V (typ.). The statements above are simplified in the equations below:

$$I_{LED} = GAIN_{FLASH/TORCH} \times (1.3/R_{SET}) \quad (1)$$

The maximum recommended current through LED is 500 mA in Torch mode / 700 mA in Flash mode. Note: If the I_{SET} for Torch Mode setting at 500 mA, the Flash mode would be over 700 mA (max). See the graph LED Current vs R_{SET} . Using the part in conditions where the junction temperature might rise above the rated maximum requires that the operating ranges and/or conditions be de-rated. The printed circuit board also must be carefully laid out to account for high thermal dissipation in the part.

Analog Brightness Control

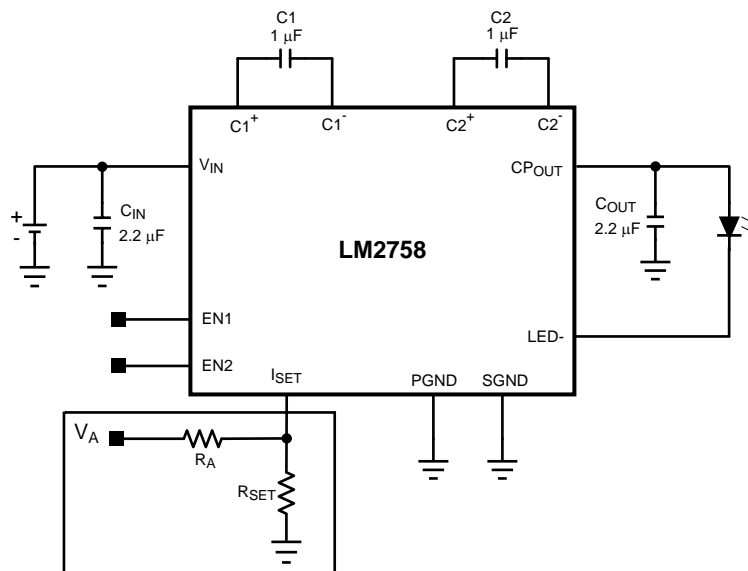

The current through the LED could be varied dynamically by changing the I_{SET} current. The above figure shows the circuit. The current through the LED can be calculated as follows.

$$I_{LED} = Gain_{TORCH/FLASH} \left[\frac{1.3V}{R_{SET}} - \frac{V_A - 1.3V}{R_A} \right]$$

Capacitor Selection

The LM2758 requires 4 external capacitors for proper operation. Surface-mount multi-layer ceramic capacitors are recommended. These capacitors are small, inexpensive and have very low equivalent series resistance (ESR <20 mΩ typ.). Tantalum capacitors, OS-CON capacitors, and aluminum electrolytic capacitors are not recommended for use with the LM2758 due to their high ESR, as compared to ceramic capacitors. For most applications, ceramic capacitors with X7R or X5R temperature characteristic are preferred for use with the LM2758. These capacitors have tight capacitance tolerance (as good as ±10%) and hold their value over temperature (X7R: ±15% over -55°C to 125°C; X5R: ±15% over -55°C to 85°C). Capacitors with Y5V or Z5U temperature characteristic are generally not recommended for use with the LM2758. Capacitors with these temperature characteristics typically have wide capacitance tolerance (+80%, -20%) and vary significantly over temperature (Y5V: +22%, -82% over -30°C to +85°C range; Z5U: +22%, -56% over +10°C to +85°C range). Under some conditions, a nominal 1 µF Y5V or Z5U capacitor could have a capacitance of only 0.1 µF. Such detrimental deviation is likely to cause Y5V and Z5U capacitors to fail to meet the minimum capacitance

requirements of the LM2758. The voltage rating of the output capacitor should be 6.3V or more. For example, a 6.3V 0603 2.2 μF output capacitor (TDK C1608X5R0J225) is acceptable for use with the LM2758, as long as the capacitance on the output does not fall below a minimum of 1 μF in the intended application. All other capacitors should have a voltage rating at or above the maximum input voltage of the application and should have a minimum capacitance of 1 μF .

Table 1. Suggested Capacitors and Suppliers

MFG Part No.	Type	MFG	Voltage Rating	Case Size Inch (mm)
2.2 μF for C_{IN} and C_{OUT}				
C1608X5R0J225	Ceramic X5R	TDK	6.3V	0603 (1608)
JMK107BJ225	Ceramic X5R	Taiyo-Yuden	6.3V	0603 (1608)
1 μF for C_1 and C_2				
C1608X5R0J105	Ceramic X5R	TDK	6.3V	0603 (1608)
JMK107BJ105M	Ceramic X5R	Taiyo-Yuden	6.3V	0603 (1608)

Power Efficiency

Efficiency of LED drivers is commonly taken to be the ratio of power consumed by the LEDs (P_{LED}) to the power drawn at the input of the part (P_{IN}). With a 1x/1.5x charge pump, the input current is equal to the charge pump gain times the output current (total LED current). The efficiency of the LM2758 can be predicted as follows:

$$P_{\text{LED}} = V_{\text{LED}} \times I_{\text{LED}} \quad (2)$$

$$P_{\text{IN}} = V_{\text{IN}} \times I_{\text{IN}} \quad (3)$$

$$P_{\text{IN}} = V_{\text{IN}} \times (\text{Gain} \times I_{\text{LED}} + I_{\text{Q}}) \quad (4)$$

$$E = (P_{\text{LED}} \div P_{\text{IN}}) \quad (5)$$

For a simple approximation, the current consumed by internal circuitry (I_{Q}) can be neglected, and the resulting efficiency will become:

$$E = V_{\text{LED}} \div (V_{\text{IN}} \times \text{Gain}) \quad (6)$$

Neglecting I_{Q} will result in a slightly higher efficiency prediction, but this impact will be negligible due to the value of I_{Q} being very low compared to the typical Torch and Flash current levels (100-500 mA). It is also worth noting that efficiency as defined here is in part dependent on LED voltage. Variation in LED voltage does not affect power consumed by the circuit and typically does not relate to the brightness of the LED. For an advanced analysis, it is recommended that power consumed by the circuit ($V_{\text{IN}} \times I_{\text{IN}}$) be evaluated rather than power efficiency.

Thermal Protection

Internal thermal protection circuitry disables the LM2758 when the junction temperature exceeds 150°C (typ.). This feature protects the device from being damaged by high die temperatures that might otherwise result from excessive power dissipation. The device will recover and operate normally when the junction temperature falls below 140°C (typ.). It is important that the board layout provide good thermal conduction to keep the junction temperature within the specified operating ratings.

Power Dissipation

The power dissipation ($P_{\text{DISSIPATION}}$) and junction temperature (T_{J}) can be approximated with the equations below. P_{IN} is the power generated by the 1x/1.5x charge pump, P_{LED} is the power consumed by the LEDs, T_{A} is the ambient temperature, and θ_{JA} is the junction-to-ambient thermal resistance for the 12-bump DSBGA package. V_{IN} is the input voltage to the LM2758, V_{LED} is the nominal LED forward voltage, and I_{LED} is the programmed LED current.

$$P_{\text{DISSIPATION}} = P_{\text{IN}} - P_{\text{LED}} \quad (7)$$

$$= (\text{Gain} \times V_{\text{IN}} \times I_{\text{LED}}) - (V_{\text{LED}} \times I_{\text{LED}}) \quad (8)$$

$$T_{\text{J}} = T_{\text{A}} + (P_{\text{DISSIPATION}} \times \theta_{\text{JA}}) \quad (9)$$

The junction temperature rating takes precedence over the ambient temperature rating. The LM2758 may be operated outside the ambient temperature rating, so long as the junction temperature of the device does not exceed the maximum operating rating of 125°C. The maximum ambient temperature rating must be derated in applications where high power dissipation and/or poor thermal resistance causes the junction temperature to exceed 125°C.

DSBGA Package Assembly and Use



Use of the DSBGA package requires specialized board layout, precision mounting and careful re-flow techniques as detailed in Texas Instruments Application Note 1112. Refer to the section "Surface Mount Assembly Considerations". For best results in assembly, alignment ordinals on the PC board should be used to facilitate placement of the device. The pad style used with the DSBGA package must be the NSMD (non-solder mask defined) typ. This means that the solder-mask opening is larger than the pad size. This prevents a lip that otherwise forms if the solder mask and pad overlap, from holding the device off the surface of the board and interfering with mounting. See Application Note 1112 for specific instructions how to do this. The 12-bump package used for LM2758 has 300 micron solder balls and requires 10.82 mils pads for mounting on the circuit board. The trace to each pad should enter the pad with a 90° entry angle to prevent debris from being caught in deep corners. Initially, the trace to each pad should be 7 mil. wide, for a section approximately 7 mil. long or longer, as a thermal relief. Then each trace should neck up or down to its optimal width. The important criteria is symmetry. This ensures the solder bumps on the LM2758 re-flow evenly and that the device solders level to the board. In particular, special attention must be paid to the pads for bumps C1 and D3, because V_{IN} and GND are typically connected to large copper planes, thus inadequate thermal relief can result in late or inadequate re-flow of these bumps.

The DSBGA package is optimized for the smallest possible size in applications with red or infrared opaque cases. Because the DSBGA package lacks the plastic encapsulation characteristic of larger devices, it is vulnerable to light. Backside metallization and/or epoxy coating, along with front side shading by the printed circuit board, reduce this sensitivity. However, the package has exposed die edges. In particular, DSBGA devices are sensitive to light, in the red and infrared range, shining on the package's exposed die edges.

Board Layout Considerations

PC board layout is an important part of DC-DC converter design. Poor board layout can disrupt the performance of a DC-DC converter and surrounding circuitry by contributing to EMI, ground bounce, and resistive voltage loss in the traces. These can send erroneous signals to the DC-DC converter IC, resulting in poor regulation or instability. Poor layout can also result in re-flow problems leading to poor solder joints between the DSBGA package and board pads. Poor solder joints can result in erratic or degraded performance.

PACKAGING INFORMATION

Orderable Device	Status (1)	Package Type	Package Drawing	Pins	Package Qty	Eco Plan (2)	Lead/Ball Finish	MSL Peak Temp (3)	Op Temp (°C)	Top-Side Markings (4)	Samples
LM2758TL/NOPB	ACTIVE	DSBGA	YZR	12	250	Green (RoHS & no Sb/Br)	SNAGCU	Level-1-260C-UNLIM	-40 to 85	2758	
LM2758TLX/NOPB	ACTIVE	DSBGA	YZR	12	3000	Green (RoHS & no Sb/Br)	SNAGCU	Level-1-260C-UNLIM	-40 to 85	2758	

(1) The marketing status values are defined as follows:

ACTIVE: Product device recommended for new designs.

LIFEBUY: TI has announced that the device will be discontinued, and a lifetime-buy period is in effect.

NRND: Not recommended for new designs. Device is in production to support existing customers, but TI does not recommend using this part in a new design.

PREVIEW: Device has been announced but is not in production. Samples may or may not be available.

OBSOLETE: TI has discontinued the production of the device.

(2) Eco Plan - The planned eco-friendly classification: Pb-Free (RoHS), Pb-Free (RoHS Exempt), or Green (RoHS & no Sb/Br) - please check <http://www.ti.com/productcontent> for the latest availability information and additional product content details.

TBD: The Pb-Free/Green conversion plan has not been defined.

Pb-Free (RoHS): TI's terms "Lead-Free" or "Pb-Free" mean semiconductor products that are compatible with the current RoHS requirements for all 6 substances, including the requirement that lead not exceed 0.1% by weight in homogeneous materials. Where designed to be soldered at high temperatures, TI Pb-Free products are suitable for use in specified lead-free processes.

Pb-Free (RoHS Exempt): This component has a RoHS exemption for either 1) lead-based flip-chip solder bumps used between the die and package, or 2) lead-based die adhesive used between the die and leadframe. The component is otherwise considered Pb-Free (RoHS compatible) as defined above.

Green (RoHS & no Sb/Br): TI defines "Green" to mean Pb-Free (RoHS compatible), and free of Bromine (Br) and Antimony (Sb) based flame retardants (Br or Sb do not exceed 0.1% by weight in homogeneous material)

(3) MSL, Peak Temp. -- The Moisture Sensitivity Level rating according to the JEDEC industry standard classifications, and peak solder temperature.

(4) Only one of markings shown within the brackets will appear on the physical device.

Important Information and Disclaimer: The information provided on this page represents TI's knowledge and belief as of the date that it is provided. TI bases its knowledge and belief on information provided by third parties, and makes no representation or warranty as to the accuracy of such information. Efforts are underway to better integrate information from third parties. TI has taken and continues to take reasonable steps to provide representative and accurate information but may not have conducted destructive testing or chemical analysis on incoming materials and chemicals. TI and TI suppliers consider certain information to be proprietary, and thus CAS numbers and other limited information may not be available for release.

In no event shall TI's liability arising out of such information exceed the total purchase price of the TI part(s) at issue in this document sold by TI to Customer on an annual basis.

TAPE AND REEL INFORMATION

QUADRANT ASSIGNMENTS FOR PIN 1 ORIENTATION IN TAPE

*All dimensions are nominal

Device	Package Type	Package Drawing	Pins	SPQ	Reel Diameter (mm)	Reel Width W1 (mm)	A0 (mm)	B0 (mm)	K0 (mm)	P1 (mm)	W (mm)	Pin1 Quadrant
LM2758TL/NOPB	DSBGA	YZR	12	250	178.0	8.4	1.68	2.13	0.76	4.0	8.0	Q1
LM2758TLX/NOPB	DSBGA	YZR	12	3000	178.0	8.4	1.68	2.13	0.76	4.0	8.0	Q1

TAPE AND REEL BOX DIMENSIONS

*All dimensions are nominal

Device	Package Type	Package Drawing	Pins	SPQ	Length (mm)	Width (mm)	Height (mm)
LM2758TL/NOPB	DSBGA	YZR	12	250	203.0	190.0	41.0
LM2758TLX/NOPB	DSBGA	YZR	12	3000	206.0	191.0	90.0

YZR0012

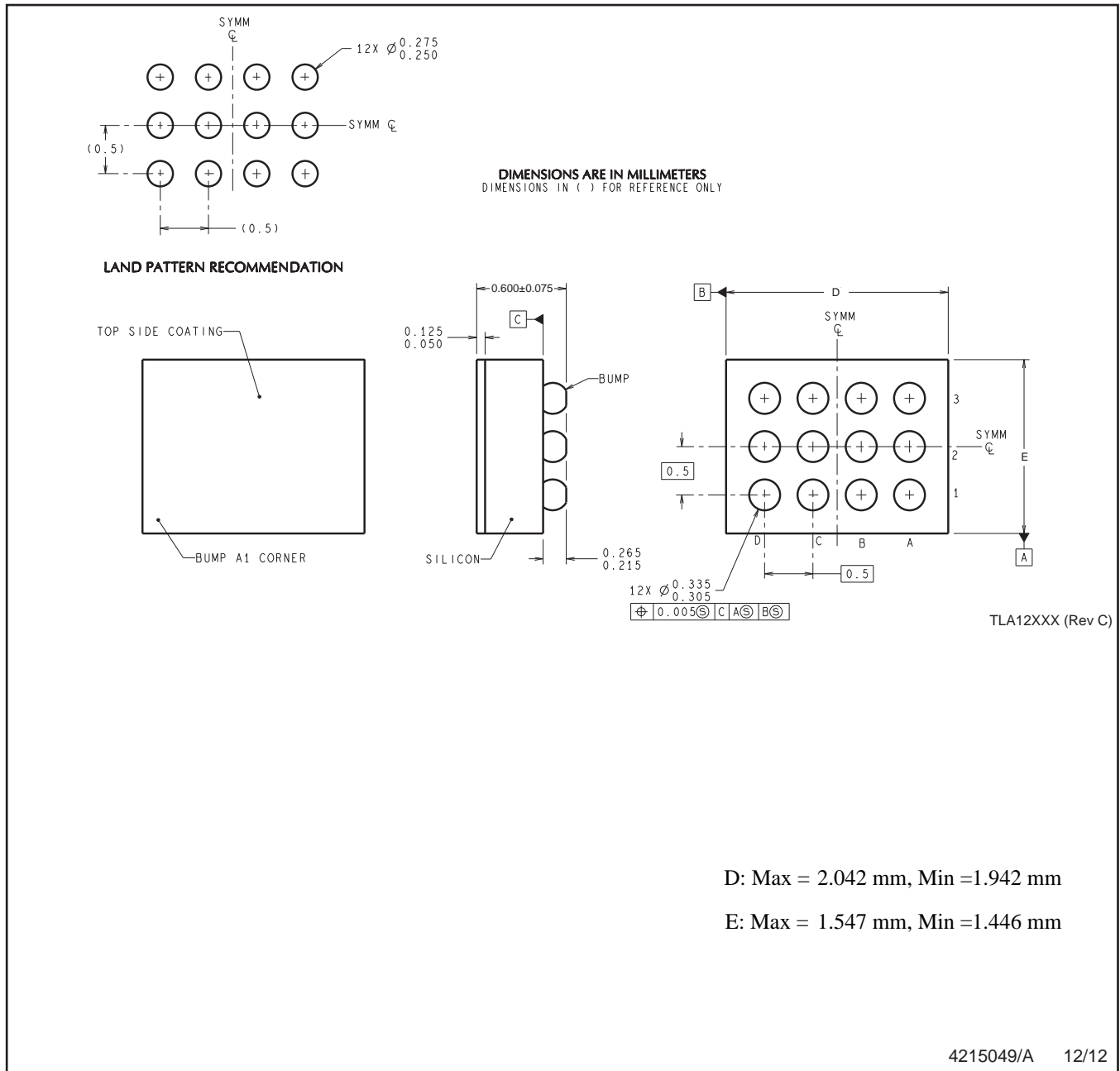

NOTES: A. All linear dimensions are in millimeters. Dimensioning and tolerancing per ASME Y14.5M-1994.
B. This drawing is subject to change without notice.

IMPORTANT NOTICE

Texas Instruments Incorporated and its subsidiaries (TI) reserve the right to make corrections, enhancements, improvements and other changes to its semiconductor products and services per JESD46, latest issue, and to discontinue any product or service per JESD48, latest issue. Buyers should obtain the latest relevant information before placing orders and should verify that such information is current and complete. All semiconductor products (also referred to herein as "components") are sold subject to TI's terms and conditions of sale supplied at the time of order acknowledgment.

TI warrants performance of its components to the specifications applicable at the time of sale, in accordance with the warranty in TI's terms and conditions of sale of semiconductor products. Testing and other quality control techniques are used to the extent TI deems necessary to support this warranty. Except where mandated by applicable law, testing of all parameters of each component is not necessarily performed.

TI assumes no liability for applications assistance or the design of Buyers' products. Buyers are responsible for their products and applications using TI components. To minimize the risks associated with Buyers' products and applications, Buyers should provide adequate design and operating safeguards.

TI does not warrant or represent that any license, either express or implied, is granted under any patent right, copyright, mask work right, or other intellectual property right relating to any combination, machine, or process in which TI components or services are used. Information published by TI regarding third-party products or services does not constitute a license to use such products or services or a warranty or endorsement thereof. Use of such information may require a license from a third party under the patents or other intellectual property of the third party, or a license from TI under the patents or other intellectual property of TI.

Reproduction of significant portions of TI information in TI data books or data sheets is permissible only if reproduction is without alteration and is accompanied by all associated warranties, conditions, limitations, and notices. TI is not responsible or liable for such altered documentation. Information of third parties may be subject to additional restrictions.

Resale of TI components or services with statements different from or beyond the parameters stated by TI for that component or service voids all express and any implied warranties for the associated TI component or service and is an unfair and deceptive business practice. TI is not responsible or liable for any such statements.

Buyer acknowledges and agrees that it is solely responsible for compliance with all legal, regulatory and safety-related requirements concerning its products, and any use of TI components in its applications, notwithstanding any applications-related information or support that may be provided by TI. Buyer represents and agrees that it has all the necessary expertise to create and implement safeguards which anticipate dangerous consequences of failures, monitor failures and their consequences, lessen the likelihood of failures that might cause harm and take appropriate remedial actions. Buyer will fully indemnify TI and its representatives against any damages arising out of the use of any TI components in safety-critical applications.

In some cases, TI components may be promoted specifically to facilitate safety-related applications. With such components, TI's goal is to help enable customers to design and create their own end-product solutions that meet applicable functional safety standards and requirements. Nonetheless, such components are subject to these terms.

No TI components are authorized for use in FDA Class III (or similar life-critical medical equipment) unless authorized officers of the parties have executed a special agreement specifically governing such use.

Only those TI components which TI has specifically designated as military grade or "enhanced plastic" are designed and intended for use in military/aerospace applications or environments. Buyer acknowledges and agrees that any military or aerospace use of TI components which have **not** been so designated is solely at the Buyer's risk, and that Buyer is solely responsible for compliance with all legal and regulatory requirements in connection with such use.

TI has specifically designated certain components as meeting ISO/TS16949 requirements, mainly for automotive use. In any case of use of non-designated products, TI will not be responsible for any failure to meet ISO/TS16949.

Products

Audio	www.ti.com/audio
Amplifiers	amplifier.ti.com
Data Converters	dataconverter.ti.com
DLP® Products	www.dlp.com
DSP	dsp.ti.com
Clocks and Timers	www.ti.com/clocks
Interface	interface.ti.com
Logic	logic.ti.com
Power Mgmt	power.ti.com
Microcontrollers	microcontroller.ti.com
RFID	www.ti-rfid.com
OMAP Applications Processors	www.ti.com/omap
Wireless Connectivity	www.ti.com/wirelessconnectivity

Applications

Automotive and Transportation	www.ti.com/automotive
Communications and Telecom	www.ti.com/communications
Computers and Peripherals	www.ti.com/computers
Consumer Electronics	www.ti.com/consumer-apps
Energy and Lighting	www.ti.com/energy
Industrial	www.ti.com/industrial
Medical	www.ti.com/medical
Security	www.ti.com/security
Space, Avionics and Defense	www.ti.com/space-avionics-defense
Video and Imaging	www.ti.com/video

TI E2E Community

e2e.ti.com