

LM2717 Dual Step-Down DC/DC Converter

Check for Samples: [LM2717](#)

FEATURES

- Fixed 3.3V Output Buck Converter with a 2.2A, 0.16Ω, Internal Switch
- Adjustable Buck Converter with a 3.2A, 0.16Ω, Internal Switch
- Operating Input Voltage Range of 4V to 20V
- Input Undervoltage Protection
- 300kHz to 600kHz Pin Adjustable Operating Frequency
- Over Temperature Protection
- Small 24-Lead TSSOP Package

APPLICATIONS

- TFT-LCD Displays
- Handheld Devices

- Portable Applications
- Laptop Computers

DESCRIPTION

The LM2717 is composed of two PWM DC/DC buck (step-down) converters. The first converter is used to generate a fixed output voltage of 3.3V. The second converter is used to generate an adjustable output voltage. Both converters feature low $R_{\text{DS(on)}}$ (0.16Ω) internal switches for maximum efficiency. Operating frequency can be adjusted anywhere between 300kHz and 600kHz allowing the use of small external components. External soft-start pins for each enables the user to tailor the soft-start times to a specific application. Each converter may also be shut down independently with its own shutdown pin. The LM2717 is available in a low profile 24-lead TSSOP package ensuring a low profile overall solution.

Typical Application Circuit

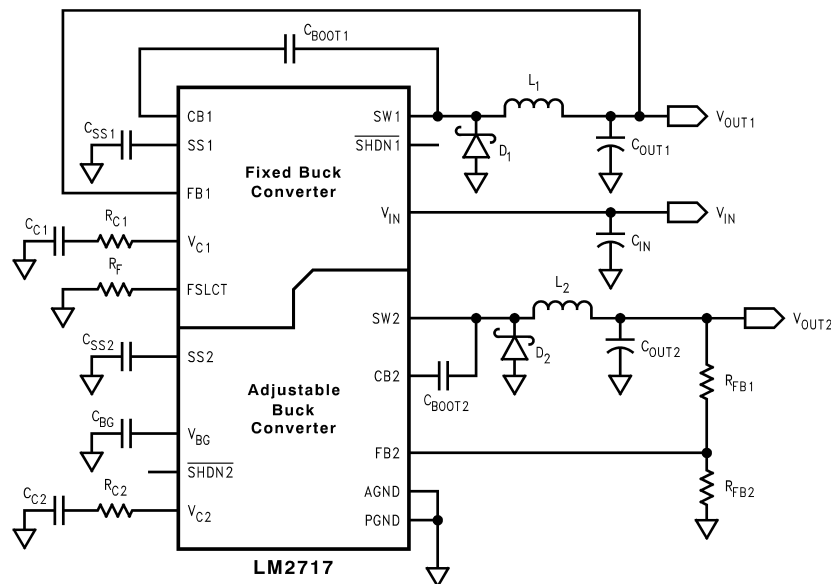

Please be aware that an important notice concerning availability, standard warranty, and use in critical applications of Texas Instruments semiconductor products and disclaimers thereto appears at the end of this data sheet.

All trademarks are the property of their respective owners.

Connection Diagram

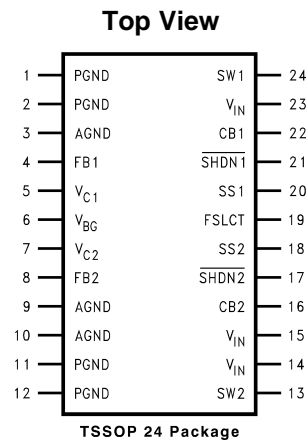

Figure 1. 24-Lead TSSOP
See Package Number PW0024A

PIN DESCRIPTIONS

Pin	Name	Function
1	PGND	Power ground. PGND and AGND pins must be connected together directly at the part.
2	PGND	Power ground. PGND and AGND pins must be connected together directly at the part.
3	AGND	Analog ground. PGND and AGND pins must be connected together directly at the part.
4	FB1	Fixed buck output voltage feedback input.
5	VC1	Fixed buck compensation network connection. Connected to the output of the voltage error amplifier.
6	VBG	Bandgap connection.
7	VC2	Adjustable buck compensation network connection. Connected to the output of the voltage error amplifier.
8	FB2	Adjustable buck output voltage feedback input.
9	AGND	Analog ground. PGND and AGND pins must be connected together directly at the part.
10	AGND	Analog ground. PGND and AGND pins must be connected together directly at the part.
11	PGND	Power ground. PGND and AGND pins must be connected together directly at the part.
12	PGND	Power ground. PGND and AGND pins must be connected together directly at the part.
13	SW2	Adjustable buck power switch input. Switch connected between VIN pins and SW2 pin.
14	VIN	Analog power input. VIN pins should be connected together directly at the part.
15	VIN	Analog power input. VIN pins should be connected together directly at the part.
16	CB2	Adjustable buck converter bootstrap capacitor connection.
17	SHDN2	Shutdown pin for adjustable buck converter. Active low.
18	SS2	Adjustable buck soft start pin.
19	FSLCT	Switching frequency select input. Use a resistor to set the frequency anywhere between 300kHz and 600kHz.
20	SS1	Fixed buck soft start pin.
21	SHDN1	Shutdown pin for fixed buck converter. Active low.
22	CB1	Fixed buck converter bootstrap capacitor connection.
23	VIN	Analog power input. VIN pins should be connected together directly at the part.
24	SW1	Fixed buck power switch input. Switch connected between VIN pins and SW1 pin.

Absolute Maximum Ratings⁽¹⁾⁽²⁾

V_{IN}		-0.3V to 22V
SW1 Voltage		-0.3V to 22V
SW2 Voltage		-0.3V to 22V
FB1, FB2 Voltages		-0.3V to 7V
CB1, CB2 Voltages		-0.3V to $V_{IN}+7V$ ($V_{IN}=V_{SW}$)
V_{C1} Voltage		$1.75V \leq V_{C1} \leq 2.25V$
V_{C2} Voltage		$0.965V \leq V_{C2} \leq 1.565V$
$\overline{SHDN1}$ Voltage		-0.3V to 7.5V
$\overline{SHDN2}$ Voltage		-0.3V to 7.5V
SS1 Voltage		-0.3V to 2.1V
SS2 Voltage		-0.3V to 2.1V
FSLCT Voltage		AGND to 5V
Maximum Junction Temperature		150°C
Power Dissipation ⁽³⁾		Internally Limited
Lead Temperature		300°C
Vapor Phase (60 sec.)		215°C
Infrared (15 sec.)		220°C
ESD Susceptibility ⁽⁴⁾	Human Body Model	2kV

- (1) Absolute maximum ratings are limits beyond which damage to the device may occur. Operating Ratings are conditions for which the device is intended to be functional, but device parameter specifications may not be guaranteed. For guaranteed specifications and test conditions, see the [Electrical Characteristics](#).
- (2) If Military/Aerospace specified devices are required, please contact the Texas Instruments Sales Office/ Distributors for availability and specifications.
- (3) The maximum allowable power dissipation is a function of the maximum junction temperature, $T_J(\text{MAX})$, the junction-to-ambient thermal resistance, θ_{JA} , and the ambient temperature, T_A . See the Electrical Characteristics table for the thermal resistance. The maximum allowable power dissipation at any ambient temperature is calculated using: $P_D(\text{MAX}) = (T_{J(\text{MAX})} - T_A)/\theta_{JA}$. Exceeding the maximum allowable power dissipation will cause excessive die temperature, and the regulator will go into thermal shutdown.
- (4) The human body model is a 100 pF capacitor discharged through a 1.5k Ω resistor into each pin.

Operating Conditions

Operating Junction Temperature Range ⁽¹⁾	-40°C to +125°C
Storage Temperature	-65°C to +150°C
Supply Voltage	4V to 20V
SW1 Voltage	20V
SW2 Voltage	20V

- (1) All limits guaranteed at room temperature (standard typeface) and at temperature extremes (bold typeface). All room temperature limits are 100% tested or guaranteed through statistical analysis. All limits at temperature extremes are guaranteed via correlation using standard Statistical Quality Control (SQC) methods. All limits are used to calculate Average Outgoing Quality Level (AOQL).

Electrical Characteristics

Specifications in standard type face are for $T_J = 25^\circ\text{C}$ and those with **boldface type** apply over the full **Operating Temperature Range** ($T_J = -40^\circ\text{C}$ to $+125^\circ\text{C}$). $V_{IN} = 5\text{V}$, $I_L = 0\text{A}$, and $F_{SW} = 300\text{kHz}$ unless otherwise specified.

Symbol	Parameter	Conditions	Min ⁽¹⁾	Typ ⁽²⁾	Max ⁽¹⁾	Units
I_Q	Total Quiescent Current (both switchers)	Not Switching		2.7	6	mA
		Switching, switch open		6	12	mA
		$V_{\overline{SHDN}} = 0\text{V}$		9	27	μA
V_{FB1}	Fixed Buck Feedback Voltage			3.3		V
V_{FB2}	Adjustable Buck Feedback Voltage			1.267		V

- (1) All limits guaranteed at room temperature (standard typeface) and at temperature extremes (bold typeface). All room temperature limits are 100% tested or guaranteed through statistical analysis. All limits at temperature extremes are guaranteed via correlation using standard Statistical Quality Control (SQC) methods. All limits are used to calculate Average Outgoing Quality Level (AOQL).
- (2) Typical numbers are at 25°C and represent the most likely norm.

Electrical Characteristics (continued)

Specifications in standard type face are for $T_J = 25^\circ\text{C}$ and those with **boldface type** apply over the full **Operating Temperature Range** ($T_J = -40^\circ\text{C}$ to $+125^\circ\text{C}$). $V_{IN} = 5\text{V}$, $I_L = 0\text{A}$, and $F_{SW} = 300\text{kHz}$ unless otherwise specified.

Symbol	Parameter	Conditions	Min ⁽¹⁾	Typ ⁽²⁾	Max ⁽¹⁾	Units
$I_{CL1}^{(3)}$	Fixed Buck Switch Current Limit	$V_{IN} = 8\text{V}^{(4)}$		2.2		A
$I_{CL2}^{(3)}$	Adjustable Buck Switch Current Limit	$V_{IN} = 8\text{V}^{(4)}$		3.2		A
I_{B1}	Fixed Buck FB Pin Bias Current ⁽⁵⁾	$V_{IN} = 20\text{V}$		65		μA
I_{B2}	Adjustable Buck FB Pin Bias Current ⁽⁵⁾	$V_{IN} = 20\text{V}$		65		nA
V_{IN}	Input Voltage Range		4		20	V
g_{m1}	Fixed Buck Error Amp Transconductance	$\Delta I = 20\mu\text{A}$		1340		μmho
g_{m2}	Adjustable Buck Error Amp Transconductance	$\Delta I = 20\mu\text{A}$		1360		μmho
A_{V1}	Fixed Buck Error Amp Voltage Gain			134		V/V
A_{V2}	Adjustable Buck Error Amp Voltage Gain			136		V/V
D_{MAX}	Maximum Duty Cycle		89	93		%
F_{SW}	Switching Frequency	$R_F = 46.4\text{k}$	200	300	400	kHz
		$R_F = 22.6\text{k}$	475	600	775	
I_{SHDN1}	Fixed Buck Shutdown Pin Current	$0\text{V} < \sqrt{V_{SHDN1}} < 7.5\text{V}$	-5		5	μA
I_{SHDN2}	Adjustable Buck Shutdown Pin Current	$0\text{V} < \sqrt{V_{SHDN2}} < 7.5\text{V}$	-5		5	μA
I_{L1}	Fixed Buck Switch Leakage Current	$V_{IN} = 20\text{V}$		0.01	5	μA
I_{L2}	Adjustable Buck Switch Leakage Current	$V_{IN} = 20\text{V}$		0.01	5	μA
R_{DSON1}	Fixed Buck Switch $R_{DSON}^{(6)}$			160		m Ω
R_{DSON2}	Adjustable Buck Switch $R_{DSON}^{(6)}$			160		m Ω
Th_{SHDN1}	Fixed Buck $\overline{\text{SHDN}}$ Threshold	Output High	1.8	1.36		V
		Output Low		1.33	0.7	
Th_{SHDN2}	Adjustable Buck $\overline{\text{SHDN}}$ Threshold	Output High	1.8	1.36		V
		Output Low		1.33	0.7	
I_{SS1}	Fixed Buck Soft Start Pin Current		4	9	15	μA
I_{SS2}	Adjustable Buck Soft Start Pin Current		4	9	15	μA
UVP	On Threshold		4	3.8		V
	Off Threshold			3.6	3.3	
θ_{JA}	Thermal Resistance ⁽⁷⁾	TSSOP, package only		115		$^\circ\text{C/W}$

(3) Duty cycle affects current limit due to ramp generator.

(4) Current limit at 0% duty cycle. See *TYPICAL PERFORMANCE* section for Switch Current Limit vs. V_{IN}

(5) Bias current flows into FB pin.

(6) Includes the bond wires, R_{DSON} from V_{IN} pin(s) to SW pin.

(7) Refer to Texas Instruments packaging website for more detailed thermal information and mounting techniques for the TSSOP package.

Typical Performance Characteristics

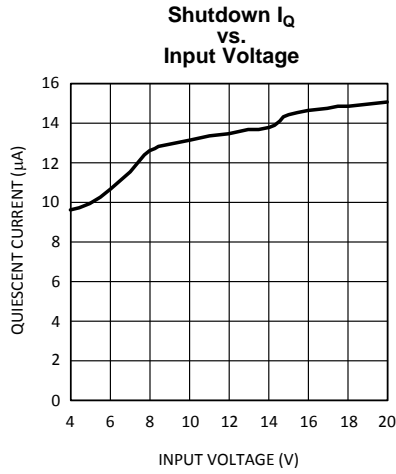

Figure 2.

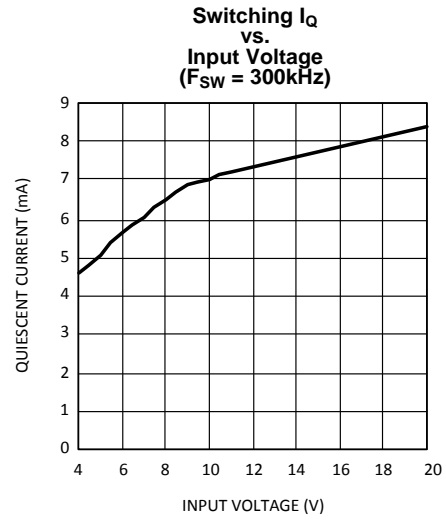

Figure 3.

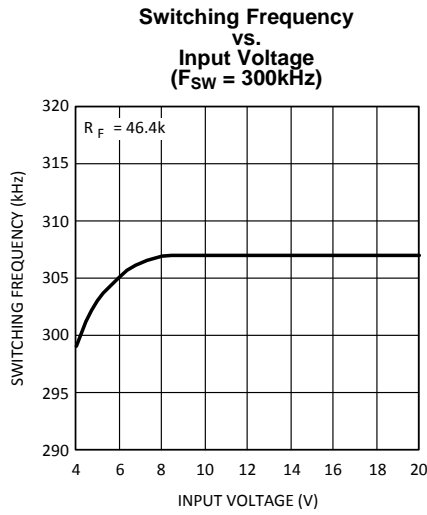

Figure 4.

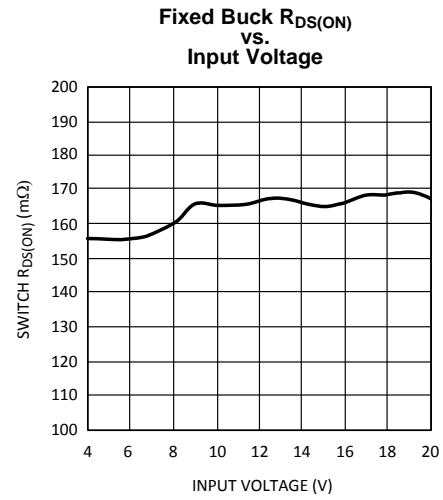

Figure 5.

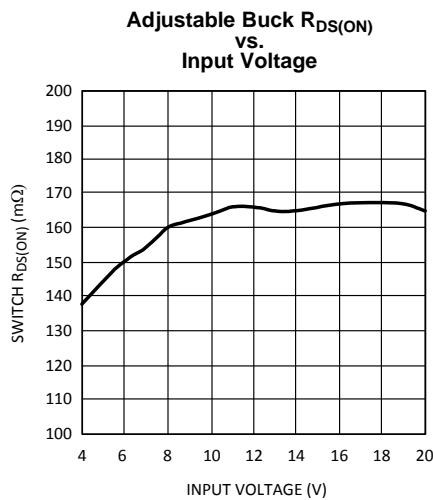

Figure 6.

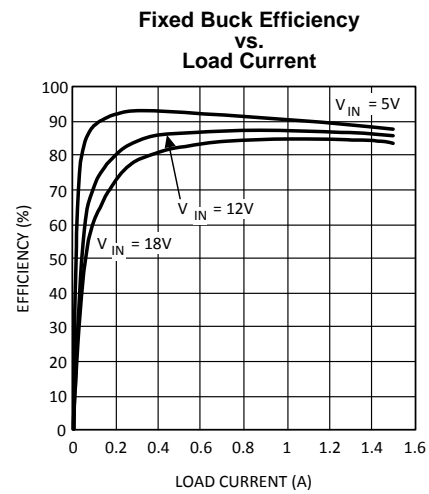

Figure 7.

Typical Performance Characteristics (continued)

Adjustable Buck Efficiency vs. Load Current (V_{OUT} = 15V)

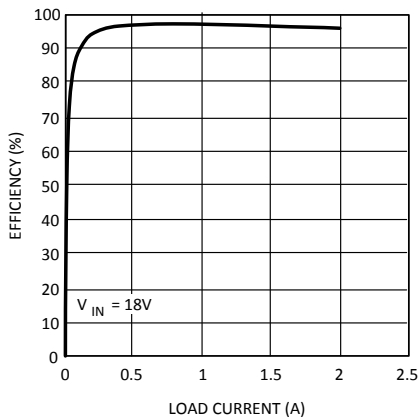

Figure 8.

Adjustable Buck Efficiency vs. Load Current (V_{OUT} = 5V)

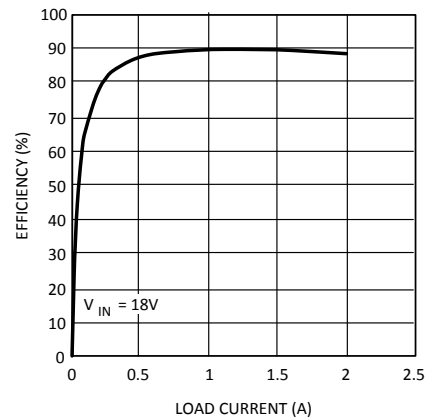

Figure 9.

Fixed Buck Switch Current Limit vs. Input Voltage

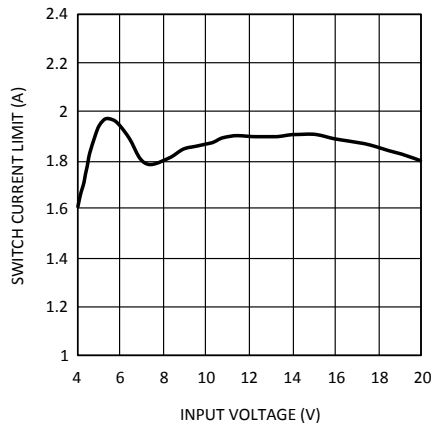

Figure 10.

Adjustable Buck Switch Current Limit vs. Input Voltage (V_{OUT} = 5V)

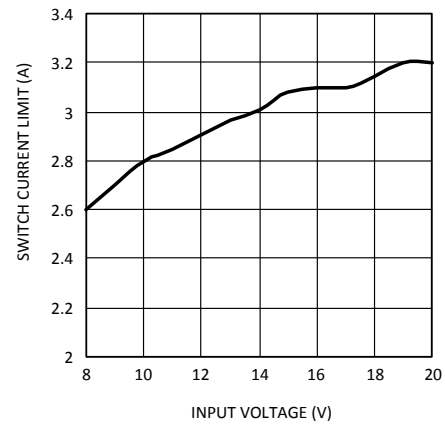

Figure 11.

BUCK OPERATION

PROTECTION (BOTH REGULATORS)

The LM2717 has dedicated protection circuitry running during normal operation to protect the IC. The Thermal Shutdown circuitry turns off the power devices when the die temperature reaches excessive levels. The UVP comparator protects the power devices during supply power startup and shutdown to prevent operation at voltages less than the minimum input voltage. The OVP comparator is used to prevent the output voltage from rising at no loads allowing full PWM operation over all load conditions. The LM2717 also features a shutdown mode for each converter decreasing the supply current to approximately 10µA (both in shutdown mode).

CONTINUOUS CONDUCTION MODE

The LM2717 contains current-mode, PWM buck regulators. A buck regulator steps the input voltage down to a lower output voltage. In continuous conduction mode (when the inductor current never reaches zero at steady state), the buck regulator operates in two cycles. The power switch is connected between V_{IN} and SW1 and SW2.

In the first cycle of operation the transistor is closed and the diode is reverse biased. Energy is collected in the inductor and the load current is supplied by C_{OUT} and the rising current through the inductor.

During the second cycle the transistor is open and the diode is forward biased due to the fact that the inductor current cannot instantaneously change direction. The energy stored in the inductor is transferred to the load and output capacitor.

The ratio of these two cycles determines the output voltage. The output voltage is defined approximately as:

$$D = \frac{V_{OUT}}{V_{IN}}, D' = (1-D) \quad (1)$$

where D is the duty cycle of the switch, D and D' will be required for design calculations.

DESIGN PROCEDURE

This section presents guidelines for selecting external components.

SETTING THE OUTPUT VOLTAGE (ADJUSTABLE REGULATOR)

The output voltage is set using the feedback pin and a resistor divider connected to the output as shown in [Figure 12](#). The feedback pin voltage is 1.26V, so the ratio of the feedback resistors sets the output voltage according to the following equation:

$$R_{FB1} = R_{FB2} \times \frac{V_{OUT} - 1.267}{1.267} \Omega \quad (2)$$

INPUT CAPACITOR

A low ESR aluminum, tantalum, or ceramic capacitor is needed between the input pin and power ground. This capacitor prevents large voltage transients from appearing at the input. The capacitor is selected based on the RMS current and voltage requirements. The RMS current is given by:

$$I_{RMS} = I_{OUT} \times \frac{\sqrt{V_{OUT}(V_{IN} - V_{OUT})}}{V_{IN}} \quad (3)$$

The RMS current reaches its maximum ($I_{OUT}/2$) when V_{IN} equals $2V_{OUT}$. This value should be calculated for both regulators and added to give a total RMS current rating. For an aluminum or ceramic capacitor, the voltage rating should be at least 25% higher than the maximum input voltage. If a tantalum capacitor is used, the voltage rating required is about twice the maximum input voltage. The tantalum capacitor should be surge current tested by the manufacturer to prevent being shorted by the inrush current. The minimum capacitor value should be 47µF for lower output load current applications and less dynamic (quickly changing) load conditions. For higher output current applications or dynamic load conditions a 68µF to 100µF low ESR capacitor is recommended. It is also recommended to put a small ceramic capacitor (0.1µF to 4.7µF) between the input pins and ground to reduce high frequency spikes.

INDUCTOR SELECTION

The most critical parameters for the inductor are the inductance, peak current and the DC resistance. The inductance is related to the peak-to-peak inductor ripple current, the input and the output voltages (for 300kHz operation):

$$L = \frac{(V_{IN} - V_{OUT})V_{OUT}}{V_{IN} \times I_{RIPPLE} \times 300 \text{ kHz}} \quad (4)$$

A higher value of ripple current reduces inductance, but increases the conductance loss, core loss, and current stress for the inductor and switch devices. It also requires a bigger output capacitor for the same output voltage ripple requirement. A reasonable value is setting the ripple current to be 30% of the DC output current. Since the ripple current increases with the input voltage, the maximum input voltage is always used to determine the inductance. The DC resistance of the inductor is a key parameter for the efficiency. Lower DC resistance is available with a bigger winding area. A good tradeoff between the efficiency and the core size is letting the inductor copper loss equal 2% of the output power.

OUTPUT CAPACITOR

The selection of C_{OUT} is driven by the maximum allowable output voltage ripple. The output ripple in the constant frequency, PWM mode is approximated by:

$$V_{RIPPLE} = I_{RIPPLE} \left(ESR + \frac{1}{8F_S C_{OUT}} \right) \quad (5)$$

The ESR term usually plays the dominant role in determining the voltage ripple. Low ESR ceramic, aluminum electrolytic, or tantalum capacitors (such as Taiyo Yuden MLCC, Nichicon PL series, Sanyo OS-CON, Sprague 593D, 594D, AVX TPS, and CDE polymer aluminum) is recommended. An electrolytic capacitor is not recommended for temperatures below -25°C since its ESR rises dramatically at cold temperature. Ceramic or tantalum capacitors have much better ESR specifications at cold temperature and is preferred for low temperature applications.

BOOTSTRAP CAPACITOR

A 4.7nF ceramic capacitor or larger is recommended for the bootstrap capacitor. For applications where the input voltage is less than twice the output voltage a larger capacitor is recommended, generally 0.1 μF to 1 μF to ensure plenty of gate drive for the internal switches and a consistently low $R_{DS(ON)}$.

SOFT-START CAPACITOR (BOTH REGULATORS)

The LM2717 does not contain internal soft-start which allows for fast startup time but also causes high inrush current. Therefore for applications that need reduced inrush current the LM2717 has circuitry that is used to limit the inrush current on start-up of the DC/DC switching regulators. This inrush current limiting circuitry serves as a soft-start. The external SS pins are used to tailor the soft-start for a specific application. A current (I_{SS}) charges the external soft-start capacitor, C_{SS} . The soft-start time can be estimated as:

$$T_{SS} = C_{SS} \cdot 0.6V / I_{SS} \quad (6)$$

When programming the softstart time simply use the equation given in the *Soft-Start Capacitor* section above.

SHUTDOWN OPERATION (BOTH REGULATORS)

The shutdown pins of the LM2717 are designed so that they may be controlled using 1.8V or higher logic signals. If the shutdown function is not to be used the pin may be left open. The maximum voltage to the shutdown pin should not exceed 7.5V. If the use of a higher voltage is desired due to system or other constraints it may be used, however a 100k or larger resistor is recommended between the applied voltage and the shutdown pin to protect the device.

SCHOTTKY DIODE

The breakdown voltage rating of D_1 and D_2 is preferred to be 25% higher than the maximum input voltage. The current rating for the diode should be equal to the maximum output current for best reliability in most applications. In cases where the input voltage is much greater than the output voltage the average diode current is lower. In this case it is possible to use a diode with a lower average current rating, approximately $(1-D) \cdot I_{OUT}$ however the peak current rating should be higher than the maximum load current.

LAYOUT CONSIDERATIONS

The LM2717 uses two separate ground connections, PGND for the drivers and boost NMOS power device and AGND for the sensitive analog control circuitry. The AGND and PGND pins should be tied directly together at the package. The feedback and compensation networks should be connected directly to a dedicated analog ground plane and this ground plane must connect to the AGND pin. If no analog ground plane is available then the ground connections of the feedback and compensation networks must tie directly to the AGND pin. Connecting these networks to the PGND can inject noise into the system and effect performance.

The input bypass capacitor C_{IN} , as shown in [Figure 12](#), must be placed close to the IC. This will reduce copper trace resistance which effects input voltage ripple of the IC. For additional input voltage filtering, a $0.1\mu\text{F}$ to $4.7\mu\text{F}$ bypass capacitors can be placed in parallel with C_{IN} , close to the V_{IN} pins to shunt any high frequency noise to ground. The output capacitors, C_{OUT1} and C_{OUT2} , should also be placed close to the IC. Any copper trace connections for the C_{OUTX} capacitors can increase the series resistance, which directly effects output voltage ripple. The feedback network, resistors R_{FB1} and R_{FB2} , should be kept close to the FB pin, and away from the inductor to minimize copper trace connections that can inject noise into the system. Trace connections made to the inductors and schottky diodes should be minimized to reduce power dissipation and increase overall efficiency. For more detail on switching power supply layout considerations see Application Note AN-1149: *Layout Guidelines for Switching Power Supplies*.

Application Information

Table 1. Some Recommended Inductors (Others May Be Used)

Manufacturer	Inductor	Contact Information
Coilcraft	DO3316 and DO5022 series	www.coilcraft.com
Coiltronics	DRQ73 and CD1 series	www.cooperet.com
Pulse	P0751 and P0762 series	www.pulseeng.com
Sumida	CDRH8D28 and CDRH8D43 series	www.sumida.com

Table 2. Some Recommended Input And Output Capacitors (Others May Be Used)

Manufacturer	Capacitor	Contact Information
Vishay Sprague	293D, 592D, and 595D series tantalum	www.vishay.com
Taiyo Yuden	High capacitance MLCC ceramic	www.t-yuden.com
Cornell Dubilier	ESRD seriec Polymer Aluminum Electrolytic SPV and AFK series V-chip series	www.cde.com
Panasonic	High capacitance MLCC ceramic EEJ-L series tantalum	www.panasonic.com

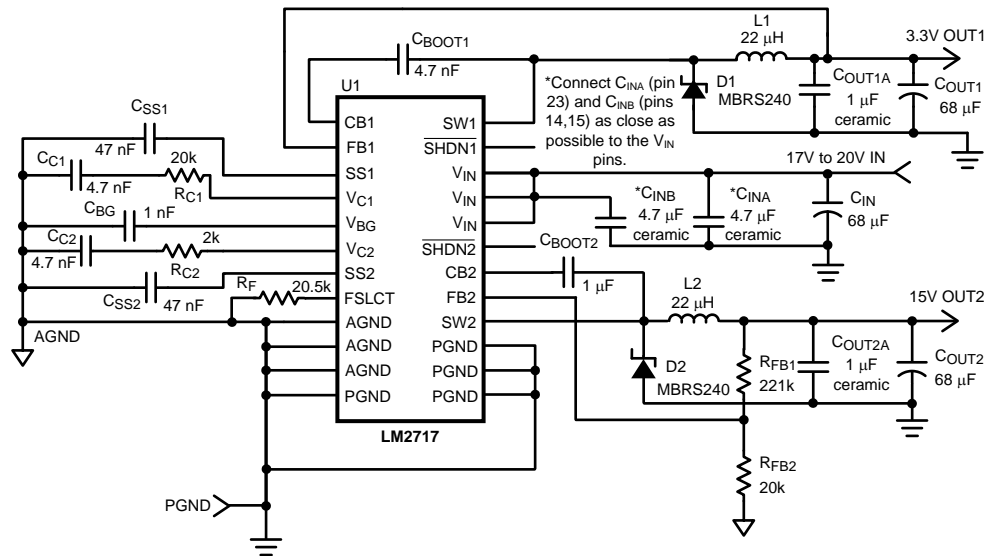

Figure 12. 15V, 3.3V Output Application

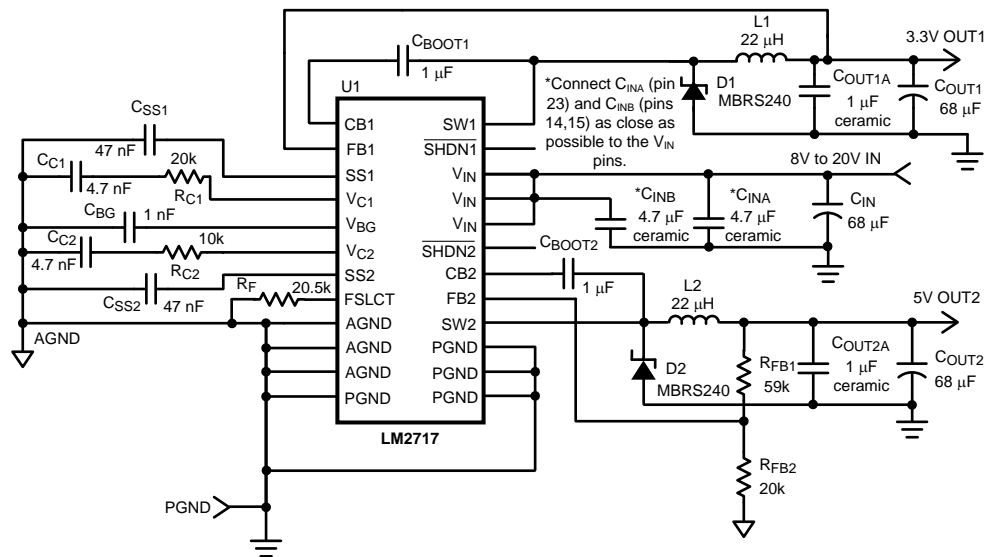

Figure 13. 5V, 3.3V Output Application

PACKAGING INFORMATION

Orderable Device	Status (1)	Package Type	Package Drawing	Pins	Package Qty	Eco Plan (2)	Lead/Ball Finish	MSL Peak Temp (3)	Op Temp (°C)	Top-Side Markings (4)	Samples
LM2717MT	ACTIVE	TSSOP	PW	24	61	TBD	Call TI	Call TI	-40 to 125	LM2717MT	Samples
LM2717MT/NOPB	ACTIVE	TSSOP	PW	24	61	Green (RoHS & no Sb/Br)	CU SN	Level-1-260C-UNLIM	-40 to 125	LM2717MT	Samples
LM2717MTX	ACTIVE	TSSOP	PW	24	2500	TBD	Call TI	Call TI	-40 to 125	LM2717MT	Samples
LM2717MTX/NOPB	ACTIVE	TSSOP	PW	24	2500	Green (RoHS & no Sb/Br)	CU SN	Level-1-260C-UNLIM	-40 to 125	LM2717MT	Samples

(1) The marketing status values are defined as follows:

ACTIVE: Product device recommended for new designs.

LIFEBUY: TI has announced that the device will be discontinued, and a lifetime-buy period is in effect.

NRND: Not recommended for new designs. Device is in production to support existing customers, but TI does not recommend using this part in a new design.

PREVIEW: Device has been announced but is not in production. Samples may or may not be available.

OBSOLETE: TI has discontinued the production of the device.

(2) Eco Plan - The planned eco-friendly classification: Pb-Free (RoHS), Pb-Free (RoHS Exempt), or Green (RoHS & no Sb/Br) - please check <http://www.ti.com/productcontent> for the latest availability information and additional product content details.

TBD: The Pb-Free/Green conversion plan has not been defined.

Pb-Free (RoHS): TI's terms "Lead-Free" or "Pb-Free" mean semiconductor products that are compatible with the current RoHS requirements for all 6 substances, including the requirement that lead not exceed 0.1% by weight in homogeneous materials. Where designed to be soldered at high temperatures, TI Pb-Free products are suitable for use in specified lead-free processes.

Pb-Free (RoHS Exempt): This component has a RoHS exemption for either 1) lead-based flip-chip solder bumps used between the die and package, or 2) lead-based die adhesive used between the die and leadframe. The component is otherwise considered Pb-Free (RoHS compatible) as defined above.

Green (RoHS & no Sb/Br): TI defines "Green" to mean Pb-Free (RoHS compatible), and free of Bromine (Br) and Antimony (Sb) based flame retardants (Br or Sb do not exceed 0.1% by weight in homogeneous material)

(3) MSL, Peak Temp. -- The Moisture Sensitivity Level rating according to the JEDEC industry standard classifications, and peak solder temperature.

(4) Only one of markings shown within the brackets will appear on the physical device.

Important Information and Disclaimer: The information provided on this page represents TI's knowledge and belief as of the date that it is provided. TI bases its knowledge and belief on information provided by third parties, and makes no representation or warranty as to the accuracy of such information. Efforts are underway to better integrate information from third parties. TI has taken and continues to take reasonable steps to provide representative and accurate information but may not have conducted destructive testing or chemical analysis on incoming materials and chemicals. TI and TI suppliers consider certain information to be proprietary, and thus CAS numbers and other limited information may not be available for release.

In no event shall TI's liability arising out of such information exceed the total purchase price of the TI part(s) at issue in this document sold by TI to Customer on an annual basis.

TAPE AND REEL INFORMATION



QUADRANT ASSIGNMENTS FOR PIN 1 ORIENTATION IN TAPE



*All dimensions are nominal

Device	Package Type	Package Drawing	Pins	SPQ	Reel Diameter (mm)	Reel Width W1 (mm)	A0 (mm)	B0 (mm)	K0 (mm)	P1 (mm)	W (mm)	Pin1 Quadrant
LM2717MTX	TSSOP	PW	24	2500	330.0	16.4	6.95	8.3	1.6	8.0	16.0	Q1
LM2717MTX/NOPB	TSSOP	PW	24	2500	330.0	16.4	6.95	8.3	1.6	8.0	16.0	Q1

TAPE AND REEL BOX DIMENSIONS

*All dimensions are nominal



Device	Package Type	Package Drawing	Pins	SPQ	Length (mm)	Width (mm)	Height (mm)
LM2717MTX	TSSOP	PW	24	2500	349.0	337.0	45.0
LM2717MTX/NOPB	TSSOP	PW	24	2500	349.0	337.0	45.0

PW (R-PDSO-G24)

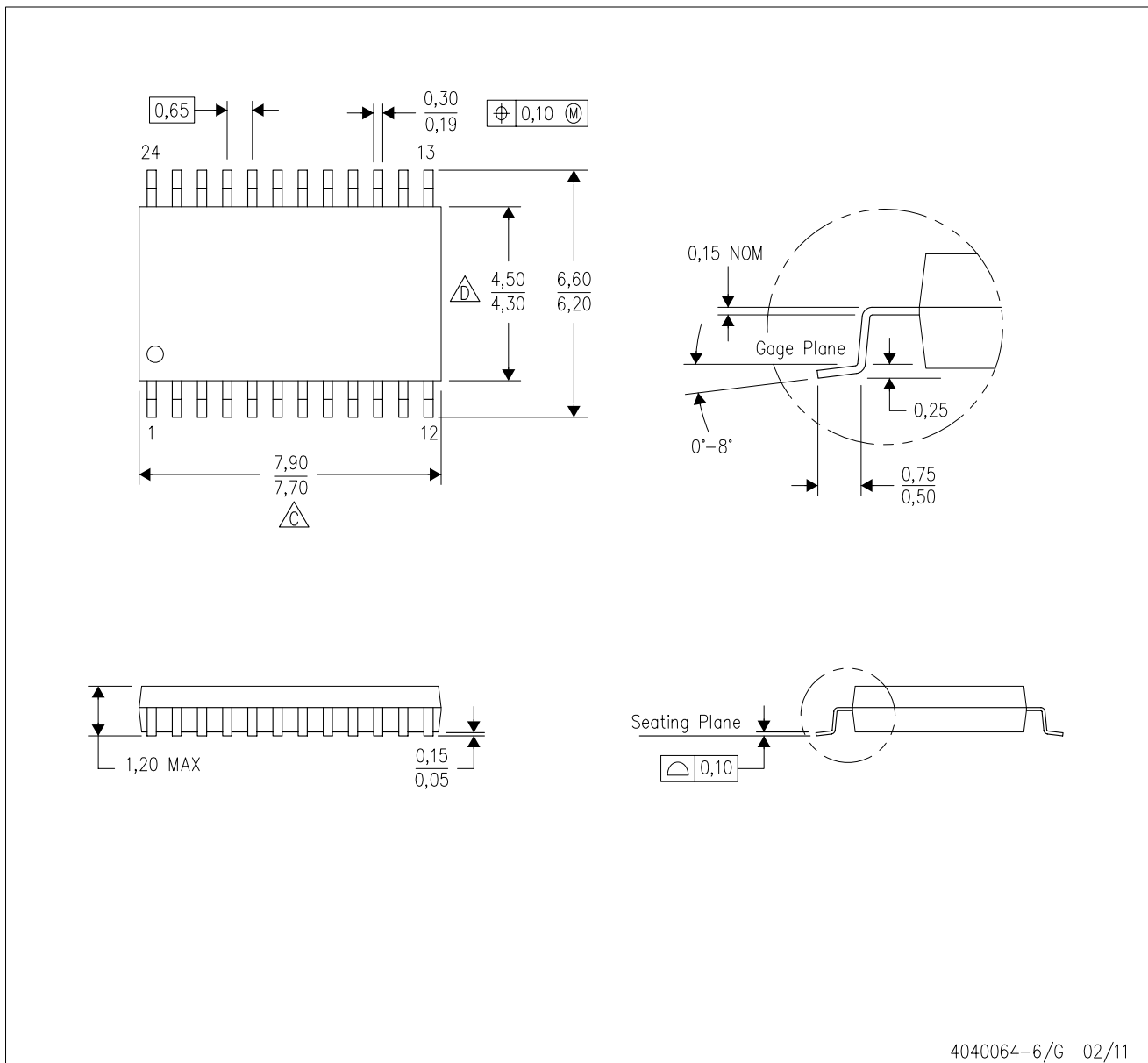
PLASTIC SMALL OUTLINE



4040064-6/G 02/11

- NOTES:
- A. All linear dimensions are in millimeters. Dimensioning and tolerancing per ASME Y14.5M-1994.
 - B. This drawing is subject to change without notice.
 -  Body length does not include mold flash, protrusions, or gate burrs. Mold flash, protrusions, or gate burrs shall not exceed 0,15 each side.
 -  Body width does not include interlead flash. Interlead flash shall not exceed 0,25 each side.
 - E. Falls within JEDEC MO-153

IMPORTANT NOTICE

Texas Instruments Incorporated and its subsidiaries (TI) reserve the right to make corrections, enhancements, improvements and other changes to its semiconductor products and services per JESD46, latest issue, and to discontinue any product or service per JESD48, latest issue. Buyers should obtain the latest relevant information before placing orders and should verify that such information is current and complete. All semiconductor products (also referred to herein as "components") are sold subject to TI's terms and conditions of sale supplied at the time of order acknowledgment.

TI warrants performance of its components to the specifications applicable at the time of sale, in accordance with the warranty in TI's terms and conditions of sale of semiconductor products. Testing and other quality control techniques are used to the extent TI deems necessary to support this warranty. Except where mandated by applicable law, testing of all parameters of each component is not necessarily performed.

TI assumes no liability for applications assistance or the design of Buyers' products. Buyers are responsible for their products and applications using TI components. To minimize the risks associated with Buyers' products and applications, Buyers should provide adequate design and operating safeguards.

TI does not warrant or represent that any license, either express or implied, is granted under any patent right, copyright, mask work right, or other intellectual property right relating to any combination, machine, or process in which TI components or services are used. Information published by TI regarding third-party products or services does not constitute a license to use such products or services or a warranty or endorsement thereof. Use of such information may require a license from a third party under the patents or other intellectual property of the third party, or a license from TI under the patents or other intellectual property of TI.

Reproduction of significant portions of TI information in TI data books or data sheets is permissible only if reproduction is without alteration and is accompanied by all associated warranties, conditions, limitations, and notices. TI is not responsible or liable for such altered documentation. Information of third parties may be subject to additional restrictions.

Resale of TI components or services with statements different from or beyond the parameters stated by TI for that component or service voids all express and any implied warranties for the associated TI component or service and is an unfair and deceptive business practice. TI is not responsible or liable for any such statements.

Buyer acknowledges and agrees that it is solely responsible for compliance with all legal, regulatory and safety-related requirements concerning its products, and any use of TI components in its applications, notwithstanding any applications-related information or support that may be provided by TI. Buyer represents and agrees that it has all the necessary expertise to create and implement safeguards which anticipate dangerous consequences of failures, monitor failures and their consequences, lessen the likelihood of failures that might cause harm and take appropriate remedial actions. Buyer will fully indemnify TI and its representatives against any damages arising out of the use of any TI components in safety-critical applications.

In some cases, TI components may be promoted specifically to facilitate safety-related applications. With such components, TI's goal is to help enable customers to design and create their own end-product solutions that meet applicable functional safety standards and requirements. Nonetheless, such components are subject to these terms.

No TI components are authorized for use in FDA Class III (or similar life-critical medical equipment) unless authorized officers of the parties have executed a special agreement specifically governing such use.

Only those TI components which TI has specifically designated as military grade or "enhanced plastic" are designed and intended for use in military/aerospace applications or environments. Buyer acknowledges and agrees that any military or aerospace use of TI components which have **not** been so designated is solely at the Buyer's risk, and that Buyer is solely responsible for compliance with all legal and regulatory requirements in connection with such use.

TI has specifically designated certain components as meeting ISO/TS16949 requirements, mainly for automotive use. In any case of use of non-designated products, TI will not be responsible for any failure to meet ISO/TS16949.

Products

Audio	www.ti.com/audio
Amplifiers	amplifier.ti.com
Data Converters	dataconverter.ti.com
DLP® Products	www.dlp.com
DSP	dsp.ti.com
Clocks and Timers	www.ti.com/clocks
Interface	interface.ti.com
Logic	logic.ti.com
Power Mgmt	power.ti.com
Microcontrollers	microcontroller.ti.com
RFID	www.ti-rfid.com
OMAP Applications Processors	www.ti.com/omap
Wireless Connectivity	www.ti.com/wirelessconnectivity

Applications

Automotive and Transportation	www.ti.com/automotive
Communications and Telecom	www.ti.com/communications
Computers and Peripherals	www.ti.com/computers
Consumer Electronics	www.ti.com/consumer-apps
Energy and Lighting	www.ti.com/energy
Industrial	www.ti.com/industrial
Medical	www.ti.com/medical
Security	www.ti.com/security
Space, Avionics and Defense	www.ti.com/space-avionics-defense
Video and Imaging	www.ti.com/video

TI E2E Community

e2e.ti.com