

LM2574

0.5 A, Adjustable Output Voltage, Step-Down Switching Regulator

The LM2574 series of regulators are monolithic integrated circuits ideally suited for easy and convenient design of a step-down switching regulator (buck converter). All circuits of this series are capable of driving a 0.5 A load with excellent line and load regulation. These devices are available in fixed output voltages of 3.3 V, 5.0 V, 12 V, 15 V, and an adjustable output version.

These regulators were designed to minimize the number of external components to simplify the power supply design. Standard series of inductors optimized for use with the LM2574 are offered by several different inductor manufacturers.

Since the LM2574 converter is a switch-mode power supply, its efficiency is significantly higher in comparison with popular three-terminal linear regulators, especially with higher input voltages. In most cases, the power dissipated by the LM2574 regulator is so low, that the copper traces on the printed circuit board are normally the only heatsink needed and no additional heatsinking is required.

The LM2574 features include a guaranteed $\pm 4\%$ tolerance on output voltage within specified input voltages and output load conditions, and $\pm 10\%$ on the oscillator frequency ($\pm 2\%$ over 0°C to $+125^\circ\text{C}$). External shutdown is included, featuring $60\ \mu\text{A}$ (typical) standby current. The output switch includes cycle-by-cycle current limiting, as well as thermal shutdown for full protection under fault conditions.

Features

- 3.3 V, 5.0 V, 12 V, 15 V, and Adjustable Output Versions
- Adjustable Version Output Voltage Range, 1.23 to 37 V $\pm 4\%$ max over Line and Load Conditions
- Guaranteed 0.5 A Output Current
- Wide Input Voltage Range: 4.75 to 40 V
- Requires Only 4 External Components
- 52 kHz Fixed Frequency Internal Oscillator
- TTL Shutdown Capability, Low Power Standby Mode
- High Efficiency
- Uses Readily Available Standard Inductors
- Thermal Shutdown and Current Limit Protection

Applications

- Simple and High-Efficiency Step-Down (Buck) Regulators
- Efficient Pre-regulator for Linear Regulators
- On-Card Switching Regulators
- Positive to Negative Converters (Buck-Boost)
- Negative Step-Up Converters
- Power Supply for Battery Chargers



ON Semiconductor™

<http://onsemi.com>

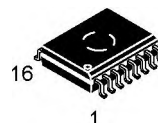

SO-16W
DW SUFFIX
CASE 751G

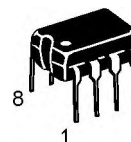

PDIP-8
N SUFFIX
CASE 626

PIN CONNECTIONS

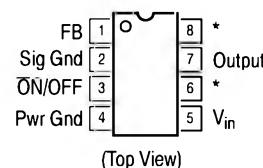
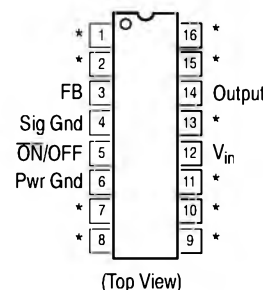

* No internal connection, but should be soldered to PC board for best heat transfer.

ORDERING INFORMATION

See detailed ordering and shipping information in the package dimensions section on page 1301 of this data sheet.

DEVICE MARKING INFORMATION

See general marking information in the device marking section on page 1301 of this data sheet.

LM2574

Typical Application (Fixed Output Voltage Versions)

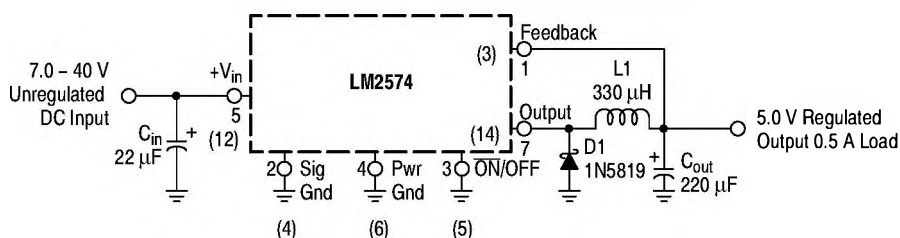

Representative Block Diagram and Typical Application

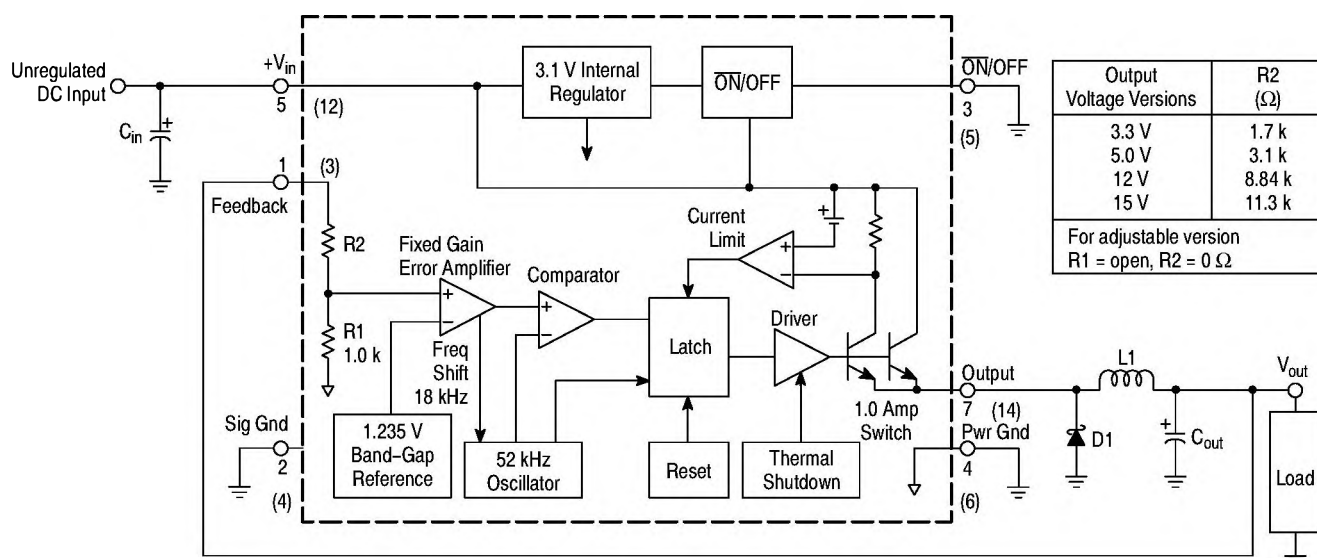

NOTE: Pin numbers in () are for the SO-16W package.

Figure 1. Block Diagram and Typical Application

ABSOLUTE MAXIMUM RATINGS (Absolute Maximum Ratings indicate limits beyond which damage to the device may occur).

Rating	Symbol	Value	Unit
Maximum Supply Voltage	V_{in}	45	V
ON/OFF Pin Input Voltage	-	$-0.3 \text{ V} \leq V \leq +V_{in}$	V
Output Voltage to Ground (Steady State)	-	-1.0	V
DW Suffix, Plastic Package Case 751 G Max Power Dissipation Thermal Resistance, Junction-to-Air	P_D $R_{\theta JA}$	Internally Limited 145	W °C/W
N Suffix, Plastic Package Case 626 Max Power Dissipation Thermal Resistance, Junction-to-Ambient Thermal Resistance, Junction-to-Case	P_D $R_{\theta JA}$ $R_{\theta JC}$	Internally Limited 100 5.0	W °C/W °C/W
Storage Temperature Range	T_{stg}	-65°C to +150°C	°C
Minimum ESD Rating (Human Body Model: C = 100 pF, R = 1.5 kΩ)	-	2.0	kV
Lead Temperature (Soldering, 10 seconds)	-	260	°C
Maximum Junction Temperature	T_J	150	°C

NOTE: ESD data available upon request.

LM2574

OPERATING RATINGS (Operating Ratings indicate conditions for which the device is intended to be functional, but do not guarantee specific performance limits. For guaranteed specifications and test conditions, see the Electrical Characteristics).

Rating	Symbol	Value	Unit
Operating Junction Temperature Range	T_J	-40 to +125	°C
Supply Voltage	V_{in}	40	V

SYSTEM PARAMETERS ([Note 1] Test Circuit Figure 16)

ELECTRICAL CHARACTERISTICS (Unless otherwise specified, $V_{in} = 12$ V for the 3.3 V, 5.0 V, and Adjustable version, $V_{in} = 25$ V for the 12 V version, $V_{in} = 30$ V for the 15 V version. $I_{Load} = 100$ mA. For typical values $T_J = 25^\circ\text{C}$, for min/max values T_J is the operating junction temperature range that applies [Note 2], unless otherwise noted).

Characteristic	Symbol	Min	Typ	Max	Unit
----------------	--------	-----	-----	-----	------

LM2574-3.3 ([Note 1] Test Circuit Figure 16)

Output Voltage ($V_{in} = 12$ V, $I_{Load} = 100$ mA, $T_J = 25^\circ\text{C}$)	V_{out}	3.234	3.3	3.366	V
Output Voltage (4.75 V $\leq V_{in} \leq 40$ V, 0.1 A $\leq I_{Load} \leq 0.5$ A) $T_J = 25^\circ\text{C}$ $T_J = -40$ to $+125^\circ\text{C}$	V_{out}	3.168 3.135	3.3 -	3.432 3.465	V
Efficiency ($V_{in} = 12$ V, $I_{Load} = 0.5$ A)	η	-	72	-	%

LM2574-5 ([Note 1] Test Circuit Figure 16)

Output Voltage ($V_{in} = 12$ V, $I_{Load} = 100$ mA, $T_J = 25^\circ\text{C}$)	V_{out}	4.9	5.0	5.1	V
Output Voltage (7.0 V $\leq V_{in} \leq 40$ V, 0.1 A $\leq I_{Load} \leq 0.5$ A) $T_J = 25^\circ\text{C}$ $T_J = -40$ to $+125^\circ\text{C}$	V_{out}	4.8 4.75	5.0	5.2 5.25	V
Efficiency ($V_{in} = 12$ V, $I_{Load} = 0.5$ A)	η	-	77	-	%

LM2574-12 ([Note 1] Test Circuit Figure 16)

Output Voltage ($V_{in} = 25$ V, $I_{Load} = 100$ mA, $T_J = 25^\circ\text{C}$)	V_{out}	11.76	10	12.24	V
Output Voltage (15 V $\leq V_{in} \leq 40$ V, 0.1 A $\leq I_{Load} \leq 0.5$ A) $T_J = 25^\circ\text{C}$ $T_J = -40$ to $+125^\circ\text{C}$	V_{out}	11.52 11.4	12 -	12.48 12.6	V
Efficiency ($V_{in} = 15$ V, $I_{Load} = 0.5$ A)	η	-	88	-	%

LM2574-15 ([Note 1] Test Circuit Figure 16)

Output Voltage ($V_{in} = 30$ V, $I_{Load} = 100$ mA, $T_J = 25^\circ\text{C}$)	V_{out}	14.7	15	15.3	V
Output Voltage (18 V $< V_{in} < 40$ V, 0.1 A $< I_{Load} < 0.5$ A) $T_J = 25^\circ\text{C}$ $T_J = -40$ to $+125^\circ\text{C}$	V_{out}	14.4 14.25	15	15.6 15.75	V
Efficiency ($V_{in} = 18$ V, $I_{Load} = 0.5$ A)	η	-	88	-	%

LM2574 ADJUSTABLE VERSION ([Note 1] Test Circuit Figure 16)

Feedback Voltage $V_{in} = 12$ V, $I_{Load} = 100$ mA, $V_{out} = 5.0$ V, $T_J = 25^\circ\text{C}$	V_{FB}	1.217	1.23	1.243	V
Feedback Voltage 7.0 V $\leq V_{in} \leq 40$ V, 0.1 A $\leq I_{Load} \leq 0.5$ A, $V_{out} = 5.0$ V $T_J = 25^\circ\text{C}$ $T_J = -40$ to $+125^\circ\text{C}$	V_{FBT}	1.193 1.18	1.23	1.267 1.28	V
Efficiency ($V_{in} = 12$ V, $I_{Load} = 0.5$ A, $V_{out} = 5.0$ V)	η	-	77	-	%

- External components such as the catch diode, inductor, input and output capacitors can affect the switching regulator system performance. When the LM2574 is used as shown in the Figure 16 test circuit, the system performance will be as shown in the system parameters section of the Electrical Characteristics.
- Tested junction temperature range for the LM2574: $T_{low} = -40^\circ\text{C}$ $T_{high} = +125^\circ\text{C}$.

LM2574

SYSTEM PARAMETERS ([Note 1] Test Circuit Figure 16)

ELECTRICAL CHARACTERISTICS (continued) (Unless otherwise specified, $V_{in} = 12\text{ V}$ for the 3.3 V, 5.0 V, and Adjustable version, $V_{in} = 25\text{ V}$ for the 12 V version, $V_{in} = 30\text{ V}$ for the 15 V version. $I_{Load} = 100\text{ mA}$. For typical values $T_J = 25^\circ\text{C}$, for min/max values T_J is the operating junction temperature range that applies [Note 2], unless otherwise noted).

Characteristic	Symbol	Min	Typ	Max	Unit
ALL OUTPUT VOLTAGE VERSIONS					
Feedback Bias Current $V_{out} = 5.0\text{ V}$ (Adjustable Version Only) $T_J = 25^\circ\text{C}$ $T_J = -40\text{ to }+125^\circ\text{C}$	I_b	– –	25 –	100 200	nA
Oscillator Frequency (Note 3) $T_J = 25^\circ\text{C}$ $T_J = 0\text{ to }+125^\circ\text{C}$ $T_J = -40\text{ to }+125^\circ\text{C}$	f_O	– 47 42	52 52 –	– 58 63	kHz
Saturation Voltage ($I_{out} = 0.5\text{ A}$, [Note 4]) $T_J = 25^\circ\text{C}$ $T_J = -40\text{ to }+125^\circ\text{C}$	V_{sat}	– –	1.0 –	1.2 1.4	V
Max Duty Cycle ("on") (Note 5)	DC	93	98	–	%
Current Limit Peak Current (Notes 3 and 4) $T_J = 25^\circ\text{C}$ $T_J = -40\text{ to }+125^\circ\text{C}$	I_{CL}	0.7 0.65	1.0 –	1.6 1.8	A
Output Leakage Current (Notes 6 and 7), $T_J = 25^\circ\text{C}$ Output = 0 V Output = – 1.0 V	I_L	– –	0.6 10	2.0 30	mA
Quiescent Current (Note 6) $T_J = 25^\circ\text{C}$ $T_J = -40\text{ to }+125^\circ\text{C}$	I_Q	– –	5.0 –	9.0 11	mA
Standby Quiescent Current ($\overline{\text{ON}}/\text{OFF Pin} = 5.0\text{ V}$ ("off")) $T_J = 25^\circ\text{C}$ $T_J = -40\text{ to }+125^\circ\text{C}$	I_{stby}	– –	60 –	200 400	μA
$\overline{\text{ON}}/\text{OFF Pin}$ Logic Input Level $V_{out} = 0\text{ V}$ $T_J = 25^\circ\text{C}$ $T_J = -40\text{ to }+125^\circ\text{C}$ Nominal Output Voltage $T_J = 25^\circ\text{C}$ $T_J = -40\text{ to }+125^\circ\text{C}$	V_{IH} V_{IL}	2.2 2.4 – –	1.4 – 1.2 –	– – 1.0 0.8	V
$\overline{\text{ON}}/\text{OFF Pin}$ Input Current $\overline{\text{ON}}/\text{OFF Pin} = 5.0\text{ V}$ ("off"), $T_J = 25^\circ\text{C}$ $\overline{\text{ON}}/\text{OFF Pin} = 0\text{ V}$ ("on"), $T_J = 25^\circ\text{C}$	I_{IH} I_{IL}	– –	15 0	30 5.0	μA

- External components such as the catch diode, inductor, input and output capacitors can affect the switching regulator system performance. When the LM2574 is used as shown in the Figure 16 test circuit, the system performance will be as shown in the system parameters section of the Electrical Characteristics.
- Tested junction temperature range for the LM2574: $T_{low} = -40^\circ\text{C}$ $T_{high} = +125^\circ\text{C}$.
- The oscillator frequency reduces to approximately 18 kHz in the event of an output short or an overload which causes the regulated output voltage to drop approximately 40% from the nominal output voltage. This self protection feature lowers the average power dissipation of the IC by lowering the minimum duty cycle from 5% down to approximately 2%.
- Output (Pin 2) sourcing current. No diode, inductor or capacitor connected to the output pin.
- Feedback (Pin 4) removed from output and connected to 0 V.
- Feedback (Pin 4) removed from output and connected to 12 V for the Adjustable, 3.3 V, and 5.0 V versions, and 25 V for the 12 V and 15 V versions, to force the output transistor OFF.
- $V_{in} = 40\text{ V}$.

TYPICAL PERFORMANCE CHARACTERISTICS (Circuit of Figure 16)

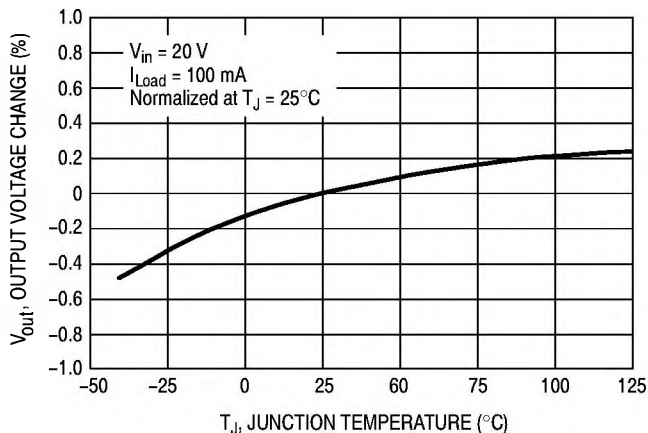

Figure 2. Normalized Output Voltage

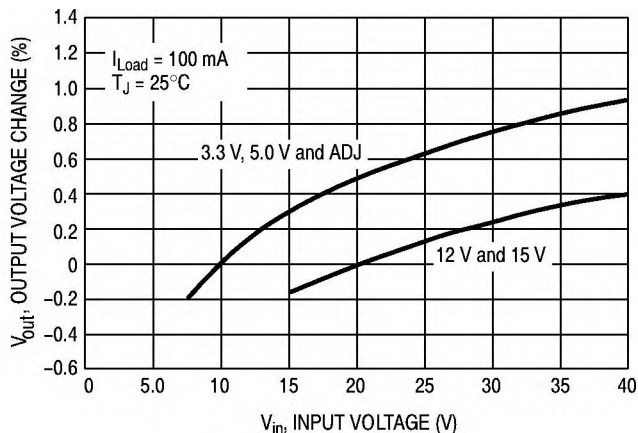

Figure 3. Line Regulation

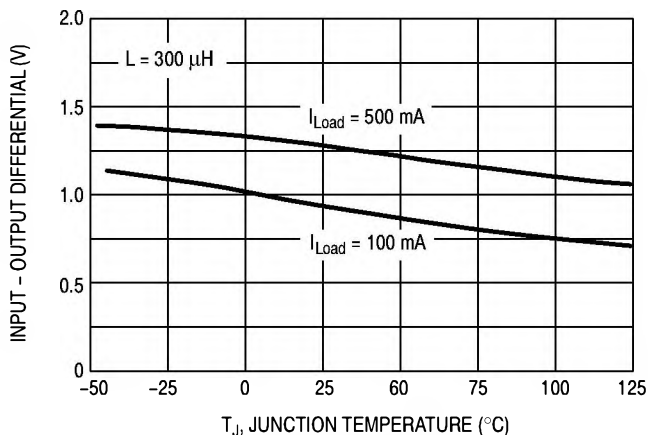

Figure 4. Dropout Voltage

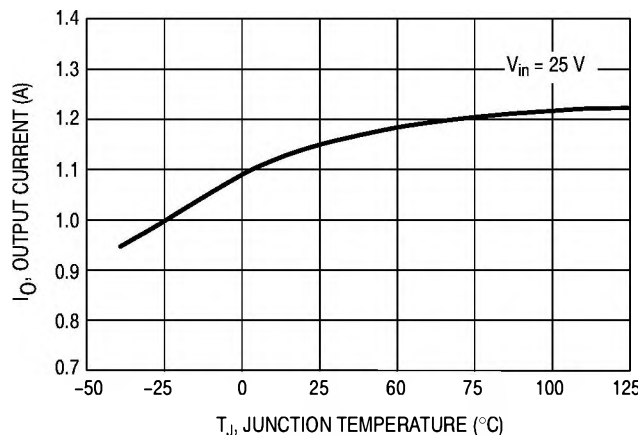

Figure 5. Current Limit

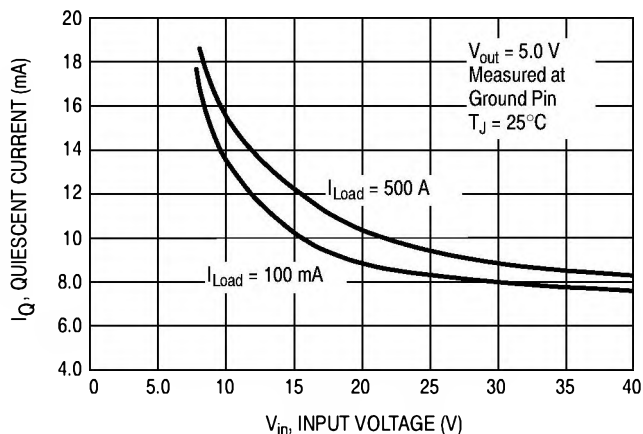

Figure 6. Quiescent Current

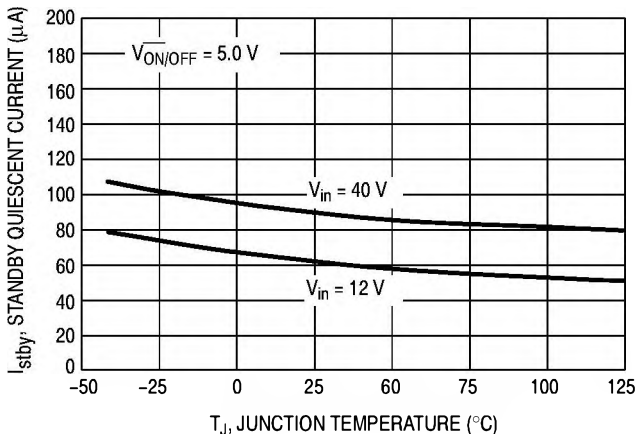

Figure 7. Standby Quiescent Current

TYPICAL PERFORMANCE CHARACTERISTICS (Circuit of Figure 16) (continued)

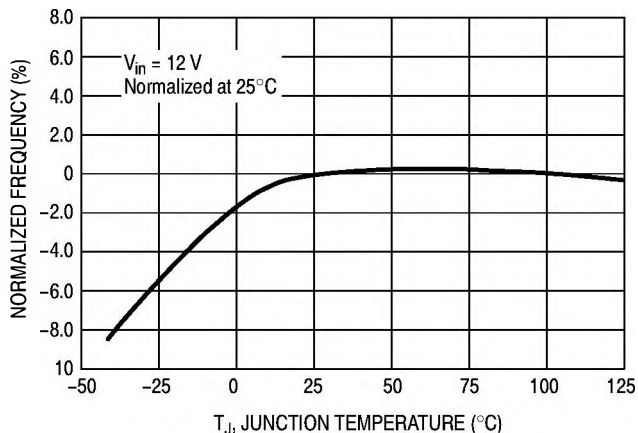

Figure 8. Oscillator Frequency

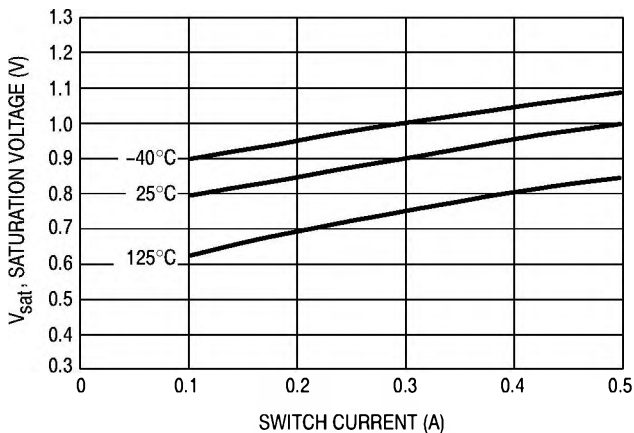

Figure 9. Switch Saturation Voltage

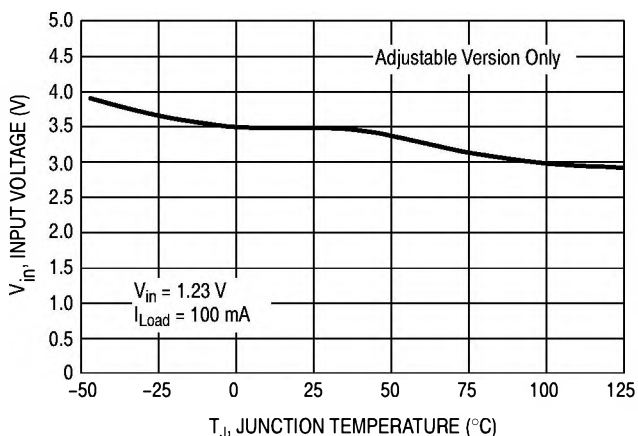

Figure 10. Minimum Operating Voltage

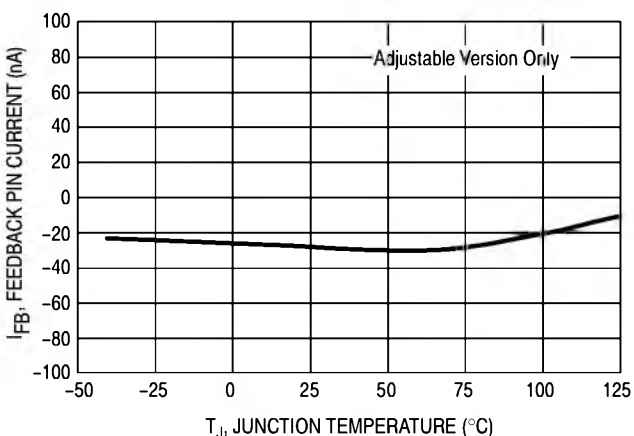
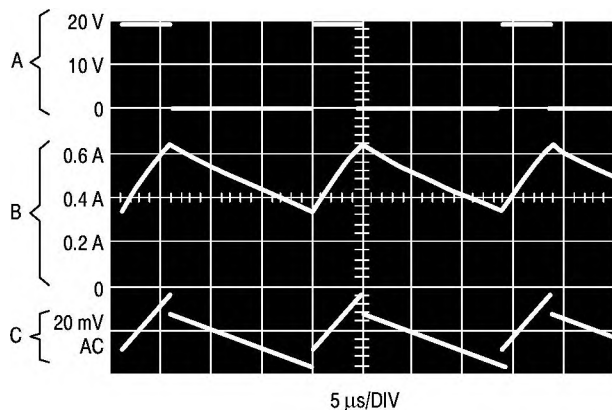
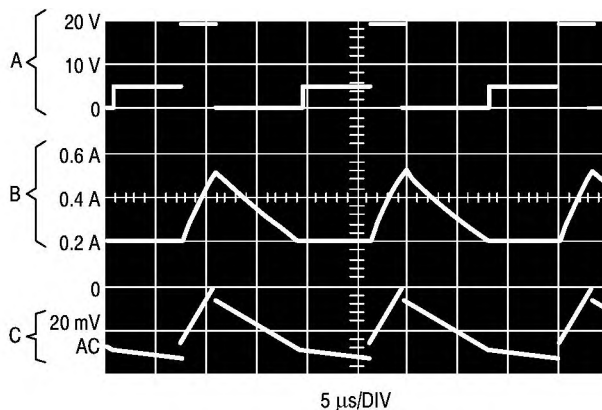

Figure 11. Feedback Pin Current



A: Output Pin Voltage, 10 V/DIV.
B: Inductor Current, 0.2 A/DIV.
C: Output Ripple Voltage, 20 mV/DIV, AC-Coupled

Figure 12. Continuous Mode Switching Waveforms
 $V_{out} = 5.0\text{ V}$, 500 mA Load Current, $L = 330\text{ }\mu\text{H}$



A: Output Pin Voltage, 10 V/DIV.
B: Inductor Current, 0.2 A/DIV.
C: Output Ripple Voltage, 20 mV/DIV, AC-Coupled

Figure 13. Discontinuous Mode Switching Waveforms
 $V_{out} = 5.0\text{ V}$, 100 mA Load Current, $L = 100\text{ }\mu\text{H}$

TYPICAL PERFORMANCE CHARACTERISTICS (Circuit of Figure 16) (continued)

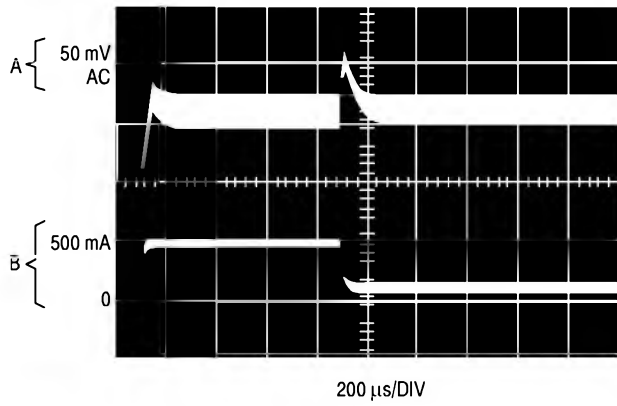

A: Output Voltage, 50 mV/DIV, AC Coupled
 B: 100 mA to 500 mA Load Pulse

Figure 14. 500 mA Load Transient Response for Continuous Mode Operation, $L = 330 \mu\text{H}$, $C_{\text{out}} = 300 \mu\text{F}$

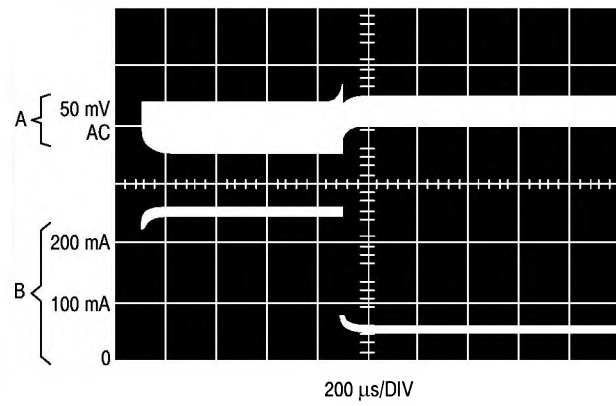

A: Output Voltage, 50 mV/DIV, AC Coupled
 B: 50 mA to 250 mA Load Pulse

Figure 15. 250 mA Load Transient Response for Discontinuous Mode Operation, $L = 68 \mu\text{H}$, $C_{\text{out}} = 470 \mu\text{F}$

LM2574

Fixed Output Voltage Versions

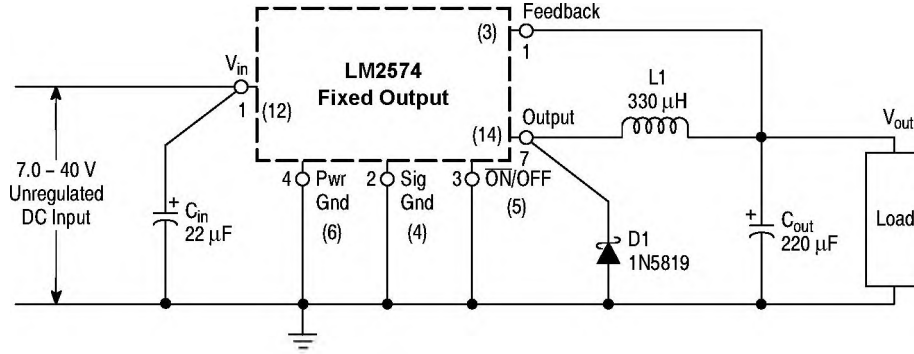

- C_{in} - 22 μ F, 60 V, Aluminium Electrolytic
- C_{out} - 220 μ F, 25 V, Aluminium Electrolytic
- D1 - Schottky, 1N5819
- L1 - 330 μ H, (For 5.0 V_{in} , 3.3 V_{out} , use 100 μ H)
- R1 - 2.0 k, 0.1%
- R2 - 6.12 k, 0.1%

Adjustable Output Voltage Versions

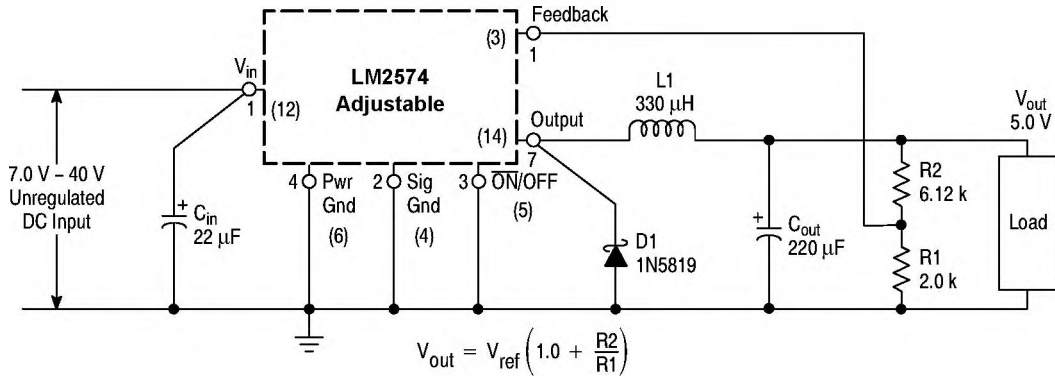

$$V_{out} = V_{ref} \left(1.0 + \frac{R2}{R1} \right)$$

$$R2 = R1 \left(\frac{V_{out}}{V_{ref}} - 1.0 \right)$$

Where $V_{ref} = 1.23$ V, $R1$ between 1.0 k Ω and 5.0 k Ω

NOTE: Pin numbers in () are for the SO-16W package.

Figure 16. Test Circuit and Layout Guidelines

PCB LAYOUT GUIDELINES

As in any switching regulator, the layout of the printed circuit board is very important. Rapidly switching currents associated with wiring inductance, stray capacitance and parasitic inductance of the printed circuit board traces can generate voltage transients which can generate electromagnetic interferences (EMI) and affect the desired operation. As indicated in the Figure 16, to minimize inductance and ground loops, the length of the leads indicated by heavy lines should be kept as short as possible.

For best results, single-point grounding (as indicated) or ground plane construction should be used.

On the other hand, the PCB area connected to the Pin 7 (emitter of the internal switch) of the LM2574 should be kept to a minimum in order to minimize coupling to sensitive circuitry.

Another sensitive part of the circuit is the feedback. It is important to keep the sensitive feedback wiring short. To assure this, physically locate the programming resistors near to the regulator, when using the adjustable version of the LM2574 regulator.

PIN FUNCTION DESCRIPTION

Pin		Symbol	Description (Refer to Figure 1)
SO-16W	PDIP-8		
12	5	V_{in}	This pin is the positive input supply for the LM2574 step-down switching regulator. In order to minimize voltage transients and to supply the switching currents needed by the regulator, a suitable input bypass capacitor must be present (C_{in} in Figure 1).
14	7	Output	This is the emitter of the internal switch. The saturation voltage V_{sat} of this output switch is typically 1.0 V. It should be kept in mind that the PCB area connected to this pin should be kept to a minimum in order to minimize coupling to sensitive circuitry.
4	2	Sig Gnd	Circuit signal ground pin. See the information about the printed circuit board layout.
6	4	Pwr Gnd	Circuit power ground pin. See the information about the printed circuit board layout.
3	1	Feedback	This pin senses regulated output voltage to complete the feedback loop. The signal is divided by the internal resistor divider network R2, R1 and applied to the non-inverting input of the internal error amplifier. In the Adjustable version of the LM2574 switching regulator, this pin is the direct input of the error amplifier and the resistor network R2, R1 is connected externally to allow programming of the output voltage.
5	3	$\overline{ON/OFF}$	It allows the switching regulator circuit to be shut down using logic level signals, thus dropping the total input supply current to approximately 80 μ A. The input threshold voltage is typically 1.5 V. Applying a voltage above this value (up to $+V_{in}$) shuts the regulator off. If the voltage applied to this pin is lower than 1.5 V or if this pin is left open, the regulator will be in the "on" condition.

DESIGN PROCEDURE

Buck Converter Basics

The LM2574 is a "Buck" or Step-Down Converter which is the most elementary forward-mode converter. Its basic schematic can be seen in Figure 17.

The operation of this regulator topology has two distinct time periods. The first one occurs when the series switch is on, the input voltage is connected to the input of the inductor.

The output of the inductor is the output voltage, and the rectifier (or catch diode) is reverse biased. During this period, since there is a constant voltage source connected across the inductor, the inductor current begins to linearly ramp upwards, as described by the following equation:

$$I_{L(on)} = \frac{(V_{in} - V_{out}) t_{on}}{L}$$

During this "on" period, energy is stored within the core material in the form of magnetic flux. If the inductor is properly designed, there is sufficient energy stored to carry the requirements of the load during the "off" period.

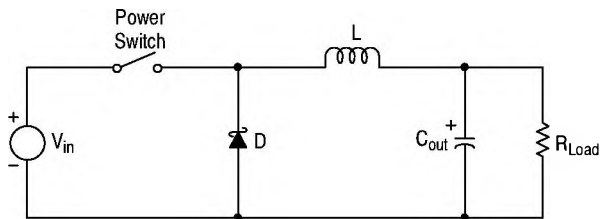

Figure 17. Basic Buck Converter

The next period is the "off" period of the power switch. When the power switch turns off, the voltage across the inductor reverses its polarity and is clamped at one diode voltage drop below ground by the catch diode. Current now flows through the catch diode thus maintaining the load

current loop. This removes the stored energy from the inductor. The inductor current during this time is:

$$I_{L(off)} = \frac{(V_{out} - V_D) t_{off}}{L}$$

This period ends when the power switch is once again turned on. Regulation of the converter is accomplished by varying the duty cycle of the power switch. It is possible to describe the duty cycle as follows:

$$d = \frac{t_{on}}{T}, \text{ where } T \text{ is the period of switching.}$$

For the buck converter with ideal components, the duty cycle can also be described as:

$$d = \frac{V_{out}}{V_{in}}$$

Figure 18 shows the buck converter idealized waveforms of the catch diode voltage and the inductor current.

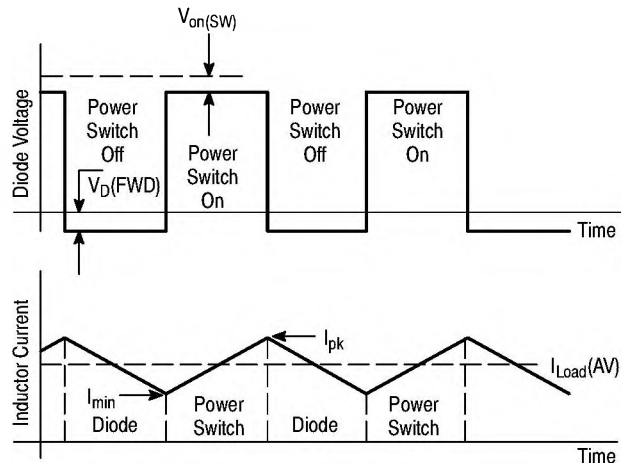

Figure 18. Buck Converter Idealized Waveforms

Procedure (Fixed Output Voltage Version) In order to simplify the switching regulator design, a step-by-step design procedure and example is provided.

Procedure	Example
<p>Given Parameters: V_{out} = Regulated Output Voltage (3.3 V, 5.0 V, 12 V or 15 V) $V_{in(max)}$ = Maximum Input Voltage $I_{Load(max)}$ = Maximum Load Current</p>	<p>Given Parameters: V_{out} = 5.0 V $V_{in(max)}$ = 15 V $I_{Load(max)}$ = 0.4 A</p>
<p>1. Controller IC Selection According to the required input voltage, output voltage and current, select the appropriate type of the controller IC output voltage version.</p>	<p>1. Controller IC Selection According to the required input voltage, output voltage, current polarity and current value, use the LM2574-5 controller IC.</p>
<p>2. Input Capacitor Selection (C_{in}) To prevent large voltage transients from appearing at the input and for stable operation of the converter, an aluminium or tantalum electrolytic bypass capacitor is needed between the input pin +V_{in} and ground pin Gnd. This capacitor should be located close to the IC using short leads. This capacitor should have a low ESR (Equivalent Series Resistance) value.</p>	<p>2. Input Capacitor Selection (C_{in}) A 22 μF, 25 V aluminium electrolytic capacitor located near to the input and ground pins provides sufficient bypassing.</p>
<p>3. Catch Diode Selection (D1) A. Since the diode maximum peak current exceeds the regulator maximum load current, the catch diode current rating must be at least 1.2 times greater than the maximum load current. For a robust design the diode should have a current rating equal to the maximum current limit of the LM2574 to be able to withstand a continuous output short. B. The reverse voltage rating of the diode should be at least 1.25 times the maximum input voltage.</p>	<p>3. Catch Diode Selection (D1) A. For this example the current rating of the diode is 1.0 A. B. Use a 20 V 1N5817 Schottky diode, or any of the suggested fast recovery diodes shown in Table 1.</p>
<p>4. Inductor Selection (L1) A. According to the required working conditions, select the correct inductor value using the selection guide from Figures 19 to 23. B. From the appropriate inductor selection guide, identify the inductance region intersected by the Maximum Input Voltage line and the Maximum Load Current line. Each region is identified by an inductance value and an inductor code. C. Select an appropriate inductor from the several different manufacturers part numbers listed in Table 2. The designer must realize that the inductor current rating must be higher than the maximum peak current flowing through the inductor. This maximum peak current can be calculated as follows:</p> $I_{p(max)} = I_{Load(max)} + \frac{(V_{in} - V_{out})t_{on}}{2L}$ <p>where t_{on} is the "on" time of the power switch and</p> $t_{on} = \frac{V_{out}}{V_{in}} \times \frac{1.0}{f_{osc}}$ <p>For additional information about the inductor, see the inductor section in the "EXTERNAL COMPONENTS" section of this data sheet.</p>	<p>4. Inductor Selection (L1) A. Use the inductor selection guide shown in Figure 20. B. From the selection guide, the inductance area intersected by the 15 V line and 0.4 A line is 330. C. Inductor value required is 330 μH. From Table 2, choose an inductor from any of the listed manufacturers.</p>

Procedure (Fixed Output Voltage Version) (continued) In order to simplify the switching regulator design, a step-by-step design procedure and example is provided.

Procedure	Example
<p>5. Output Capacitor Selection (C_{out})</p> <p>A. Since the LM2574 is a forward-mode switching regulator with voltage mode control, its open loop 2-pole-1-zero frequency characteristic has the dominant pole-pair determined by the output capacitor and inductor values. For stable operation and an acceptable ripple voltage, (approximately 1% of the output voltage) a value between 100 μF and 470 μF is recommended.</p> <p>B. Due to the fact that the higher voltage electrolytic capacitors generally have lower ESR (Equivalent Series Resistance) numbers, the output capacitor's voltage rating should be at least 1.5 times greater than the output voltage. For a 5.0 V regulator, a rating at least 8.0 V is appropriate, and a 10 V or 16 V rating is recommended.</p>	<p>5. Output Capacitor Selection (C_{out})</p> <p>A. C_{out} = 100 μF to 470 μF standard aluminium electrolytic.</p> <p>B. Capacitor voltage rating = 20 V.</p>

Procedure (Adjustable Output Version: LM2574-ADJ)

Procedure	Example
<p>Given Parameters:</p> <p>V_{out} = Regulated Output Voltage $V_{in(max)}$ = Maximum DC Input Voltage $I_{Load(max)}$ = Maximum Load Current</p>	<p>Given Parameters:</p> <p>V_{out} = 24 V $V_{in(max)}$ = 40 V $I_{Load(max)}$ = 0.4 A</p>
<p>1. Programming Output Voltage</p> <p>To select the right programming resistor R1 and R2 value (see Figure 2) use the following formula:</p> $V_{out} = V_{ref} \left(1.0 + \frac{R2}{R1} \right) \text{ where } V_{ref} = 1.23 \text{ V}$ <p>Resistor R1 can be between 1.0 kΩ and 5.0 kΩ. (For best temperature coefficient and stability with time, use 1% metal film resistors).</p> $R2 = R1 \left(\frac{V_{out}}{V_{ref}} - 1.0 \right)$	<p>1. Programming Output Voltage (selecting R1 and R2)</p> <p>Select R1 and R2 :</p> $V_{out} = 1.23 \left(1.0 + \frac{R2}{R1} \right) \text{ Select } R1 = 1.0 \text{ k}\Omega$ $R2 = R1 \left(\frac{V_{out}}{V_{ref}} - 1.0 \right) = 1.0 \text{ k} \left(\frac{10 \text{ V}}{1.23 \text{ V}} - 1.0 \right)$ <p>R2 = 18.51 kΩ, choose a 18.7 kΩ metal film resistor.</p>
<p>2. Input Capacitor Selection (C_{in})</p> <p>To prevent large voltage transients from appearing at the input and for stable operation of the converter, an aluminium or tantalum electrolytic bypass capacitor is needed between the input pin +V_{in} and ground pin Gnd. This capacitor should be located close to the IC using short leads. This capacitor should have a low ESR (Equivalent Series Resistance) value. For additional information see input capacitor section in the "EXTERNAL COMPONENTS" section of this data sheet.</p>	<p>2. Input Capacitor Selection (C_{in})</p> <p>A 22 μF aluminium electrolytic capacitor located near the input and ground pin provides sufficient bypassing.</p>
<p>3. Catch Diode Selection (D1)</p> <p>A. Since the diode maximum peak current exceeds the regulator maximum load current the catch diode current rating must be at least 1.2 times greater than the maximum load current. For a robust design, the diode should have a current rating equal to the maximum current limit of the LM2574 to be able to withstand a continuous output short.</p> <p>B. The reverse voltage rating of the diode should be at least 1.25 times the maximum input voltage.</p>	<p>3. Catch Diode Selection (D1)</p> <p>A. For this example, a 1.0 A current rating is adequate.</p> <p>B. Use a 50 V MBR150 Schottky diode or any suggested fast recovery diodes in Table 1.</p>

Procedure (Adjustable Output Version: LM2574–ADJ)

Procedure	Example
<p>4. Inductor Selection (L1)</p> <p>A. Use the following formula to calculate the inductor Volt x microsecond [V x μs] constant:</p> $E \times T = (V_{in} - V_{out}) \frac{V_{out}}{V_{in}} \times \frac{10^6}{F[\text{Hz}]} \text{ [V x } \mu\text{s]}$ <p>B. Match the calculated E x T value with the corresponding number on the vertical axis of the Inductor Value Selection Guide shown in Figure 23. This E x T constant is a measure of the energy handling capability of an inductor and is dependent upon the type of core, the core area, the number of turns, and the duty cycle.</p> <p>C. Next step is to identify the inductance region intersected by the E x T value and the maximum load current value on the horizontal axis shown in Figure 27.</p> <p>D. From the inductor code, identify the inductor value. Then select an appropriate inductor from Table 2. The inductor chosen must be rated for a switching frequency of 52 kHz and for a current rating of $1.15 \times I_{Load}$. The inductor current rating can also be determined by calculating the inductor peak current:</p> $I_{p(\max)} = I_{Load(\max)} + \frac{(V_{in} - V_{out})t_{on}}{2L}$ <p>where t_{on} is the "on" time of the power switch and</p> $t_{on} = \frac{V_{out}}{V_{in}} \times \frac{1.0}{f_{osc}}$ <p>For additional information about the inductor, see the inductor section in the "External Components" section of this data sheet.</p>	<p>4. Inductor Selection (L1)</p> <p>A. Calculate E x T [V x μs] constant :</p> $E \times T = (40 - 24) \times \frac{24}{40} \times \frac{1000}{52} = 105 \text{ [V x } \mu\text{s]}$ <p>B. E x T = 185 [V x μs]</p> <p>C. $I_{Load(\max)} = 0.4 \text{ A}$ Inductance Region = 1000</p> <p>D. Proper inductor value = 1000 μH Choose the inductor from Table 2.</p>
<p>5. Output Capacitor Selection (C_{out})</p> <p>A. Since the LM2574 is a forward-mode switching regulator with voltage mode control, its open loop 2-pole-1-zero frequency characteristic has the dominant pole-pair determined by the output capacitor and inductor values.</p> <p>For stable operation, the capacitor must satisfy the following requirement:</p> $C_{out} \geq 13,300 \frac{V_{in(\max)}}{V_{out} \times L[\mu\text{H}]} \text{ [\mu F]}$ <p>B. Capacitor values between 10 μF and 2000 μF will satisfy the loop requirements for stable operation. To achieve an acceptable output ripple voltage and transient response, the output capacitor may need to be several times larger than the above formula yields.</p> <p>C. Due to the fact that the higher voltage electrolytic capacitors generally have lower ESR (Equivalent Series Resistance) numbers, the output capacitor's voltage rating should be at least 1.5 times greater than the output voltage. For a 5.0 V regulator, a rating of at least 8.0 V is appropriate, and a 10 V or 16V rating is recommended.</p>	<p>5. Output Capacitor Selection (C_{out})</p> <p>A.</p> $C_{out} \geq 13,300 \times \frac{40}{24 \times 1000} = 22.2 \text{ } \mu\text{F}$ <p>To achieve an acceptable ripple voltage, select $C_{out} = 100 \text{ } \mu\text{F}$ electrolytic capacitor.</p>

LM2574

LM2574 Series Buck Regulator Design Procedures (continued)

Indicator Value Selection Guide (For Continuous Mode Operation)

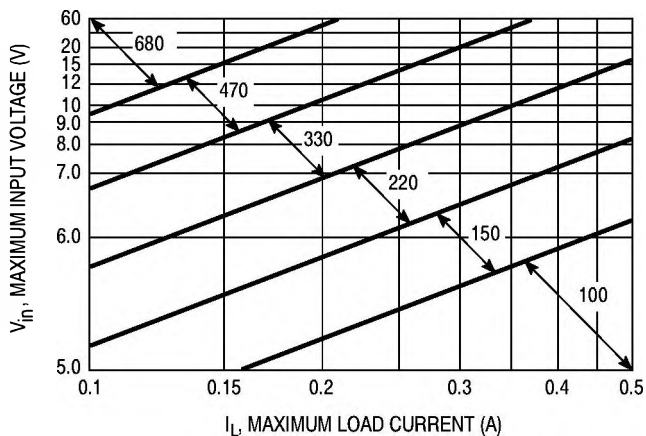

Figure 19. LM2574-3.3

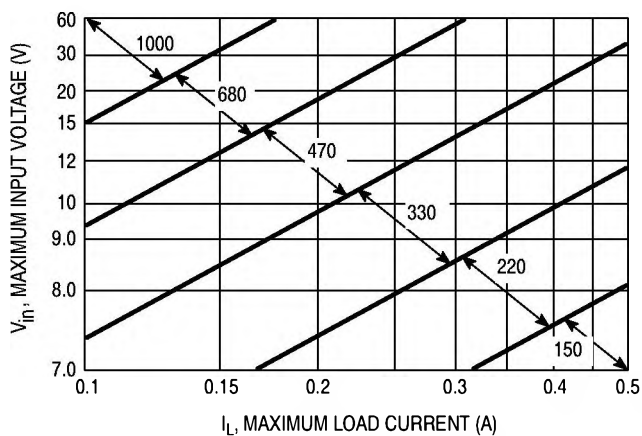

Figure 20. LM2574-5

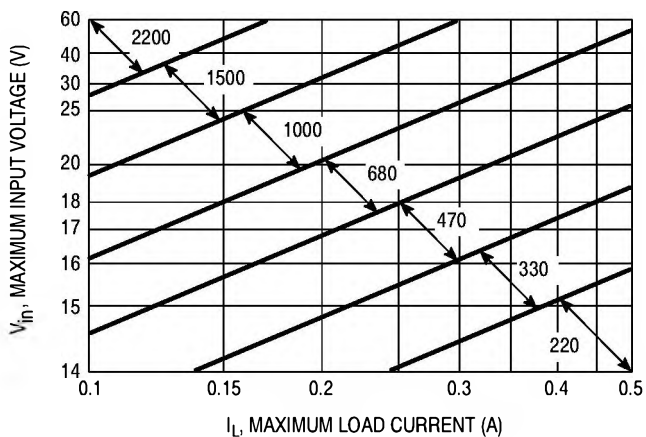

Figure 21. LM2574-12

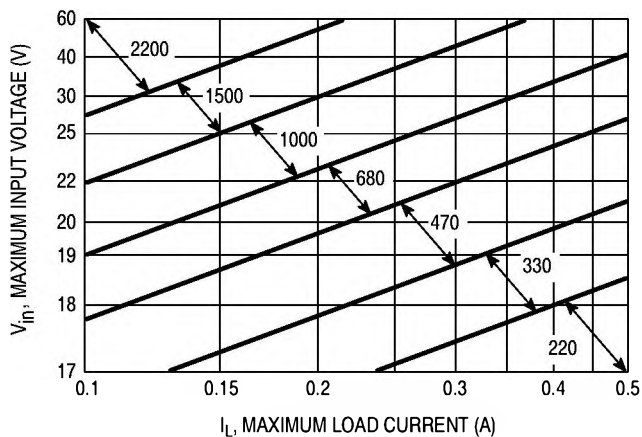

Figure 22. LM2574-15

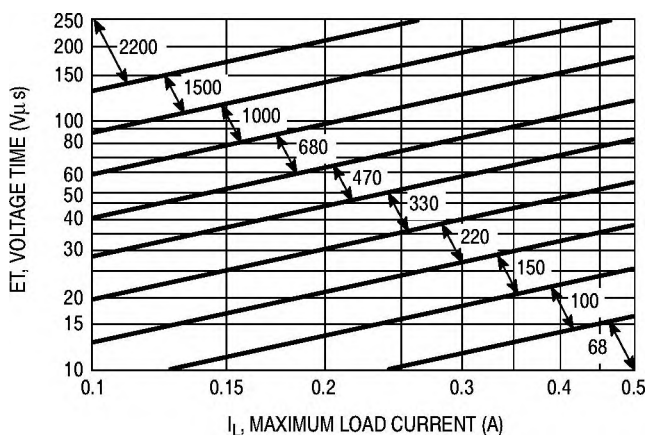

Figure 23. LM2574-ADJ

LM2574

Table 1. Diode Selection Guide gives an overview about through-hole diodes for an effective design. Device listed in bold are available from ON Semiconductor

V_R	1.0 Amp Diodes	
	Schottky	Fast Recovery
20 V	1N5817 MBR120P	MUR110 (rated to 100 V)
30 V	1N5818 MBR130P	
40 V	1N5819 MBR140P	
50 V	MBR150	
60 V	MBR160	

Table 2. Inductor Selection Guide

Inductor Value	Pulse Engineering	Tech 39	Renco	NPI
68 μ H	*	55 258 SN	RL-1284-68	NP5915
100 μ H	*	55 308 SN	RL-1284-100	NP5916
150 μ H	52625	55 356 SN	RL-1284-150	NP5917
220 μ H	52626	55 406 SN	RL-1284-220	NP5918/5919
330 μ H	52627	55 454 SN	RL-1284-330	NP5920/5921
470 μ H	52628	*	RL-1284-470	NP5922
680 μ H	52629	55 504 SN	RL-1284-680	NP5923
1000 μ H	52631	55 554 SN	RL-1284-1000	*
1500 μ H	*	*	RL-1284-1500	*
2200 μ H	*	*	RL-1284-2200	*

* : Contact Manufacturer

Table 3. Example of Several Inductor Manufacturers Phone/Fax Numbers

Pulse Engineering Inc.	Phone Fax	+ 1-619-674-8100 + 1-619-674-8262
Pulse Engineering Inc. Europe	Phone Fax	+ 353-9324-107 + 353-9324-459
Renco Electronics Inc.	Phone Fax	+ 1-516-645-5828 + 1-516-586-5562
Tech 39	Phone Fax	+ 33-1-4115-1681 + 33-1-4709-5051
NPI/APC	Phone Fax	+ 44-634-290-588

EXTERNAL COMPONENTS

Input Capacitor (C_{in})***The Input Capacitor Should Have a Low ESR***

For stable operation of the switch mode converter a low ESR (Equivalent Series Resistance) aluminium or solid tantalum bypass capacitor is needed between the input pin and the ground pin, to prevent large voltage transients from appearing at the input. It must be located near the regulator and use short leads. With most electrolytic capacitors, the capacitance value decreases and the ESR increases with lower temperatures. For reliable operation in temperatures below -25°C larger values of the input capacitor may be needed. Also paralleling a ceramic or solid tantalum capacitor will increase the regulator stability at cold temperatures.

RMS Current Rating of C_{in}

The important parameter of the input capacitor is the RMS current rating. Capacitors that are physically large and have large surface area will typically have higher RMS current ratings. For a given capacitor value, a higher voltage electrolytic capacitor will be physically larger than a lower voltage capacitor, and thus be able to dissipate more heat to the surrounding air, and therefore will have a higher RMS current rating. The consequences of operating an electrolytic capacitor beyond the RMS current rating is a shortened operating life. In order to assure maximum capacitor operating lifetime, the capacitor's RMS ripple current rating should be:

$$I_{\text{rms}} > 1.2 \times d \times I_{\text{Load}}$$

where d is the duty cycle, for a continuous mode buck regulator

$$d = \frac{t_{\text{on}}}{T} = \frac{V_{\text{out}}}{V_{\text{in}}}$$

and $d = \frac{t_{\text{on}}}{T} = \frac{|V_{\text{out}}|}{|V_{\text{out}}| + V_{\text{in}}}$ for a buck-boost regulator.

Output Capacitor (C_{out})

For low output ripple voltage and good stability, low ESR output capacitors are recommended. An output capacitor has two main functions: it filters the output and provides regulator loop stability. The ESR of the output capacitor and the peak-to-peak value of the inductor ripple current are the main factors contributing to the output ripple voltage value. Standard aluminium electrolytics could be adequate for some applications but for quality design, low ESR types are recommended.

An aluminium electrolytic capacitor's ESR value is related to many factors, such as the capacitance value, the voltage rating, the physical size and the type of construction. In most cases, the higher voltage electrolytic capacitors have lower ESR value. Often capacitors with much higher

voltage ratings may be needed to provide low ESR values, that are required for low output ripple voltage.

The Output Capacitor Requires an ESR Value that has an Upper and Lower Limit

As mentioned above, a low ESR value is needed for low output ripple voltage, typically 1% to 2% of the output voltage. But if the selected capacitor's ESR is extremely low (below 0.03Ω), there is a possibility of an unstable feedback loop, resulting in oscillation at the output. This situation can occur when a tantalum capacitor, that can have a very low ESR, is used as the only output capacitor.

At Low Temperatures, Put in Parallel Aluminium Electrolytic Capacitors with Tantalum Capacitors

Electrolytic capacitors are not recommended for temperatures below -25°C . The ESR rises dramatically at cold temperatures and typically rises 3 times at -25°C and as much as 10 times at -40°C . Solid tantalum capacitors have much better ESR spec at cold temperatures and are recommended for temperatures below -25°C . They can be also used in parallel with aluminium electrolytics. The value of the tantalum capacitor should be about 10% or 20% of the total capacitance. The output capacitor should have at least 50% higher RMS ripple current rating at 52 kHz than the peak-to-peak inductor ripple current.

Catch Diode***Locate the Catch Diode Close to the LM2574***

The LM2574 is a step-down buck converter, it requires a fast diode to provide a return path for the inductor current when the switch turns off. This diode must be located close to the LM2574 using short leads and short printed circuit traces to avoid EMI problems.

Use a Schottky or a Soft Switching Ultra-Fast Recovery Diode

Since the rectifier diodes are very significant source of losses within switching power supplies, choosing the rectifier that best fits into the converter design is an important process. Schottky diodes provide the best performance because of their fast switching speed and low forward voltage drop.

They provide the best efficiency especially in low output voltage applications (5.0 V and lower). Another choice could be Fast-Recovery, or Ultra-Fast Recovery diodes. It has to be noted, that some types of these diodes with an abrupt turnoff characteristic may cause instability or EMI troubles.

A fast-recovery diode with soft recovery characteristics can better fulfill some quality, low noise design requirements. Table 1 provides a list of suitable diodes for the LM2574 regulator. Standard 50/60 Hz rectifier diodes, such as the 1N4001 series or 1N5400 series are NOT suitable.

Inductor

The magnetic components are the cornerstone of all switching power supply designs. The style of the core and the winding technique used in the magnetic component's design have a great influence on the reliability of the overall power supply.

Using an improper or poorly designed inductor can cause high voltage spikes generated by the rate of transitions in current within the switching power supply, and the possibility of core saturation can arise during an abnormal operational mode. Voltage spikes can cause the semiconductors to enter avalanche breakdown and the part can instantly fail if enough energy is applied. It can also cause significant RFI (Radio Frequency Interference) and EMI (Electro-Magnetic Interference) problems.

Continuous and Discontinuous Mode of Operation

The LM2574 step-down converter can operate in both the continuous and the discontinuous modes of operation. The regulator works in the continuous mode when loads are relatively heavy, the current flows through the inductor continuously and never falls to zero. Under light load conditions, the circuit will be forced to the discontinuous mode when inductor current falls to zero for certain period of time (see Figure 24 and Figure 25). Each mode has distinctively different operating characteristics, which can affect the regulator performance and requirements. In many cases the preferred mode of operation is the continuous mode. It offers greater output power, lower peak currents in the switch, inductor and diode, and can have a lower output ripple voltage. On the other hand it does require larger inductor values to keep the inductor current flowing continuously, especially at low output load currents and/or high input voltages.

To simplify the inductor selection process, an inductor selection guide for the LM2574 regulator was added to this data sheet (Figures 19 through 23). This guide assumes that the regulator is operating in the continuous mode, and selects an inductor that will allow a peak-to-peak inductor ripple current to be a certain percentage of the maximum design load current. This percentage is allowed to change as different design load currents are selected. For light loads (less than approximately 0.2 A) it may be desirable to operate the regulator in the discontinuous mode, because the inductor value and size can be kept relatively low. Consequently, the percentage of inductor peak-to-peak

current increases. This discontinuous mode of operation is perfectly acceptable for this type of switching converter. Any buck regulator will be forced to enter discontinuous mode if the load current is light enough.

Selecting the Right Inductor Style

Some important considerations when selecting a core type are core material, cost, the output power of the power supply, the physical volume the inductor must fit within, and the amount of EMI (Electro-Magnetic Interference) shielding that the core must provide. There are many different styles of inductors available, such as pot core, E-core, toroid and bobbin core, as well as different core materials such as ferrites and powdered iron from different manufacturers.

For high quality design regulators the toroid core seems to be the best choice. Since the magnetic flux is contained within the core, it generates less EMI, reducing noise problems in sensitive circuits. The least expensive is the bobbin core type, which consists of wire wound on a ferrite rod core. This type of inductor generates more EMI due to the fact that its core is open, and the magnetic flux is not contained within the core.

When multiple switching regulators are located on the same printed circuit board, open core magnetics can cause interference between two or more of the regulator circuits, especially at high currents due to mutual coupling. A toroid, pot core or E-core (closed magnetic structure) should be used in such applications.

Do Not Operate an Inductor Beyond its Maximum Rated Current

Exceeding an inductor's maximum current rating may cause the inductor to overheat because of the copper wire losses, or the core may saturate. Core saturation occurs when the flux density is too high and consequently the cross sectional area of the core can no longer support additional lines of magnetic flux.

This causes the permeability of the core to drop, the inductance value decreases rapidly and the inductor begins to look mainly resistive. It has only the dc resistance of the winding. This can cause the switch current to rise very rapidly and force the LM2574 internal switch into cycle-by-cycle current limit, thus reducing the dc output load current. This can also result in overheating of the inductor and/or the LM2574. Different inductor types have different saturation characteristics, and this should be kept in mind when selecting an inductor.

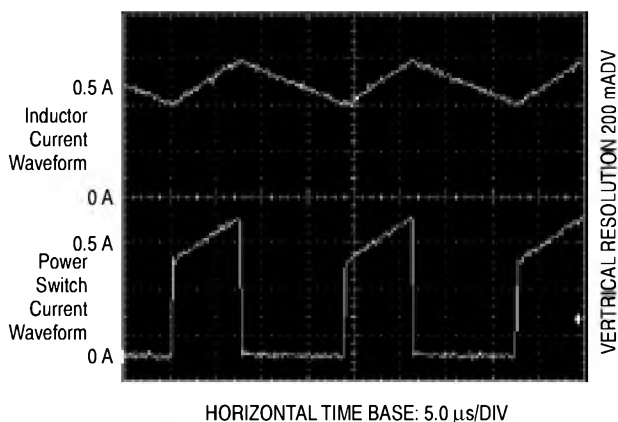

Figure 24. Continuous Mode Switching Current Waveforms

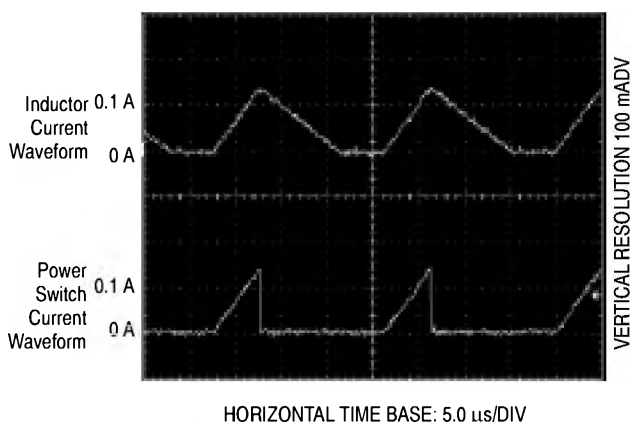

Figure 25. Continuous Mode Switching Current Waveforms

GENERAL RECOMMENDATIONS

Output Voltage Ripple and Transients

Source of the Output Ripple

Since the LM2574 is a switch mode power supply regulator, its output voltage, if left unfiltered, will contain a sawtooth ripple voltage at the switching frequency. The output ripple voltage value ranges from 0.5% to 3% of the output voltage. It is caused mainly by the inductor sawtooth ripple current multiplied by the ESR of the output capacitor.

Short Voltage Spikes and How to Reduce Them

The regulator output voltage may also contain short voltage spikes at the peaks of the sawtooth waveform (see Figure 26). These voltage spikes are present because of the fast switching action of the output switch, and the parasitic inductance of the output filter capacitor. There are some other important factors such as wiring inductance, stray capacitance, as well as the scope probe used to evaluate these transients, all these contribute to the amplitude of these spikes. To minimize these voltage spikes, low inductance capacitors should be used, and their lead lengths must be kept short. The importance of quality printed circuit board layout design should also be highlighted.

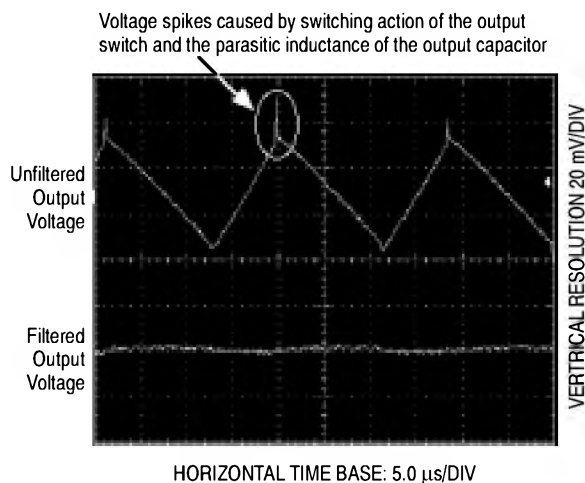

Figure 26. Output Ripple Voltage Waveforms

Minimizing the Output Ripple

In order to minimize the output ripple voltage it is possible to enlarge the inductance value of the inductor L1 and/or to use a larger value output capacitor. There is also another way to smooth the output by means of an additional LC filter (20 μ H, 100 μ F), that can be added to the output (see Figure 35) to further reduce the amount of output ripple and transients. With such a filter it is possible to reduce the output ripple voltage transients 10 times or more. Figure 26 shows the difference between filtered and unfiltered output waveforms of the regulator shown in Figure 34.

The upper waveform is from the normal unfiltered output of the converter, while the lower waveform shows the output ripple voltage filtered by an additional LC filter.

Heatsinking and Thermal Considerations

The LM2574 is available in both 8-pin DIP and SO-16L packages. When used in the typical application the copper lead frame conducts the majority of the heat from the die, through the leads, to the printed circuit copper. The copper and the board are the heatsink for this package and the other heat producing components, such as the catch diode and inductor.

For the best thermal performance, wide copper traces should be used and all ground and unused pins should be soldered to generous amounts of printed circuit board copper, such as a ground plane. Large areas of copper provide the best transfer of heat to the surrounding air. One exception to this is the output (switch) pin, which should not have large areas of copper in order to minimize coupling to sensitive circuitry.

Additional improvement in heat dissipation can be achieved even by using of double sided or multilayer boards which can provide even better heat path to the ambient. Using a socket for the 8-pin DIP package is not recommended because socket represents an additional thermal resistance, and as a result the junction temperature will be higher.

Since the current rating of the LM2574 is only 0.5 A, the total package power dissipation for this switcher is quite low, ranging from approximately 0.1 W up to 0.75 W under varying conditions. In a carefully engineered printed circuit board, the through-hole DIP package can easily dissipate up to 0.75 W, even at ambient temperatures of 60°C, and still keep the maximum junction temperature below 125°C.

Thermal Analysis and Design

The following procedure must be performed to determine the operating junction temperature. First determine:

1. $P_{D(max)}$ – maximum regulator power dissipation in the application.
2. $T_{A(max)}$ – maximum ambient temperature in the application.
3. $T_{J(max)}$ – maximum allowed junction temperature (125°C for the LM2574). For a conservative design, the maximum junction temperature should not exceed 110°C to assure safe operation. For every additional +10°C temperature rise that the junction must withstand, the estimated operating lifetime of the component is halved.
4. $R_{\theta JC}$ – package thermal resistance junction–case.
5. $R_{\theta JA}$ – package thermal resistance junction–ambient.

(Refer to Absolute Maximum Ratings on page 1279 of this data sheet or $R_{\theta JC}$ and $R_{\theta JA}$ values).

The following formula is to calculate the approximate total power dissipated by the LM2574:

$$P_D = (V_{in} \times I_Q) + d \times I_{Load} \times V_{sat}$$

where d is the duty cycle and for buck converter

$$d = \frac{t_{on}}{T} = \frac{V_O}{V_{in}}$$

I_Q (quiescent current) and V_{sat} can be found in the LM2574 data sheet.

V_{in} is minimum input voltage applied.

V_O is the regulator output voltage.

I_{Load} is the load current.

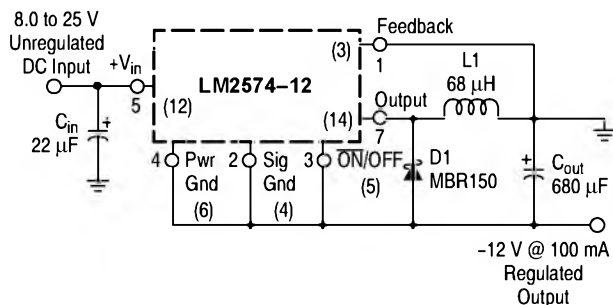

Figure 27. Inverting Buck–Boost Develops –12 V

The dynamic switching losses during turn–on and turn–off can be neglected if a proper type catch diode is used. The junction temperature can be determined by the following expression:

$$T_J = (R_{\theta JA})(P_D) + T_A$$

where $(R_{\theta JA})(P_D)$ represents the junction temperature rise caused by the dissipated power and T_A is the maximum ambient temperature.

Some Aspects That can Influence Thermal Design

It should be noted that the package thermal resistance and the junction temperature rise numbers are all approximate, and there are many factors that will affect these numbers, such as PC board size, shape, thickness, physical position, location, board temperature, as well as whether the surrounding air is moving or still. At higher power levels the thermal resistance decreases due to the increased air current activity.

Other factors are trace width, total printed circuit copper area, copper thickness, single– or double–sided, multilayer board, the amount of solder on the board or even color of the traces.

The size, quantity and spacing of other components on the board can also influence its effectiveness to dissipate the heat. Some of them, like the catch diode or the inductor will generate some additional heat.

ADDITIONAL APPLICATIONS

Inverting Regulator

An inverting buck–boost regulator using the LM2574–12 is shown in Figure 27. This circuit converts a positive input voltage to a negative output voltage with a common ground by bootstrapping the regulators ground to the negative output voltage. By grounding the feedback pin, the regulator senses the inverted output voltage and regulates it.

In this example the LM2574–12 is used to generate a –12 V output. The maximum input voltage in this case cannot exceed 28 V because the maximum voltage appearing across the regulator is the absolute sum of the input and output voltages and this must be limited to a maximum of 40 V.

This circuit configuration is able to deliver approximately 0.1 A to the output when the input voltage is 8.0 V or higher. At lighter loads the minimum input voltage required drops to approximately 4.7 V, because the buck–boost regulator topology can produce an output voltage that, in its absolute value, is either greater or less than the input voltage.

Since the switch currents in this buck–boost configuration are higher than in the standard buck converter topology, the available output current is lower.

This type of buck–boost inverting regulator can also require a larger amount of startup input current, even for light loads. This may overload an input power source with a current limit less than 0.6 A.

Because of the relatively high startup currents required by this inverting regulator topology, the use of a delayed startup or an undervoltage lockout circuit is recommended.

While using a delayed startup arrangement, the input capacitor can charge up to a higher voltage before the switch–mode regulator begins to operate.

The high input current needed for startup is now partially supplied by the input capacitor C_{in} .

Design Recommendations:

The inverting regulator operates in a different manner than the buck converter and so a different design procedure has to be used to select the inductor $L1$ or the output capacitor C_{out} .

The output capacitor values must be larger than what is normally required for buck converter designs. Low input voltages or high output currents require a large value output capacitor (in the range of thousands of μF).

The recommended range of inductor values for the inverting converter design is between $68 \mu H$ and $220 \mu H$. To select an inductor with an appropriate current rating, the inductor peak current has to be calculated.

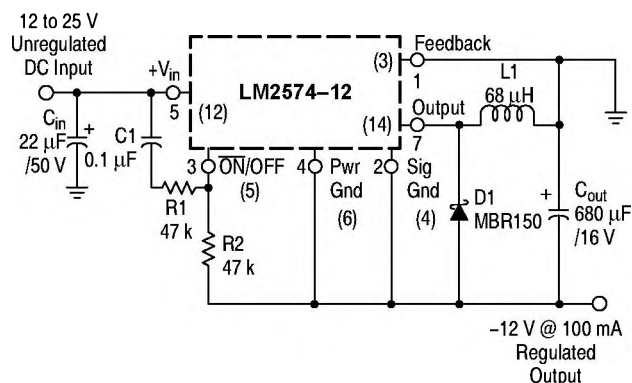

Figure 28. Inverting Buck-Boost Regulator with Delayed Startup

The following formula is used to obtain the peak inductor current:

$$I_{peak} \approx \frac{I_{Load}(V_{in} + |V_O|)}{V_{in}} + \frac{V_{in} \times t_{on}}{2L_1}$$

where $t_{on} = \frac{|V_O|}{V_{in} + |V_O|} \times \frac{1.0}{f_{osc}}$, and $f_{osc} = 52 \text{ kHz}$.

Under normal continuous inductor current operating conditions, the worst case occurs when V_{in} is minimal.

It has been already mentioned above, that in some situations, the delayed startup or the undervoltage lockout features could be very useful. A delayed startup circuit applied to a buck-boost converter is shown in Figure 28. Figure 34 in the "Undervoltage Lockout" section describes an undervoltage lockout feature for the same converter topology.

With the inverting configuration, the use of the $\overline{ON/OFF}$ pin requires some level shifting techniques. This is caused

by the fact, that the ground pin of the converter IC is no longer at ground. Now, the $\overline{ON/OFF}$ pin threshold voltage (1.3 V approximately) has to be related to the negative output voltage level. There are many different possible shutdown methods, two of them are shown in Figures 29 and 30.

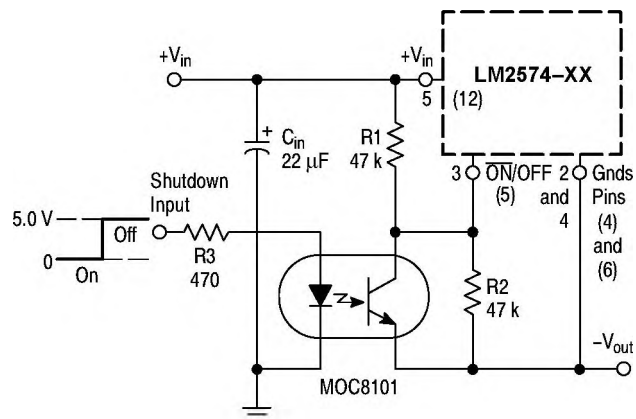

NOTE: This picture does not show the complete circuit.

Figure 29. Inverting Buck-Boost Regulator Shutdown Circuit Using an Optocoupler

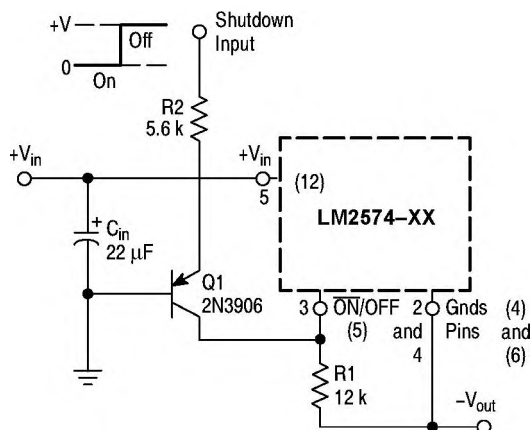

NOTE: This picture does not show the complete circuit.

Figure 30. Inverting Buck-Boost Regulator Shutdown Circuit Using a PNP Transistor

Negative Boost Regulator

This example is a variation of the buck-boost topology and it is called negative boost regulator. This regulator experiences relatively high switch current, especially at low input voltages. The internal switch current limiting results in lower output load current capability.

LM2574

The circuit in Figure 31 shows the negative boost configuration. The input voltage in this application ranges from -5.0 to -12 V and provides a regulated -12 V output. If the input voltage is greater than -12 V, the output will rise above -12 V accordingly, but will not damage the regulator.

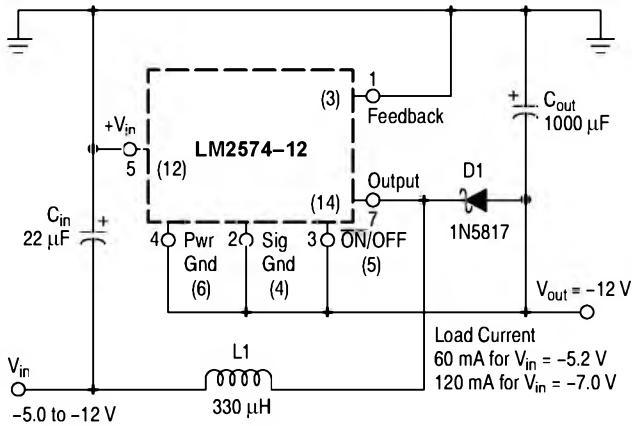

Figure 31. Negative Boost Regulator

Design Recommendations:

The same design rules as for the previous inverting buck-boost converter can be applied. The output capacitor C_{out} must be chosen larger than what would be required for a standard buck converter. Low input voltages or high output currents require a large value output capacitor (in the range of thousands of μF). The recommended range of inductor values for the negative boost regulator is the same as for inverting converter design.

Another important point is that these negative boost converters cannot provide any current limiting load protection in the event of a short in the output so some other means, such as a fuse, may be necessary to provide the load protection.

Delayed Startup

There are some applications, like the inverting regulator already mentioned above, which require a higher amount of startup current. In such cases, if the input power source is limited, this delayed startup feature becomes very useful.

To provide a time delay between the time when the input voltage is applied and the time when the output voltage comes up, the circuit in Figure 32 can be used. As the input voltage is applied, the capacitor $C1$ charges up, and the voltage across the resistor $R2$ falls down. When the voltage on the $\overline{\text{ON/OFF}}$ pin falls below the threshold value 1.3 V, the regulator starts up. Resistor $R1$ is included to limit the maximum voltage applied to the $\overline{\text{ON/OFF}}$ pin. It reduces the power supply noise sensitivity, and also limits the capacitor $C1$ discharge current, but its use is not mandatory.

When a high 50 Hz or 60 Hz (100 Hz or 120 Hz respectively) ripple voltage exists, a long delay time can cause some problems by coupling the ripple into the $\overline{\text{ON/OFF}}$ pin, the regulator could be switched periodically on and off with the line (or double) frequency.

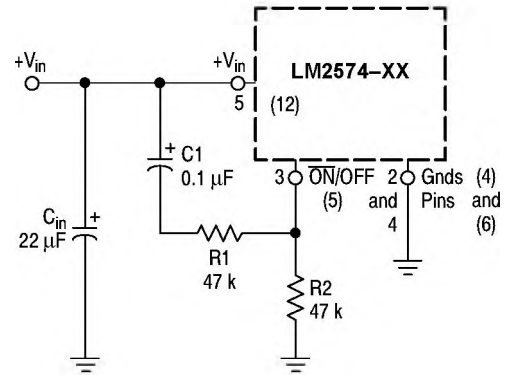

NOTE: This picture does not show the complete circuit.

Figure 32. Delayed Startup Circuitry

Undervoltage Lockout

Some applications require the regulator to remain off until the input voltage reaches a certain threshold level. Figure 33 shows an undervoltage lockout circuit applied to a buck regulator. A version of this circuit for buck-boost converter is shown in Figure 34. Resistor $R3$ pulls the $\overline{\text{ON/OFF}}$ pin high and keeps the regulator off until the input voltage reaches a predetermined threshold level, which is determined by the following expression:

$$V_{th} \approx V_{Z1} + \left(1.0 + \frac{R2}{R1}\right) V_{BE}(Q1)$$

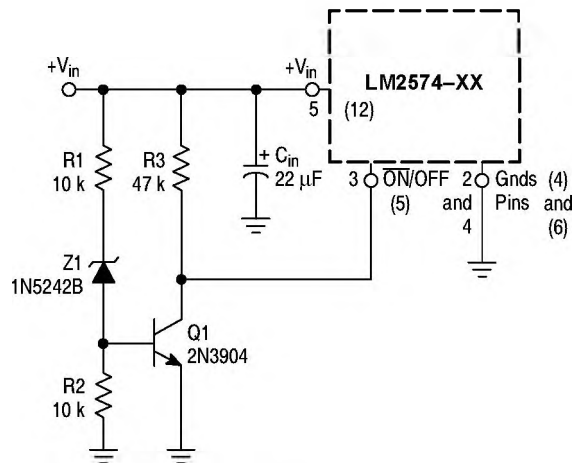

NOTE: This picture does not show the complete circuit.

Figure 33. Undervoltage Lockout Circuit for Buck Converter

LM2574

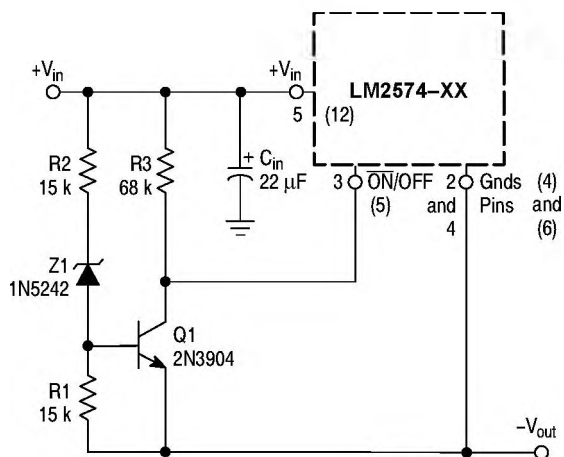

NOTE: This picture does not show the complete circuit (see Figure 27).

Figure 34. Undervoltage Lockout Circuit for Buck-Boost Converter

Adjustable Output, Low-Ripple Power Supply

A 0.5 A output current capability power supply that features an adjustable output voltage is shown in Figure 35.

This regulator delivers 0.5 A into 1.2 to 35 V output. The input voltage ranges from roughly 3.0 to 40 V. In order to achieve a 10 or more times reduction of output ripple, an additional L-C filter is included in this circuit.

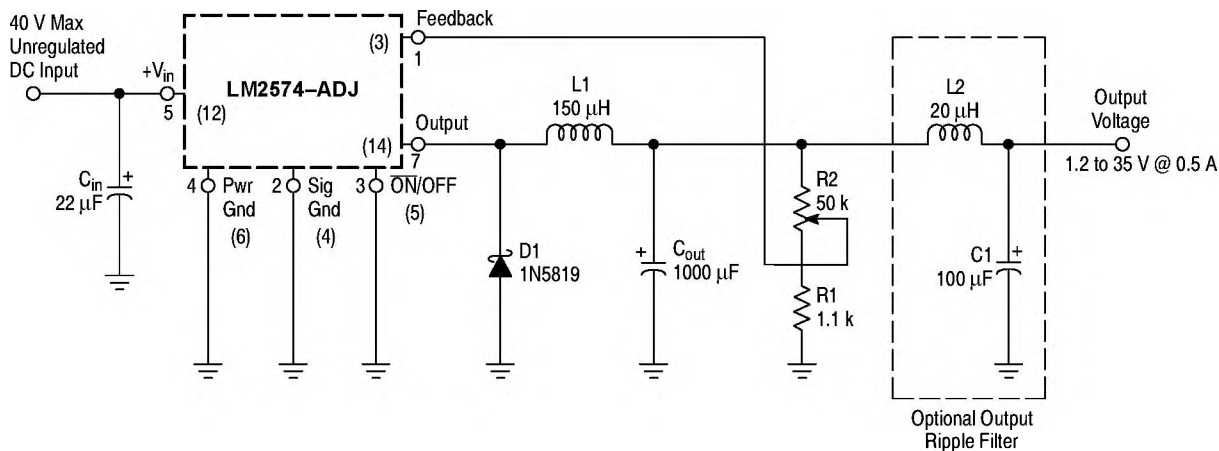

Figure 35. 1.2 to 35 V Adjustable 500 mA Power Supply with Low Output Ripple

LM2574

The LM2574-5 Step-Down Voltage Regulator with 5.0 V @ 0.5 A Output Power Capability. Typical Application With Through-Hole PC Board Layout

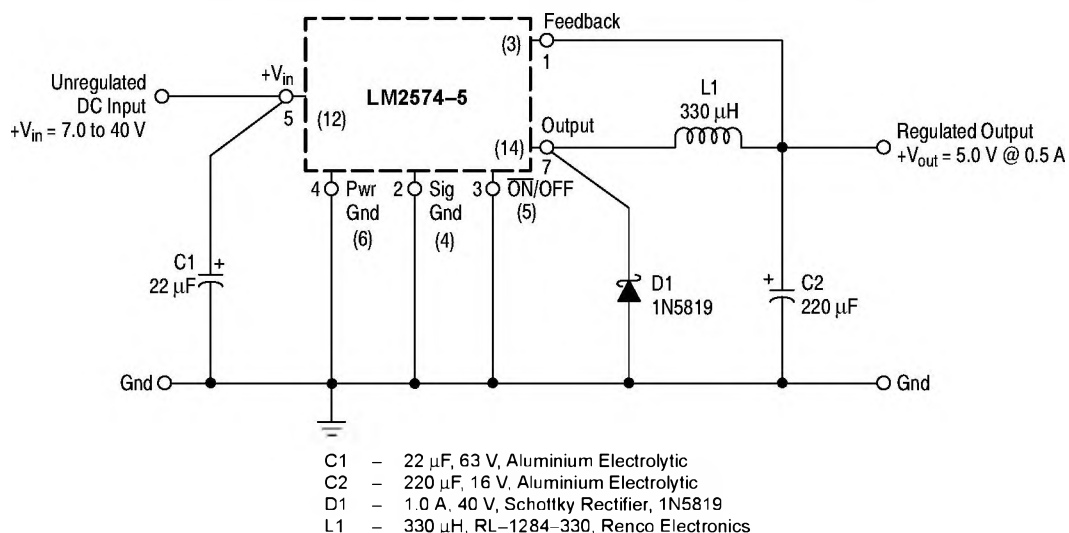
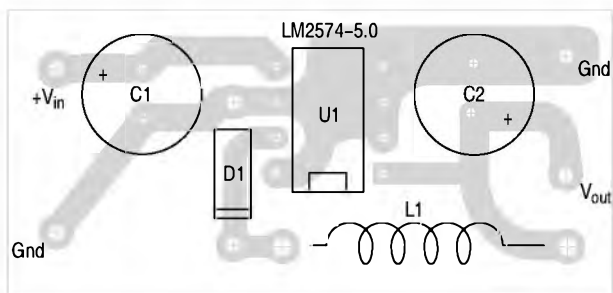
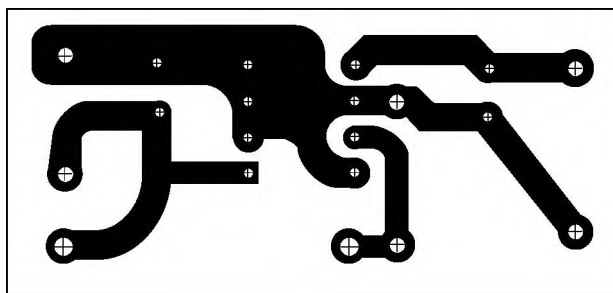

Figure 36. Schematic Diagram of the LM2574-5 Step-Down Converter



NOTE: Not to scale.

Figure 37. PC Board Layout Component Side



NOTE: Not to scale.

Figure 38. PC Board Layout Copper Side

LM2574

The LM2574-ADJ Step-Down Voltage Regulator with 5.0 V @ 0.5 A Output Power Capability Typical Application With Through-Hole PC Board Layout

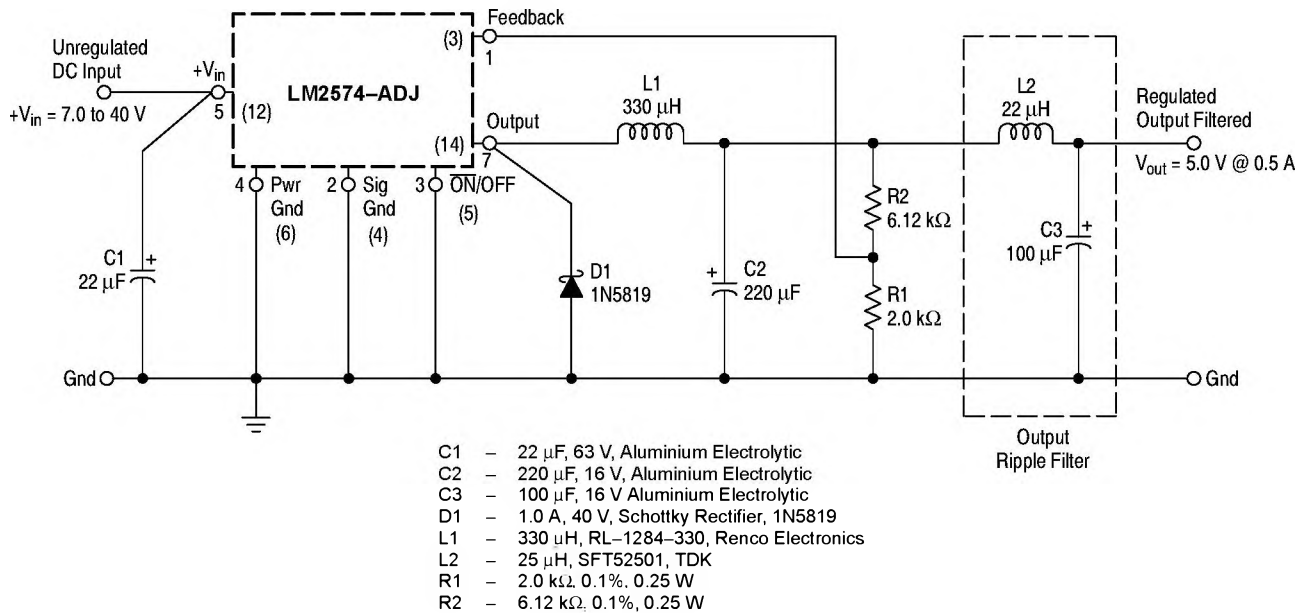
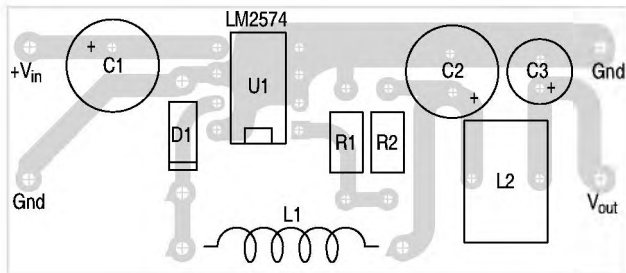
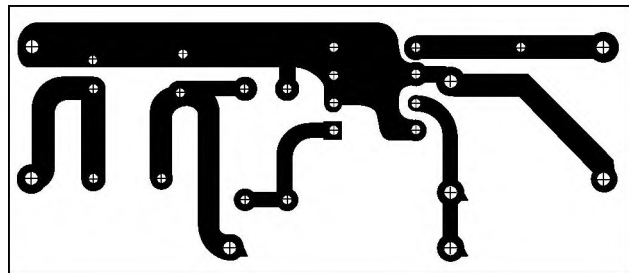

Figure 39. Schematic Diagram of the 5.0 V @ 0.5 A Step-Down Converter Using the LM2574-ADJ (An additional LC filter is included to achieve low output ripple voltage)



NOTE: Not to scale.

Figure 40. PC Board Layout Component Side



NOTE: Not to scale.

Figure 41. PC Board Layout Copper Side

References

- Marty Brown "Practical Switching Power Supply Design", Academic Press, Inc., San Diego 1990
- Ray Ridley "High Frequency Magnetics Design", Ridley Engineering, Inc. 1995

LM2574

ORDERING INFORMATION

Device	Nominal Output Voltage	Operating Temperature Range	Package	Shipping
LM2574DW-ADJ	1.23 V to 37 V	$T_A = -40^{\circ}$ to $+125^{\circ}\text{C}$	SO-16W	47 Units/Rail
LM2574DW-ADJR2			SO-16W	1000 Units/Tape & Reel
LM2574N-ADJ			PDIP-8	50 Units/Rail
LM2574N-3.3	3.3 V		PDIP-8	50 Units/Rail
LM2574N-5	5.0 V		PDIP-8	50 Units/Rail
LM2574N-12	12 V		PDIP-8	50 Units/Rail
LM2574N-15	15 V		PDIP-8	50 Units/Rail

MARKING DIAGRAMS

SO-16W DW SUFFIX CASE 751G

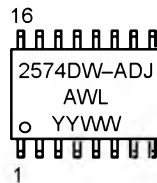

PDIP-8 N SUFFIX CASE 626

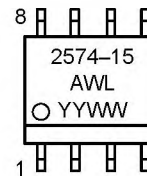
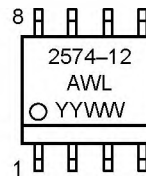
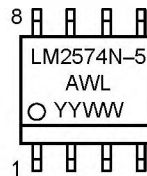
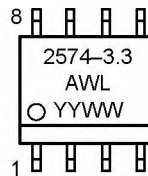
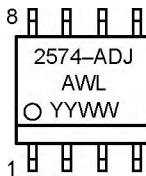

A = Assembly Location
 WL = Wafer Lot
 YY = Year
 WW = Work Week