

LM111/LM211/LM311 Voltage Comparator

General Description

The LM111, LM211 and LM311 are voltage comparators that have input currents nearly a thousand times lower than devices like the LM106 or LM710. They are also designed to operate over a wider range of supply voltages: from standard $\pm 15V$ op amp supplies down to the single 5V supply used for IC logic. Their output is compatible with RTL, DTL and TTL as well as MOS circuits. Further, they can drive lamps or relays, switching voltages up to 50V at currents as high as 50 mA.

Both the inputs and the outputs of the LM111, LM211 or the LM311 can be isolated from system ground, and the output can drive loads referred to ground, the positive supply or the negative supply. Offset balancing and strobe capability are provided and outputs can be wire OR'ed. Although slower than the LM106 and LM710 (200 ns response time vs

40 ns) the devices are also much less prone to spurious oscillations. The LM111 has the same pin configuration as the LM106 and LM710.

The LM211 is identical to the LM111, except that its performance is specified over a $-25^{\circ}C$ to $+85^{\circ}C$ temperature range instead of $-55^{\circ}C$ to $+125^{\circ}C$. The LM311 has a temperature range of $0^{\circ}C$ to $+70^{\circ}C$.

Features

- Operates from single 5V supply
- Input current: 150 nA max. over temperature
- Offset current: 20 nA max. over temperature
- Differential input voltage range: $\pm 30V$
- Power consumption: 135 mW at $\pm 15V$

Typical Applications**

Offset Balancing

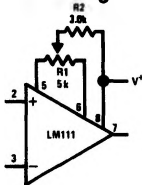

Strobing

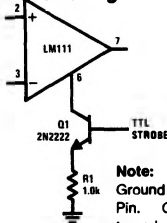

**Note: Pin connections shown on schematic diagram and typical applications are for H08 metal can package.

Increasing Input Stage Current*

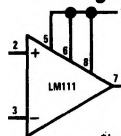

*Increases typical common mode slew from 7.0V/ μs to 18V/ μs .

Detector for Magnetic Transducer

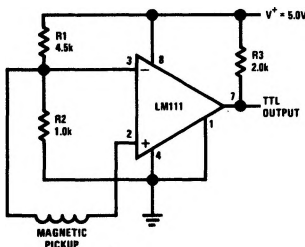

Digital Transmission Isolator

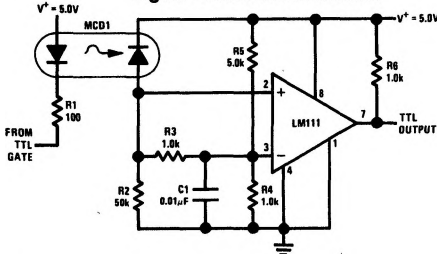

Relay Driver with Strobe

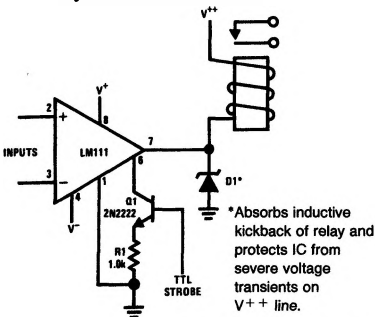

*Absorbs inductive kickback of relay and protects IC from severe voltage transients on V+ + line.

Note: Do Not Ground Strobe Pin.

Strobing off Both Input* and Output Stages

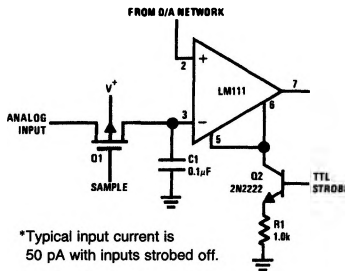

*Typical input current is 50 pA with inputs strobed off.

Note: Do Not Ground Strobe Pin.

TL/H/5704-1

Absolute Maximum Ratings for the LM111/LM211

If Military/Aerospace specified devices are required, please contact the National Semiconductor Sales Office/Distributors for availability and specifications. (Note 7)

Total Supply Voltage (V_{B4})	36V
Output to Negative Supply Voltage (V_{74})	50V
Ground to Negative Supply Voltage (V_{14})	30V
Differential Input Voltage	$\pm 30V$
Input Voltage (Note 1)	$\pm 15V$
Output Short Circuit Duration	10 sec
Operating Temperature Range LM111	$-55^{\circ}C$ to $125^{\circ}C$
LM211	$-25^{\circ}C$ to $85^{\circ}C$

Lead Temperature (Soldering, 10 sec)	$260^{\circ}C$
Voltage at Strobe Pin	$V+ - 5V$
Soldering Information	
Dual-In-Line Package	
Soldering (10 seconds)	$260^{\circ}C$
Small Outline Package	
Vapor Phase (60 seconds)	$215^{\circ}C$
Infrared (15 seconds)	$220^{\circ}C$
See AN-450 "Surface Mounting Methods and Their Effect on Product Reliability" for other methods of soldering surface mount devices.	
ESD Rating (Note 8)	300V

Electrical Characteristics for the LM111 and LM211 (Note 3)

Parameter	Conditions	Min	Typ	Max	Units
Input Offset Voltage (Note 4)	$T_A = 25^{\circ}C, R_S \leq 50k$		0.7	3.0	mV
Input Offset Current	$T_A = 25^{\circ}C$		4.0	10	nA
Input Bias Current	$T_A = 25^{\circ}C$		60	100	nA
Voltage Gain	$T_A = 25^{\circ}C$	40	200		V/mV
Response Time (Note 5)	$T_A = 25^{\circ}C$		200		ns
Saturation Voltage	$V_{IN} \leq -5$ mV, $I_{OUT} = 50$ mA $T_A = 25^{\circ}C$		0.75	1.5	V
Strobe ON Current (Note 6)	$T_A = 25^{\circ}C$		2.0	5.0	mA
Output Leakage Current	$V_{IN} \geq 5$ mV, $V_{OUT} = 35V$ $T_A = 25^{\circ}C, I_{STROBE} = 3$ mA		0.2	10	nA
Input Offset Voltage (Note 4)	$R_S \leq 50$ k			4.0	mV
Input Offset Current (Note 4)				20	nA
Input Bias Current				150	nA
Input Voltage Range	$V+ = 15V, V- = -15V$, Pin 7 Pull-Up May Go To 5V	-14.5	13.8,-14.7	13.0	V
Saturation Voltage	$V+ \geq 4.5V, V- = 0$ $V_{IN} \leq -6$ mV, $I_{OUT} \leq 8$ mA		0.23	0.4	V
Output Leakage Current	$V_{IN} \geq 5$ mV, $V_{OUT} = 35V$		0.1	0.5	μA
Positive Supply Current	$T_A = 25^{\circ}C$		5.1	6.0	mA
Negative Supply Current	$T_A = 25^{\circ}C$		4.1	5.0	mA

Note 1: This rating applies for ± 15 supplies. The positive input voltage limit is 30V above the negative supply. The negative input voltage limit is equal to the negative supply voltage or 30V below the positive supply, whichever is less.

Note 2: The maximum junction temperature of the LM111 is $150^{\circ}C$, while that of the LM211 is $110^{\circ}C$. For operating at elevated temperatures, devices in the H08 package must be derated based on a thermal resistance of $165^{\circ}C/W$, junction to ambient, or $20^{\circ}C/W$, junction to case. The thermal resistance of the dual-in-line package is $110^{\circ}C/W$, junction to ambient.

Note 3: These specifications apply for $V_S = \pm 15V$ and Ground pin at ground, and $-55^{\circ}C \leq T_A \leq +125^{\circ}C$, unless otherwise stated. With the LM211, however, all temperature specifications are limited to $-25^{\circ}C \leq T_A \leq +85^{\circ}C$. The offset voltage, offset current and bias current specifications apply for any supply voltage from a single 5V supply up to $\pm 15V$ supplies.

Note 4: The offset voltages and offset currents given are the maximum values required to drive the output within a volt of either supply with a 1 mA load. Thus, these parameters define an error band and take into account the worst-case effects of voltage gain and R_S .

Note 5: The response time specified (see definitions) is for a 100 mV input step with 5 mV overdrive.

Note 6: This specification gives the range of current which must be drawn from the strobe pin to ensure the output is properly disabled. Do not short the strobe pin to ground; it should be current driven at 3 to 5 mA.

Note 7: Refer to RETS111X for the LM111H, LM111J and LM111J-8 military specifications.

Note 8: Human body model, 1.5 k Ω in series with 100 pF.

Absolute Maximum Ratings for the LM311

If Military/Aerospace specified devices are required, please contact the National Semiconductor Sales Office/Distributors for availability and specifications.

Total Supply Voltage (V_{S4})	36V
Output to Negative Supply Voltage (V_{74})	40V
Ground to Negative Supply Voltage (V_{14})	30V
Differential Input Voltage	$\pm 30V$
Input Voltage (Note 1)	$\pm 15V$
Power Dissipation (Note 2)	500 mW
ESD Rating (Note 7)	300V

Output Short Circuit Duration	10 sec
Operating Temperature Range	0° to 70°C
Storage Temperature Range	-65°C to 150°C
Lead Temperature (soldering, 10 sec)	260°C
Voltage at Strobe Pin	$V^+ - 5V$
Soldering Information	
Dual-In-Line Package	
Soldering (10 seconds)	260°C
Small Outline Package	
Vapor Phase (60 seconds)	215°C
Infrared (15 seconds)	220°C

See AN-450 "Surface Mounting Methods and Their Effect on Product Reliability" for other methods of soldering surface mount devices.

Electrical Characteristics for the LM311 (Note 3)

Parameter	Conditions	Min	Typ	Max	Units
Input Offset Voltage (Note 4)	$T_A = 25^\circ\text{C}$, $R_S \leq 50k$		2.0	7.5	mV
Input Offset Current (Note 4)	$T_A = 25^\circ\text{C}$		6.0	50	nA
Input Bias Current	$T_A = 25^\circ\text{C}$		100	250	nA
Voltage Gain	$T_A = 25^\circ\text{C}$	40	200		V/mV
Response Time (Note 5)	$T_A = 25^\circ\text{C}$		200		ns
Saturation Voltage	$V_{IN} \leq -10 \text{ mV}$, $I_{OUT} = 50 \text{ mA}$ $T_A = 25^\circ\text{C}$		0.75	1.5	V
Strobe ON Current (Note 6)	$T_A = 25^\circ\text{C}$		2.0	5.0	mA
Output Leakage Current	$V_{IN} \geq 10 \text{ mV}$, $V_{OUT} = 35V$ $T_A = 25^\circ\text{C}$, $I_{STROBE} = 3 \text{ mA}$ $V^- = \text{Pin } 1 = -5V$		0.2	50	nA
Input Offset Voltage (Note 4)	$R_S \leq 50k$			10	mV
Input Offset Current (Note 4)				70	nA
Input Bias Current				300	nA
Input Voltage Range		-14.5	13.8, -14.7	13.0	V
Saturation Voltage	$V^+ \geq 4.5V$, $V^- = 0$ $V_{IN} \leq -10 \text{ mV}$, $I_{OUT} \leq 8 \text{ mA}$		0.23	0.4	V
Positive Supply Current	$T_A = 25^\circ\text{C}$		5.1	7.5	mA
Negative Supply Current	$T_A = 25^\circ\text{C}$		4.1	5.0	mA

Note 1: This rating applies for $\pm 15V$ supplies. The positive input voltage limit is 30V above the negative supply. The negative input voltage limit is equal to the negative supply voltage or 30V below the positive supply, whichever is less.

Note 2: The maximum junction temperature of the LM311 is 110°C. For operating at elevated temperature, devices in the H08 package must be derated based on a thermal resistance of 165°C/W, junction to ambient, or 20°C/W, junction to case. The thermal resistance of the dual-in-line package is 100°C/W, junction to ambient.

Note 3: These specifications apply for $V_S = \pm 15V$ and Pin 1 at ground, and $0^\circ\text{C} < T_A < +70^\circ\text{C}$, unless otherwise specified. The offset voltage, offset current and bias current specifications apply for any supply voltage from a single 5V supply up to $\pm 15V$ supplies.

Note 4: The offset voltages and offset currents given are the maximum values required to drive the output within a volt of either supply with 1 mA load. Thus, these parameters define an error band and take into account the worst-case effects of voltage gain and R_S .

Note 5: The response time specified (see definitions) is for a 100 mV input step with 5 mV overdrive.

Note 6: This specification gives the range of current which must be drawn from the strobe pin to ensure the output is properly disabled. Do not short the strobe pin to ground; it should be current driven at 3 to 5 mA.

Note 7: Human body model, 1.5 k Ω in series with 100 pF.

LM111/LM211 Typical Performance Characteristics

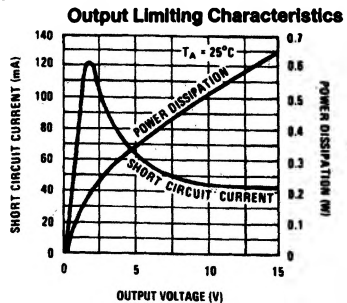
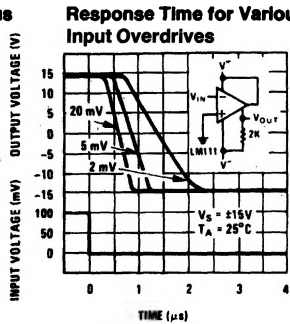
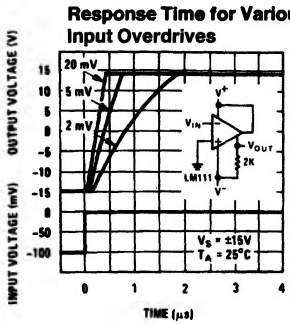
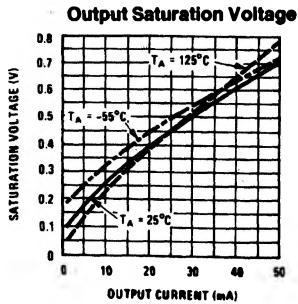
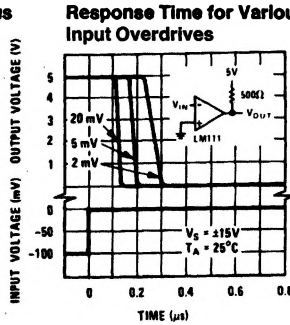
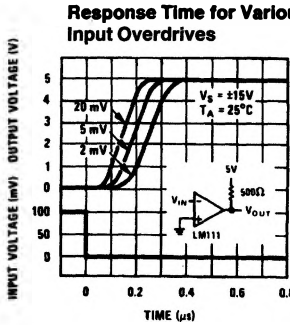
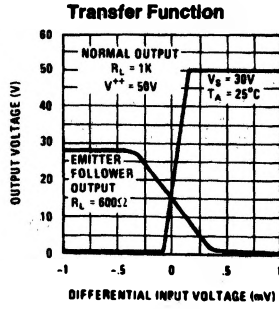
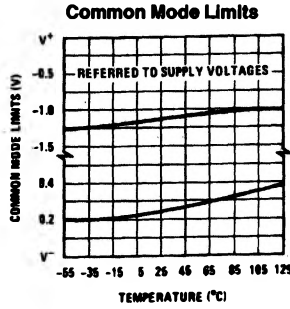
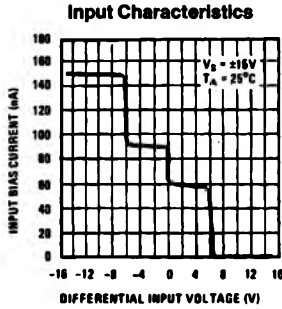
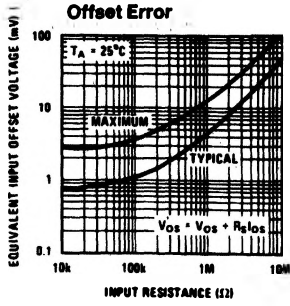
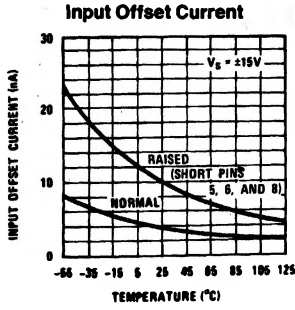
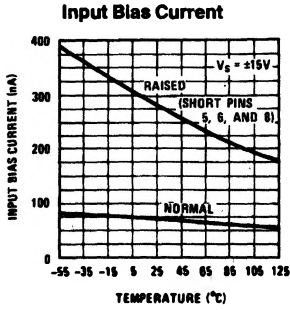

LM111/LM211 Typical Performance Characteristics (Continued)

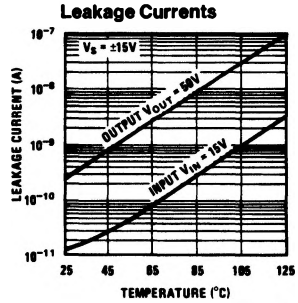
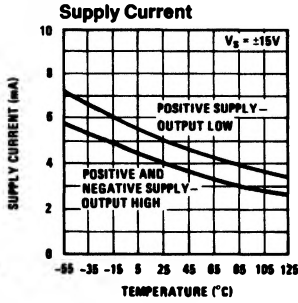
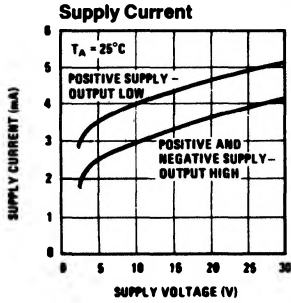

TL/H/5704-3

LM311 Typical Performance Characteristics

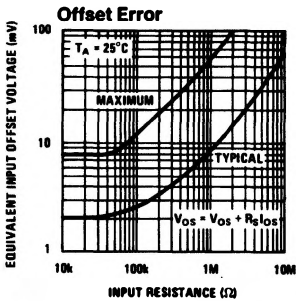
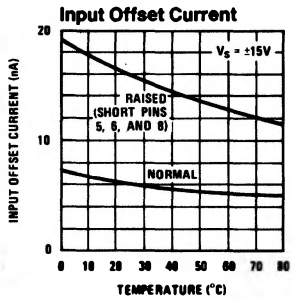
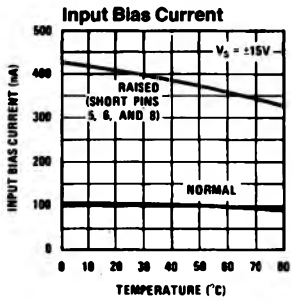

TL/H/5704-8

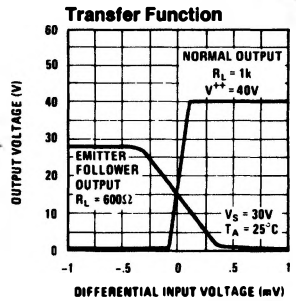
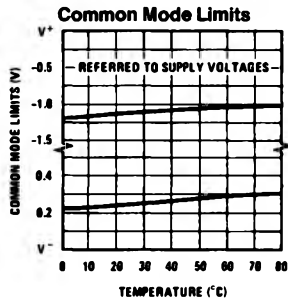
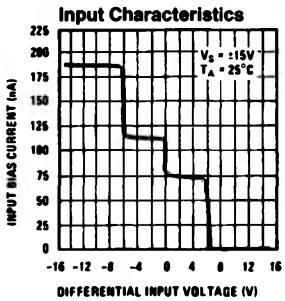

TL/H/5704-9

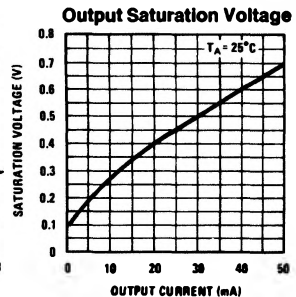
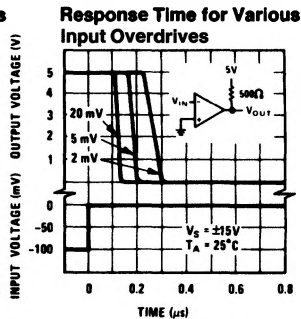
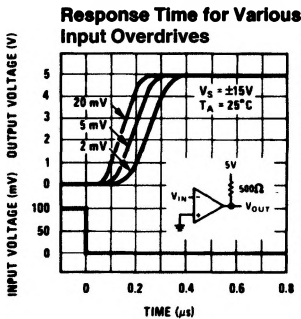

TL/H/5704-10

LM311 Typical Performance Characteristics (Continued)

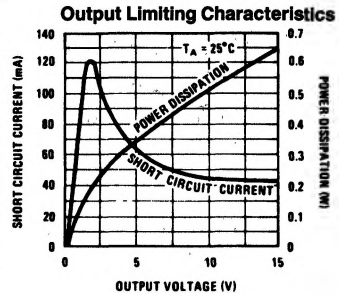
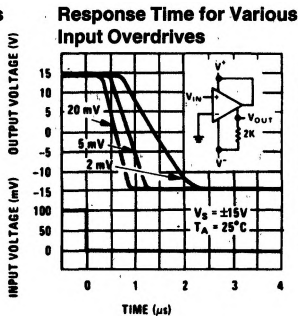
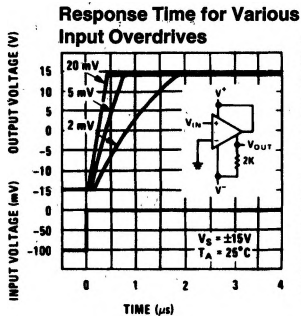

TL/H/5704-11

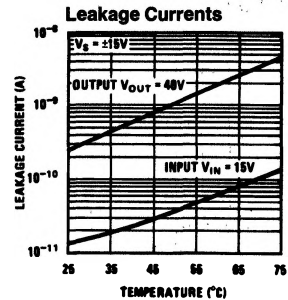
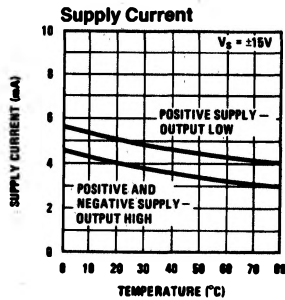
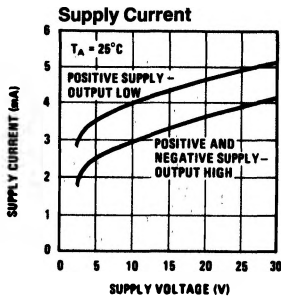

TL/H/5704-12

Application Hints

CIRCUIT TECHNIQUES FOR AVOIDING OSCILLATIONS IN COMPARATOR APPLICATIONS

When a high-speed comparator such as the LM111 is used with fast input signals and low source impedances, the output response will normally be fast and stable, assuming that the power supplies have been bypassed (with 0.1 μ F disc capacitors), and that the output signal is routed well away from the inputs (pins 2 and 3) and also away from pins 5 and 6.

However, when the input signal is a voltage ramp or a slow sine wave, or if the signal source impedance is high (1 k Ω to 100 k Ω), the comparator may burst into oscillation near the crossing-point. This is due to the high gain and wide bandwidth of comparators like the LM111. To avoid oscillation or instability in such a usage, several precautions are recommended, as shown in *Figure 1* below.

1. The trim pins (pins 5 and 6) act as unwanted auxiliary inputs. If these pins are not connected to a trim-pot, they should be shorted together. If they are connected to a trim-pot, a 0.01 μ F capacitor C1 between pins 5 and 6 will minimize the susceptibility to AC coupling. A smaller capacitor is used if pin 5 is used for positive feedback as in *Figure 1*.
2. Certain sources will produce a cleaner comparator output waveform if a 100 pF to 1000 pF capacitor C2 is connected directly across the input pins.
3. When the signal source is applied through a resistive network, R_S , it is usually advantageous to choose an R_S' of substantially the same value, both for DC and for dynamic (AC) considerations. Carbon, tin-oxide, and metal-film resistors have all been used successfully in comparator input circuitry. Inductive wirewound resistors are not suitable.

4. When comparator circuits use input resistors (eg. summing resistors), their value and placement are particularly important. In all cases the body of the resistor should be close to the device or socket. In other words there should be very little lead length or printed-circuit foil run between comparator and resistor to radiate or pick up signals. The same applies to capacitors, pots, etc. For example, if $R_S = 10$ k Ω , as little as 5 inches of lead between the resistors and the input pins can result in oscillations that are very hard to damp. Twisting these input leads tightly is the only (second best) alternative to placing resistors close to the comparator.
5. Since feedback to almost any pin of a comparator can result in oscillation, the printed-circuit layout should be engineered thoughtfully. Preferably there should be a groundplane under the LM111 circuitry, for example, one side of a double-layer circuit card. Ground foil (or, positive supply or negative supply foil) should extend between the output and the inputs, to act as a guard. The foil connections for the inputs should be as small and compact as possible, and should be essentially surrounded by ground foil on all sides, to guard against capacitive coupling from any high-level signals (such as the output). If pins 5 and 6 are not used, they should be shorted together. If they are connected to a trim-pot, the trim-pot should be located, at most, a few inches away from the LM111, and the 0.01 μ F capacitor should be installed. If this capacitor cannot be used, a shielding printed-circuit foil may be advisable between pins 6 and 7. The power supply bypass capacitors should be located within a couple inches of the LM111. (Some other comparators require the power-supply bypass to be located immediately adjacent to the comparator.)

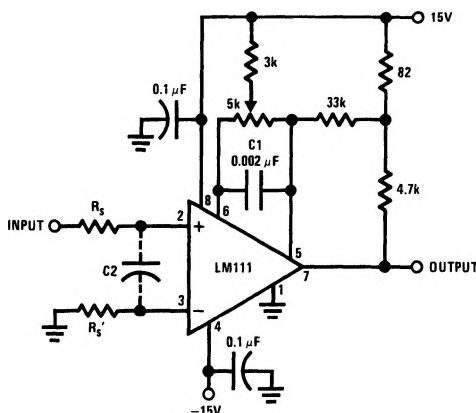

TL/H/5704-29

Pin connections shown are for LM111H in the H08 hermetic package

FIGURE 1. Improved Positive Feedback

Application Hints (Continued)

6. It is a standard procedure to use hysteresis (positive feedback) around a comparator, to prevent oscillation, and to avoid excessive noise on the output because the comparator is a good amplifier for its own noise. In the circuit of *Figure 2*, the feedback from the output to the positive input will cause about 3 mV of hysteresis. However, if R_S is larger than 100Ω , such as $50\text{ k}\Omega$, it would not be reasonable to simply increase the value of the positive feedback resistor above $510\text{ k}\Omega$. The circuit of *Figure 3* could be used, but it is rather awkward. See the notes in paragraph 7 below.
7. When both inputs of the LM111 are connected to active signals, or if a high-impedance signal is driving the positive input of the LM111 so that positive feedback would be disruptive, the circuit of *Figure 1* is ideal. The positive

feedback is to pin 5 (one of the offset adjustment pins). It is sufficient to cause 1 to 2 mV hysteresis and sharp transitions with input triangle waves from a few Hz to hundreds of kHz. The positive-feedback signal across the 82Ω resistor swings 240 mV below the positive supply. This signal is centered around the nominal voltage at pin 5, so this feedback does not add to the V_{OS} of the comparator. As much as 8 mV of V_{OS} can be trimmed out, using the 5 k Ω pot and 3 k Ω resistor as shown.

8. These application notes apply specifically to the LM111, LM211, LM311, and LF111 families of comparators, and are applicable to all high-speed comparators in general, (with the exception that not all comparators have trim pins).

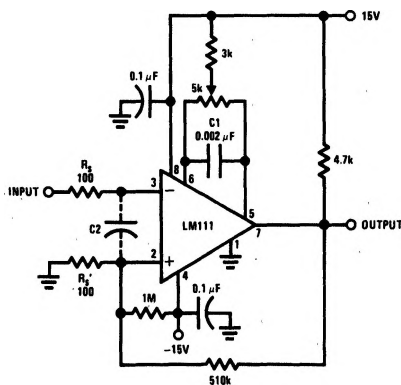

TL/H/5704-30

Pin connections shown are for LM111H in the H08 hermetic package

FIGURE 2. Conventional Positive Feedback

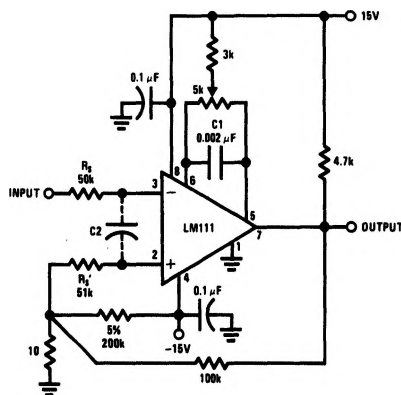

TL/H/5704-31

FIGURE 3. Positive Feedback with High Source Resistance

Typical Applications (Continued) (Pin numbers refer to H08 package)

Zero Crossing Detector Driving MOS Switch

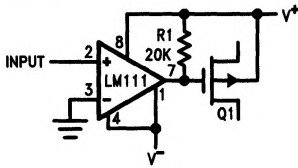

TL/H/5704-13

100 kHz Free Running Multivibrator

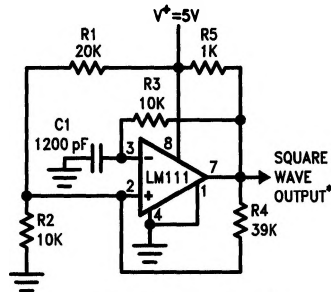

*TTL or DTL fanout of two

TL/H/5704-14

10 Hz to 10 kHz Voltage Controlled Oscillator

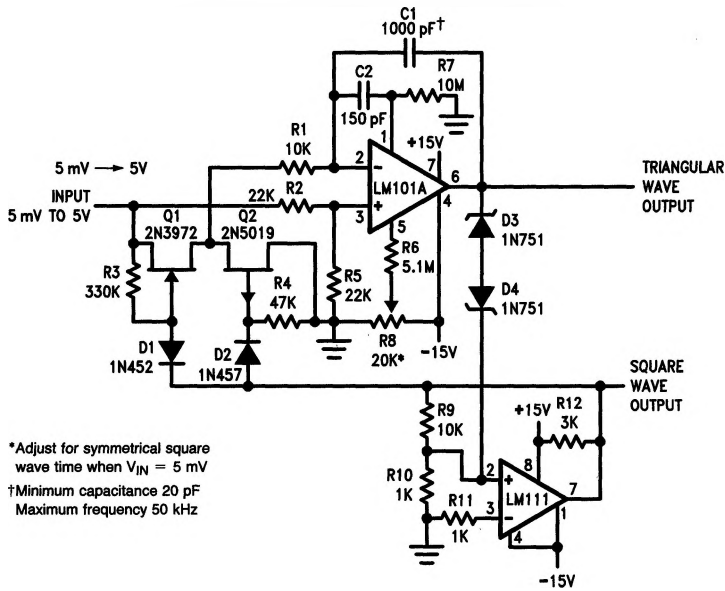

*Adjust for symmetrical square wave time when $V_{IN} = 5$ mV
 †Minimum capacitance 20 pF
 Maximum frequency 50 kHz

TL/H/5704-15

Driving Ground-Referred Load

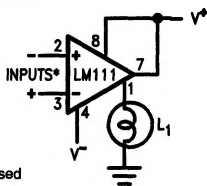

*Input polarity is reversed when using pin 1 as output.

TL/H/5704-16

Using Clamp Diodes to Improve Response

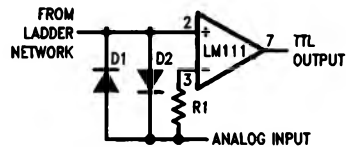

TL/H/5704-17

Typical Applications (Continued) (Pin numbers refer to H08 package)

TTL Interface with High Level Logic

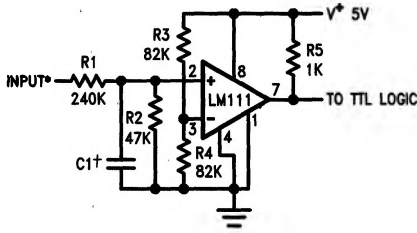

*Values shown are for a 0 to 30V logic swing and a 15V threshold.
 †May be added to control speed and reduce susceptibility to noise spikes.

TL/H/5704-18

Crystal Oscillator

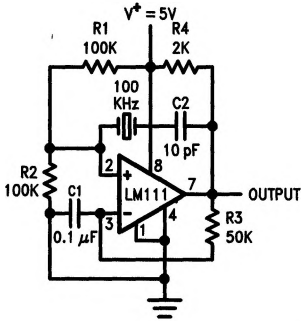

TL/H/5704-19

Comparator and Solenoid Driver

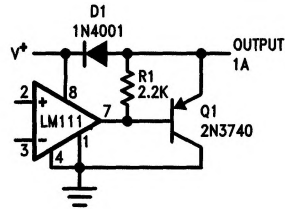

TL/H/5704-20

Precision Squarer

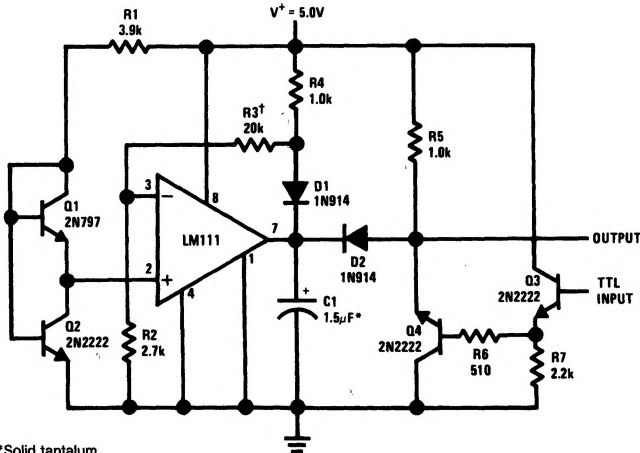

*Solid tantalum
 †Adjust to set clamp level

TL/H/5704-21

Low Voltage Adjustable Reference Supply

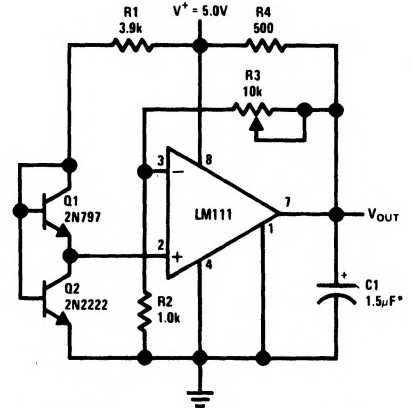

*Solid tantalum

TL/H/5704-22

Typical Applications (Continued) (Pin numbers refer to H08 package)

Positive Peak Detector

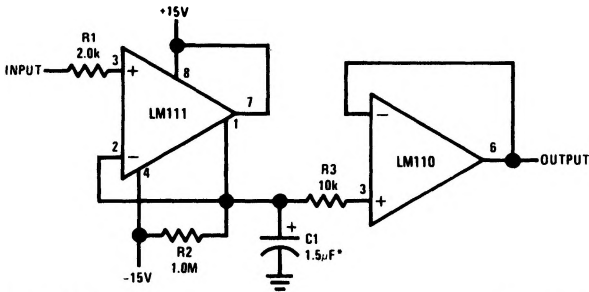

*Solid tantalum

TL/H/5704-23

Zero Crossing Detector Driving MOS Logic

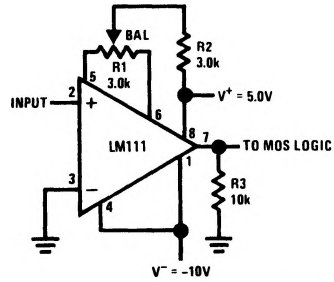

TL/H/5704-24

Negative Peak Detector

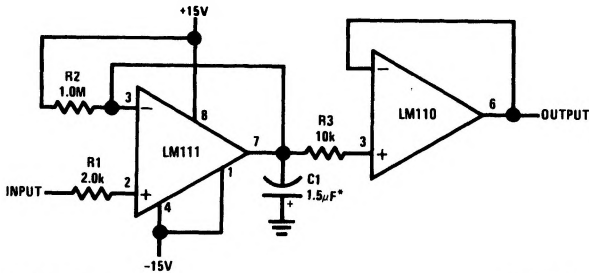

*Solid tantalum

TL/H/5704-25

Precision Photodiode Comparator

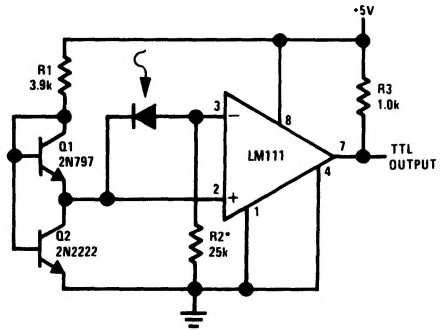

TL/H/5704-26

*R2 sets the comparison level. At comparison, the photodiode has less than 5 mV across it, decreasing leakages by an order of magnitude.

Typical Applications (Continued) (Pin numbers refer to H08 package)

Switching Power Amplifier

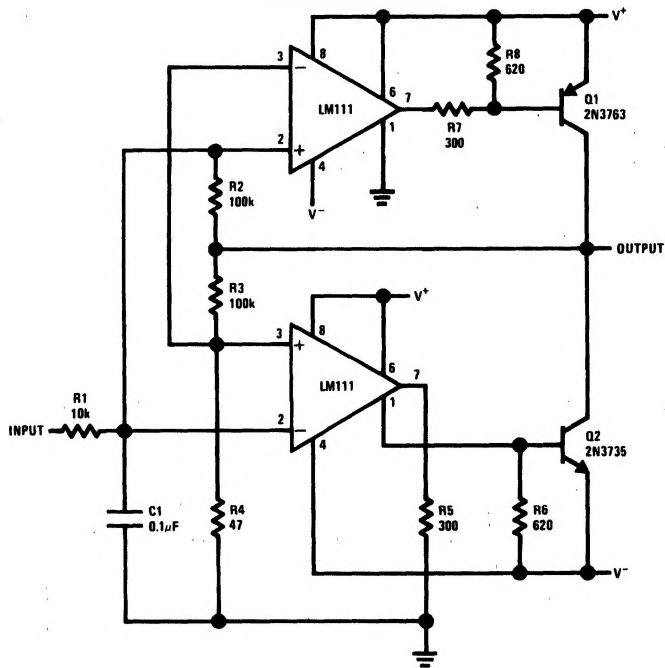

TL/H/5704-27

Switching Power Amplifier

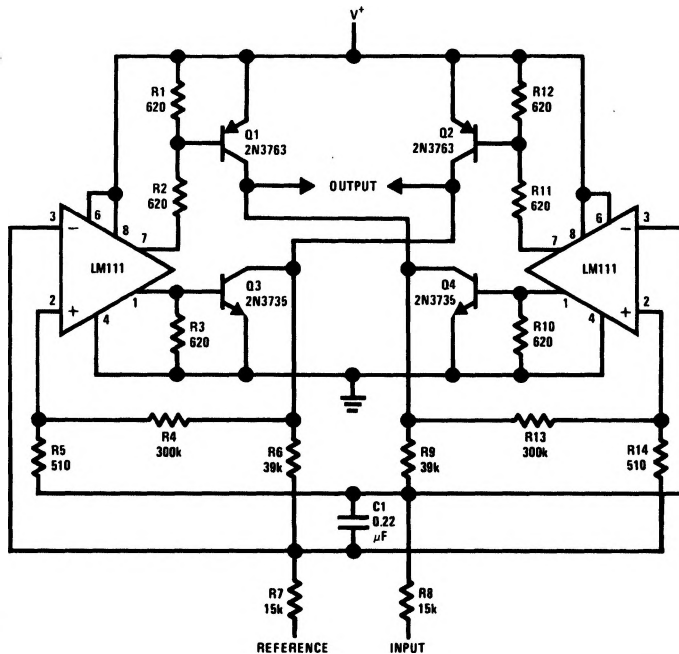

TL/H/5704-28

Schematic Diagram**

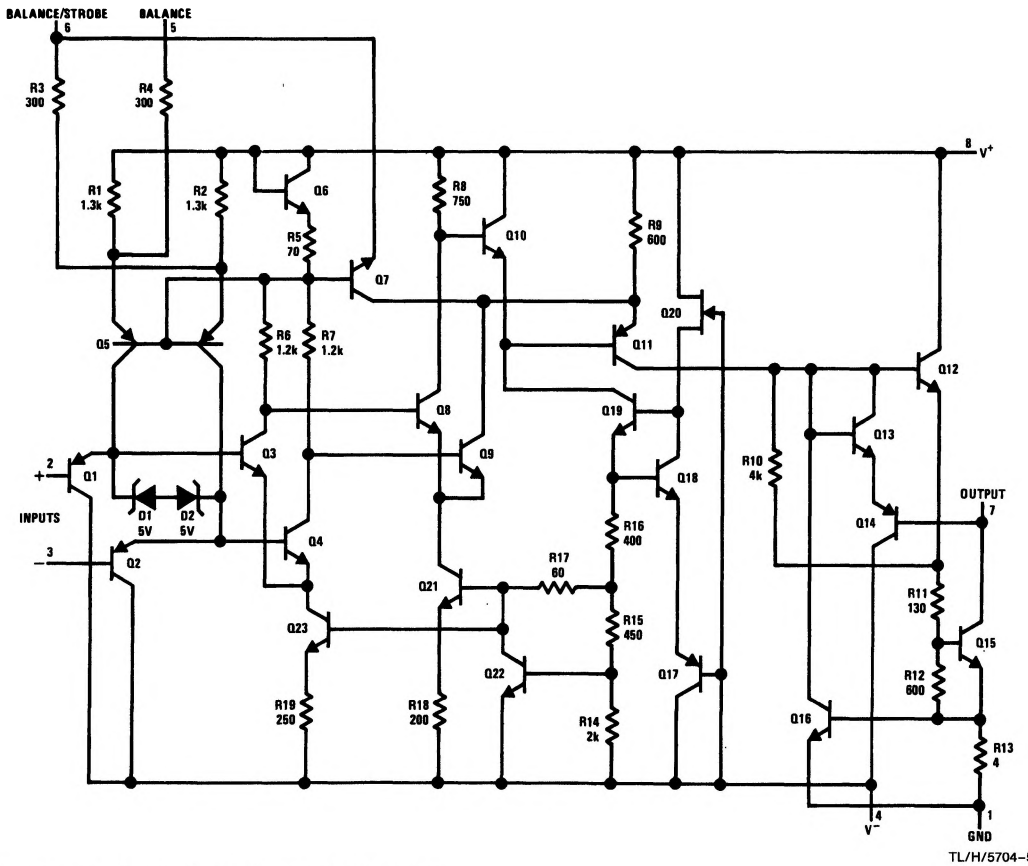

TL/H/5704-5

**Pin connections shown on schematic diagram are for H08 package.

Connection Diagrams*

Metal Can Package

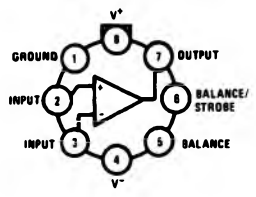

Top View

TL/H/5704-6

Note: Pin 4 connected to case

**Order Number LM111H, LM111H/883*, LM211H or LM311H
See NS Package Number H08C**

Dual-In-Line Package

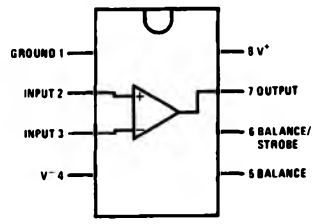

Top View

TL/H/5704-34

**Order Number LM111J-8, LM111J-8/883*, LM211J-8, LM211M, LM311M or LM311N
See NS Package Number J08A, M08A or N08E**

Dual-In-Line Package

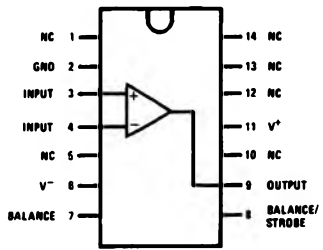

Top View

TL/H/5704-35

**Order Number LM111J/883* or LM311N-14
See NS Package Number J14A or N14A**

*Also available per JM38510/10304

Connection Diagrams (Continued)

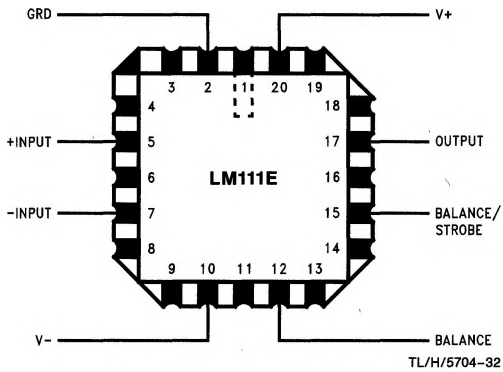

Order Number LM111E/883
See NS Package Number E20A

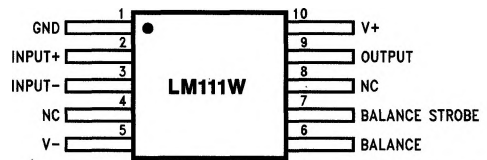

Order Number LM111W/883*
See NS Package Number W10A

TL/H/5704-33

*Also available per JM38510/10304