



LM1868 AM/FM Radio System

General Description

The combination of the LM1868 and an FM tuner will provide all the necessary functions for a 0.5 watt AM/FM radio. Included in the LM 1868 are the audio power amplifier, FM IF and detector, and the AM converter, IF, and detector. The device is suitable for both line operated and 9V battery applications.

Features

- DC selection of AM/FM mode
- Regulated supply
- Audio amplifier bandwidth decreased in AM mode, reducing amplifier noise in the AM band
- AM converter AGC for excellent overload characteristics
- Low current internal AM detector for low tweet radiation

Block Diagram

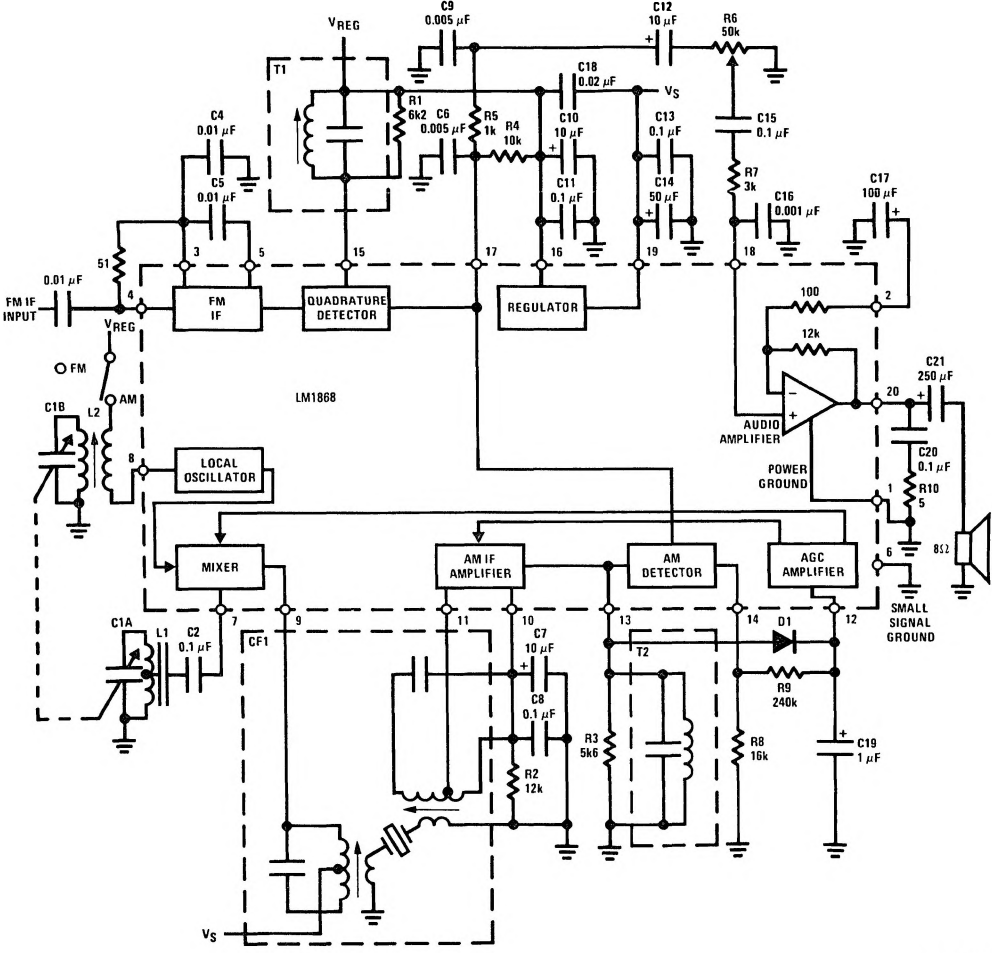

Order Number LM1868N
See NS Package Number N20A

TL/H/7909-1

Note: See table for coil data

Absolute Maximum Ratings

If Military/Aerospace specified devices are required, contact the National Semiconductor Sales Office/Distributors for availability and specifications.

Supply Voltage (Pin 19) 15V
 Package Dissipation 2.0W
 Above $T_A = 25^\circ\text{C}$, Derate Based on
 $T_{J(\text{MAX})} = 150^\circ\text{C}$ and $\theta_{JA} = 60^\circ\text{C/W}$

Storage Temperature Range -55°C to $+150^\circ\text{C}$
 Operating Temperature Range 0°C to $+70^\circ\text{C}$
 Lead Temperature (Soldering, 10 sec.) 260°C

Electrical Characteristics

Test Circuit, $T_A = 25^\circ\text{C}$, $V_S = 9\text{V}$, $R_L = 8\Omega$ (unless otherwise noted)

Parameter	Conditions	Min	Typ	Max	Units
STATIC CHARACTERISTICS $e_{AM} = 0$, $e_{FM} = 0$					
Supply Current	AM Mode, S1 in Position 1		22	30	mA
Regulator Output Voltage (Pin 16)		3.5	3.9	4.8	V
Operating Voltage Range		4.5		15	
DYNAMIC CHARACTERISTICS—AM MODE					
$f_{AM} = 1\text{ MHz}$, $f_{mod} = 1\text{ kHz}$, 30% Modulation, S1 in Position 1, $P_O = 50\text{ mW}$ unless noted					
Maximum Sensitivity	Measure e_{AM} for $P_O = 50\text{ mW}$, Maximum Volume	8		16	μV
Signal-to-Noise	$e_{AM} = 10\text{ mV}$	40	50		dB
Detector Output	$e_{AM} = 1\text{ mV}$ Measure at Top of Volume Control	40	60	85	mV
Overload Distortion	$e_{AM} = 50\text{ mV}$, 80% Modulation		2	10	%
Total Harmonic Distortion (THD)	$e_{AM} = 10\text{ mV}$		1.1	2	%
DYNAMIC CHARACTERISTICS—FM MODE $f_{FM} = 10.7\text{ MHz}$, $f_{mod} = 400\text{ Hz}$, $\Delta f = \pm 75\text{ kHz}$, $P_O = 50\text{ mW}$, S1 in Position 1					
-3 dB Limiting Sensitivity			15	45	μV
Signal-to-Noise Ratio	$e_{FM} = 10\text{ mV}$	50	64		dB
Detector Output	$e_{FM} = 10\text{ mV}$, $\Delta f = \pm 22.5\text{ kHz}$ Measure at Top of Volume Control	40	60	85	mV
AM Rejection	$e_{FM} = 10\text{ mV}$, 30% AM Modulation	40	50		dB
Total Harmonic Distortion (THD)	$e_{FM} = 10\text{ mV}$		1.1	2	%
DYNAMIC CHARACTERISTICS—AUDIO AMPLIFIER ONLY $f = 1\text{ kHz}$, $e_{AM} = 0$, $e_{FM} = 0$, S1 in Position 2					
Power Output	THD = 10%, $R_L = 8\Omega$ $V_S = 6\text{V}$ $V_S = 9\text{V}$	250 500	325 700		mW mW
Bandwidth	AM Mode, $P_O = 50\text{ mW}$ FM Mode, $P_O = 50\text{ mW}$		11 22		kHz kHz
Total Harmonic Distortion (THD)	$P_O = 50\text{ mW}$, FM Mode		0.2		%
Voltage Gain			41		dB

Typical Performance Characteristics

(Test Circuit) All curves are measured at audio output

Quiescent Supply Current vs Voltage

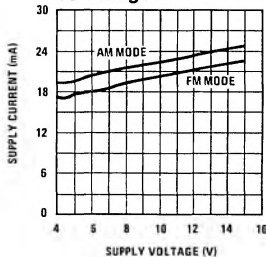

FM Limiting Characteristics

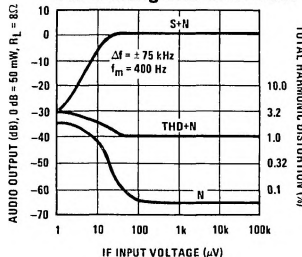

FM IF AM Rejection

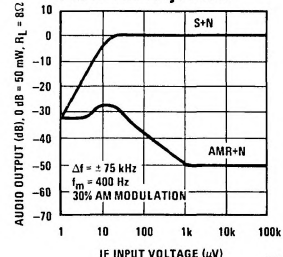

TL/H/7909-2

Typical Application

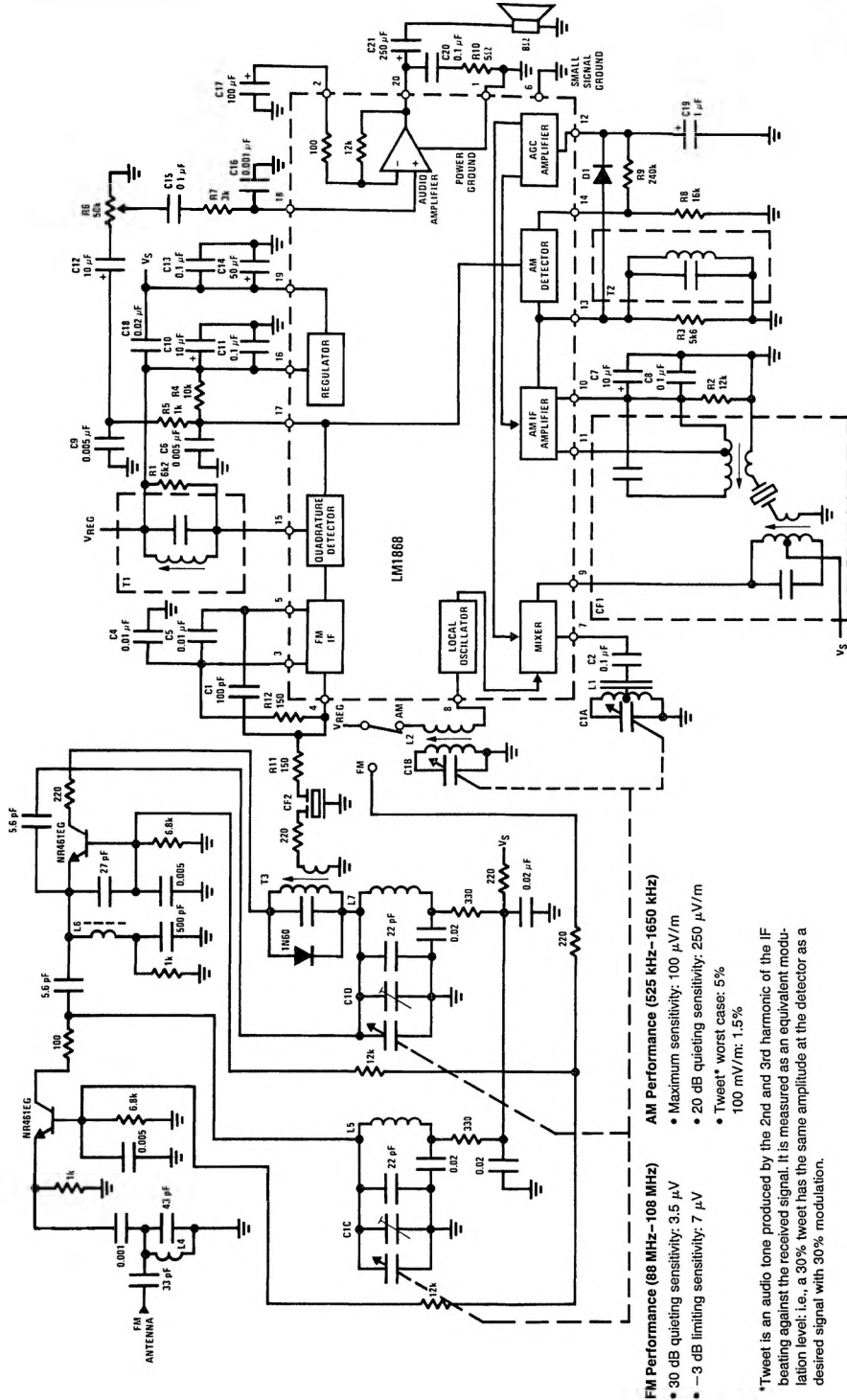

FM Performance (88 MHz-108 MHz)

- 30 dB quieting sensitivity: 3.5 µV
- -3 dB limiting sensitivity: 7 µV

AM Performance (525 kHz-1650 kHz)

- Maximum sensitivity: 100 µV/m
- 20 dB quieting sensitivity: 250 µV/m
- 100 mV/m: 1.5%
- *Tweeter worst case: 5%

*Tweeter is an audio tone produced by the 2nd and 3rd harmonic of the IF beating against the received signal. It is measured as an equivalent modulation level: i.e., a 30% tweeter has the same amplitude at the detector as a desired signal with 30% modulation.

PC Board Layout

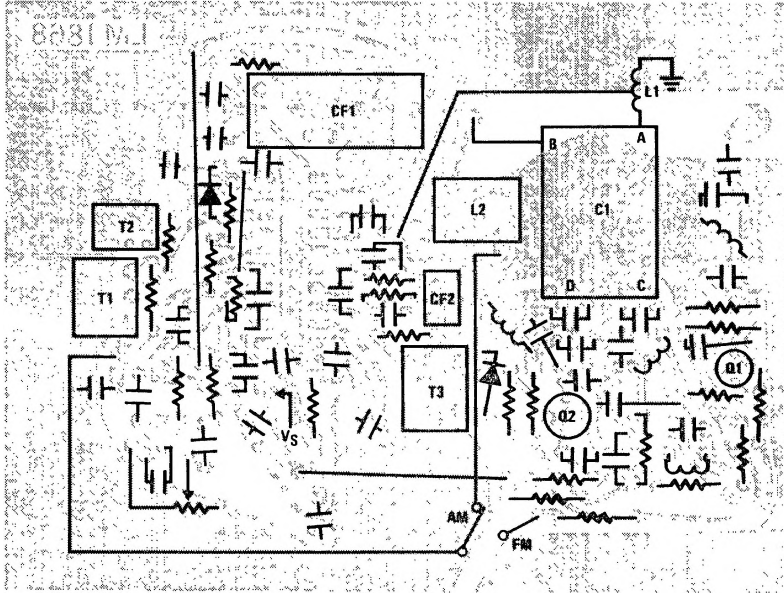

Component Side

TL/H/7909-6

Typical Performance Characteristics Typical Application

All curves are measured at audio output

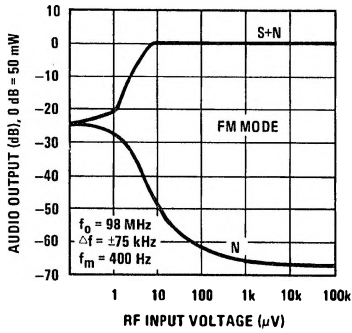

TL/H/7909-7

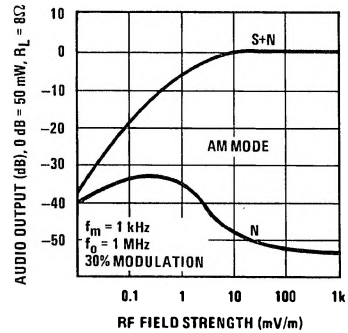

TL/H/7909-8

IC External Components (Application Circuit)

Component	Typical Value	Comments	Component	Typical Value	Comments
C1	100 pF	Removes tuner LO from IF input	R9	240k	} Set AGC time constant
C2	0.1 μF	Antenna coupling capacitor	C19	1 μF	
C4, C5	0.01 μF	FM IF decoupling capacitors	C7	10 μF	IF coupling
C6, C9	0.005 μF	} AM smoothing/FM de-emphasis network, de-emphasis pole is given by.	C8	0.1 μF	IF coupling
R5	1k		R10	5Ω	} High frequency load for audio amplifier, required to stabilize audio amplifier
$f1 \cong \frac{1}{2\pi (C6 + C9) \left(\frac{R4 R6}{R4 + R6} \right)}$			C21	250 μF	
C10	10 μF	Regulator decoupling capacitor	R1	6k2	Sets Q of quadrature coil, determining FM THD and recovered audio
C11	0.1 μF	Regulator decoupling capacitor	R2	12k	IF amplifier bias R
C12	10 μF	AC coupling to volume control	R3	5k6	Sets gain of AM IF and Q of AM IF output tank
C13	0.1 μF	Power supply decoupling	R4	10k	Detector load resistor
C14	50 μF	Power supply decoupling	R6	50k	Volume control
C15	0.1 μF	Audio amplifier input coupling	C18	0.02 μF	Power supply decoupling
R7	3k	} Roll off signals from detector in the AM band to prevent radiation	R11, R12	150Ω	Terminates the ceramic filter, biases FM IF input stage
C16	0,001 μF		D1	1N4148	Optional. Quickens the AGC response during turn on
C17	100 μF	Power amplifier feedback decoupling, sets low frequency supply rejection			
R8	16k	AM detector bias resistor			

Coil and Tuning Capacitor Specifications

- C1 AM ANT 140 pF max 5.0 pF min
AM OSC 82 pF max 5.0 pF min
Trimmers 5 pF
- L1 640 μH, Q_u = 200
R_p = 3k5 @ F = 796 kHz
(At secondary)
- L0, L2 360 μH, Q_u > 80 @ F = 796 kHz

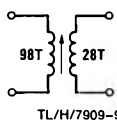

TL/H/7909-9

- L4 SWG # 20, N = 3 1/2 T, inner diameter = 5 mm
- L5 SWG # 20, N = 3 1/2 T, inner diameter = 5 mm
- L6 L = 0.44 μH, N = 4 1/2 T, Q_u = 70
- L7 SWG # 20, N = 2 1/2 T, inner diameter = 5 mm

- CF2 10.7 MHz ceramic filter
MURATA SFE 10.7 mA or equivalent
- Murata
2200 Lake Park Drive
Smyrna, GA 30080
(404) 436-1300

T1

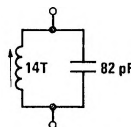

TL/H/7909-10

Q_u > 70 @ 10.7 MHz, L to resonate w/82 pF @ 10.7 MHz
TOKO KAC-K2318 or equivalent

T2

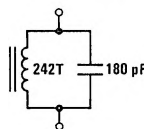

TL/H/7909-11

Q_u > 14 @ 455 kHz, L to resonate w/180 pF @ 455 kHz
TOKO 159GC-A3785 or equivalent

CF1

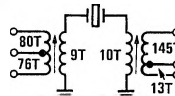

TL/H/7909-12

TOKO CFU-090D or equivalent
BW > 4.8 kHz @ 455 kHz

T3

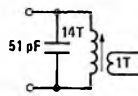

TL/H/7909-13

Apollo Electronics NS-107C or equivalent

Layout Considerations

AM SECTION

Most problems in an AM radio design are associated with radiation of undesired signals to the loopstick. Depending on the source, this radiation can cause a variety of problems including tweet, poor signal-to-noise, and low frequency oscillation (motor boating). Although the level of radiation from the LM1868 is low, the overall radio performance can be degraded by improper PCB layout. Listed below are layout considerations association with common problems.

- 1. Tweet:** Locate the loopstick as far as possible from detector components C6, C9, R4, and R5. Orient C6, C9, R4, and R5 parallel to the axis of the loopstick. Return R8, C6, C9, and C19 to a separate ground run (see Typical Application PCB).
- 2. Poor Signal-to-Noise/Low Frequency Oscillation:** Twist speaker leads. Orient R10 and C20 parallel to the axis of the loopstick. Locate C11 away from the loopstick.

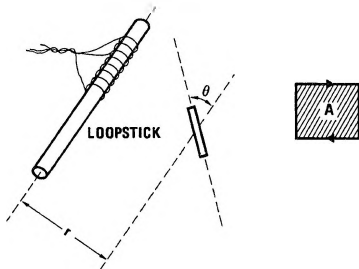

TL/H/7909-14

In general, radiation results from current flowing in a loop. In case 1 this current loop results from decoupling detector harmonics at pin 17; while in case 2, the current loop results from decoupling noise at the output of the audio amplifier and the output of the regulator. The level of radiation picked up by the loopstick is approximately proportional to: 1) $1/r^3$; where r is the distance from the center of the loopstick to the center of the current loop; 2) $\text{SIN } \theta$, where θ is the angle between the plane of the current loop and the axis of the loopstick; 3) I , the current flowing in the loop; and 4) A , the cross-sectional area of the current loop.

Pickup is kept low by short leads (low A), proper orientation ($\theta \approx 0$ so $\text{SIN } \theta \approx 0$), maximizing distance from sources to loopstick, and keeping current levels low.

FM SECTION

The pinout of the LM1868 has been chosen to minimize layout problems, however some care in layout is required to insure stability. The input source ground should return to C4 ground. Capacitors C13 and C18 form the return path for signal currents flowing in the quadrature coil. They should connect directly to the proper pins with short PC traces (see Typical Application PCB). The quadrature coil and input circuitry should be separated from each other as far as possible.

AUDIO AMPLIFIER

The standard layout considerations for audio amplifiers apply to the LM1868, that is: positive and negative inputs should be returned to the same ground point, and leads to the high frequency load should be kept short. In the case of the LM1868 this means returning the volume control ground (R6) to the same ground point as C17, and keeping the leads to C20 and R10 short.

Circuit Description (See Equivalent Schematic)

AM SECTION

The AM section consists of a mixer stage, a separate local oscillator, an IF gain block, an envelope detector, AGC circuits for controlling the IF and mixer gains, and a switching circuit which disables the AM section in the FM mode.

Signals from the antenna are AC-coupled into pin 7, the mixer input. This stage consists of a common-emitter amplifier driving a differential amp which is switched by the local oscillator. With no mixer AGC, the current in the mixer is $330 \mu\text{A}$; as the AGC is applied, the mixer current drops, decreasing the gain, and also the input impedance drops, reducing the signal at the input. The differential amp connected to pin 8 forms the local oscillator. Bias resistors are arranged to present a negative impedance at pin 8. The frequency of oscillation is determined by the tank circuit, the peak-to-peak amplitude is approximately $300 \mu\text{A}$ times the impedance at pin 8 in parallel with $8\text{k}\Omega$.

After passing through the ceramic filter, the IF signals are applied to the IF input. Signals at pin 11 are amplified by two AGC controlled common-emitter stages and then applied to the PNP output stage connected to pin 13. Biasing is arranged so that the current in the first two stages is set by the difference between a $250 \mu\text{A}$ current source and the Darlington device connected to pin 12.

When the AGC threshold is exceeded, the Darlington device turns ON, steering current away from the IF into ground, reducing the IF gain. Current in the IF is monitored by the mixer AGC circuit. When the current in the IF has dropped to $30 \mu\text{A}$, corresponding to 30 dB gain reduction in the IF, the mixer AGC line begins to draw current. This causes the mixer current and input impedance to drop, as previously described.

The IF output is level shifted and then peak detected at detector cap C1. By loading C1 with only the base current of the following device, detector currents are kept low. Drive from the AGC is taken at pin 14, while the AM detector output is summed with the FM detector output at pin 17.

FM SECTION

The FM section is composed of a 6-stage limiting IF driving a quadrature detector. The IF stages are identical with the exceptions of the input stage, which is run at higher current to reduce noise, and the last stage, which is switched OFF in the AM mode. The quadrature detector collectors drive a level shift arrangement which allows the detector output load to be connected to the regulated supply.

AUDIO AMPLIFIER

The audio amplifier has an internally set voltage gain of 120. The bandwidth of the audio amplifier is reduced in the AM mode so as to reduce the output noise falling in the AM band. The bandwidth reduction is accomplished by reducing the current in the input stage.

REGULATOR

A series pass regulator provides biasing for the AM and FM sections. Use of a PNP pass device allows the supply to drop to within a few hundred millivolts of the regulator output and still be in regulation.

