

LM18298 Dual Full-Bridge Driver

General Description

The LM18298 is a high voltage, high current dual full-bridge driver designed to accept standard TTL logic levels and drive inductive loads such as relays, solenoids, DC and stepping motors. Two enable inputs are provided to gate the input control signals.

The emitters of the lower transistors of each bridge are connected together and the corresponding external terminal can be used for the connection of a current sensing resistor. An additional supply input is provided to accommodate conventional logic supply voltages.

Features

- Power supply voltage up to 46V
- 2A output per channel
- Low saturation voltage
- Thermal shutdown protection
- Logical "0" input voltage up to 1.5V (High noise immunity)
- Pin for pin replacement for L298N

Applications

- DC and stepper motor drivers
- Relay and solenoid drivers

Block & Connection Diagrams

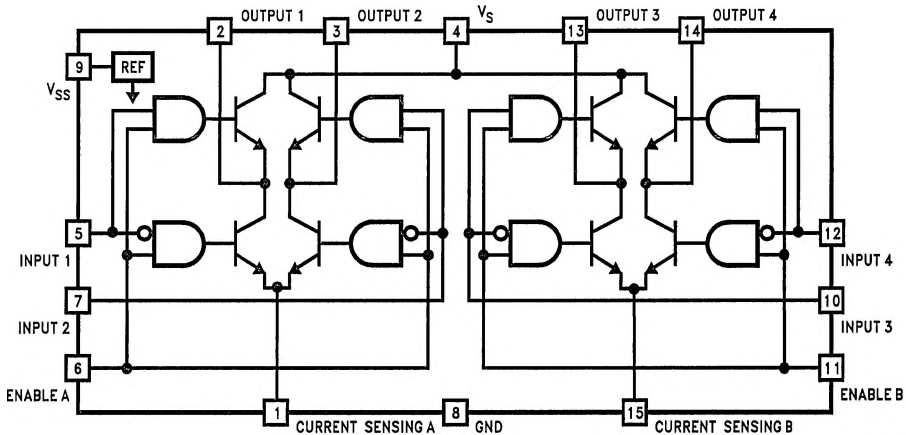

TL/H/8302-1

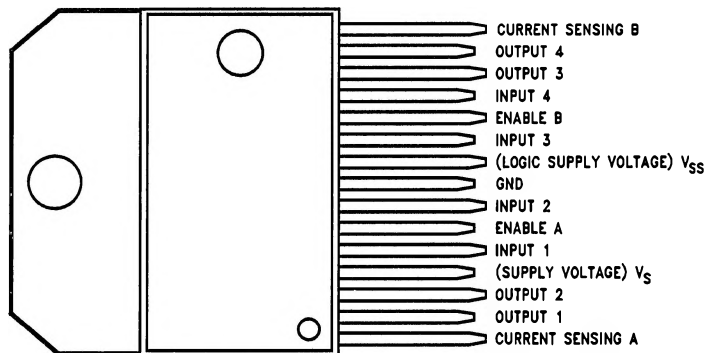

TL/H/8302-2

TO 220-15
Order Number LM18298T
NS Package Number TA15A

Absolute Maximum Ratings (Note 1)

If Military/Aerospace specified devices are required, please contact the National Semiconductor Sales Office/Distributors for availability and specifications.

Main Supply (Pin 4)	50V
Logic Supply (Pin 9)	7V
Logic Inputs (Pins 5, 6, 7, 10, 11, 12)	-0.3 to 7V
Peak Output Current (Per Channel)	
Non-Repetitive ($t = 100 \mu\text{s}$)	3A
Repetitive (80% duty cycle, $t_{\text{ON}} = 10 \text{ ms}$)	2.5A
DC Operation	2A

Sense Voltage (Pins 1, 15)	-1 to +2.3V
Power Dissipation (Note 2)	25W
ESD Susceptibility (Note 3)	1 kV
Lead Temperature (Soldering, 10 seconds)	260°C
Storage Temperature Range	-65°C to +150°C

Operating Ratings

Junction Temperature Range (T_J)	-40°C to +150°C
Main Supply (Pin 4)	46V

Electrical Characteristics

$V_S = 42\text{V}$, $V_{SS} = 5\text{V}$, $I_O = 0\text{A}$, $T_J = 25^\circ\text{C}$, $L = 0\text{V}$, $H = 5\text{V}$, unless otherwise specified

Symbol	Parameter	Conditions	Typical (Note 4)	Limit (Note 5)	Units (Limits)
V_S	Main Supply Voltage (Pin 4)			$V_{SS} + 2.5$	V (min)
				46	V (max)
V_{SS}	Logic Supply Voltage (Pin 9)			4.5	V (min)
				7	V (max)
I_S	Main Supply Quiescent Current (Pin 4)	Enable = H, Input = L	9	22	mA (max)
		Enable = H, Input = H	32	70	
		Enable = L, Input = X		4	
I_{SS}	Logic Supply Quiescent Current (Pin 9)	Enable = H, Input = L	22	36	mA (max)
		Enable = H, Input = H	6	12	
		Enable = L, Input = X		6	
V_{IL}	Low Level Input Voltage (Pins 5, 7, 10, 12)			-0.3	V (min)
				1.5	V (max)
V_{IH}	High Level Input Voltage (Pins 5, 7, 10, 12)			2.3	V (min)
				V_{SS}	V (max)
I_{IL}	Low Level Input Current (Pins 5, 7, 10, 12)	Input = L		-10	μA (max)
I_{IH}	High Level Input Current (Pins 5, 7, 10, 12)	Input = H	30	100	μA (max)
V_{ENL}	Low Level Enable Voltage (Pins 6, 11)			-0.3	V (min)
				1.5	V (max)
V_{ENH}	High Level Enable Voltage (Pins 6, 11)			2.3	V (min)
				V_{SS}	V (max)
I_{ENL}	Low Level Enable Input Current (Pins 6, 11)	Enable = L		-10	μA (max)
I_{ENH}	High Level Enable Input Current (Pins 6, 11)	Enable = H	30	100	μA (max)

Electrical Characteristics (Continued)
 $V_S = 42V$, $V_{SS} = 5V$, $I_O = 0A$, $T_J = 25^\circ C$, unless otherwise specified

Symbol	Parameter	Conditions	Typical (Note 4)	Limit (Note 5)	Units (Limits)
$V_{CE\ sat\ (H)}$	Source Saturation Voltage (Pins 2, 3, 13, 14)	$I_O = 1A$	1.35	1.7	V (max)
		$I_O = 2A$	2.0	2.7	
$V_{CE\ sat\ (L)}$	Sink Saturation Voltage (Pins 2, 3, 13, 14)	$I_O = 1A$	1.2	1.6	V (max)
		$I_O = 2A$	1.7	2.3	
$V_{CE\ sat}$	Total Drop $V_{CE\ sat\ (H)} + V_{CE\ sat\ (L)}$	$I_O = 1A$		3.2	V (max)
		$I_O = 2A$		4.9	
V_{sense}	Sensing Voltage (Pins 1, 15)	$t \leq 50\ \mu s$		-1	V (min)
		Continuous		-0.5	
		Continuous		2	V (max)
T_1	Source Current Turn-Off Delay	0.5 Input to 0.9 I_O (Figure 2)	0.5		μs
T_2	Source Current Fall Time	0.9 I_O to 0.1 I_O (Figure 2)	0.15		μs
T_3	Source Current Turn-On Delay	0.5 Input to 0.1 I_O (Figure 2)	1.3		μs
T_4	Source Current Rise Time	0.1 I_O to 0.9 I_O (Figure 2)	0.85		μs
T_5	Sink Current Turn-Off Delay	0.5 Input to 0.9 I_O (Figure 3)	0.25		μs
T_6	Sink Current Fall Time	0.9 I_O to 0.1 I_O (Figure 3)	0.1		μs
T_7	Sink Current Turn-On Delay	0.5 Input to 0.1 I_O (Figure 3)	1.3		μs
T_8	Sink Current Rise Time	0.1 I_O to 0.9 I_O (Figure 3)	0.1		μs
f_C	Commutation Frequency	$I_O = 2A$	25		kHz

Note 1: Absolute Maximum Ratings indicate limits beyond which damage to the device may occur. DC and AC electrical specifications do not apply when operating the device beyond its specified **Operating Ratings**.

Note 2: The maximum power dissipation must be derated at elevated temperatures and is a function of $T_{J\ max}$, θ_{JC} , and T_C . The maximum allowable power dissipation at any temperature is $P_{D\ max} = (T_{J\ max} - T_C)/\theta_{JC}$ or the number given in the **Absolute Maximum Ratings**, whichever is lower. The typical junction-to-case thermal resistance (θ_{JC}) of the LM18298 is $3^\circ C/W$.

Note 3: Human body model, 100 pF discharged through a 1.5 k Ω resistor.

Note 4: Typicals are at $25^\circ C$ and represent the most likely parametric norm.

Note 5: Limits are guaranteed and 100% tested.

Typical Performance Characteristics

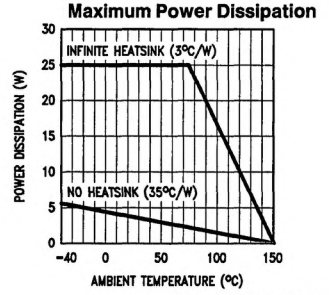
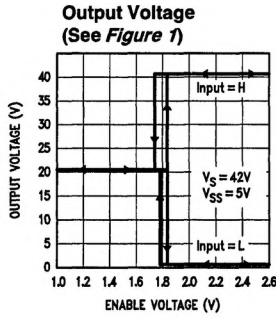
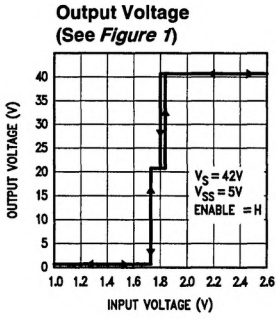

TL/H/9302-3

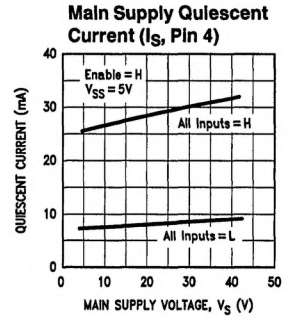
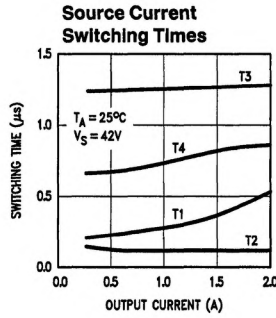
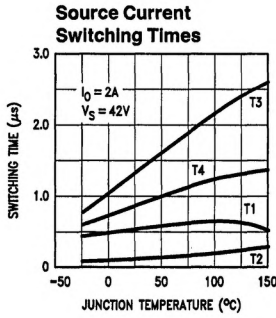

TL/H/9302-12

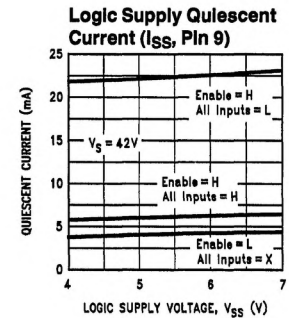
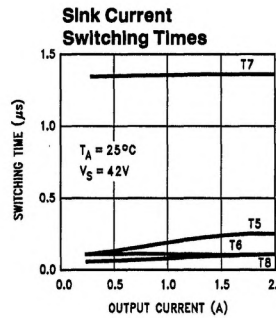
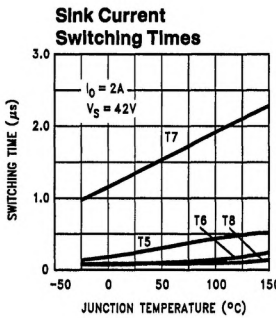

TL/H/9302-13

Test Circuits

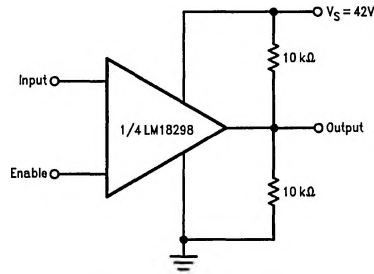

TL/H/9302-4

FIGURE 1. Input/Enable Threshold Test Circuit

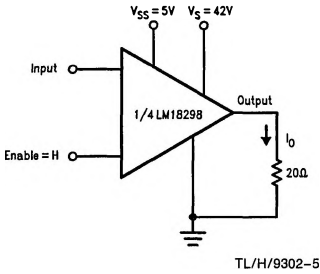

TL/H/9302-5

FIGURE 2(a). Source Current Switching Time Test Circuit

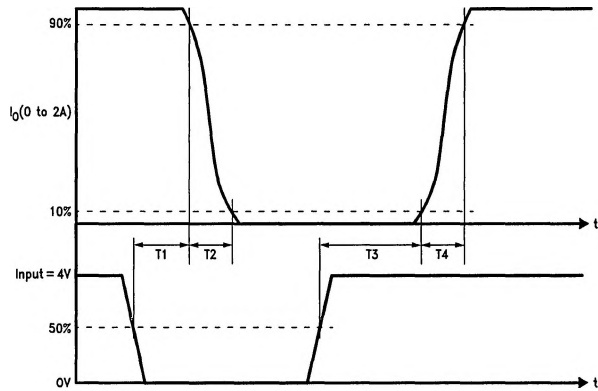

TL/H/9302-6

FIGURE 2(b). Source Current Switching Time Definitions

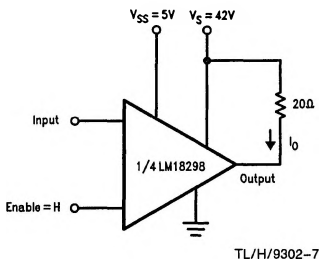

TL/H/9302-7

FIGURE 3(a). Sink Current Switching Time Test Circuit

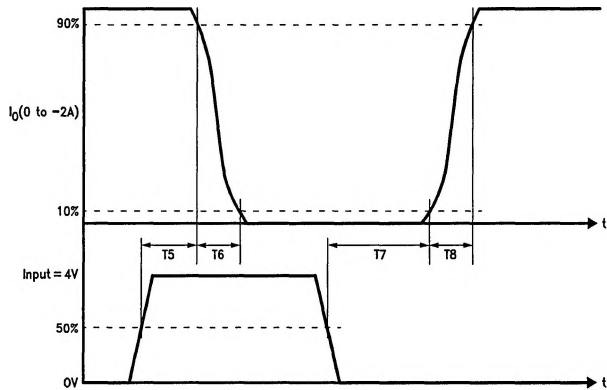

TL/H/9302-8

FIGURE 3(b). Sink Current Switching Time Definitions

Applications Information

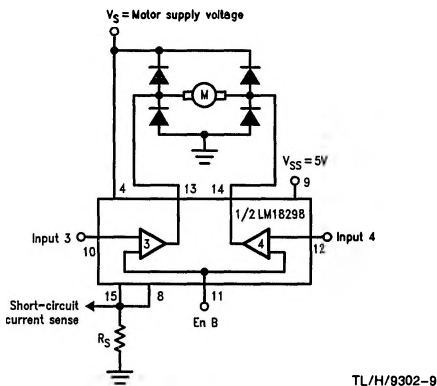

TL/H/9302-9

Enable B	Inputs	Motor Direction
H	Input 3 = H, Input 4 = L	Clockwise
	Input 3 = L, Input 4 = H	Counterclockwise
	Input 3 = Input 4	Dynamic Braking
L	Input 3 = X, Input 4 = Input 3	Coast to a Stop

L = Low H = High X = don't care
FIGURE 4. Bidirectional DC Motor Control

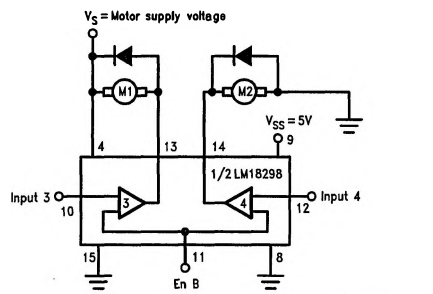

TL/H/9302-10

Enable B	Input 3	Motor 1	Input 4	Motor 2
H	H	Dynamic Braking	H	Run
H	L	Run	L	Dynamic Braking
L	X	Coast to a Stop	X	Coast to a Stop

L = Low H = High X = Don't Care
FIGURE 5. 2-Motor Controller (Using both High- and Low-Side Driver Modes)

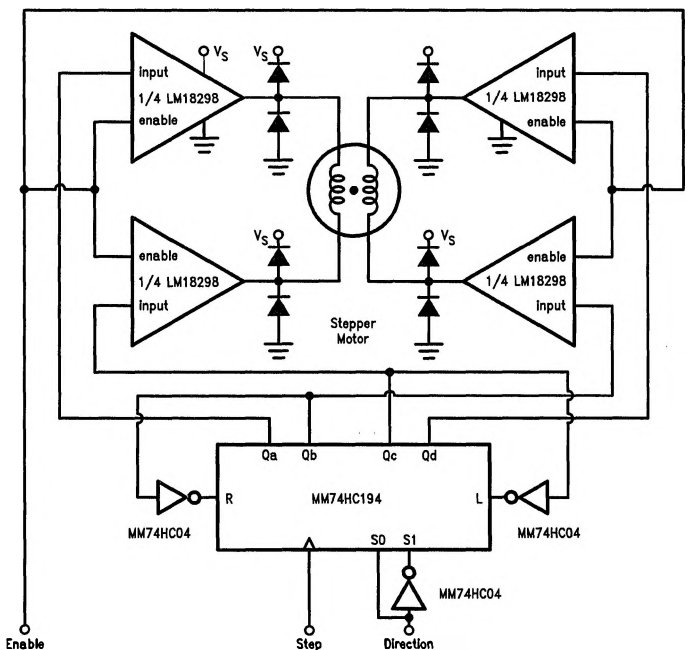

FIGURE 6. Two-Phase Bipolar Stepper Motor Control Circuit

TL/H/9302-11

CLAMP DIODES

When driving inductive loads, diodes are necessary to clamp spikes at the LM18298 outputs. Clamp diodes must have a recovery time of 200 ns or better and a forward drop

of 1.2V or less at the rated load current. Typical devices are the MB346 (Microsemi Corp., Santa Ana, CA), and the V331X (Varo Semiconductor Inc., Garland, TX).