

# LM1801 Battery Operated Power Comparator

## General Description

The LM1801 is an extremely low power comparator with a high current, open-collector output stage. The typical supply current is only  $7 \mu\text{A}$ , yet in its switched state the comparator can source or sink  $0.5\text{A}$ . The LM1801 is designed to operate in a standby mode for 1 year, powered by a 9V alkaline battery. Provision is made for operation from supplies of up to 14V. An internal  $14.5\text{V}$  zener clamp may be used for supply regulation in line operated applications.

The low battery detector and stand-by current drain are externally programmed by resistors. A parallel output is provided to "OR" as many as 9 comparators, and a feedback pin allows adding hysteresis or latching functions. Two on-chip voltage sources can serve as bias points for the comparator inputs or as references for other circuit functions.

## Features

- 8V to 14V operation
- Direct drive to horn
- Internal zener for supply regulation
- Parallel comparator capability
- Extremely low stand-by current drain
- 2 references on chip
- Low battery detector
- $0.5\text{A}$  output transistor
- Output clamp diodes on chip

## Applications

- Intrusion alarms
- Water leak detectors
- Gas leak detectors
- Overvoltage crowbars
- Battery operated monitors

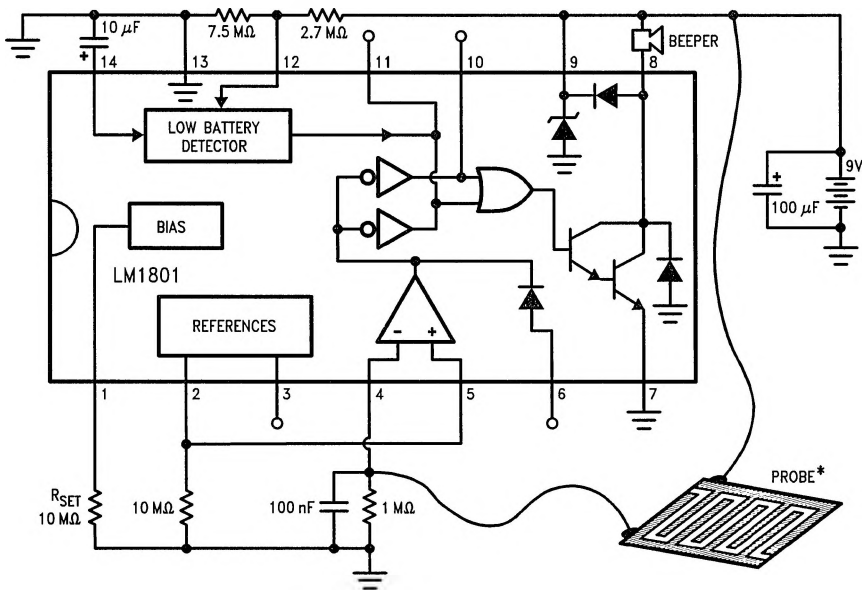

TL/H/9139-1

\*Alarm sounds when probe conductors are bridged with water droplets. A suitable probe can be etched in copper clad board.

**FIGURE 1. Water Leak Detector**

Order Number LM1801N  
See NS Package Number N14A

## Absolute Maximum Ratings

If Military/Aerospace specified devices are required, contact the National Semiconductor Sales Office/Distributors for availability and specifications.

Supply Voltage	14V
Input Voltage	-0.3V to 14V
Input Differential Voltage	± 14V

Power Dissipation (Note 1)	1176 mW
Operating Temperature Range	0°C to +70°C
Storage Temperature Range	-65°C to +125°C
Lead Temperature (Soldering, 10 sec.)	260°C
ESD rating to be determined.	

## Electrical Characteristics (Note 2)

Parameter	Conditions	Min	Typ	Max	Units
<b>Comparator</b>					
Input Offset Voltage			5	15	mV
Input Bias Current			2	10	nA
Input Offset Current			0.5	8	nA
Pin 6 Output Low	$I_{SINK} = 100 \mu A$		1.5		V
<b>Output Stage (Pin 8)</b>					
Leakage Current			5	100	nA
Saturation Voltage	$I_B = 200 \text{ mA}$		0.7	1.3	V
Saturation Voltage	$I_B = 500 \text{ mA}$		1.9		V
<b>Common Alarm Line (Pin 10)</b>					
Drive Capabilities					
Output Voltage High	$V_4 > V_5$		6.8		V
Output Current	$V_{10} = 0.0V$		6.5		mA
Driver Requirements					
Input Voltage	$V_5 > V_4$		3.6		V
Input Current	$V_8 = 1.5V, I_B = 200 \text{ mA}$		0.4		mA
<b>Regulator</b>					
Pin 2 Reference Voltage			5.8		V
Temperature Coefficient			5		mV/°C
Pin 3 Reference Voltage			5.2		V
Temperature Coefficient			7		mV/°C
<b>Battery Check Oscillator</b>					
Threshold Voltage (Pin 12)		5.5	6.0	6.5	V
Period	$V^+ = 7.5V, C_1 = 10 \mu F$		40	50	s
Beep Pulse Width	$V^+ = 7.5V, C_1 = 10 \mu F$		60		ms
Supply Current (Note 3)			6	8	$\mu A$
Zener Clamp Voltage, V9	$I_B = 1 \text{ mA}$		14.5		V

**Note 1:** For operating at elevated temperatures, the device must be derated based on a 125°C maximum junction temperature and a thermal resistance of 85°C/W junction to ambient.

**Note 2:**  $R_{SET} = 10 \text{ M}\Omega$ ,  $V^+ = 9V$ ,  $T_A = 25^\circ\text{C}$ , (Figure 1).

**Note 3:** Output OFF.

TL/H/9139-2

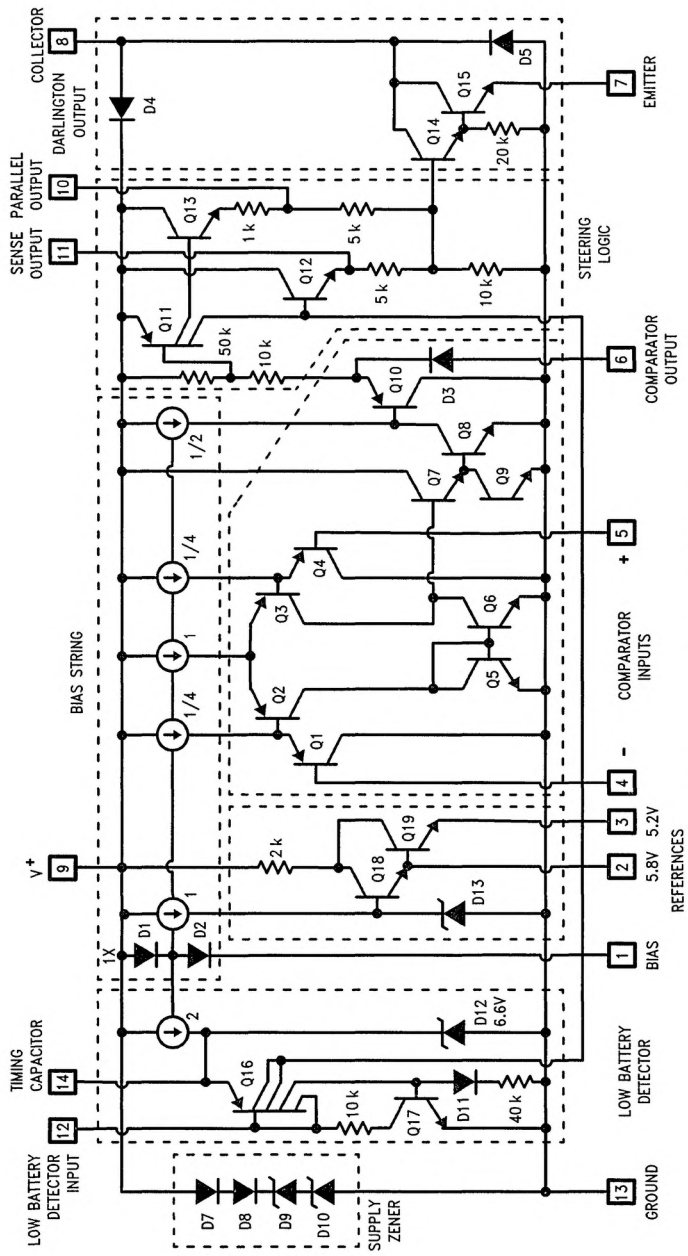

FIGURE 2. LM1801 Internal Schematic

## Applications Hints

### CIRCUIT OPERATION

The LM1801 includes a bias string, comparator, steering logic, output transistor, supply clamp, low voltage detector, and reference. An internal schematic is shown in *Figure 2*.

The chip is biased by a group of current sources that are controlled externally by a fixed resistor,  $R_{Set}$ . In normal, or standby operation the supply current drain is nominally 6 times the set current at pin 1. The voltage at pin 1 is two forward diode potentials ( $D1 + D2 = 1.2V$  typical) less than the positive supply voltage. Practical values of  $R_{Set}$  range from 100 k $\Omega$  to 10 M $\Omega$ . Higher currents are useful where speed is important, while lower currents promote long battery life.

The total standby current drain of the LM1801 will include, in addition to the above, the current drawn by the external circuits connected at pins 2, 3, and 12. These are the resistive dividers used to set the low battery threshold and comparator threshold.

The voltage comparator consists of devices Q1 through Q10. The input features a common mode range from less than 300 mV to  $V^+ - 1.2V$ . If the non-inverting input is within this range, the output state remains valid for inverting inputs of 0V to  $V^+$ . If the inverting input is within the common mode range, valid comparisons hold for non-inverting inputs of 300 mV to  $V^+$ . The comparator may not switch low if the positive input is grounded.

With a set resistance of 10 M $\Omega$ , comparator input bias currents of 2 nA are typical. This allows the use of high-value resistors (10 M $\Omega$ ) at the comparator inputs which help minimize total supply current. The comparator's output is available through a steering diode (D3) for latching or hysteresis functions.

The comparator output is also coupled internally to the steering logic (Q11–Q13). The comparator, low battery detector, and parallel output (pin 10) functions are OR'd in the logic circuit. In addition, the comparator output is steered to the parallel output. If the parallel outputs (pin 10) of two or more chips are wired together along with a common ground, the comparator on any one chip can cause all of the other output stages to switch, as well as its own output. Outputs are switched when the inverting comparator input is positive with respect to the non-inverting input. Low battery functions are coupled to the steering logic via Q12, and therefore do not affect the parallel output (Q13).

If the sense outputs (pin 11) of two or more chips are wired together, the comparator and low battery detector will cause all outputs to switch.

The output transistor is a 0.5A Darlington. Included in this structure are two clamp diodes. D4 clamps positive collector voltage excursions to the supply, and D5 clamps negative excursions to ground.

The output transistor is normally operated with the emitter grounded. Under these conditions the collector is guaranteed to saturate no higher than 1.3V at 200 mA. 1.9V saturation voltage is typical at 500 mA. The emitter may also be used as an output, and it can swing from ground potential up to 5V on a 9V supply. Emitter swing in the positive direction is limited in the parallel output mode.

A low battery detector with a 6V threshold is also included on chip. This circuit consists of Q16, Q17, D11, and D12. When pin 12, the battery sense input, is higher than 6V, D12 clamps the emitter of Q16 to 6.6V, and the output from the current source flows through the zener to ground. If pin 14 drops below 6V, Q16 is biased ON, and current is drawn away from the zener and into Q16. The SCR formed by Q16 and Q17 is triggered when Q16 is biased ON. The capacitor at pin 14 is discharged, part of its charge flows to the steering logic to pulse the output transistor, and the remainder holds the SCR in its ON state.

When the timing capacitor has discharged, conduction in Q16 and Q17 is commutated. Note that the output from the current source is less than the sustaining current required by the SCR. The current source slowly charges the capacitor until the voltage across it rises 0.6V above pin 12, where the cycle repeats itself. If pin 12 rises above 6V, the zener clamps the voltage at pin 14 and the low battery detector remains OFF.

Pin 12 is biased from an external resistive divider. The divider should be designed to detect at no lower than  $V^+ = 7V$ . The detector will continue to work at lower voltages providing pin 12 is at least 1V below the supply. For a 9V alkaline battery a threshold of 8.2V is common. A resistive divider of 2.7 M $\Omega$  and 7.5 M $\Omega$  provides the appropriate threshold.

In many applications the on-chip references can provide bias points. The references are driven from D13, and buffered by Q18 and Q19. If only one bias point is needed the first reference (pin 2) should be used, and the unused output (pin 3) may be left open. The tiny leakage currents in Q18 can cause Q19 (pin 3) to drift upward if a 10 M $\Omega$  load resistor is not included at pin 2. The combined output current from pins 2 and 3 should not exceed 1 mA. If neither reference output is used, pins 2 and 3 should be left open.

The last section of the LM1801 is the supply zener. It is built from a series combination of two diodes and two zeners. The breakdown voltage at 1 mA is 14.5V, and the series resistance is about 200 $\Omega$ . In line operated applications the zener may be used for supply regulation or transient protection. The zener is designed to carry up to 10 mA.

## Applications Hints (Continued)

### DESIGN HINTS

If the comparator inputs are subjected to electrostatic discharges (ESD), a series resistance is recommended to provide protection. Given the low input bias currents, 100 k $\Omega$  resistors can be added without affecting circuit performance, yet they greatly enhance static protection. The LM1801 is not designed to withstand reverse battery.

With a 10 M $\Omega$   $R_{set}$ , the LM1801 responds to an input in approximately 2.5  $\mu$ s, and turns OFF in 200  $\mu$ s. Higher set currents decrease the response time. With  $R_{set} = 1$  M $\Omega$ , the output switches low in 0.5  $\mu$ s, and high in 50  $\mu$ s, and with  $R_{set} = 100$  k $\Omega$ , the response times are reduced to 0.2  $\mu$ s and 12  $\mu$ s.

When the circuit is in the standby state ( $V_5 > V_4$ ), the current consumption in a typical application such as *Figure 1* is less than approximately 7  $\mu$ A. However, when the comparator switches LOW ( $V_4 > V_5$ ), the supply current increases to 3 mA owing to the Darlington base current. Therefore, to realize maximum battery life, any application should be devised so that  $V_5 > V_4$  in the standby or resting state.

The output stage can drive lamps, LEDs, buzzers, beepers, relays, motors, and solenoids. However, the low battery detector is not compatible with every load. Since the low battery detector generates only a short pulse (60 ms typical), it is intended for use with buzzers and beepers. Depending on the response time and resonant frequency, some buzzers may only produce a single click. Self-oscillating beepers usually start instantly and produce a recognizable "tweet" when a low battery condition is detected. Incandescent lamps, large relays and solenoids will do absolutely nothing when pulsed by the low battery detector.

Self-oscillating beepers are readily available, such as the Sonalert SNP428 and the Panasonic EAL-069A. These units are guaranteed to self-start when power is applied.

To defeat the low battery detector, short pins 12 and 14 together, and do not connect them to anything else.

Circuit board assembly procedures should include a thorough cleaning to remove flux and other residues. The input pins are often biased by very high impedance sources and even a 10 M $\Omega$  leakage path can upset circuit operation.

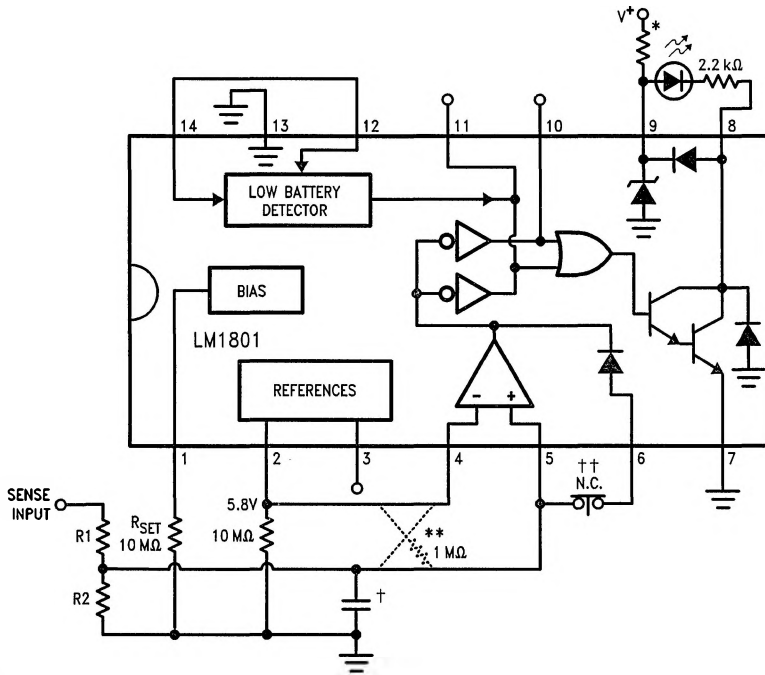

TL/H/9139-3

$$R_1 + R_2 = 10 \text{ M}\Omega$$

$$V_{TRIP} = \left( \frac{R_1 + R_2}{R_2} \right) 5.8 \text{ V}$$

Minimum trip voltage = 5.8V

\*Use series resistor for supplies > 14V. Select for  $I_{ZENER} = 5$  mA.

\*\*Reverse connections and add 1 M $\Omega$  resistor for overvoltage indication.

†Optional filter capacitor, 1 nF to 100 nF.

††Push to reset. Eliminate pin 6 connection for non-latching operation.

FIGURE 3. Under (Over) Voltage Indicator

Applications Hints (Continued)

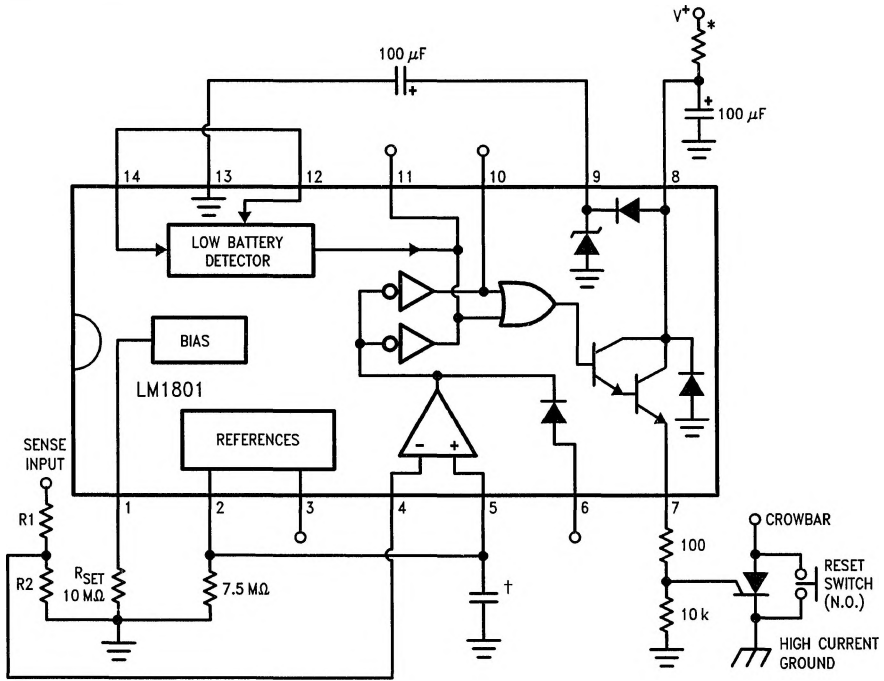

TL/H/9139-4

$R_1 + R_2 = 10 \text{ M}\Omega$

$V_{\text{TRIP}} = \left( \frac{R_1 + R_2}{R_2} \right) 5.8\text{V}$

\*Use series resistor for supplies > 14V.

†Optional filter capacitor, 1 nF to 100 nF.

FIGURE 4. Overvoltage Crowbar

## Applications Hints (Continued)

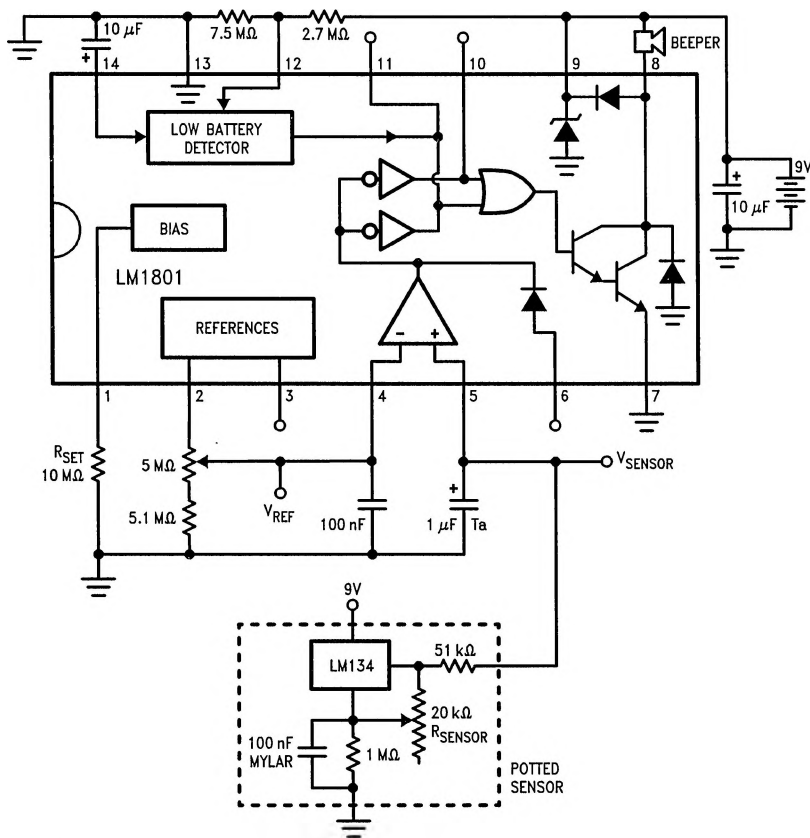

TL/H/9139-5

To set trip point, trim  $V_{REF}$  to 4.5V. Trim  $R_{SENSOR}$  at room temperature (23°C) for:

$$V_{SENSOR} = 4.5 \left( \frac{273 + 23}{T_X + 273} \right)$$

where  $T_X$  is the desired trip point temperature in °C. As shown, the alarm is activated for over temperature conditions. Reverse the comparator connections for under temperature alarm. The 20 kΩ potentiometer allows an adjustment range of -55°C to +60°C. Add a 10k fixed resistance in series with the potentiometer for a +50°C to +125°C adjustment range.  $R_{SENSOR}$  can be replaced by a fixed resistor once the desired value is found.  $V_{REF}$  is used as a final adjustment.

**FIGURE 5. Over (Under) Temperature Alarm**

Applications Hints (Continued)

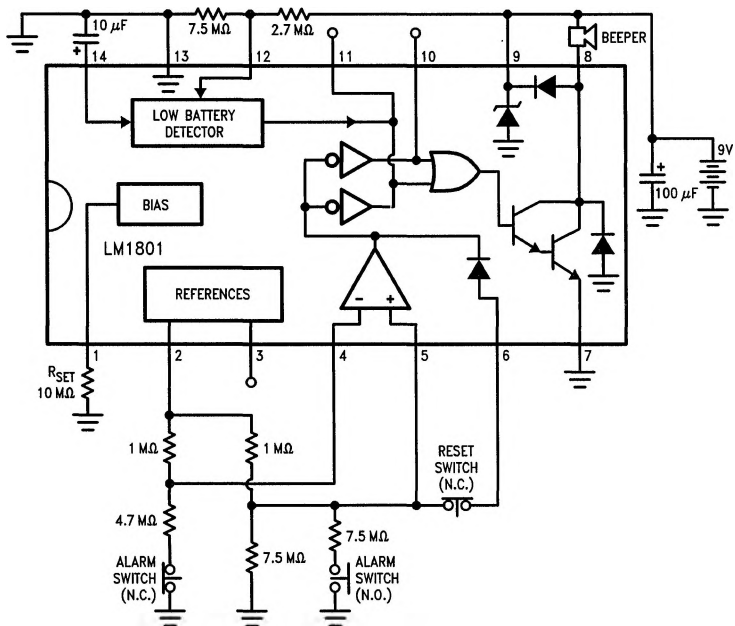

FIGURE 6. Simple Alarm Circuit

TL/H/9139-6

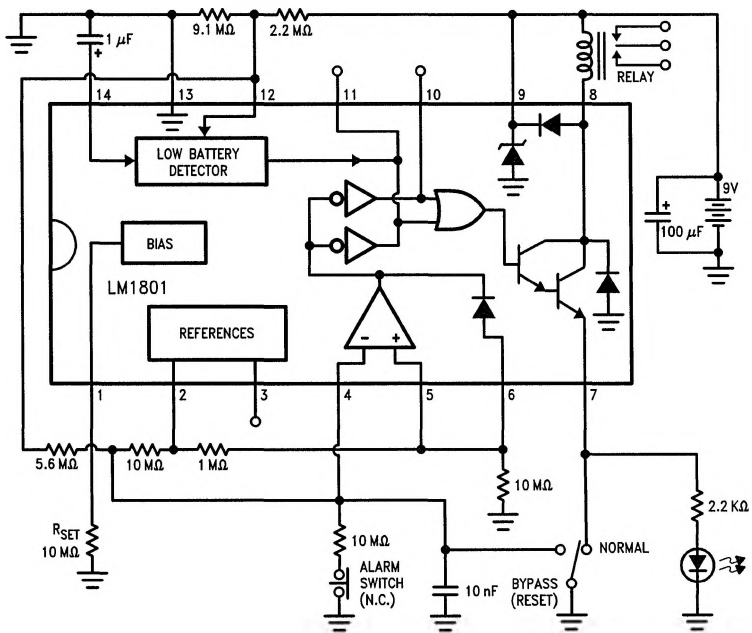

FIGURE 7. Full-Featured Intrusion Alarm

TL/H/9139-7