



LM158/LM258/LM358, LM158A/LM258A/LM358A, LM2904 Low Power Dual Operational Amplifiers

General Description

The LM158 series consists of two independent, high gain, internally frequency compensated operational amplifiers which were designed specifically to operate from a single power supply over a wide range of voltages. Operation from split power supplies is also possible and the low power supply current drain is independent of the magnitude of the power supply voltage.

Application areas include transducer amplifiers, dc gain blocks and all the conventional op amp circuits which now can be more easily implemented in single power supply systems. For example, the LM158 series can be directly operated off of the standard +5 V_{DC} power supply voltage which is used in digital systems and will easily provide the required interface electronics without requiring the additional ±15 V_{DC} power supplies.

Unique Characteristics

- In the linear mode the input common-mode voltage range includes ground and the output voltage can also swing to ground, even though operated from only a single power supply voltage.
- The unity gain cross frequency is temperature compensated.
- The input bias current is also temperature compensated.

Advantages

- Eliminates need for dual supplies
- Two internally compensated op amps in a single package

- Allows directly sensing near GND and V_{OUT} also goes to GND
- Compatible with all forms of logic
- Power drain suitable for battery operation
- Pin-out same as LM1558/LM1458 dual operational amplifier

Features

- Internally frequency compensated for unity gain
- Large dc voltage gain 100 dB
- Wide bandwidth (unity gain) (temperature compensated) 1 MHz
- Wide power supply range:
 - Single supply 3 V_{DC} to 32 V_{DC}
 - or dual supplies ±1.5 V_{DC} to ±16 V_{DC}
- Very low supply current drain (500 μA)—essentially independent of supply voltage
- Low input biasing current (temperature compensated) 45 nA_{DC}
- Low input offset voltage and offset current 2 mV_{DC} 5 nA_{DC}
- Input common-mode voltage range includes ground
- Differential input voltage range equal to the power supply voltage
- Large output voltage swing 0 V_{DC} to V⁺ - 1.5 V_{DC}

Connection Diagrams (Top Views)

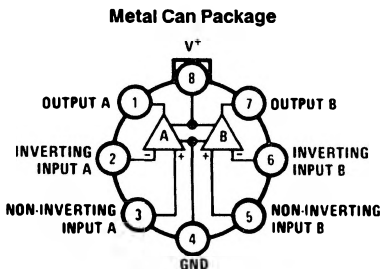

TL/H/7787-1

Order Number LM158AH, LM158H, LM258AH, LM258H, LM358AH or LM358H
See NS Package Number H08C

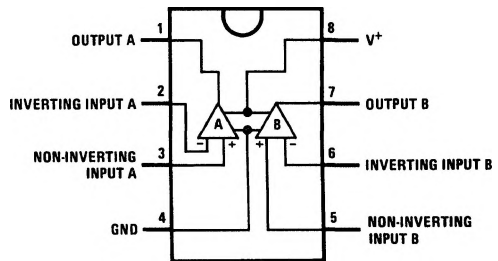

TL/H/7787-2

Order Number LM158J, LM158AJ or LM358J
See NS Package Number J08A
Order Number LM358M, LM358AM or LM2904M
See NS Package Number M08A
Order Number LM358AN, LM358N or LM2904N
See NS Package Number N08E

Absolute Maximum Ratings

If Military/Aerospace specified devices are required, please contact the National Semiconductor Sales Office/Distributors for availability and specifications. (Note 9)

	LM158/LM258/LM358 LM158A/LM258A/LM358A	LM2904	LM158/LM258/LM358 LM158A/LM258A/LM358A	LM2904	LM158/LM258/LM358 LM158A/LM258A/LM358A
Supply Voltage, V^+	32 V _{DC} or ± 16 V _{DC}	26 V _{DC} or ± 13 V _{DC}	0°C to +70°C	–40°C to +85°C	–40°C to +85°C
Differential Input Voltage	32 V _{DC}	26 V _{DC}	–25°C to +85°C	–55°C to +125°C	–55°C to +125°C
Input Voltage	–0.3 V _{DC} to +32 V _{DC}	–0.3 V _{DC} to +26 V _{DC}	–65°C to +150°C	–65°C to +150°C	–65°C to +150°C
Power Dissipation (Note 1)	830 mW	830 mW	260°C	260°C	260°C
Molded DIP (LM358N)	550 mW	530 mW	300°C	300°C	300°C
Metal Can (LM158H/ LM258H/LM358H)	530 mW	530 mW	260°C	260°C	260°C
Small Outline Package	Continuous	Continuous	215°C	215°C	215°C
Output Short-Circuit to GND (One Amplifier) (Note 2)	50 mA	50 mA	220°C	220°C	220°C
$V^+ \leq 15$ V _{DC} and $T_A = 25^\circ\text{C}$			See AN-450 "Surface Mounting Methods and Their Effect on Product Reliability" for other methods of soldering surface mount devices.		
Input Current ($V_{IN} < -0.3$ V _{DC}) (Note 3)			ESD Tolerance (Note 10)	250V	250V

Electrical Characteristics $V^+ = +5.0$ V_{DC}, unless otherwise stated

Parameter	Conditions	LM158A		LM258A		LM358A		LM158/LM258		LM358		LM2904		Units
		Min	Typ	Max	Min	Typ	Max	Min	Typ	Max	Min	Typ	Max	
Input Offset Voltage	(Note 5), $T_A = 25^\circ\text{C}$	± 1	± 2	± 1	± 3	± 2	± 3	± 2	± 5	± 2	± 7	± 2	± 7	mV _{DC}
Input Bias Current	$I_{IN(+)}$ or $I_{IN(-)}$, $T_A = 25^\circ\text{C}$, $V_{CM} = 0\text{V}$, (Note 6)	20	50	40	80	45	100	45	150	45	250	45	250	nA _{DC}
Input Offset Current	$I_{IN(+)} - I_{IN(-)}$, $V_{CM} = 0\text{V}$, $T_A = 25^\circ\text{C}$	± 2	± 10	± 2	± 15	± 5	± 30	± 5	± 30	± 5	± 50	± 5	± 50	nA _{DC}
Input Common-Mode Voltage Range	$V^+ = 30$ V _{DC} ; (Note 7) (LM2904, $V^+ = 26\text{V}$), $T_A = 25^\circ\text{C}$	0	$V^+ - 1.5$	0	$V^+ - 1.5$	0	$V^+ - 1.5$	0	$V^+ - 1.5$	0	$V^+ - 1.5$	0	$V^+ - 1.5$	V _{DC}
Supply Current	Over Full Temperature Range $R_L = \infty$ on All Op Amps $V^+ = 30\text{V}$ (LM2904 $V^+ = 26\text{V}$) $V^+ = 5\text{V}$	1	2	1	2	1	2	1	2	1	2	1	2	mA _{DC}
		0.5	1.2	0.5	1.2	0.5	1.2	0.5	1.2	0.5	1.2	0.5	1.2	mA _{DC}

Electrical Characteristics (Continued) $V^+ = +5.0$ V_{DC}. Note 4, unless otherwise stated

Parameter	Conditions	LM158A		LM258A		LM358A		LM158/LM258		LM358		LM2904		Units
		Min	Typ	Max	Min	Typ	Max	Min	Typ	Max	Min	Typ	Max	
Large Signal Voltage Gain	$V^+ = 15$ V _{DC} , $T_A = 25^\circ\text{C}$, $R_L \geq 2$ k Ω , (For $V_O = 1$ V _{DC} to 11 V _{DC})	50	100	50	100	25	100	25	100	25	100	25	100	V/mV
Common-Mode Rejection Ratio	DC, $T_A = 25^\circ\text{C}$, $V_{CM} = 0$ V to $V^+ - 1.5$ V _{DC}	70	85	70	85	65	85	85	85	65	85	50	70	dB
Power Supply Rejection Ratio	DC, $V^+ = 5$ V _{DC} to 30 V _{DC} (LM2904, $V^+ = 5$ V _{DC} to 26 V _{DC}), $T_A = 25^\circ\text{C}$	65	100	65	100	65	100	65	100	65	100	50	100	dB
Amplifier-to-Amplifier Coupling	$f = 1$ kHz to 20 kHz, $T_A = 25^\circ\text{C}$ (Input Referred), (Note 8)	-120		-120		-120		-120		-120		-120		dB
Output Current Source	$V_{IN}^+ = 1$ V _{DC} ; $V_{IN}^- = 0$ V _{DC} ; $V^+ = 15$ V _{DC} ; $V_O = 2$ V _{DC} , $T_A = 25^\circ\text{C}$	20	40	20	40	20	40	20	40	20	40	20	40	mA _{DC}
Sink	$V_{IN}^- = 1$ V _{DC} , $V_{IN}^+ = 0$ V _{DC} $V^+ = 15$ V _{DC} , $T_A = 25^\circ\text{C}$, $V_O = 2$ V _{DC}	10	20	10	20	10	20	10	20	10	20	10	20	mA _{DC}
	$V_{IN}^- = 1$ V _{DC} ; $V_{IN}^+ = 0$ V _{DC} $T_A = 25^\circ\text{C}$, $V_O = 200$ mV _{DC} , $V^+ = 15$ V _{DC}	12	50	12	50	12	50	12	50	12	50	12	50	μ A _{DC}
Short Circuit to Ground	$T_A = 25^\circ\text{C}$, (Note 2), $V^+ = 15$ V _{DC}	40	60	40	60	40	60	40	60	40	60	40	60	mA _{DC}
Input Offset Voltage	(Note 5)	± 4		± 4		± 5		± 7		± 9		± 10		mV _{DC}
Input Offset Voltage Drift	$R_S = 0\Omega$	7	15	7	15	7	20	7		7		7		μ V/ $^\circ\text{C}$
Input Offset Current	$I_{IN(+)} - I_{IN(-)}$	± 30		± 30		± 75		± 100		± 150		± 45	± 200	nA _{DC}
Input Offset Current Drift	$R_S = 0\Omega$	10	200	10	200	10	300	10		10		10		pA _{DC} / $^\circ\text{C}$
Input Bias Current	$I_{IN(+)} \text{ or } I_{IN(-)}$	40	100	40	100	40	200	40	300	40	500	40	500	nA _{DC}

Electrical Characteristics (Continued) $V^+ = +5.0 V_{DC}$, Note 4, unless otherwise stated

Parameter	Conditions	LM158A		LM258A		LM358A		LM158/LM258		LM358		LM2904		Units
		Min	Max	Min	Max	Min	Max	Min	Max	Min	Max	Min	Max	
Input Common-Mode Voltage Range	$V^+ = 30 V_{DC}$, (Note 7) (LM2904, $V^+ = 26 V_{DC}$)	0	$V^+ - 2$	0	$V^+ - 2$	0	$V^+ - 2$	0	$V^+ - 2$	0	$V^+ - 2$	0	$V^+ - 2$	V_{DC}
Large Signal Voltage Gain	$V^+ = +15 V_{DC}$ ($V_O = 1 V_{DC}$ to $11 V_{DC}$) $R_L \geq 2 k\Omega$	25	25	15	15	15	15	25	25	15	15	15	15	V/mV
Output Voltage Swing														
V_{OH}	$V^+ = +30 V_{DC}$, $R_L = 2 k\Omega$ $R_L \geq 10 k\Omega$ (LM2904, $V^+ = 26 V_{DC}$) $V^+ = 5 V_{DC}$, $R_L \geq 10 k\Omega$	26	26	26	26	26	26	26	26	26	26	26	26	V_{DC}
V_{OL}	$V^+ = 5 V_{DC}$, $R_L \geq 10 k\Omega$	27	28	27	28	27	28	27	28	27	28	23	24	V_{DC}
Output Current Source	$V_O = 2 V_{DC}$ $V_{IN}^+ = +1 V_{DC}$, $V_{IN}^- = 0 V_{DC}$, $V^+ = 15 V_{DC}$	10	20	10	20	10	20	10	20	10	20	10	20	mA_{DC}
Sink	$V_{IN}^- = +1 V_{DC}$, $V_{IN}^+ = 0 V_{DC}$, $V^+ = 15 V_{DC}$	10	15	5	8	5	8	5	8	5	8	5	8	mA_{DC}

Note 1: For operating at high temperatures, the LM358/LM358A, LM2904 must be derated based on a $+125^\circ C$ maximum junction temperature and a thermal resistance of $120^\circ C/W$ which applies for the device soldered in a printed circuit board, operating in a still air ambient. The LM258/LM258A and LM158/LM158A can be derated based on a $+150^\circ C$ maximum junction temperature. The dissipation is the total of both amplifiers—use external resistors, where possible, to allow the amplifier to saturate or to reduce the power which is dissipated in the integrated circuit.

Note 2: Short circuits from the output to V^+ can cause excessive heating and eventual destruction. When considering short circuits can exceed the power dissipation ratings and cause eventual destruction. Destructive dissipation can result from simultaneous shorts on all amplifiers. V^+ . At values of supply voltage in excess of $+15 V_{DC}$, continuous short-circuits can exceed the power dissipation ratings and cause eventual destruction.

Note 3: This input current will only exist when the voltage at any of the input leads is driven negative. It is due to the collector-base junction of the input PNP transistors becoming forward biased and thereby acting as input diode clamps. In addition to this diode action, there is also lateral NPN parasitic transistor action on the IC chip. This transistor action can cause the output voltages of the op amps to go to the V^+ voltage level (or to ground for a large overdrive) for the time duration that an input is driven negative. This is not destructive and normal output states will re-establish when the input voltage, which was negative, again returns to a value greater than $-0.3 V_{DC}$ (at $25^\circ C$).

Note 4: These specifications are limited to $-55^\circ C \leq T_A \leq +125^\circ C$ for the LM158/LM158A. With the LM258/LM258A, all temperature specifications are limited to $-25^\circ C \leq T_A \leq +85^\circ C$, the LM358/LM358A temperature specifications are limited to $0^\circ C \leq T_A \leq +70^\circ C$, and the LM2904 specifications are limited to $-40^\circ C \leq T_A \leq +85^\circ C$.

Note 5: $V_O \approx 1.4 V_{DC}$, $R_S = 0\Omega$ with V^+ from $5 V_{DC}$ to $30 V_{DC}$; and over the full input common-mode range ($0 V_{DC}$ to $V^+ - 1.5 V_{DC}$) at $25^\circ C$. For LM2904, V^+ from $5 V_{DC}$ to $26 V_{DC}$.

Note 6: The direction of the input current is out of the IC due to the PNP input stage. This current is essentially constant, independent of the state of the output so no loading change exists on the input lines. **Note 7:** The input common-mode voltage of either input signal voltage should not be allowed to go negative by more than $0.3V$ (at $25^\circ C$). The upper end of the common-mode voltage range is $V^+ - 1.5V$ (at $25^\circ C$), but either or both inputs can go to $+32 V_{DC}$ without damage ($+26 V_{DC}$ for LM2904), independent of the magnitude of V^+ .

Note 8: Due to proximity of external components, insure that coupling is not originating via stray capacitance between these external parts. This typically can be detected as this type of capacitance increases at higher frequencies. **Note 9:** Refer to RETS158AX for LM158A military specifications and to RETS158X for LM158 military specifications.

Note 10: Human body model, $1.5 k\Omega$ in series with $100 pF$.

Typical Performance Characteristics

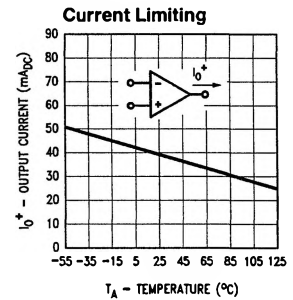
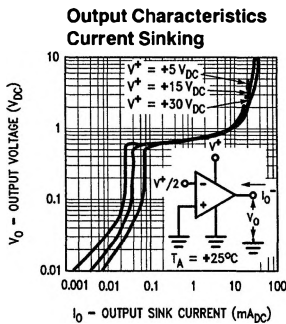
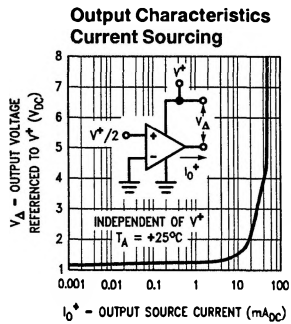
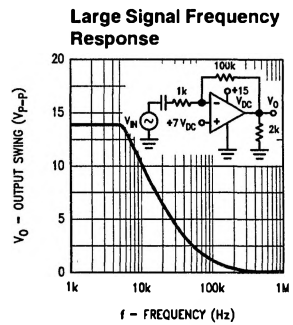
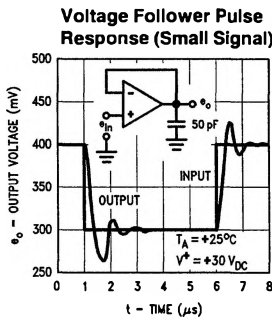
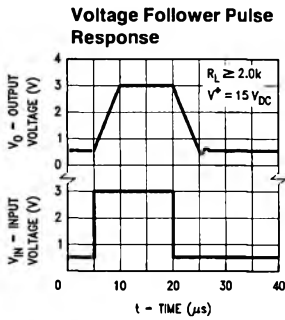
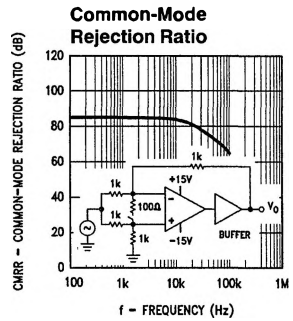
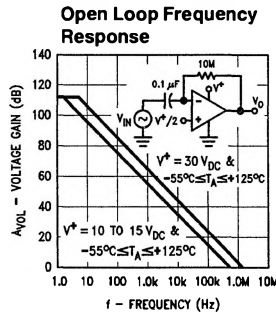
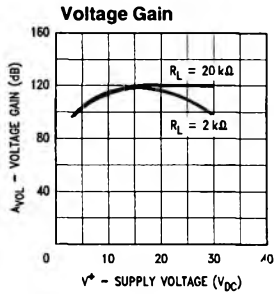
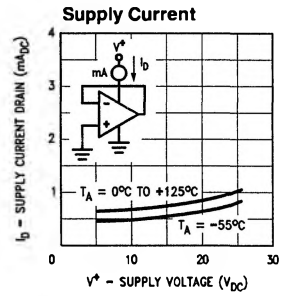
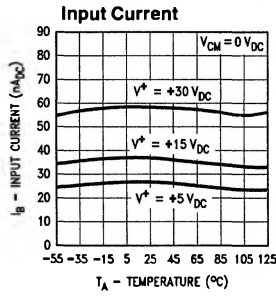
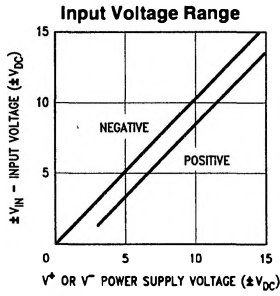

Typical Performance Characteristics (Continued) (LM2902 only)

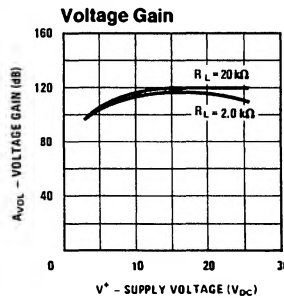
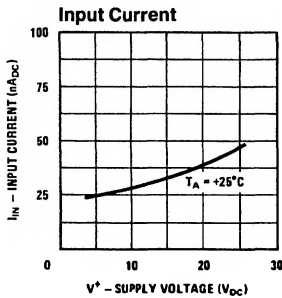

TL/H/7787-5

Application Hints

The LM158 series are op amps which operate with only a single power supply voltage, have true-differential inputs, and remain in the linear mode with an input common-mode voltage of 0 V_{DC} . These amplifiers operate over a wide range of power supply voltage with little change in performance characteristics. At 25°C amplifier operation is possible down to a minimum supply voltage of 2.3 V_{DC} .

Precautions should be taken to insure that the power supply for the integrated circuit never becomes reversed in polarity or that the unit is not inadvertently installed backwards in a test socket as an unlimited current surge through the resulting forward diode within the IC could cause fusing of the internal conductors and result in a destroyed unit.

Large differential input voltages can be easily accommodated and, as input differential voltage protection diodes are not needed, no large input currents result from large differential input voltages. The differential input voltage may be larger than V^+ without damaging the device. Protection should be provided to prevent the input voltages from going negative more than $-0.3 V_{DC}$ (at 25°C). An input clamp diode with a resistor to the IC input terminal can be used.

To reduce the power supply current drain, the amplifiers have a class A output stage for small signal levels which converts to class B in a large signal mode. This allows the amplifiers to both source and sink large output currents. Therefore both NPN and PNP external current boost transistors can be used to extend the power capability of the basic amplifiers. The output voltage needs to raise approximately 1 diode drop above ground to bias the on-chip vertical PNP transistor for output current sinking applications.

For ac applications, where the load is capacitively coupled to the output of the amplifier, a resistor should be used, from the output of the amplifier to ground to increase the class A bias current and prevent crossover distortion. Where the load is directly coupled, as in dc applications, there is no crossover distortion.

Capacitive loads which are applied directly to the output of the amplifier reduce the loop stability margin. Values of 50 pF can be accommodated using the worst-case non-inverting unity gain connection. Large closed loop gains or resistive isolation should be used if larger load capacitance must be driven by the amplifier.

The bias network of the LM158 establishes a drain current which is independent of the magnitude of the power supply voltage over the range of 3 V_{DC} to 30 V_{DC} .

Output short circuits either to ground or to the positive power supply should be of short time duration. Units can be destroyed, not as a result of the short circuit current causing metal fusing, but rather due to the large increase in IC chip dissipation which will cause eventual failure due to excessive function temperatures. Putting direct short-circuits on more than one amplifier at a time will increase the total IC power dissipation to destructive levels, if not properly protected with external dissipation limiting resistors in series with the output leads of the amplifiers. The larger value of output source current which is available at 25°C provides a larger output current capability at elevated temperatures (see typical performance characteristics) than a standard IC op amp.

The circuits presented in the section on typical applications emphasize operation on only a single power supply voltage. If complementary power supplies are available, all of the standard op amp circuits can be used. In general, introducing a pseudo-ground (a bias voltage reference of $V^+ / 2$) will allow operation above and below this value in single power supply systems. Many application circuits are shown which take advantage of the wide input common-mode voltage range which includes ground. In most cases, input biasing is not required and input voltages which range to ground can easily be accommodated.

Typical Single-Supply Applications ($V^+ = 5.0 V_{DC}$)

Non-Inverting DC Gain ($0V \text{ Input} = 0V \text{ Output}$)

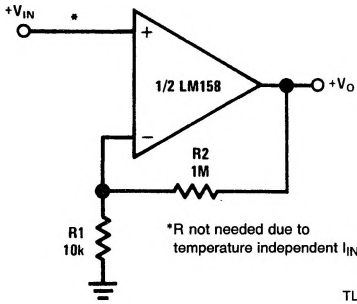

TL/H/7787-6

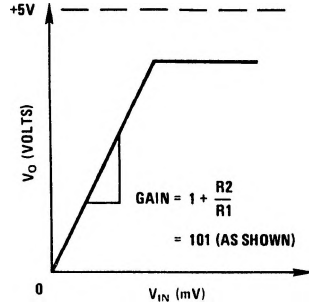

TL/H/7787-7

DC Summing Amplifier ($V_{IN}'S \geq 0 V_{DC}$ and $V_O \geq 0 V_{DC}$)

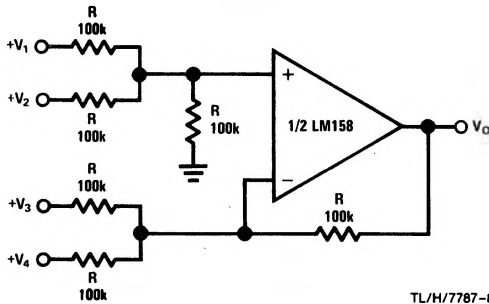

TL/H/7787-8

Where: $V_O = V_1 + V_2 + V_3 + V_4$
 $(V_1 + V_2) \geq (V_3 + V_4)$ to keep $V_O > 0 V_{DC}$

Power Amplifier

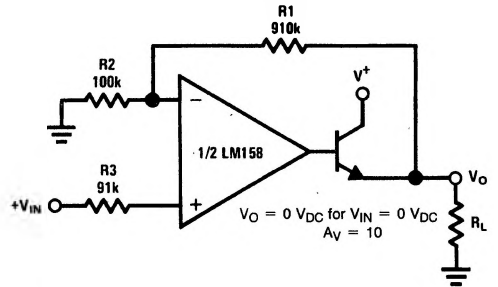

TL/H/7787-9

"BI-QUAD" RC Active Bandpass Filter

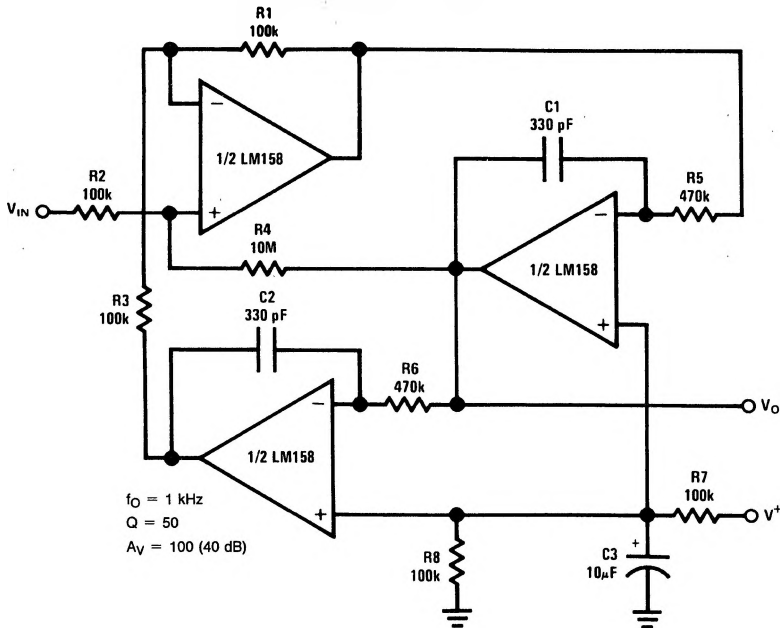

TL/H/7787-10

Typical Single-Supply Applications (V+ = 5.0 V_{DC}) (Continued)

Fixed Current Sources

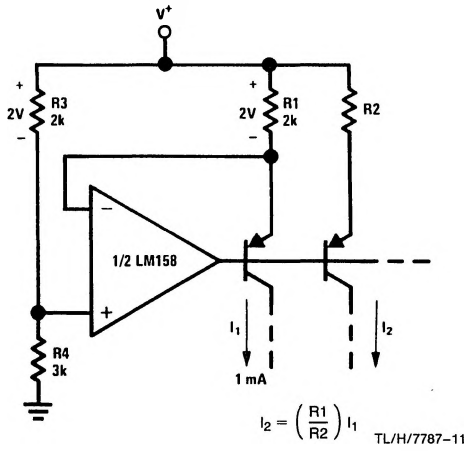

Lamp Driver

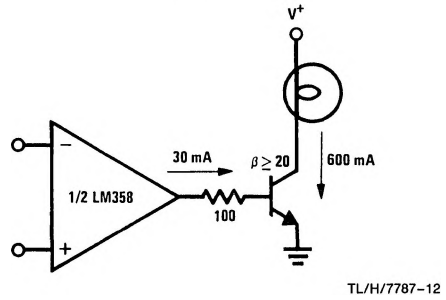

LED Driver

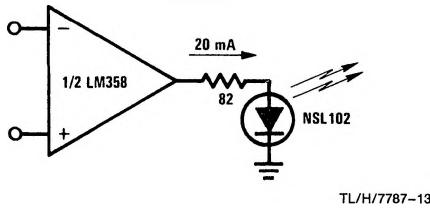

Current Monitor

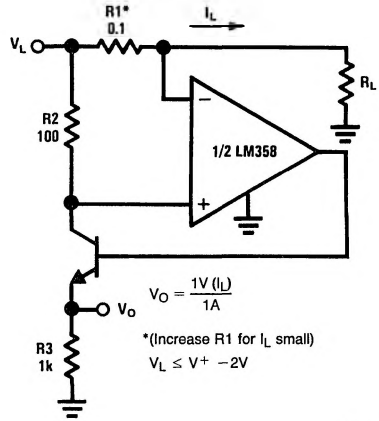

Driving TTL

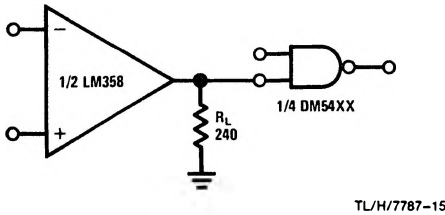

Pulse Generator

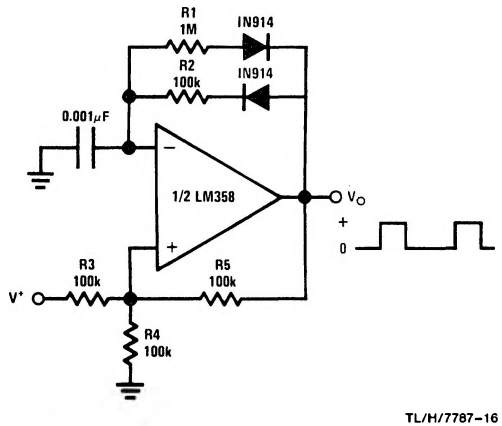

Voltage Follower

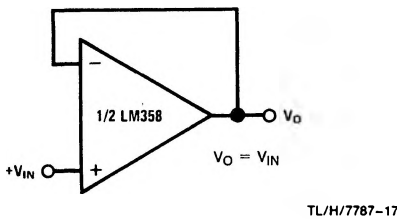

Typical Single-Supply Applications ($V^+ = 5.0 V_{DC}$) (Continued)

Squarewave Oscillator

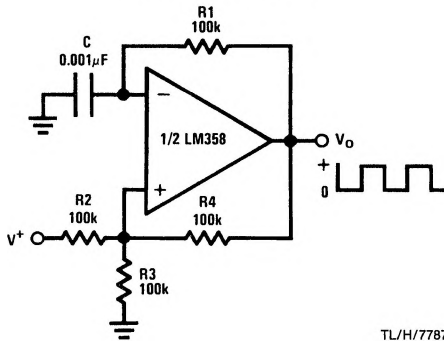

TL/H/7787-18

Pulse Generator

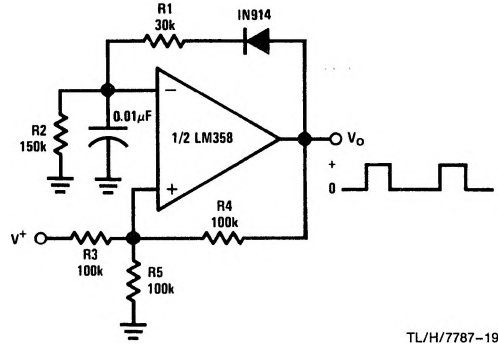

TL/H/7787-19

Low Drift Peak Detector

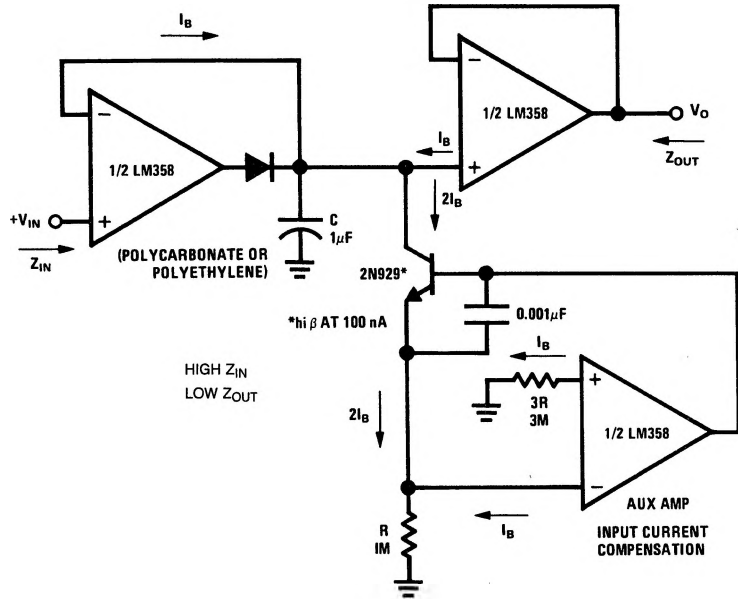

TL/H/7787-20

High Compliance Current Sink

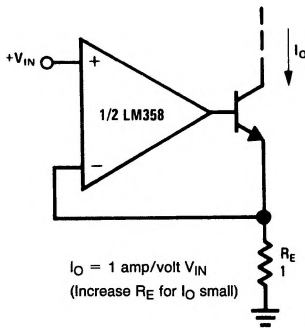

TL/H/7787-21

Comparator with Hysteresis

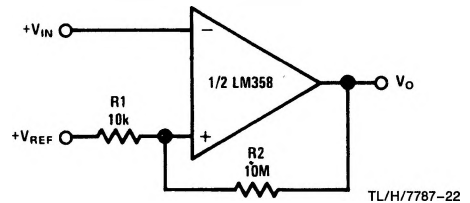

TL/H/7787-22

Typical Single-Supply Applications ($V^+ = 5.0 V_{DC}$) (Continued)

Voltage Controlled Oscillator (VCO)

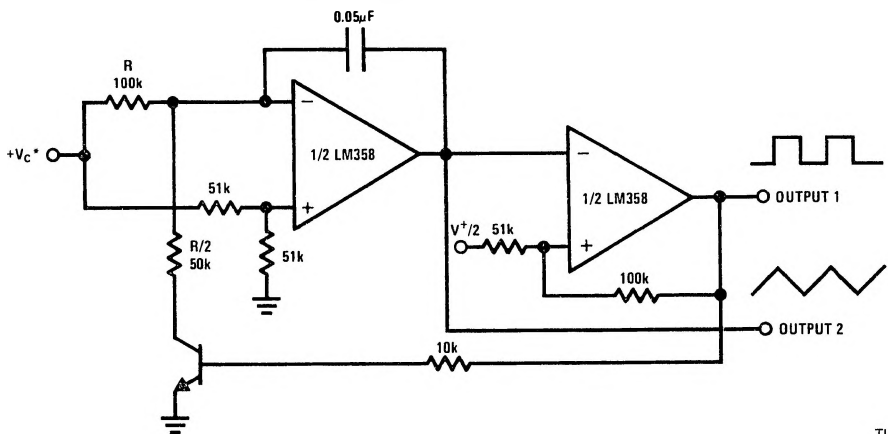

*WIDE CONTROL VOLTAGE RANGE: $0 V_{DC} \leq V_C \leq 2 (V^+ - 1.5V_{DC})$

TL/H/7787-23

AC Coupled Inverting Amplifier

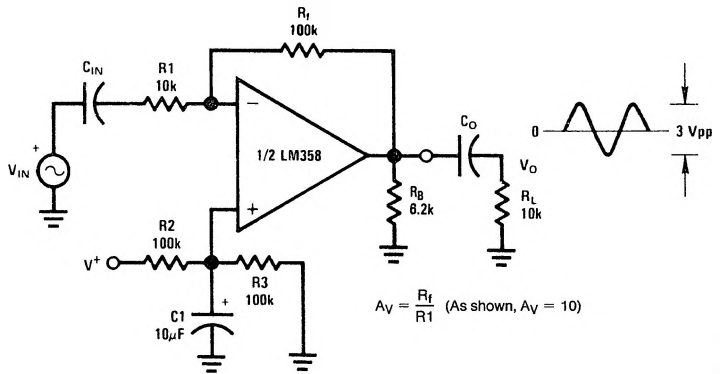

$A_V = \frac{R_f}{R_1}$ (As shown, $A_V = 10$)

TL/H/7787-24

Ground Referencing a Differential Input Signal

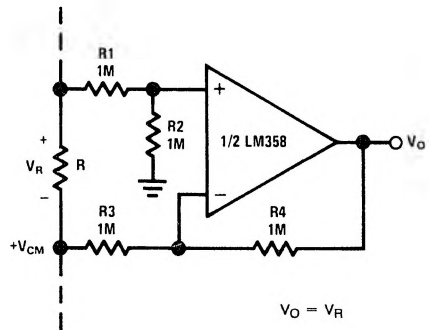

$V_O = V_R$

TL/H/7787-25

Typical Single-Supply Applications ($V^+ = 5.0 V_{DC}$) (Continued)

AC Coupled Non-Inverting Amplifier

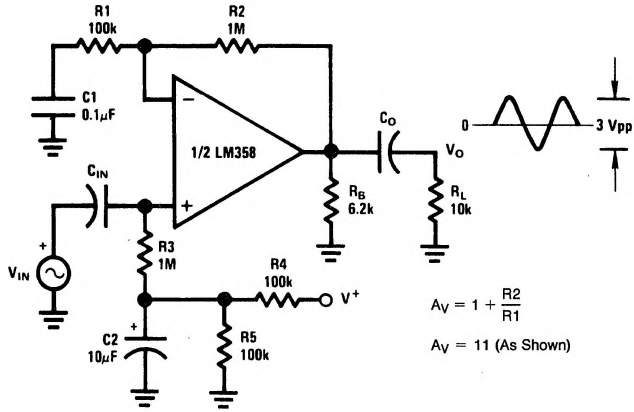

TL/H/7787-26

DC Coupled Low-Pass RC Active Filter

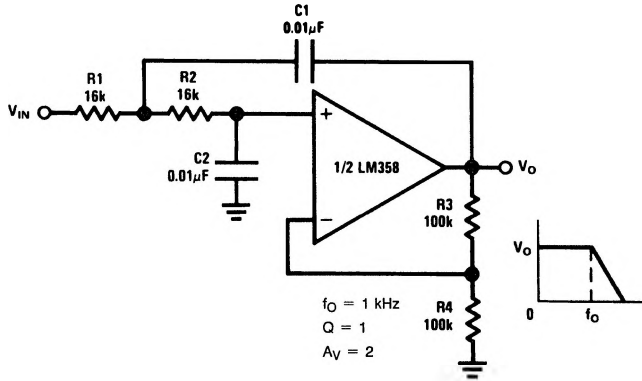

TL/H/7787-27

Bandpass Active Filter

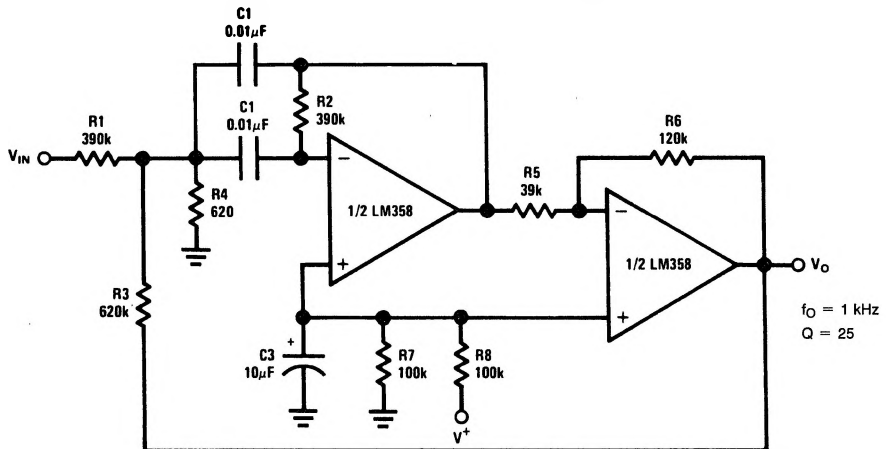

TL/H/7787-28

Typical Single-Supply Applications ($V^+ = 5.0 V_{DC}$) (Continued)

High Input Z, DC Differential Amplifier

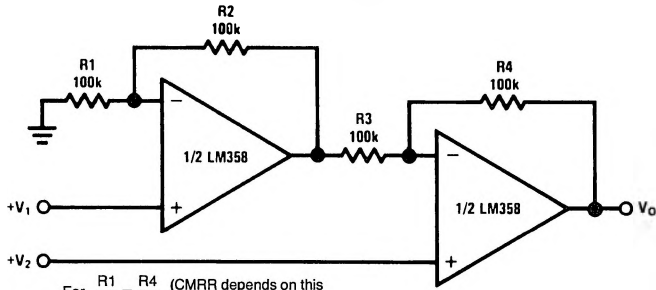

For $\frac{R1}{R2} = \frac{R4}{R3}$ (CMRR depends on this resistor ratio match)

$$V_O = 1 + \frac{R4}{R3} (V_2 - V_1)$$

As Shown: $V_O = 2 (V_2 - V_1)$

TL/H/7787-29

Photo Voltaic-Cell Amplifier

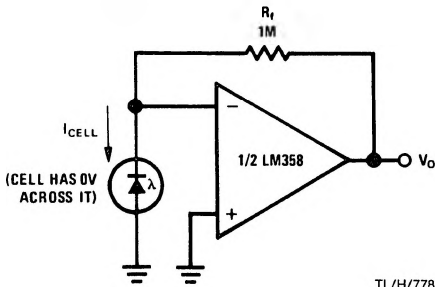

TL/H/7787-30

Bridge Current Amplifier

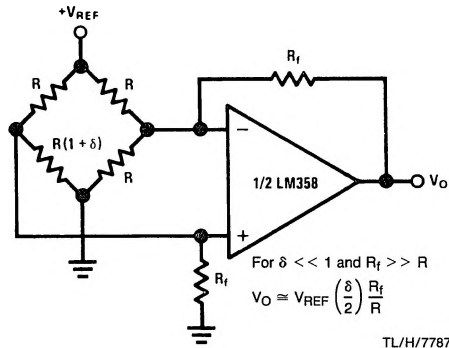

For $\delta \ll 1$ and $R_f \gg R$

$$V_O \approx V_{REF} \left(\frac{\delta}{2} \right) \frac{R_f}{R}$$

TL/H/7787-33

High Input Z Adjustable-Gain DC Instrumentation Amplifier

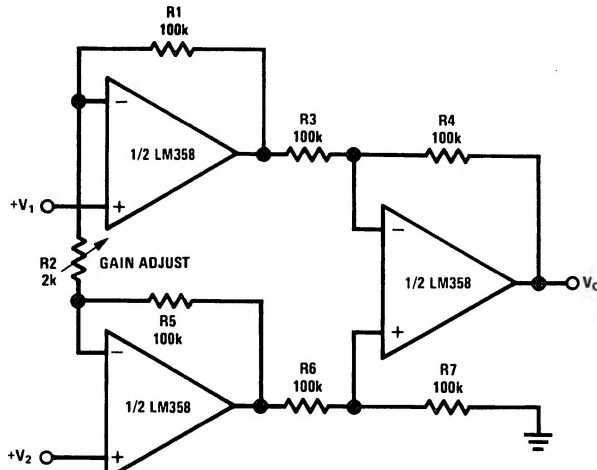

If $R1 = R5$ & $R3 = R4 = R6 = R7$ (CMRR depends on match)

$$V_O = 1 + \frac{2R1}{R2} (V_2 - V_1)$$

As shown $V_O = 101 (V_2 - V_1)$

TL/H/7787-31

Typical Single-Supply Applications ($V^+ = 5.0 \text{ V}_{\text{DC}}$) (Continued)

Using Symmetrical Amplifiers to Reduce Input Current (General Concept)

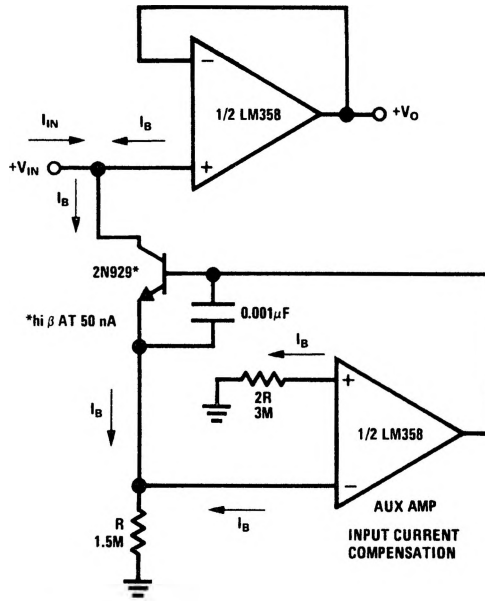

TL/H/7787-32

Schematic Diagram (Each Amplifier)

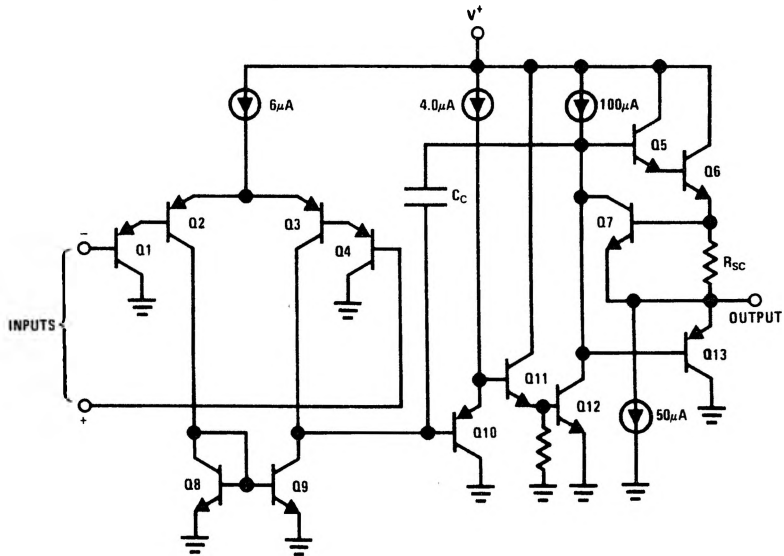

TL/H/7787-3