

LM148/LM149 Series Quad 741 Op Amp

LM148/LM248/LM348 Quad 741 Op Amps

LM149/LM249/LM349 Wide Band Decompensated ($A_V(\text{MIN}) = 5$)

General Description

The LM148 series is a true quad 741. It consists of four independent, high gain, internally compensated, low power operational amplifiers which have been designed to provide functional characteristics identical to those of the familiar 741 operational amplifier. In addition the total supply current for all four amplifiers is comparable to the supply current of a single 741 type op amp. Other features include input offset currents and input bias current which are much less than those of a standard 741. Also, excellent isolation between amplifiers has been achieved by independently biasing each amplifier and using layout techniques which minimize thermal coupling. The LM149 series has the same features as the LM148 plus a gain bandwidth product of 4 MHz at a gain of 5 or greater.

The LM148 can be used anywhere multiple 741 or 1558 type amplifiers are being used and in applications where amplifier matching or high packing density is required.

Features

- 741 op amp operating characteristics
- Low supply current drain 0.6 mA/Amplifier
- Class AB output stage—no crossover distortion
- Pin compatible with the LM124
- Low input offset voltage 1 mV
- Low input offset current 4 nA
- Low input bias current 30 nA
- Gain bandwidth product

LM148 (unity gain)	1.0 MHz
LM149 ($A_V \geq 5$)	4 MHz
- High degree of isolation between amplifiers 120 dB
- Overload protection for inputs and outputs

Schematic Diagram

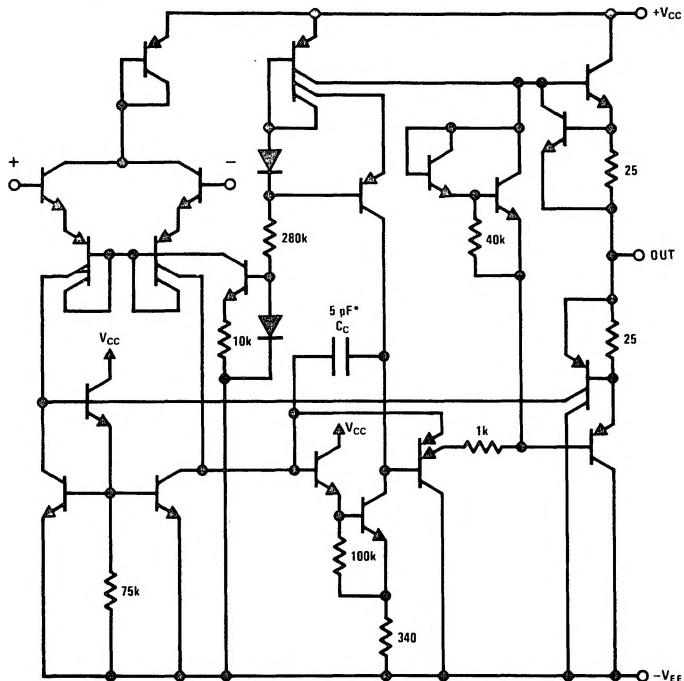

*1 pF in the LM149

Absolute Maximum Ratings

If Military/Aerospace specified devices are required, please contact the National Semiconductor Sales Office/Distributors for availability and specifications.

(Note 4)

	LM148/LM149	LM248/LM249	LM348/LM349
Supply Voltage	±22V	±18V	±18V
Differential Input Voltage	±44V	±36V	±36V
Output Short Circuit Duration (Note 1)	Continuous	Continuous	Continuous
Power Dissipation (P_d at 25°C) and Thermal Resistance (θ_{jA}), (Note 2)			
Molded DIP (N) P_d	—	—	750 mW
θ_{jA}	—	—	100°C/W
Cavity DIP (J) P_d	1100 mW	800 mW	700 mW
θ_{jA}	110°C/W	110°C/W	110°C/W
Maximum Junction Temperature (T_{jMAX})	150°C	110°C	100°C
Operating Temperature Range	-55°C ≤ T_A ≤ +125°C	-25°C ≤ T_A ≤ +85°C	0°C ≤ T_A ≤ +70°C
Storage Temperature Range	-65°C to +150°C	-65°C to +150°C	-65°C to +150°C
Lead Temperature (Soldering, 10 sec.) Ceramic	300°C	300°C	300°C
Lead Temperature (Soldering, 10 sec.) Plastic			260°C
Soldering Information			
Dual-In-Line Package			
Soldering (10 seconds)	260°C	260°C	260°C
Small Outline Package			
Vapor Phase (60 seconds)	215°C	215°C	215°C
Infrared (15 seconds)	220°C	220°C	220°C
See AN-450 "Surface Mounting Methods and Their Effect on Product Reliability" for other methods of soldering surface mount devices.			
ESD tolerance (Note 5)	500V	500V	500V

Electrical Characteristics (Note 3)

Parameter	Conditions	LM148/LM149			LM248/LM249			LM348/LM349			Units
		Min	Typ	Max	Min	Typ	Max	Min	Typ	Max	
Input Offset Voltage	$T_A = 25^\circ\text{C}$, $R_S \leq 10\text{ k}\Omega$		1.0	5.0		1.0	6.0		1.0	6.0	mV
Input Offset Current	$T_A = 25^\circ\text{C}$		4	25		4	50		4	50	nA
Input Bias Current	$T_A = 25^\circ\text{C}$		30	100		30	200		30	200	nA
Input Resistance	$T_A = 25^\circ\text{C}$	0.8	2.5		0.8	2.5		0.8	2.5		MΩ
Supply Current All Amplifiers	$T_A = 25^\circ\text{C}$, $V_S = \pm 15\text{V}$		2.4	3.6		2.4	4.5		2.4	4.5	mA
Large Signal Voltage Gain	$T_A = 25^\circ\text{C}$, $V_S = \pm 15\text{V}$ $V_{OUT} = \pm 10\text{V}$, $R_L \geq 2\text{ k}\Omega$	50	160		25	160		25	160		V/mV
Amplifier to Amplifier Coupling	$T_A = 25^\circ\text{C}$, $f = 1\text{ Hz to } 20\text{ kHz}$ (Input Referred) See Crosstalk Test Circuit		-120			-120			-120		dB
Small Signal Bandwidth	LM148 Series		1.0			1.0			1.0		MHz
	LM149 Series		4.0			4.0			4.0		MHz
Phase Margin	LM148 Series ($A_V = 1$)		60			60			60		degrees
	LM149 Series ($A_V = 5$)		60			60			60		degrees
Slew Rate	LM148 Series ($A_V = 1$)		0.5			0.5			0.5		V/μs
	LM149 Series ($A_V = 5$)		2.0			2.0			2.0		V/μs
Output Short Circuit Current	$T_A = 25^\circ\text{C}$		25			25			25		mA
Input Offset Voltage	$R_S \leq 10\text{ k}\Omega$			6.0			7.5			7.5	mV
Input Offset Current				75			125			100	nA
Input Bias Current				325			500			400	nA

Electrical Characteristics (Note 3) (Continued)

Parameter	Conditions	LM148/LM149			LM248/LM249			LM348/LM349			Units
		Min	Typ	Max	Min	Typ	Max	Min	Typ	Max	
Large Signal Voltage Gain	$V_S = \pm 15V, V_{OUT} = \pm 10V,$ $R_L > 2 k\Omega$	25			15			15			V/mV
Output Voltage Swing	$V_S = \pm 15V, R_L = 10 k\Omega$ $R_L = 2 k\Omega$	± 12 ± 10	± 13 ± 12		± 12 ± 10	± 13 ± 12		± 12 ± 10	± 13 ± 12		V V
Input Voltage Range	$V_S = \pm 15V$	± 12			± 12			± 12			V
Common-Mode Rejection Ratio	$R_S \leq 10 k\Omega$	70	90		70	90		70	90		dB
Supply Voltage Rejection	$R_S \leq 10 k\Omega, \pm 5V \leq V_S \leq \pm 15V$	77	96		77	96		77	96		dB

Note 1: Any of the amplifier outputs can be shorted to ground indefinitely; however, more than one should not be simultaneously shorted as the maximum junction temperature will be exceeded.

Note 2: The maximum power dissipation for these devices must be derated at elevated temperatures and is dictated by T_{jMAX}, θ_{jA} , and the ambient temperature, T_A . The maximum available power dissipation at any temperature is $P_d = (T_{jMAX} - T_A)/\theta_{jA}$ or the $25^\circ C P_{dMAX}$, whichever is less.

Note 3: These specifications apply for $V_S = \pm 15V$ and over the absolute maximum operating temperature range ($T_L \leq T_A \leq T_H$) unless otherwise noted.

Note 4: Refer to RETS 148X for LM148 military specifications.

Note 5: Human body model, 1.5 k Ω in series with 100 pF.

Cross Talk Test Circuit

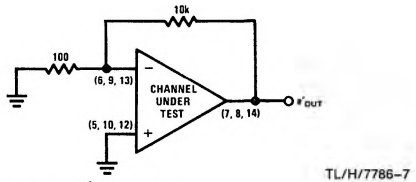
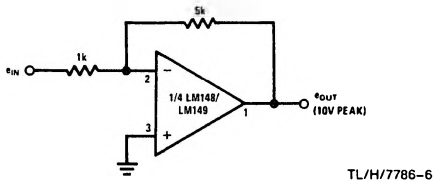

$$\text{Crosstalk} = -20 \log \frac{e'_{OUT}}{101 \times e_{OUT}} \text{ (dB)}$$

$V_S = \pm 15V$

Application Hints

The LM148 series are quad low power 741 op amps. In the proliferation of quad op amps, these are the first to offer the convenience of familiar, easy to use operating characteristics of the 741 op amp. In those applications where 741 op amps have been employed, the LM148 series op amps can be employed directly with no change in circuit performance.

The LM149 series has the same characteristics as the LM148 except it has been decompensated to provide a wider bandwidth. As a result the part requires a minimum gain of 5.

The package pin-outs are such that the inverting input of each amplifier is adjacent to its output. In addition, the amplifier outputs are located in the corners of the package which simplifies PC board layout and minimizes package related capacitive coupling between amplifiers.

The input characteristics of these amplifiers allow differential input voltages which can exceed the supply voltages. In addition, if either of the input voltages is within the operating common-mode range, the phase of the output remains correct. If the negative limit of the operating common-mode range is exceeded at both inputs, the output voltage will be positive. For input voltages which greatly exceed the maximum supply voltages, either differentially or common-mode, resistors should be placed in series with the inputs to limit the current.

Like the LM741, these amplifiers can easily drive a 100 pF capacitive load throughout the entire dynamic output voltage and current range. However, if very large capacitive loads must be driven by a non-inverting unity gain amplifier, a resistor should be placed between the output (and feed-

back connection) and the capacitance to reduce the phase shift resulting from the capacitive loading.

The output current of each amplifier in the package is limited. Short circuits from an output to either ground or the power supplies will not destroy the unit. However, if multiple output shorts occur simultaneously, the time duration should be short to prevent the unit from being destroyed as a result of excessive power dissipation in the IC chip.

As with most amplifiers, care should be taken lead dress, component placement and supply decoupling in order to ensure stability. For example, resistors from the output to an input should be placed with the body close to the input to minimize "pickup" and maximize the frequency of the feedback pole which capacitance from the input to ground creates.

A feedback pole is created when the feedback around any amplifier is resistive. The parallel resistance and capacitance from the input of the device (usually the inverting input) to AC ground set the frequency of the pole. In many instances the frequency of this pole is much greater than the expected 3 dB frequency of the closed loop gain and consequently there is negligible effect on stability margin. However, if the feedback pole is less than approximately six times the expected 3 dB frequency a lead capacitor should be placed from the output to the input of the op amp. The value of the added capacitor should be such that the RC time constant of this capacitor and the resistance it parallels is greater than or equal to the original feedback pole time constant.

Typical Performance Characteristics

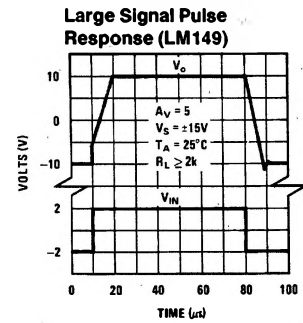
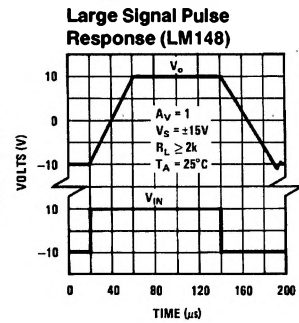
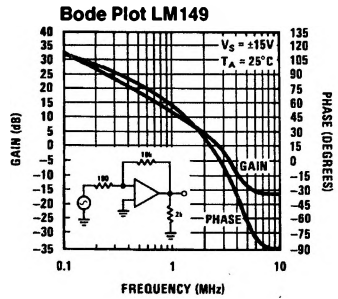
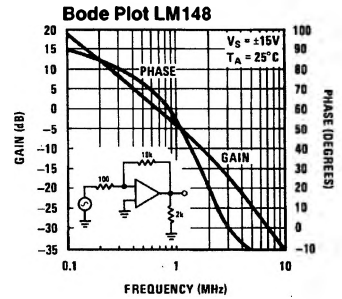
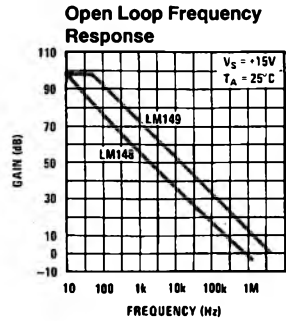
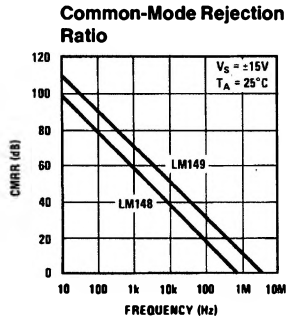
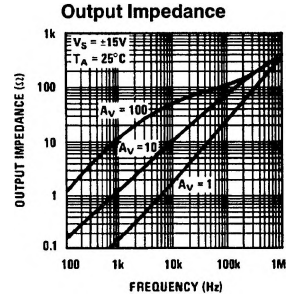
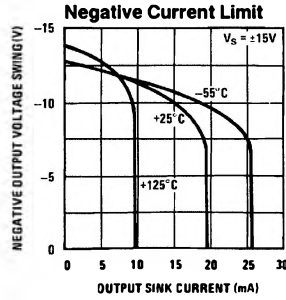
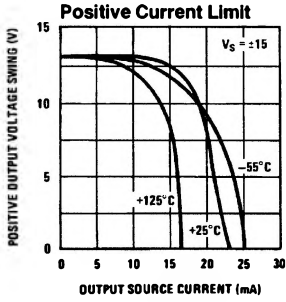
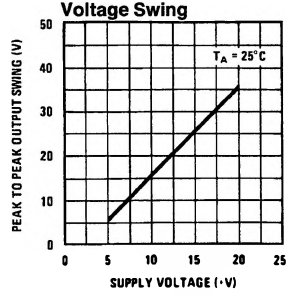
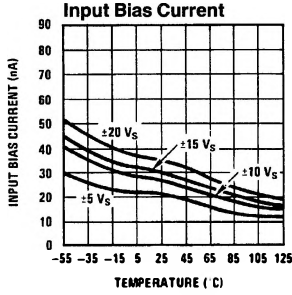
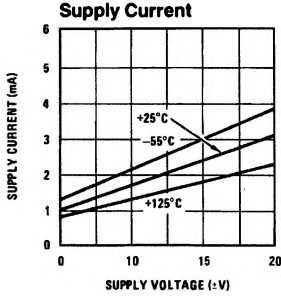

Typical Performance Characteristics (Continued)

Small Signal Pulse Response (LM148)

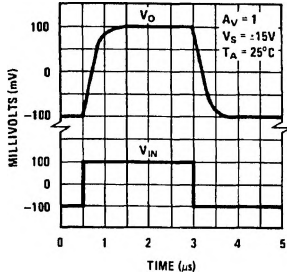

Small Signal Pulse Response (LM149)

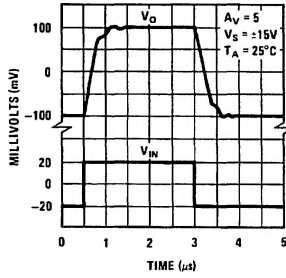

Undistorted Output Voltage Swing

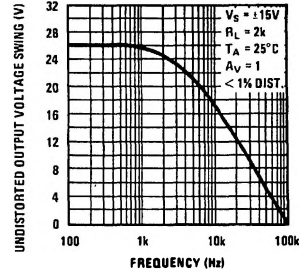

Gain Bandwidth

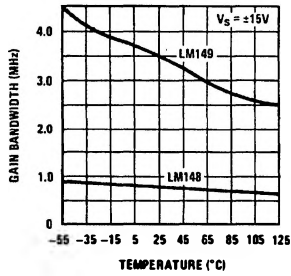

Slew Rate

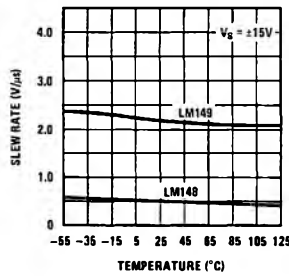

Inverting Large Signal Pulse Response (LM149)

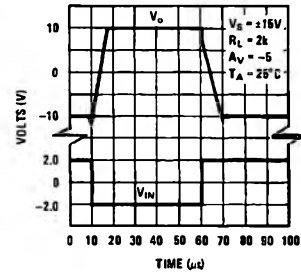

Inverting Large Signal Pulse Response (LM148)

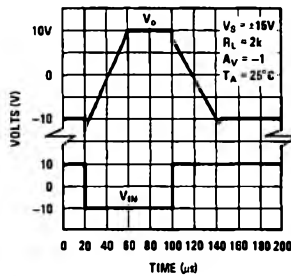

Input Noise Voltage and Noise Current

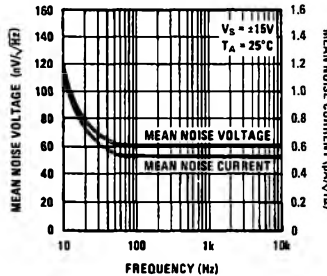

Positive Common-Mode Input Voltage Limit

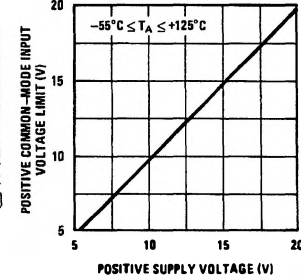

TL/H/7786-4

Negative Common-Mode Input Voltage Limit

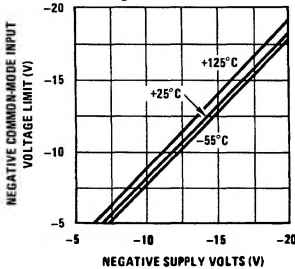

TL/H/7786-5

Typical Applications—LM148

One Decade Low Distortion Sinewave Generator

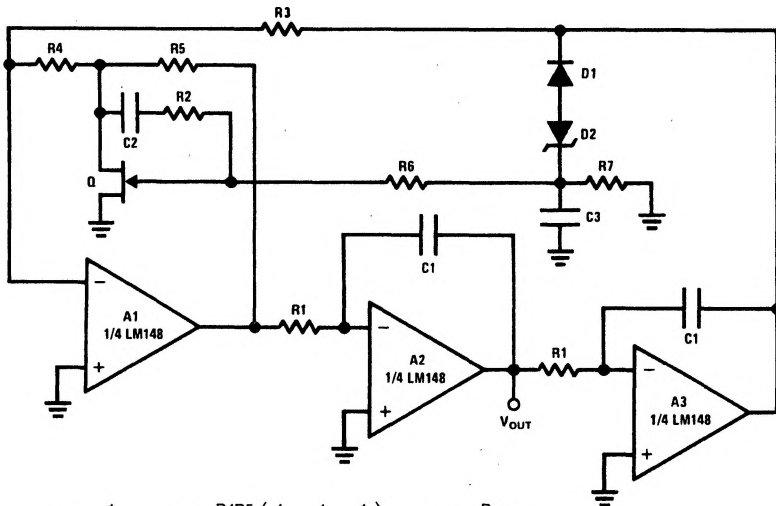

$$f = \frac{1}{2\pi R1C1} \times \sqrt{K}, K = \frac{R4R5}{R3} \left(\frac{1}{r_{DS}} + \frac{1}{R4} + \frac{1}{R5} \right), r_{DS} \approx \frac{R_{ON}}{\left(1 - \frac{V_{GS}}{V_P}\right)^{1/2}}$$

TL/H/7786-8

f_{MAX} = 5 KHz, THD ≤ 0.03%

R1 = 100k pot. C1 = 0.0047 μF, C2 = 0.01 μF, C3 = 0.1 μF, R2 = R6 = R7 = 1M,
 R3 = 5.1k, R4 = 12Ω, R5 = 240Ω, Q = NS5102, D1 = 1N914, D2 = 3.6V avalanche diode (ex. LM103), V_S = ±15V

A simpler version with some distortion degradation at high frequencies can be made by using A1 as a simple inverting amplifier, and by putting back to back zeners in the feedback loop of A3.

Low Cost Instrumentation Amplifier

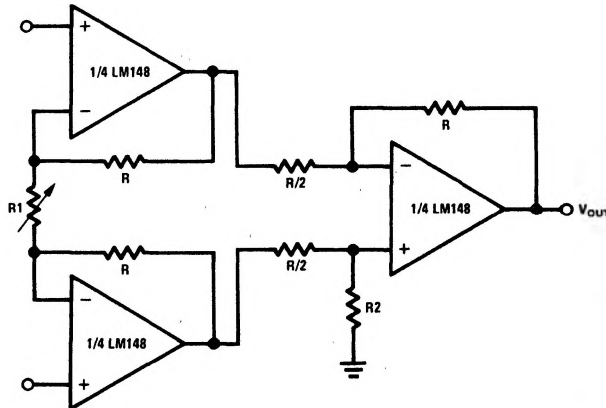

TL/H/7786-9

$$V_{OUT} = 2 \left(\frac{2R}{R1} + 1 \right), V_S - 3V \leq V_{INCM} \leq V_S^+ - 3V,$$

V_S = ±15V

R = R2, trim R2 to boost CMRR

Typical Applications—LM148 (Continued)

Low Drift Peak Detector with Bias Current Compensation

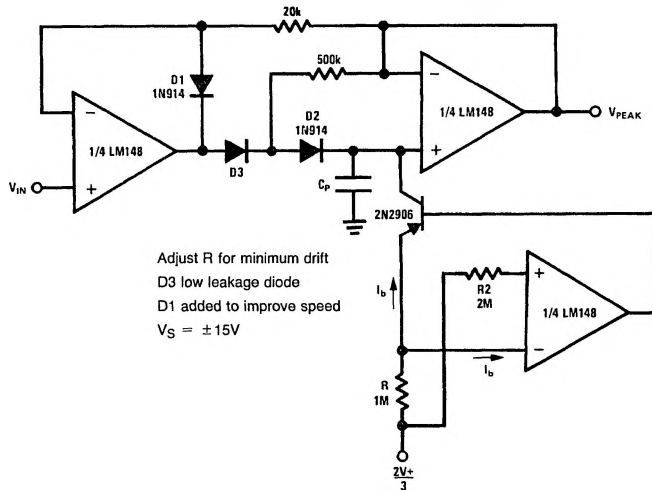

TL/H/7786-10

Universal State-Variable Filter

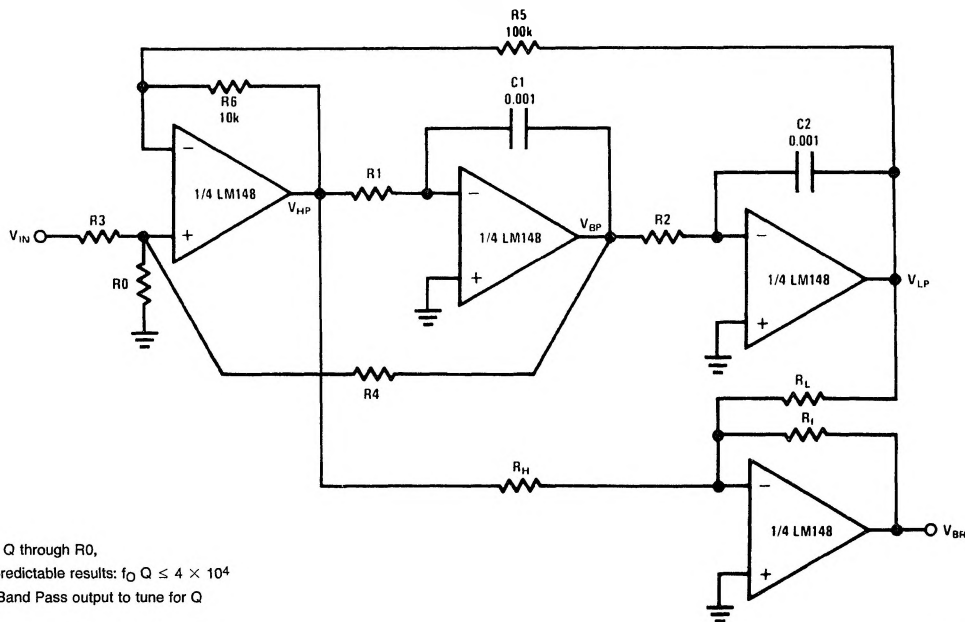

Tune Q through R0,

For predictable results: $f_0 Q \leq 4 \times 10^4$

Use Band Pass output to tune for Q

$$\frac{V(s)}{V_{IN}(s)} = \frac{N(s)}{D(s)}, \quad D(s) = S^2 + \frac{S\omega_0}{Q} + \omega_0^2$$

$$N_{HP}(s) = S^2 H_{OHP}, \quad N_{BP}(s) = \frac{-s\omega_0 H_{OHP}}{Q}, \quad N_{LP} = \omega_0^2 H_{OHP}$$

$$f_0 = \frac{1}{2\pi} \sqrt{\frac{R_6}{R_5} \frac{1}{1112}}, \quad t_1 = R_1 C_1, \quad Q = \left(\frac{1 + R_4/R_3 + R_4/R_0}{1 + R_6/R_5} \right) \left(\frac{R_6 t_1}{R_5 t_2} \right)^{1/2}$$

$$f_{NOTCH} = \frac{1}{2\pi} \left(\frac{R_H}{R_L t_1 t_2} \right)^{1/2}, \quad H_{OHP} = \frac{1 + R_6/R_5}{1 + R_3/R_0 + R_3/R_4}, \quad H_{OHP} = \frac{1 + R_4/R_3 + R_4/R_0}{1 + R_3/R_0 + R_3/R_4}$$

$$H_{OLP} = \frac{1 + R_5/R_6}{1 + R_3/R_0 + R_3/R_4}$$

TL/H/7786-11

Typical Applications—LM148 (Continued)

A 1 kHz 4 Pole Butterworth

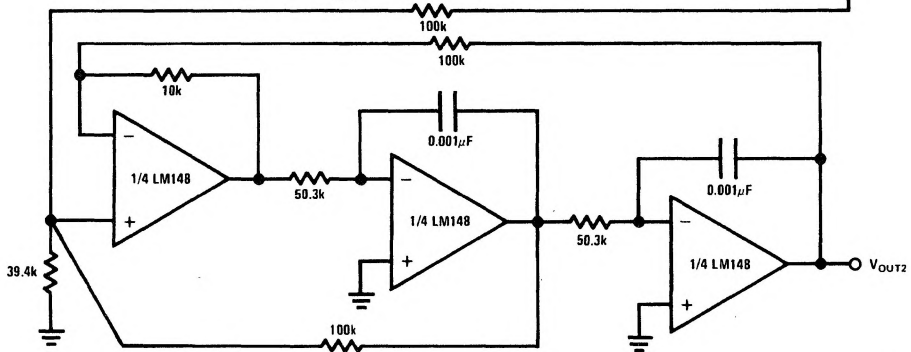
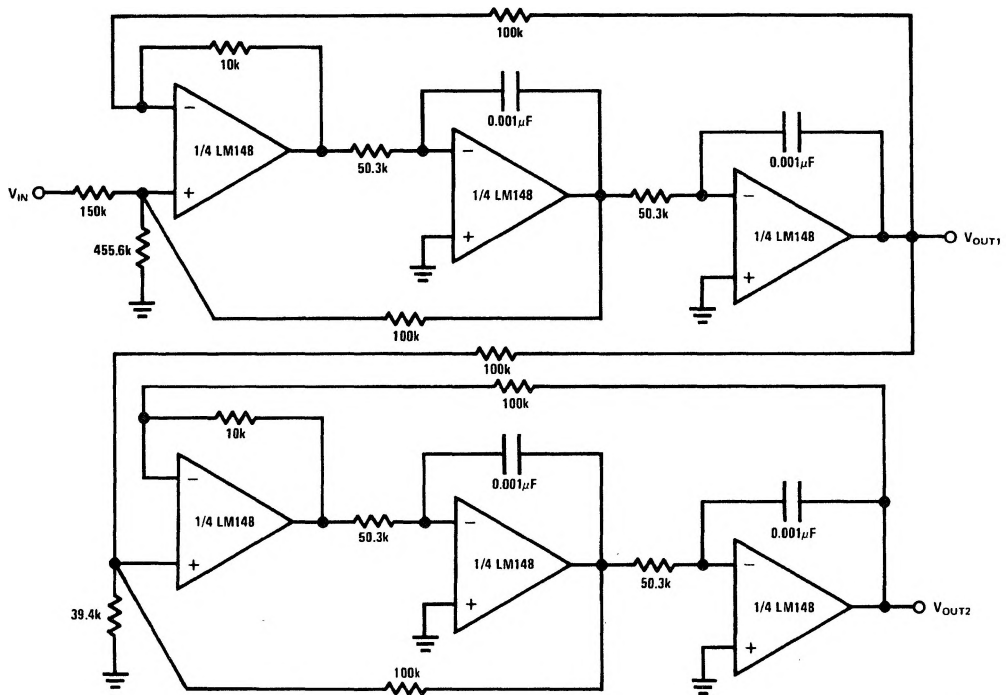

Use general equations, and tune each section separately

$$Q_{1stSECTION} = 0.541, Q_{2ndSECTION} = 1.306$$

The response should have 0 dB peaking

TL/H/7786-12

A 3 Amplifier Bi-Quad Notch Filter

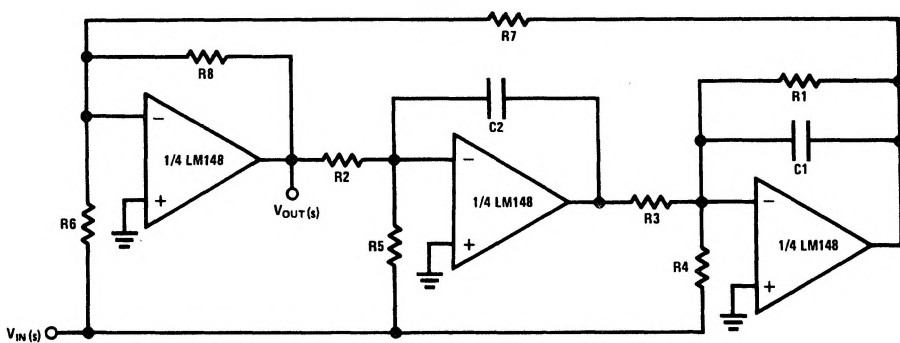

$$Q = \sqrt{\frac{R8}{R7}} \times \frac{R1C1}{\sqrt{R3C2R2C1}}, f_o = \frac{1}{2\pi} \sqrt{\frac{R8}{R7}} \times \frac{1}{\sqrt{R2R3C1C2}}, f_{NOTCH} = \frac{1}{2\pi} \sqrt{\frac{R6}{R3R5R7C1C2}}$$

$$\text{Necessary condition for notch: } \frac{1}{R6} = \frac{R1}{R4R7}$$

Ex: $f_{NOTCH} = 3 \text{ kHz}, Q = 5, R1 = 270k, R2 = R3 = 20k, R4 = 27k, R5 = 20k, R6 = R8 = 10k, R7 = 100k, C1 = C2 = 0.001 \mu\text{F}$

Better noise performance than the state-space approach.

TL/H/7786-13

Typical Applications—LM148 (Continued)

A 4th Order 1 kHz Elliptic Filter (4 Poles, 4 Zeros)

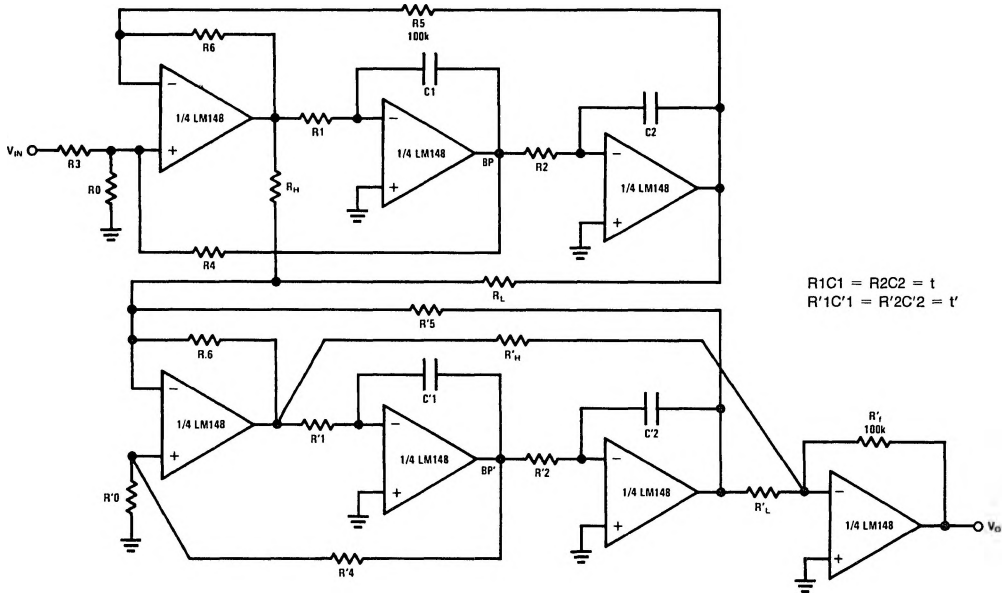

$$R_1 C_1 = R_2 C_2 = t$$

$$R'_1 C'_1 = R'_2 C'_2 = t'$$

TL/H/7786-14

$f_C = 1 \text{ kHz}$, $f_S = 2 \text{ kHz}$, $f_p = 0.543$, $f_z = 2.14$, $Q = 0.841$, $f'_p = 0.987$, $f'_z = 4.92$, $Q' = 4.403$, normalized to ripple BW

$$f_p = \frac{1}{2\pi} \sqrt{\frac{R_6}{R_5}} \times \frac{1}{t}, \quad f_z = \frac{1}{2\pi} \sqrt{\frac{R_H}{R_L}} \times \frac{1}{t'}, \quad Q = \left(\frac{1 + R_4/R_3 + R_4/R_0}{1 + R_6/R_5} \right) \times \sqrt{\frac{R_6}{R_5}}, \quad Q' = \sqrt{\frac{R'_6}{R'_5}} \frac{1 + R'_4/R'_0}{1 + R'_6/R'_5 + R'_6/R'_P}$$

$$R_P = \frac{R_H R_L}{R_H + R_L}$$

Use the BP outputs to tune Q , Q' , tune the 2 sections separately

$R_1 = R_2 = 92.6\text{k}$, $R_3 = R_4 = R_5 = 100\text{k}$, $R_6 = 10\text{k}$, $R_0 = 107.8\text{k}$, $R_L = 100\text{k}$, $R_H = 155.1\text{k}$,

$R'_1 = R'_2 = 50.9\text{k}$, $R'_4 = R'_5 = 100\text{k}$, $R'_6 = 10\text{k}$, $R'_0 = 5.78\text{k}$, $R'_L = 100\text{k}$, $R'_H = 248.12\text{k}$, $R'_f = 100\text{k}$. All capacitors are $0.001 \mu\text{F}$.

Lowpass Response

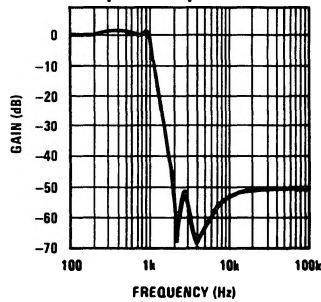

TL/H/7786-15

Typical Applications—LM149

Minimum Gain to Insure LM149 Stability

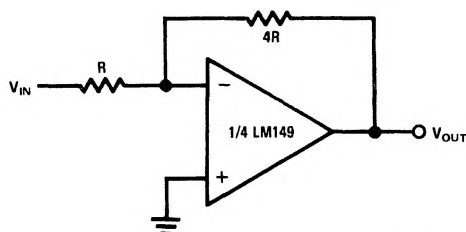

TL/H/7786-16

$$ACL(s) = \frac{V_{OUT}}{V_{IN}} = \frac{-4}{\left(1 + \frac{5}{AOL(s)}\right)} \approx -4$$

$$V_O \Big|_{V_{IN} = 0} \approx \pm 5 V_{OS}$$

Power BW = 40 kHz

Small Signal BW = G BW/5

The LM149 as a Unity Gain Inverter

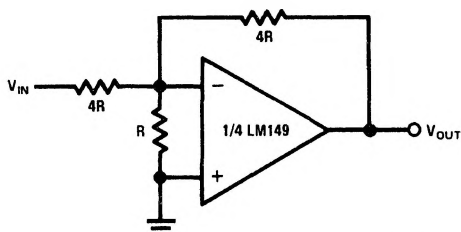

TL/H/7786-17

$$ACL(s) = \frac{V_{OUT}}{V_{IN}} = \left(\frac{-1}{1 + \frac{6}{AOL(s)}\right) \approx -1$$

$$V_O \Big|_{V_{IN} = 0} \approx \pm 5 V_{OS}$$

Small Signal BW = G BW/5

Non-inverting-Integrator Bandpass Filter

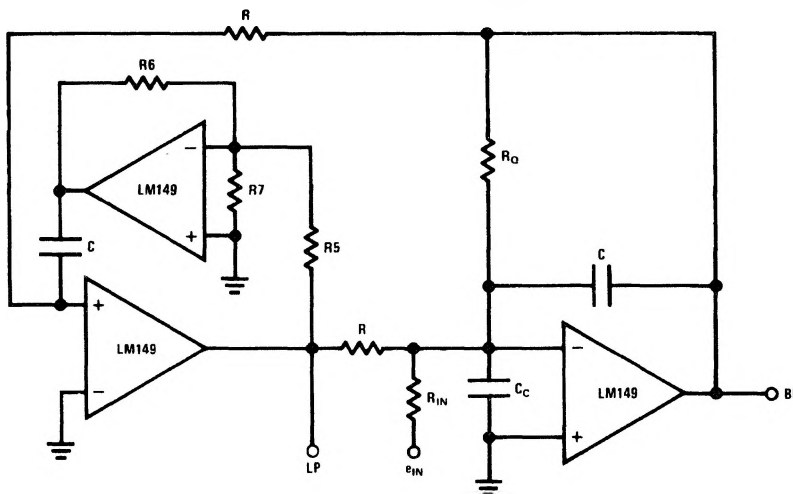

TL/H/7786-18

For stability purposes: $R7 = R6/4$, $10R6 = R5$, $C_C = 10C$

$$f_O = \frac{1}{2\pi} \sqrt{\frac{R5}{R6}} \times \frac{1}{RC}, \quad Q = \frac{R_O}{R} \sqrt{\frac{R5}{R6}}, \quad H_{O_{BP}} = \frac{R_O}{R_{IN}}$$

$f_{O(MAX)}, Q_{MAX} = 20 \text{ kHz}, 10$

Better Q sensitivity with respect to open loop gain variations than the state variable filter.

R7, C_C added for compensation

Typical Applications—LM149 (Continued)

Active Tone Control with Full Output Swing (No Slew Limiting at 20 kHz)

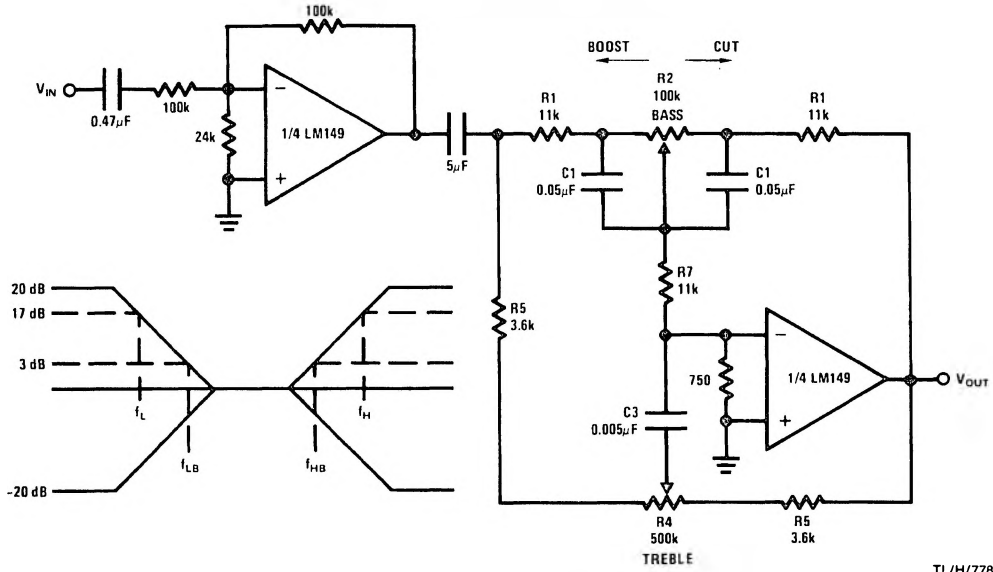

TL/H/7786-19

$V_S = \pm 15V$, $V_{OUT(MAX)} = 9.1 V_{RMS}$,
 $f_{MAX} = 20 \text{ kHz}$, THD $\leq 1\%$
 Duplicate the above circuit for stereo

$$f_L = \frac{1}{2\pi R2C1}, f_{LB} = \frac{1}{2\pi R1C1}$$

$$f_H = \frac{1}{2\pi R5C3}, f_{HB} = \frac{1}{2\pi (R1 + 2R7) C3}$$

Max Bass Gain $\approx (R1 + R2)/R1$
 Max Treble Gain $\approx (R1 + 2R7)/R5$
 as shown: $f_L \approx 32 \text{ Hz}$, $f_{LB} \approx 320 \text{ Hz}$
 $f_H \approx 11 \text{ kHz}$, $f_{HB} \approx 1.1 \text{ Hz}$

Triangular Squarewave Generator

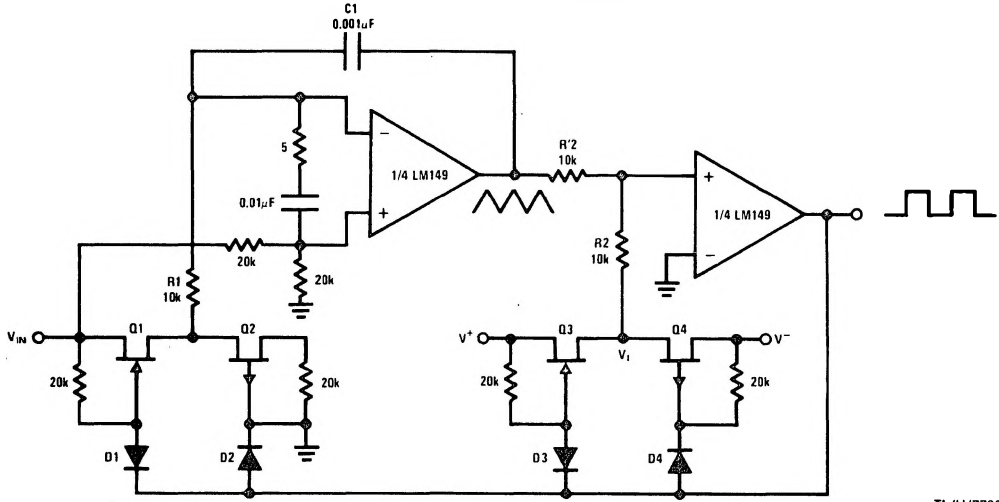

TL/H/7786-20

$$f = \frac{K \times V_{IN}}{8V^+ C1R1}, K = R2/R'2, \frac{2V_1}{K} \leq 25V, V^+ = V^-, V_S = \pm 15V$$

Use LM125 for $\pm 15V$ supply
 The circuit can be used as a low frequency V/F for process control.
 Q1, Q3: KE4393, Q2, Q4: P1087E, D1-D4 = 1N914

Typical Simulation

LM148, LM149, LM741 Macromodel for Computer Simulation

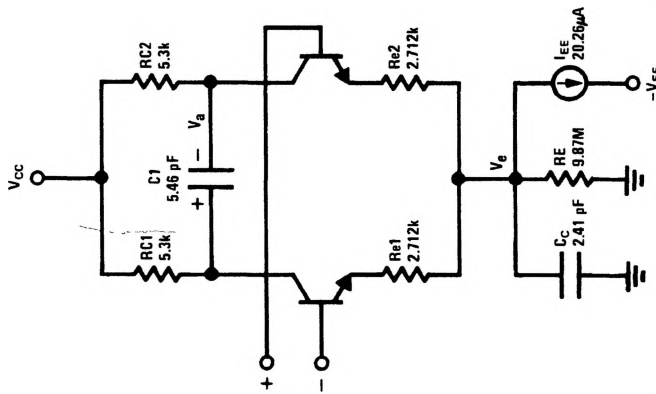

TL/H/7786-21

$\beta_{01} = 112$ $I_S = 8 \times 10^{-16}$

$\beta_{02} = 144$ *C2 = 6 pF for LM149

For more details, see IEEE Journal of Solid-State Circuits, Vol. SC-9, No. 6, December 1974

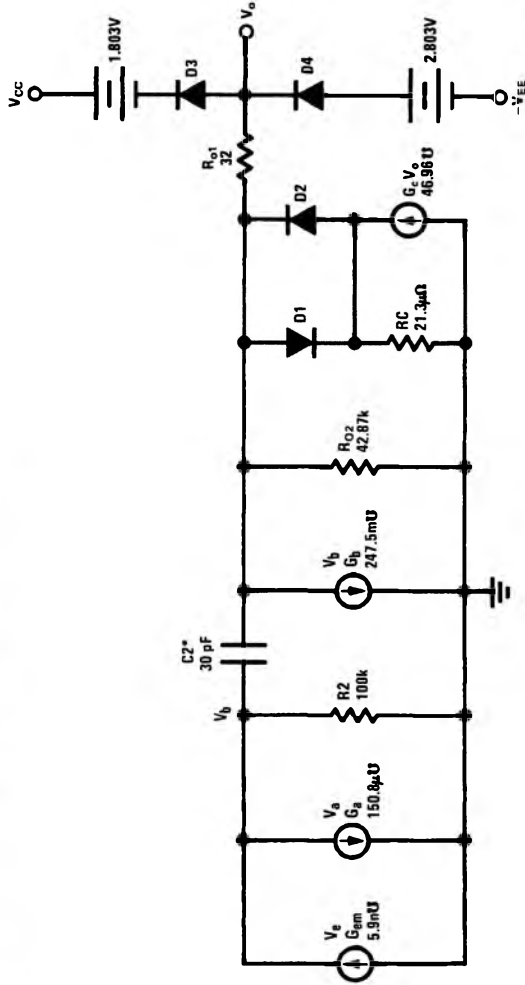

TL/H/7786-22

Connection Diagram

Dual-In-Line Package

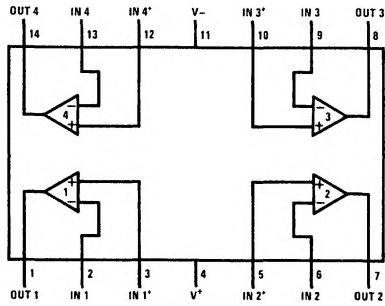

TL/H/7786-2

Top View

Order Number LM148J, LM248J, LM348J, LM149J, LM249J, LM349J, LM348M, LM348N or LM349N
See NS Package Number J14A, M14A or N14A

LM148/LM149/LM248/LM249/LM348/LM349