

LM143/LM343 High Voltage Operational Amplifier

General Description

The LM143 is a general purpose high voltage operational amplifier featuring operation to $\pm 40V$, complete input over-voltage protection up to $\pm 40V$ and input currents comparable to those of other super- β op amps. Increased slew rate, together with higher common-mode and supply rejection, insure improved performance at high supply voltages. Operating characteristics, in particular supply current, slew rate and gain, are virtually independent of supply voltage and temperature. Furthermore, gain is unaffected by output loading at high supply voltages due to thermal symmetry on the die. The LM143 is pin compatible with general purpose op amps and has offset null capability.

Application areas include those of general purpose op amps, but can be extended to higher voltages and higher output power when externally boosted. For example, when used in audio power applications, the LM143 provides a power bandwidth that covers the entire audio spectrum. In addition, the LM143 can be reliably operated in environments with large overvoltage spikes on the power supplies, where other internally-compensated op amps would suffer catastrophic failure.

The LM343 is similar to the LM143 for applications in less severe supply voltage and temperature environments.

Features

- Wide supply voltage range $\pm 4.0V$ to $\pm 40V$
- Large output voltage swing $\pm 37V$
- Wide input common-mode range $\pm 38V$
- Input overvoltage protection Full $\pm 40V$
- Supply current is virtually independent of supply voltage and temperature

Unique Characteristics

- Low input bias current 8.0 nA
- Low input offset current 1.0 nA
- High slew rate—essentially independent of temperature and supply voltage $2.5V/\mu s$
- High voltage gain—virtually independent of resistive loading, temperature, and supply voltage 100k min
- Internally compensated for unity gain
- Output short circuit protection
- Pin compatible with general purpose op amps

Connection Diagram

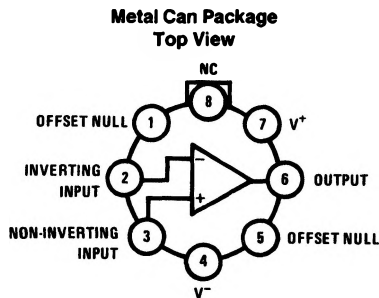

Order Number LM143H, LM143H/883* or LM343H
See NS Package Number H08C

*Available per SMD # 7800303

Absolute Maximum Ratings (Note 1)

If Military/Aerospace specified devices are required, please contact the National Semiconductor Sales Office/Distributors for availability and specifications.

(Note 4)

	LM143	LM343
Supply Voltage	±40V	±34V
Power Dissipation (Note 1)	680 mW	680 mW
Differential Input Voltage (Note 2)	80V	68V
Input Voltage (Note 2)	±40V	±34V
Operating Temperature Range	-55°C to +125°C	0°C to +70°C
Storage Temperature Range	-65°C to +150°C	-65°C to +150°C
Output Short Circuit Duration	5 seconds	5 seconds
Lead Temperature (Soldering, 10 sec.)	300°C	300°C
ESD rating to be determined.		

Electrical Characteristics (Note 3)

Parameter	Conditions	LM143			LM343			Units
		Min	Typ	Max	Min	Typ	Max	
Input Offset Voltage	$T_A = 25^\circ\text{C}$		2.0	5.0		2.0	8.0	mV
Input Offset Current	$T_A = 25^\circ\text{C}$		1.0	3.0		1.0	10	nA
Input Bias Current	$T_A = 25^\circ\text{C}$		8.0	20		8.0	40	nA
Supply Voltage Rejection Ratio	$T_A = 25^\circ\text{C}$		10	100		10	200	$\mu\text{V}/\text{V}$
Output Voltage Swing	$T_A = 25^\circ\text{C}, R_L \geq 5\text{ k}\Omega$	22	25		20	25		V
Large Signal Voltage Gain	$T_A = 25^\circ\text{C}, V_{\text{OUT}} = \pm 10\text{V}, R_L \geq 100\text{ k}\Omega$	100k	180k		70k	180k		V/V
Common-Mode Rejection Ratio	$T_A = 25^\circ\text{C}$	80	90		70	90		dB
Input Voltage Range	$T_A = 25^\circ\text{C}$	±24	±26		±22	±26		V
Supply Current (Note 5)	$T_A = 25^\circ\text{C}$		2.0	4.0		2.0	5.0	mA
Short Circuit Current	$T_A = 25^\circ\text{C}$		20			20		mA
Slew Rate	$T_A = 25^\circ\text{C}, A_V = 1$		2.5			2.5		V/ μs
Power Bandwidth	$T_A = 25^\circ\text{C}, V_{\text{OUT}} = 40\text{ V}_{\text{p-p}}, R_L \geq 5\text{ k}\Omega, \text{THD} \leq 1\%$		20k			20k		Hz
Unity Gain Frequency	$T_A = 25^\circ\text{C}$		1.0M			1.0M		Hz
Input Offset Voltage	$T_A = \text{Max}$ $T_A = \text{Min}$			6.0 6.0			10 10	mV
Input Offset Current	$T_A = \text{Max}$ $T_A = \text{Min}$		0.8 1.8	4.5 7.0		0.8 1.8	14 14	nA
Input Bias Current	$T_A = \text{Max}$ $T_A = \text{Min}$		5.0 16	35 35		5.0 16	55 55	nA
Large Signal Voltage Gain	$R_L \geq 100\text{ k}\Omega, T_A = \text{Max}$ $R_L \geq 100\text{ k}\Omega, T_A = \text{Min}$	50k 50k	150k 220k		50k 50k	150k 220k		V/V
Output Voltage Swing	$R_L \geq 5.0\text{ k}\Omega, T_A = \text{Max}$ $R_L \geq 5.0\text{ k}\Omega, T_A = \text{Min}$	22 22	26 25		20 20	26 25		V

Note 1: Absolute maximum ratings are not necessarily concurrent, and care must be taken not to exceed the maximum junction temperature of the LM143 (150°C) or the LM343 (100°C). For operating at elevated temperatures, devices in the H08 package must be derated based on a thermal resistance of 155°C/W, junction to ambient, or 20°C/W, junction to case.

Note 2: For supply voltage less than ±40V for the LM143 and less than ±34V for the LM343, the absolute maximum input voltage is equal to the supply voltage.

Note 3: These specifications apply for $V_S = \pm 28\text{V}$. For LM143, $T_A = \text{max} = 125^\circ\text{C}$ and $T_A = \text{min} = -55^\circ\text{C}$. For LM343, $T_A = \text{max} = 70^\circ\text{C}$ and $T_A = \text{min} = 0^\circ\text{C}$.

Note 4: Refer to RETS143X for LM143H and LM1536H military specifications.

Note 5: The maximum supply currents are guaranteed at $V_S = \pm 40\text{V}$ for the LM143 and $V_S = \pm 34\text{V}$ for the LM343.

Schematic Diagram

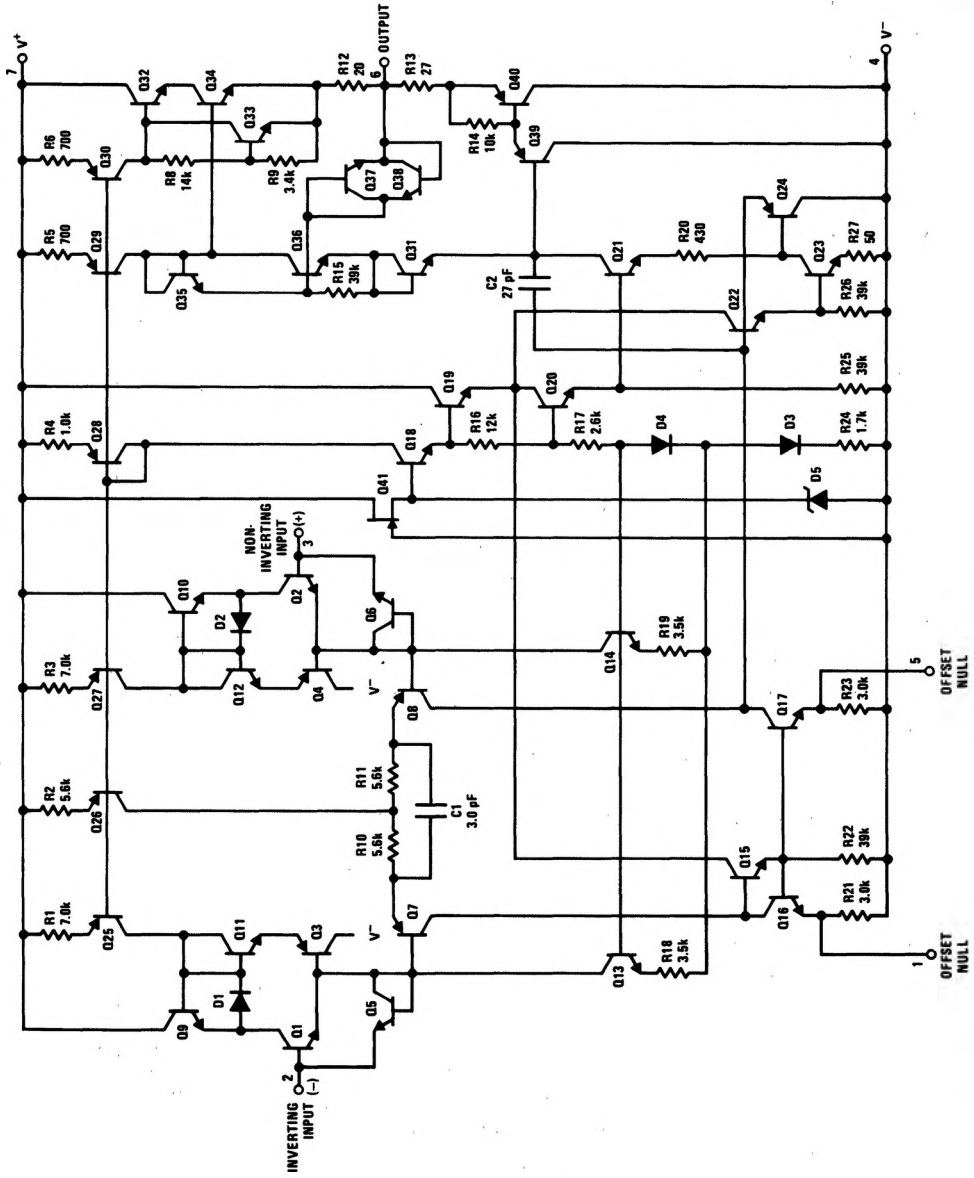

Typical Performance Characteristics

LM143/LM343

Voltage Follower Slew Rate

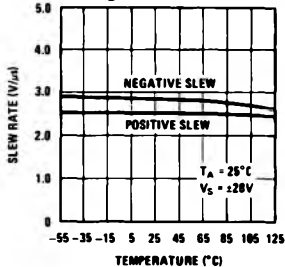

Supply Current

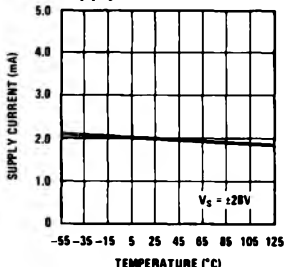

Short Circuit Current

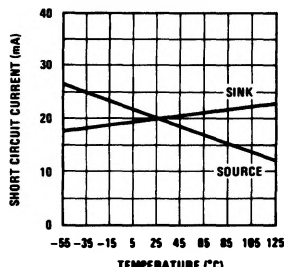

Unity Gain Bandwidth

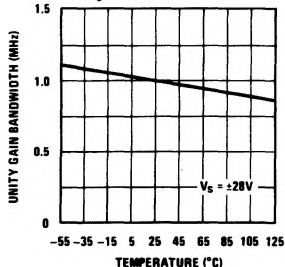

Input Noise Voltage

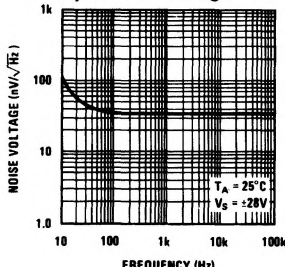

Input Noise Current

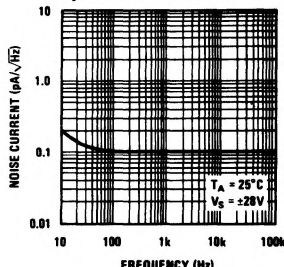

Common-Mode Rejection

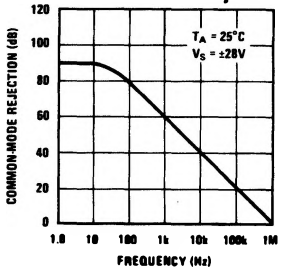

Power Supply Rejection

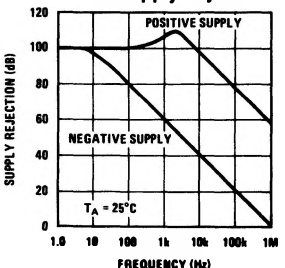

Large Signal Frequency Response

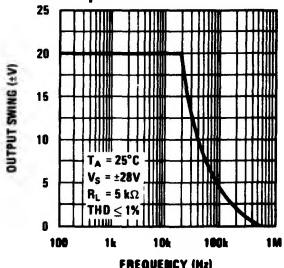

Open Loop Frequency Response

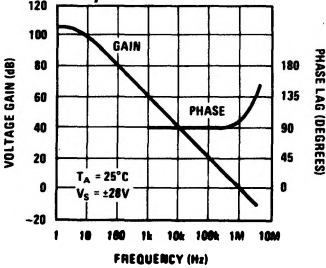

Voltage Follower Pulse Response

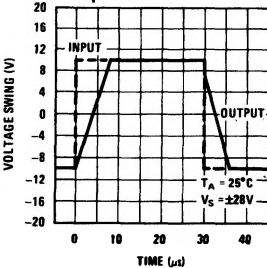

Inverter Pulse Response

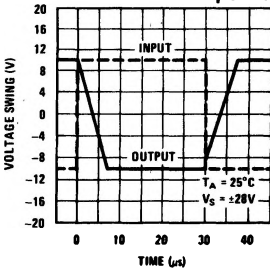

TL/H/7783-4

Typical Performance Characteristics (Continued)

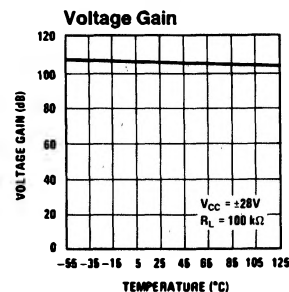
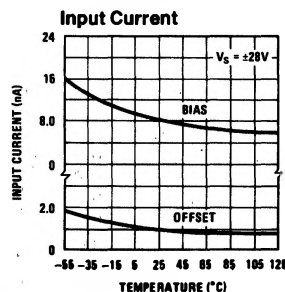
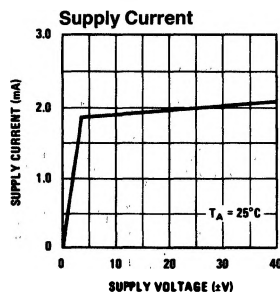
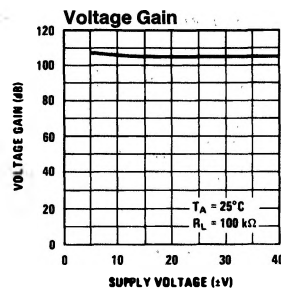
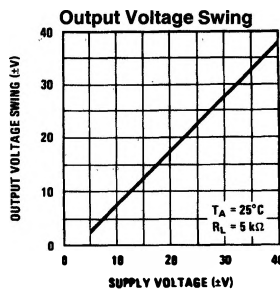
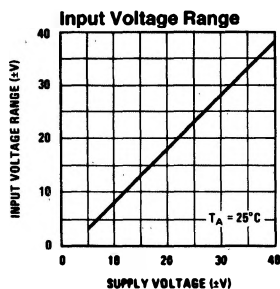

TL/H/7783-3

Application Hints (See AN-127)

The LM143 is designed for trouble free operation at any supply voltage up to and including the guaranteed maximum of $\pm 40\text{V}$. Input overvoltage protection, both common-mode and differential, is 100% tested and guaranteed at the maximum supply voltage. Furthermore, all possible high voltage destructive modes during supply voltage turn-on have been eliminated by design. As with most IC op amps, however, certain precautions should be observed to insure that the LM143 remains virtually blow-out proof.

Although output short circuits to ground or either supply can be sustained indefinitely at lower supply voltages, these short circuits should be of limited duration when operating at higher supply voltages. Units can be destroyed by any combination of high ambient temperature, high supply voltages, and high power dissipation which results in excessive die temperature. This is also true when driving low impedance or reactive loads or loads that can revert to low impedance; for example, the LM143 can drive most general purpose op amps outside of the maximum input voltage range, causing heavy current to flow and possibly destroying both devices.

Precautions should be taken to insure that the power supplies never become reversed in polarity—even under transient conditions. With reverse voltage, the IC will conduct excessive current, fusing the internal aluminum interconnects. Voltage reversal between the power supplies will almost always result in a destroyed unit.

In high voltage applications which are sensitive to very low input currents, special precautions should be exercised. For example, with high source resistances, care should be taken to prevent the magnitude of the PC board leakage currents, although quite small, from approaching those of the op amp input currents. These leakage currents become larger at 125°C and are made worse by high supply voltages. To prevent this, PC boards should be properly cleaned and coated to prevent contamination and to provide protection from condensed water vapor when operating below 0°C . A guard ring is also recommended to significantly reduce leakage currents from the op amp input pins to the adjacent high voltage pins in the standard op amp pin connection as shown in *Figure 1*. *Figures 2, 3* and *4* show how the guard ring is connected for the three most common op amp configurations.

Finally, caution should be exercised in high voltage applications as electrical shock hazards are present. Since the negative supply is connected to the case, users may inadvertently contact voltages equal to those across the power supplies.

The LM143 can be used as a plug-in replacement in most general purpose op amp applications. The circuits presented in the following section emphasize those applications which take advantage of the unique high voltage abilities of the LM143.

Application Hints (See AN-127) (Continued)

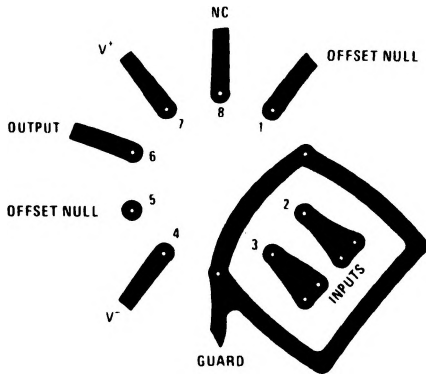

Bottom View

TL/H/7783-5

FIGURE 1. Printed Circuit Layout for Input Guarding with TO-5 Package

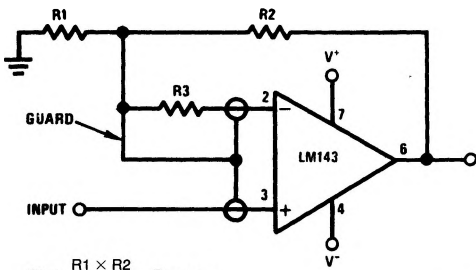

$$R3 + \frac{R1 \times R2}{R1 + R2} = R_{SOURCE}$$

TL/H/7783-7

FIGURE 3. Guarded Non-Inverting Amplifier

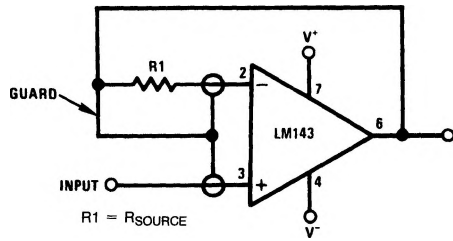
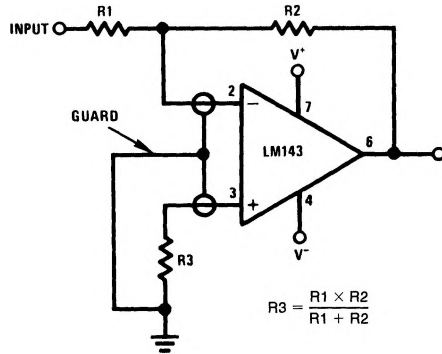

FIGURE 2. Guarded Voltage Follower

TL/H/7783-6



$$R3 = \frac{R1 \times R2}{R1 + R2}$$

TL/H/7783-8

FIGURE 4. Guarded Inverting Amplifier

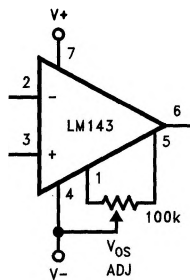

TL/H/7783-14

FIGURE 5. Offset Voltage Adjustment

Typical Applications ‡ (For more detail see AN-127)

130 V_{p-p} Drive Across a Floating Load

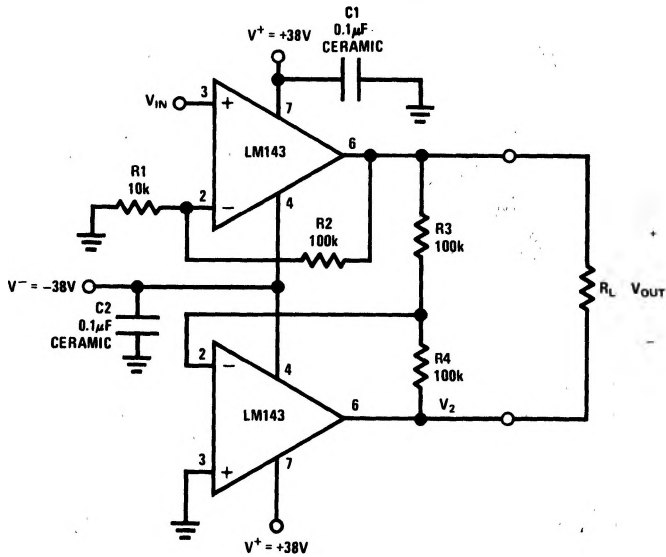

TL/H/7783-9

±34V Common-Mode Instrumentation Amplifier

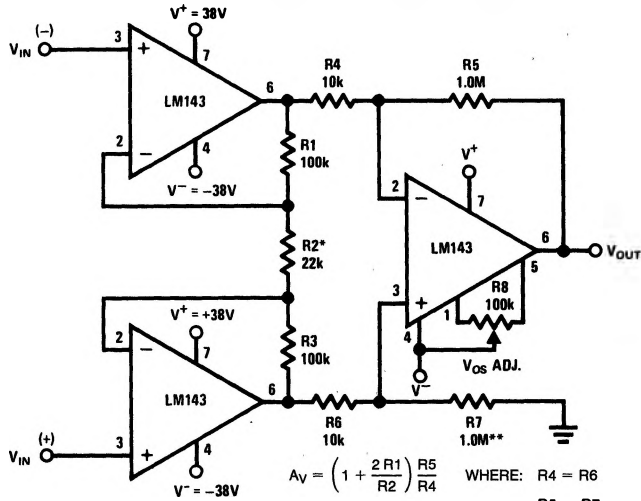

TL/H/7783-10

*R2 may be adjustable to trim the gain.

**R7 may be adjusted to compensate for the resistance tolerance of R4-R7 for best CMR.

‡The 38V supplies allow for a 5% voltage tolerance. All resistors are 1/2 watt, except as noted.

Typical Applications ‡ (Continued) (For more detail see AN-127)

Tracking $\pm 65V$, 1 Amp Power Supply with Short Circuit Protection

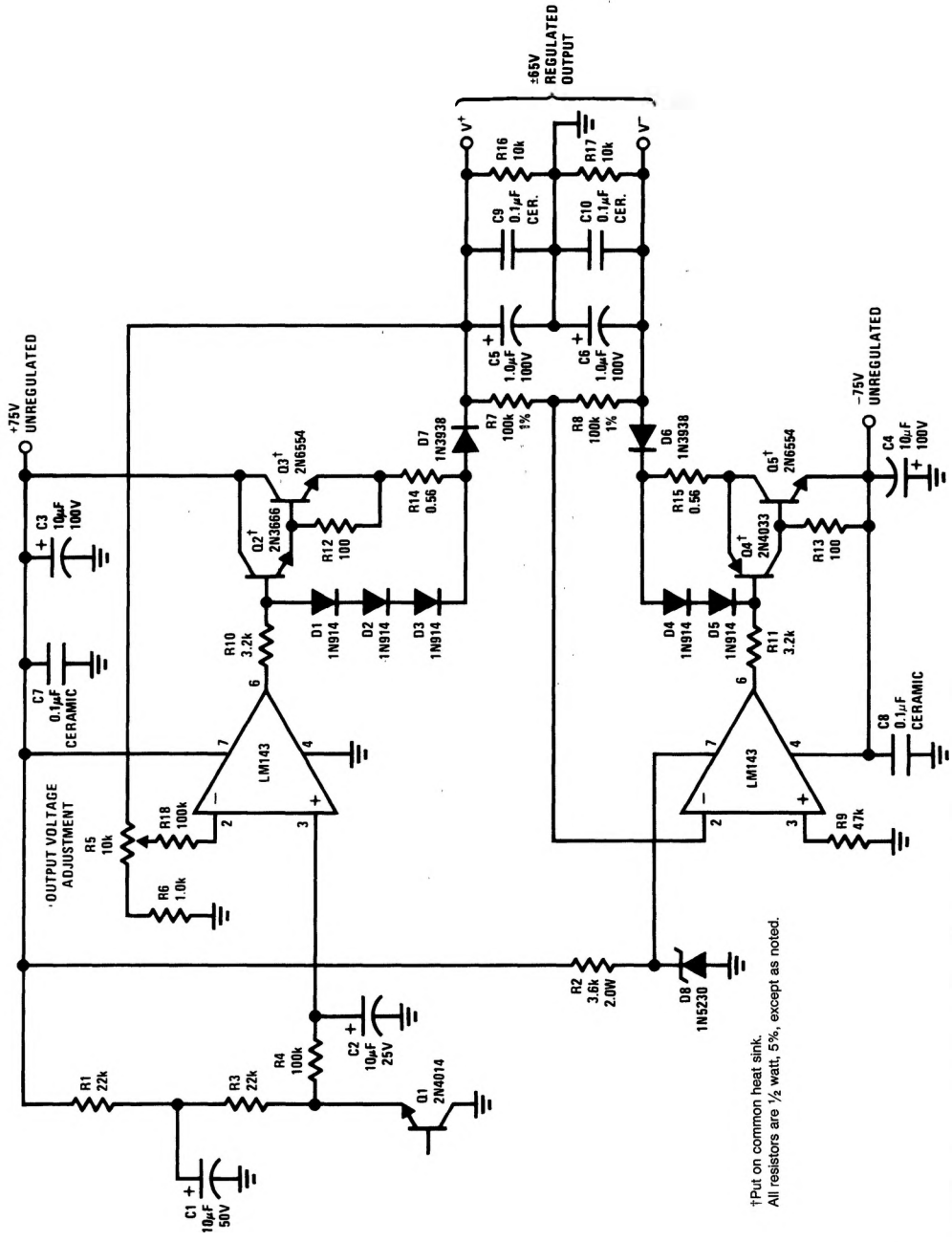

†Put on common heat sink.
All resistors are 1/2 watt, 5%, except as noted.

‡The 38V supplies allow for a 5% voltage tolerance. All resistors are 1/2 watt, except as noted.

Typical Applications ‡ (Continued) (For more detail see AN-127)

90W Audio Power Amplifier with Safe Area Protection

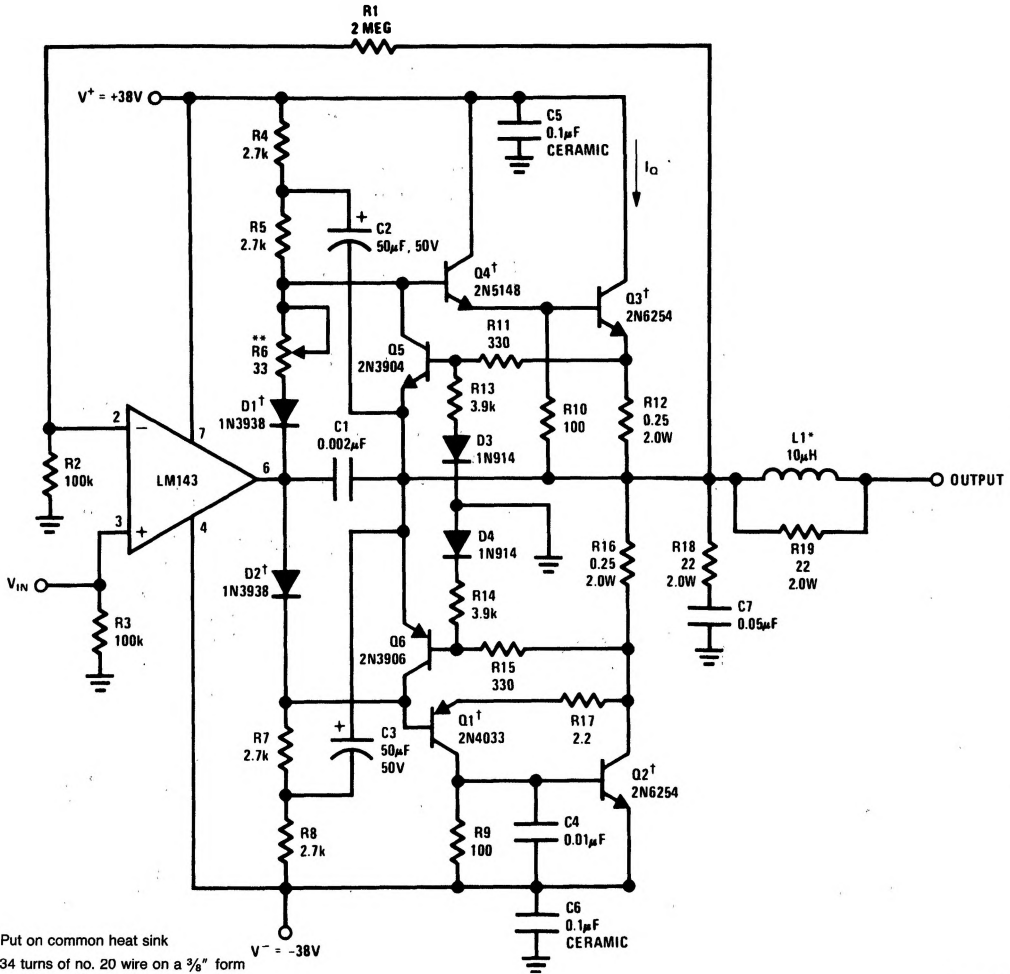

†Put on common heat sink
 *34 turns of no. 20 wire on a 3/8" form
 **Adjust R6 to set $I_Q = 100$ mA

TL/H/7783-12

‡The 38V supplies allow for a 5% voltage tolerance. All resistors are 1/2 watt, except as noted.

Typical Applications ‡ (Continued) (For more detail see AN-127)

1 Amp Power Amplifier with Short Circuit Protection

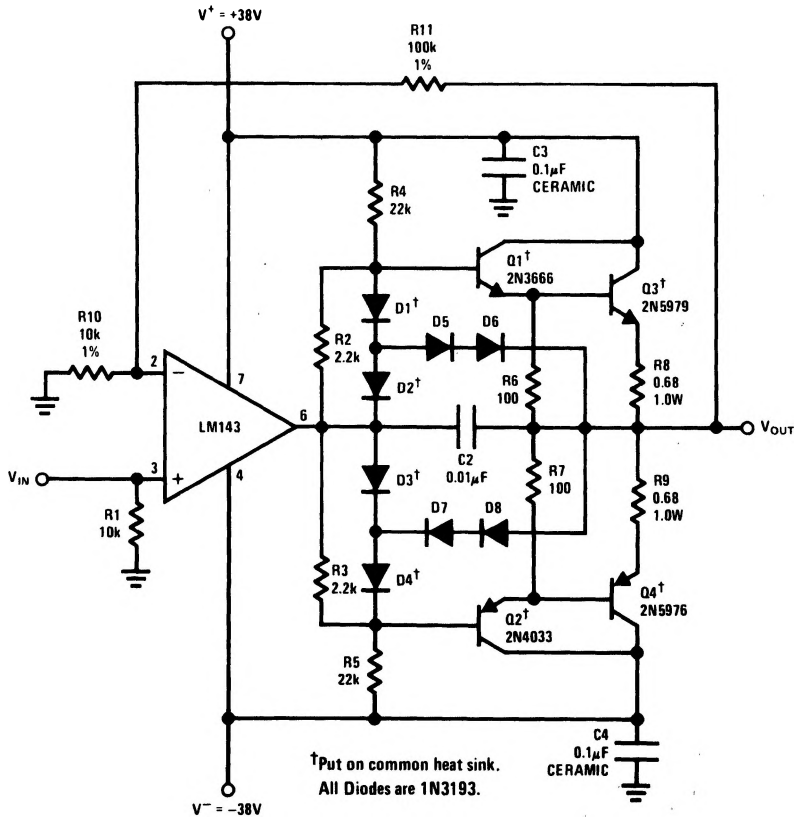

‡The 38V supplies allow for a 5% voltage tolerance. All resistors are 1/2 watt, except as noted.

TL/H/7783-13