

## LM1203 RGB Video Amplifier System

### General Description

The LM1203 is a wideband video amplifier system intended for high resolution RGB color monitor applications. In addition to three matched video amplifiers, the LM1203 contains three gated differential input black level clamp comparators for brightness control and three matched attenuator circuits for contrast control. Each video amplifier contains a gain set or "Drive" node for setting maximum system gain ( $A_v = 4$  to 10) as well as providing trim capability. The LM1203 also contains a voltage reference for the video inputs. For high resolution monochrome monitor applications see the LM1201 Video Amplifier System datasheet.

### Features

- Three wideband video amplifiers (70 MHz @ -3dB)
- Inherently matched ( $\pm 0.1$  dB or 1.2%) attenuators for contrast control
- Three externally gated comparators for brightness control
- Provisions for independent gain control (Drive) of each video amplifier
- Video input voltage reference
- Low impedance output driver

### Block and Connection Diagram

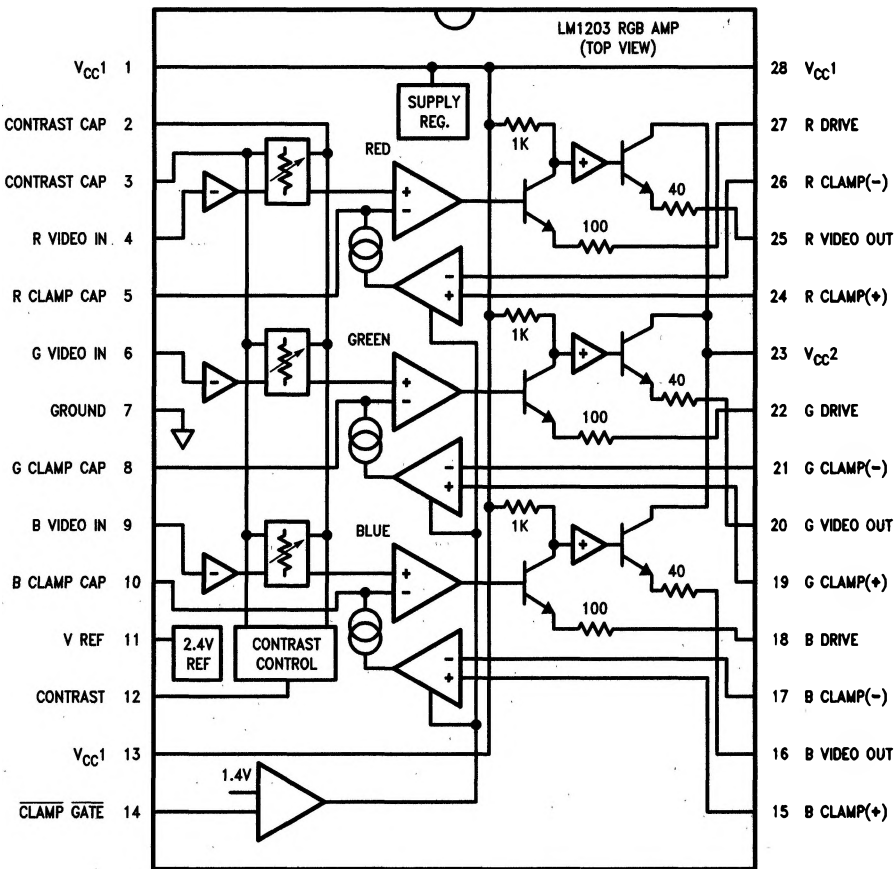

FIGURE 1  
Order Number LM1203N  
See NS Package Number N28B

TL/H/9178-1

## Absolute Maximum Ratings

If Military/Aerospace specified devices are required, please contact the National Semiconductor Sales Office/Distributors for availability and specifications.

Supply Voltage,  $V_{CC}$  Pins 1, 13, 23, 28  
(Note 1) 13.5V

Voltage at Any Input Pin,  $V_{IN}$   $V_{CC} \geq V_{IN} \geq GND$

Video Output Current, I16, 20 or 25 28 mA

Power Dissipation,  $P_D$  2.5W

(Above 25°C) Derate Based on  $\theta_{JA}$  and  $T_J$

Thermal Resistance,  $\theta_{JA}$  50°C/W

Junction Temperature,  $T_J$  150°C

Storage Temperature Range,  $T_{STG}$  -65°C to +150°C

Lead Temperature, (Soldering, 10 sec.) 265°C

ESD susceptibility 1 kV

Human body model: 100 pF discharged through a 1.5 k $\Omega$  resistor

## Operating Ratings (Note 9)

Temperature Range 0°C to 70°C

Supply Voltage ( $V_{CC}$ ) 10.8V  $\leq V_{CC} \leq$  13.2V

## Electrical Characteristics See Test Circuit (Figure 2), $T_A = 25^\circ\text{C}$ ; $V_{CC1} = V_{CC2} = 12\text{V}$

### DC Static Tests S17, 21, 26 Open; V12 = 6V; V14 = 0V; V15 = 2.0V unless otherwise stated

Label	Parameter	Conditions	Typ	Tested Limit (Note 2)	Design Limit (Note 3)	Units (Limits)
I <sub>s</sub>	Supply Current	$V_{CC}$ 1 only	73	90.0		mA(max)
V11	Video Input Reference Voltage		2.4	2.2		V(min)
				2.6		V(max)
I <sub>b</sub>	Video Input Bias Current	Any One Amplifier	5.0	20		$\mu\text{A}$ (max)
V14 l	Clamp Gate Low Input Voltage	Clamp Comparators On	1.2	0.8		V(max)
V14 h	Clamp Gate High Input Voltage	Clamp Comparators Off	1.6	2.0		V(min)
I14 l	Clamp Gate Low Input Current	V14 = 0V	-0.5	-5.0		$\mu\text{A}$ (max)
I14 h	Clamp Gate High Input Current	V14 = 12V	0.005	1		$\mu\text{A}$ (max)
I <sub>clamp+</sub>	Clamp Cap Charge Current	V5, 8 or 10 = 0V	850	500		$\mu\text{A}$ (min)
I <sub>clamp-</sub>	Clamp Cap Discharge Current	V5, 8 or 10 = 5V	-850	-500		$\mu\text{A}$ (min)
V <sub>ol</sub>	Video Output Low Voltage	V5, 8 or 10 = 0V	0.9	1.25		V(max)
V <sub>oh</sub>	Video Output High Voltage	V5, 8 or 10 = 5V	8.9	8.2		V(min)
$\Delta V_o(2V)$	Video Output Offset Voltage	Between Any Two Amplifiers V15 = 2V	$\pm 0.5$	$\pm 50$		mV(max)
$\Delta V_o(4V)$	Video Output Offset Voltage	Between Any Two Amplifiers V15 = 4V	$\pm 0.5$	$\pm 50$		mV(max)

### AC Dynamic Tests S17, 21, 26 Closed; V14 = 0V; V15 = 4V; unless otherwise stated

Symbol	Parameter	Conditions	Typ	Tested Limit (Note 2)	Design Limit (Note 3)	Units (Limits)
A <sub>v</sub> max	Video Amplifier Gain	V12 = 12V, $V_{IN} = 560$ mVp-p	6.0	4.5		V/V(min)
$\Delta A_v$ 5V	Attenuation @ 5V	Ref: A <sub>v</sub> max, V12 = 5V	-10			dB
$\Delta A_v$ 2V	Attenuation @ 2V	Ref: A <sub>v</sub> max, V12 = 2V	-40			dB
A <sub>v</sub> match	Absolute gain match @ A <sub>v</sub> max	V12 = 12V (Note 5)	$\pm 0.5$			dB
$\Delta A_v$ track1	Gain change between amplifiers	V12 = 5V (Notes 5, 8)	$\pm 0.1$		$\pm 0.5$	dB(max)
$\Delta A_v$ track2	Gain change between amplifiers	V12 = 2V (Notes 5, 8)	$\pm 0.3$		$\pm 0.7$	dB(max)
THD	Video Amplifier Distortion	V12 = 3V, $V_O = 1$ Vp-p	0.5			%
f (-3 dB)	Video Amplifier Bandwidth (Notes 4, 6)	V12 = 12V, $V_O = 100$ mV <sub>rms</sub>	70			MHz
t <sub>r</sub>	Output Rise Time (Note 4)	$V_O = 4$ Vp-p	5			ns
t <sub>f</sub>	Output Fall Time (Note 4)	$V_O = 4$ Vp-p	7			ns

## AC Dynamic Tests S17, 21, 26 Closed; V14 = 0V; V15 = 4V; unless otherwise stated (Continued)

Symbol	Parameter	Conditions	Typ	Tested Limit (Note 2)	Design Limit (Note 3)	Units
Vsep 10 kHz	Video Amplifier 10 kHz Isolation	V12 = 12V (Note 7)	-65			dB
Vsep 10 MHz	Video Amplifier 10 MHz Isolation	V12 = 12V (Notes 4, 7)	-46			dB

**Note 1:** V<sub>CC</sub> supply pins 1, 13, 23, 28 must be externally wired together to prevent internal damage during V<sub>CC</sub> power on/off cycles.

**Note 2:** These parameters are guaranteed and 100% production tested.

**Note 3:** Design limits are guaranteed (but not 100% production tested). These limits are not used to calculate outgoing quality levels.

**Note 4:** When measuring video amplifier bandwidth or pulse rise and fall times, a double sided full ground plane printed circuit board without socket is recommended. Video Amplifier 10 MHz isolation test also requires this printed circuit board.

**Note 5:** Measure gain difference between any two amplifiers. V<sub>IN</sub> = 1 Vp-p.

**Note 6:** Adjust input frequency from 10 kHz (A<sub>vmax</sub> ref level) to the -3 dB corner frequency (f - 3 dB).

**Note 7:** Measure output levels of the other two undriven amplifiers relative to driven amplifier to determine channel separation. Terminate the undriven amplifier inputs to simulate generator loading. Repeat test at f<sub>IN</sub> = 10 MHz for Vsep = 10 MHz.

**Note 8:** ΔAv track is a measure of the ability of any two amplifiers to track each other and quantifies the matching of the three attenuators. It is the difference in gain change between any two amplifiers with the Contrast Voltage V12 at either 5V or 2V measured relative to an Av max condition V12 = 12V. For example, at Av max the three amplifiers gains might be 17.4 dB, 16.9 dB, and 16.4 dB and change to 7.3 dB, 6.9 dB, and 6.5 dB respectively for V12 = 5V. This yields the measured typical ±0.1 dB channel tracking.

**Note 9:** Operating Ratings indicate conditions for which the device is functional. See Electrical Specifications for guaranteed performance limits.

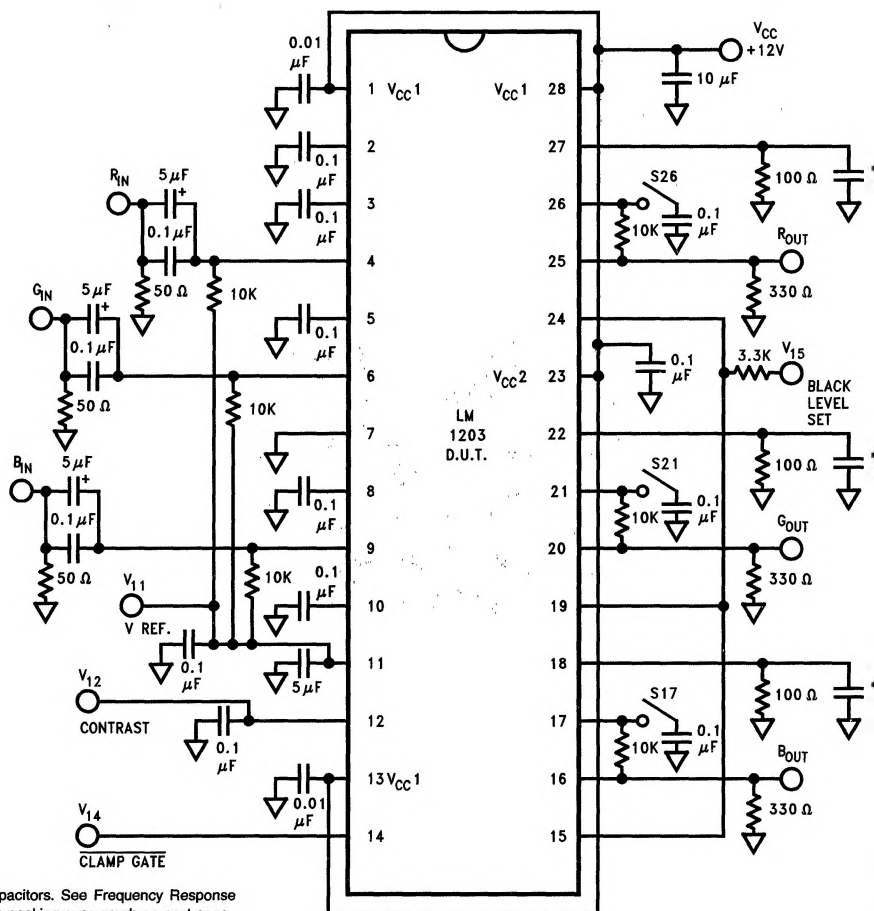

\*Peaking capacitors. See Frequency Response using various peaking cups graph on next page.

FIGURE 2. LM1203 Test Circuit

TL/H/9178-2

# Typical Performance Characteristics

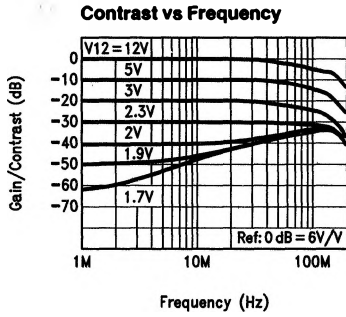

TL/H/9178-11

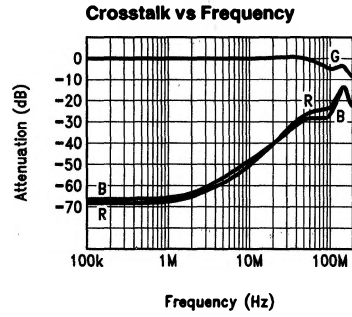

TL/H/9178-12

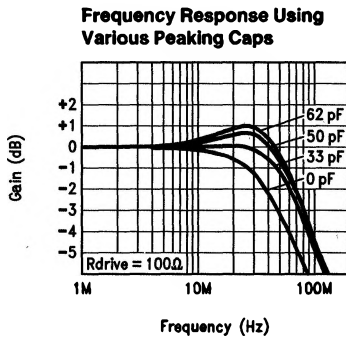

TL/H/9178-13

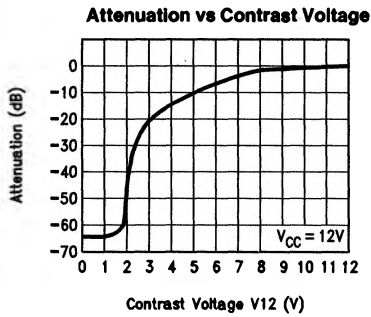

TL/H/9178-14

## Pulse Response

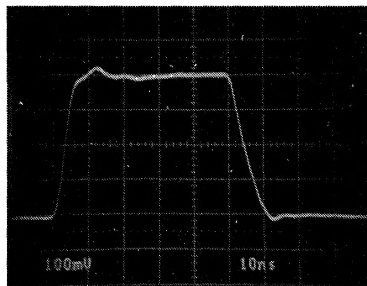

Rise & Fall Times  
Vert. = 1V/Div.  
Horiz. = 10 ns/Div.

-- GND  
TL/H/9178-15

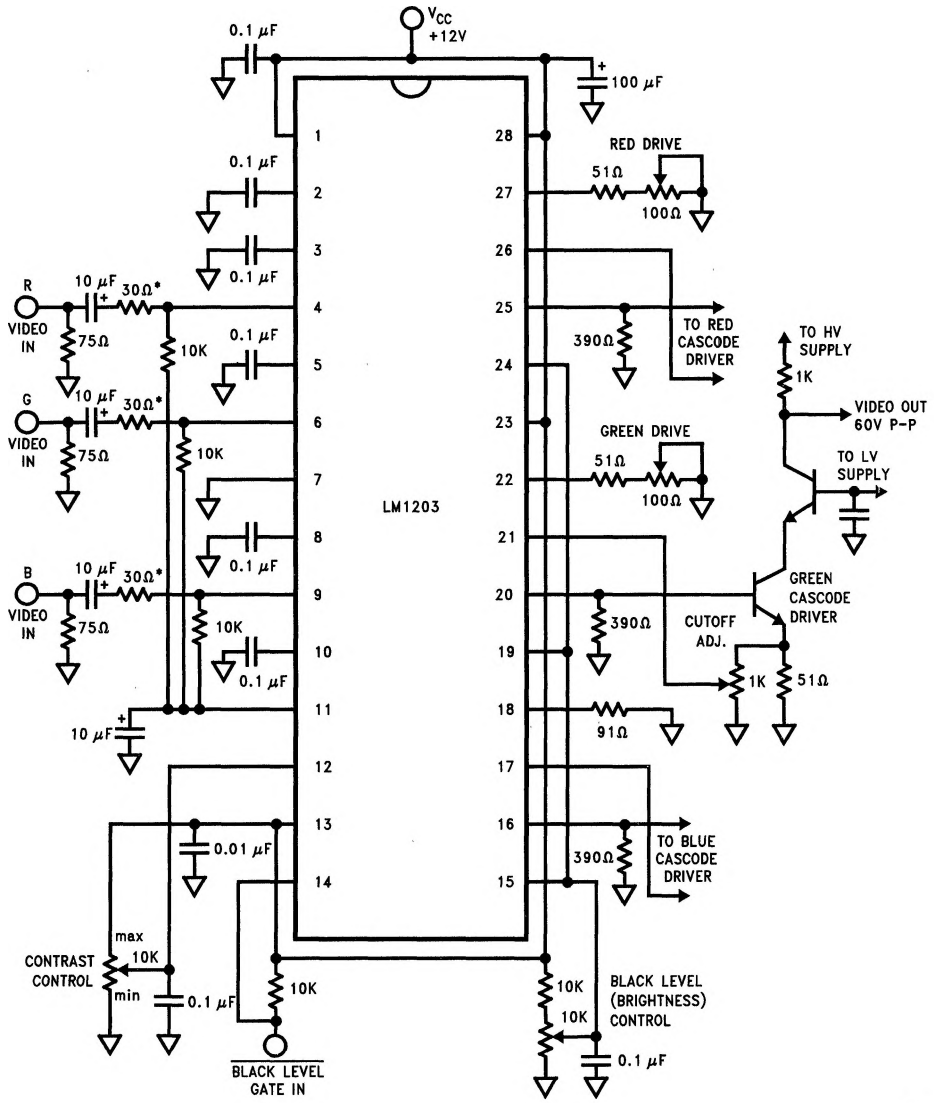

FIGURE 3. LM1203 Typical Application

TL/H/9178-3

\* 30Ω resistors are added to the input pins for protection against current surges coming through the 10 μF input capacitors. By increasing these resistors to well over 100Ω the rise and fall times of the LM1203 can be increased for EMI considerations.

## Applications Information

Figure 4 shows the block diagram of a typical analog RGB color monitor. The RGB monitor is used with CAD/CAM work stations, PC's, arcade games and in a wide range of other applications that benefit from the use of color display terminals. The RGB color monitor characteristics may differ in such ways as sweep rates, screen size, CRT color trio spacing (dot pitch), or in video amplifier bandwidths but will still be generally configured as shown in Figure 4. Separate horizontal and vertical sync signals may be required or they may be contained in the green video input signal. The video input signals are usually supplied by coax cable which is terminated in  $75\Omega$  at the monitor input and internally ac cou-

pled to the video amplifiers. These input signals are approximately 1 volt peak to peak in amplitude and at the input of the high voltage video section, approximately 6V peak to peak. At the cathode of the CRT the video signals can be as high as 60V peak to peak. One important requirement of the three video amplifiers is that they match and track each other over the contrast and brightness control range. The Figure 4 block labeled "VIDEO AMPLIFICATION WITH GAIN AND DC CONTROL" describes the function of the LM1203 which contains the three matched video amplifiers, contrast control and brightness control.

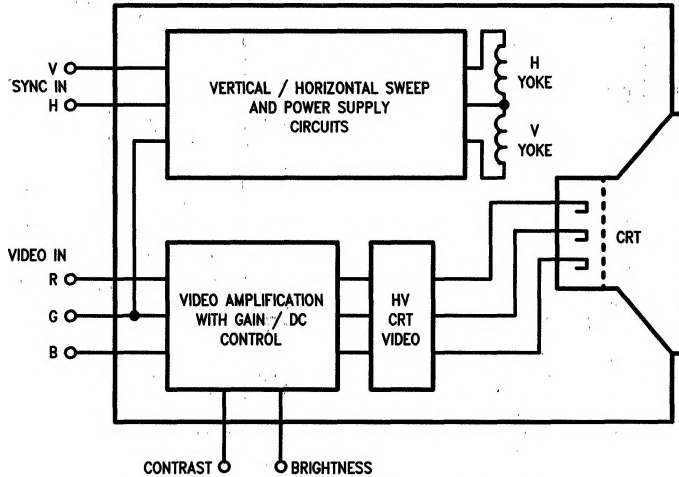

FIGURE 4. Typical RGB Color Monitor Block Diagram

TL/H/9178-4

### Circuit Description

Figure 5 is a block diagram of one of the video amplifiers along with the contrast and brightness controls. The contrast control is a dc-operated attenuator which varies the ac gain of all three amplifiers simultaneously while not introducing any signal distortions or tracking errors. The brightness control function requires a "sample and hold" circuit (black level clamp) which holds the dc bias of the video amplifiers and CRT cathodes constant during the black level reference portion of the video waveform. The clamp comparator, when gated on during this reference period, will charge or discharge the clamp capacitor until the plus input of the clamp comparator matches that of the minus input voltage which was set by the brightness control.

Figure 6 is a simplified schematic of one of the three video amplifiers along with the recommended external components. The IC pin numbers are circled with all external components shown outside of the dashed line. The video input is applied to pin 6 via the 10  $\mu$ F coupling capacitor. DC bias

to the video input is through the 10 k $\Omega$  resistor which is connected to the 2.4V reference at pin 11. The low frequency roll-off of the amplifier is set by these two components. Transistor Q1 buffers the video signal to the base of Q2. The Q2 collector current is then directed to the V<sub>CC</sub> 1 supply directly or through the 1k load resistor depending upon the differential DC voltage at the bases of Q3 and Q4. The Q3 and Q4 differential base voltage is determined by the contrast control circuit which is described below. RF decoupling capacitors are required at pins 2 and 3 to insure high frequency isolation between the three video amplifiers which share these common connections. The black level dc voltage at the collector of Q4 is maintained by Q5 and Q6 which are part of the black level clamp circuit also described below. The video signal appearing at the collector of Q4 is then buffered by Q7 and level shifted down by Z1 and Q8 to the base of Q9 which will then provide additional system gain.

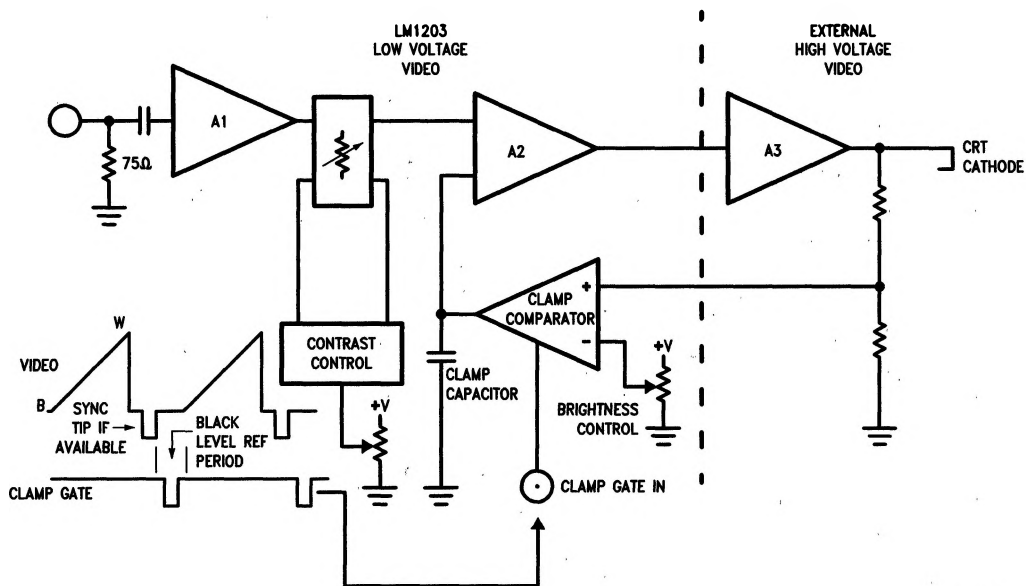

FIGURE 5. Block Diagram of LM1203 Video Amplifier with Contrast and Black Level Control

TL/H/9178-5

Circuit Description (Continued)

TL/H/9178-6

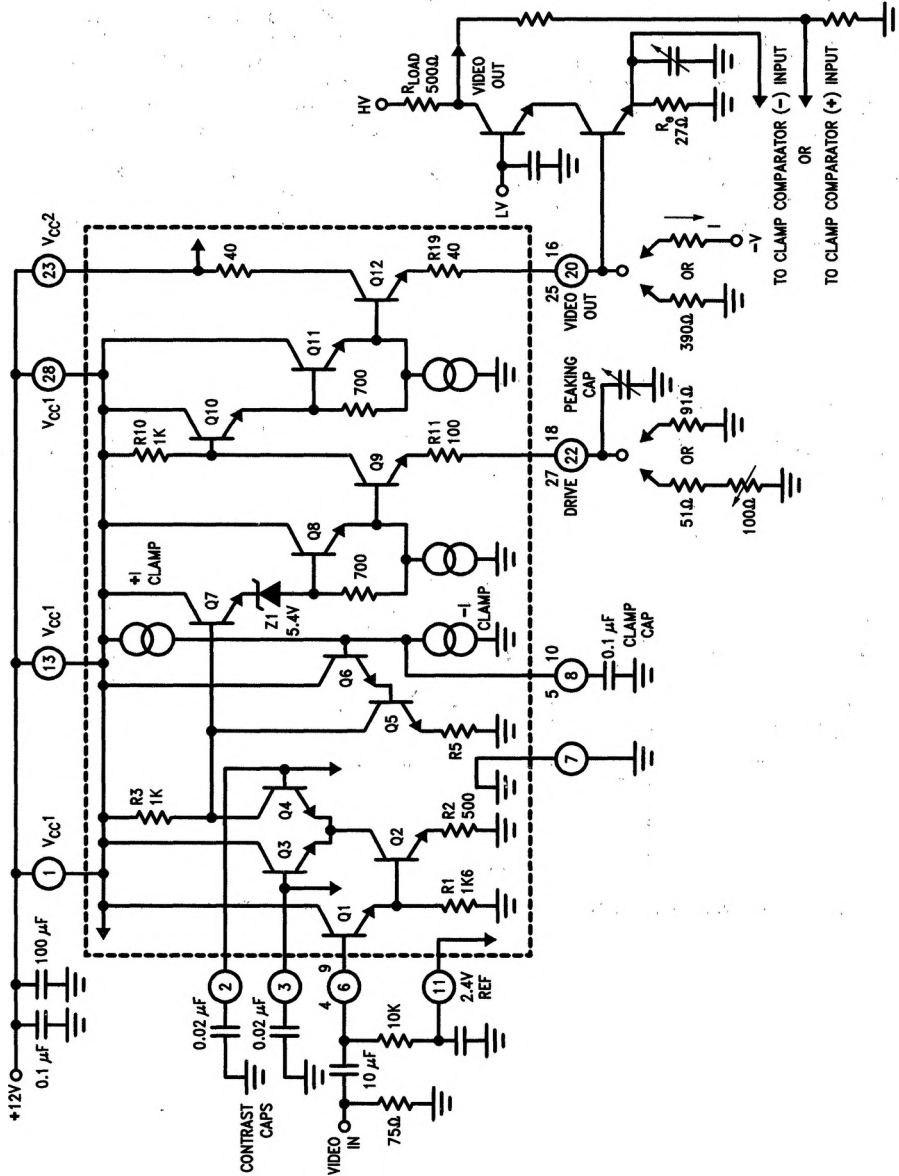

FIGURE 6. Simplified LM1203 Video Amplifier Section with Recommended External Components

## Circuit Description (Continued)

The "Drive" pin will allow the user to trim the Q9 gain of each amplifier to correct for differences in the CRT and high voltage cathode driver gain stages. A small capacitor (33 pF) at this pin will extend the high frequency gain of the video amplifier by compensating for some of the internal high frequency roll off. To use this capacitor and still provide variable gain adjustment, the 51Ω and series 100Ω pot should be used with the red and green drive pins. The 91Ω resistor used with the blue drive pin will set the system gain to approximately 6.2 and allow adjustment of the red and green gains to 6.2 plus or minus 25%. The video signal at the collector of Q9 is buffered and level shifted down by Q10 and Q11 to the base of the output emitter follower Q12. Between the emitter of Q12 and the video output pin is a 40Ω resistor which was included to prevent spurious oscillations when driving capacitive loads. An external emitter resistor must be added between the video output pin and ground. The value of this resistor should not be less than 390Ω or package power limitations may be exceeded when worst case (high supply, max supply current, max temp) calculations are made. If negative going pulse slewing is a problem because of high capacitive loads (>10 pF), a more efficient method of emitter pull down would be to connect a suitable resistor to a negative supply voltage. This has the effect of a current source pull down when the minus supply voltage is -12V and the emitter current is approximately

10 mA. The system gain will also increase slightly because less signal will be lost across the internal 40Ω resistor. Precautions must be taken to prevent the video output pin from going below ground because IC substrate currents may cause erratic operation. The collector currents from the video output transistors are returned to the power supply at V<sub>CC</sub> 2 pin 23. When making power dissipation calculations note that the data sheet specifies only the V<sub>CC</sub> 1 supply current at 12V. The IC power dissipation contribution of V<sub>CC</sub> 2 is dependent upon the video output emitter pull down load.

In applications that require video amplifier shut down because of fault conditions detected by monitor protection circuits, pin 11 and the wiper arms of the contrast and brightness controls can be grounded without harming the IC. This assumes some series resistance between the top of the control pots and V<sub>CC</sub>.

Figure 7 shows the internal construction of the pin 11 2.4V reference circuit which is used to provide temperature and supply voltage tracking compensation for the video amplifier inputs. The value of the external DC biasing resistors should not be larger than 10 kΩ because minor differences in input bias currents to the individual video amplifiers may cause offsets in gain.

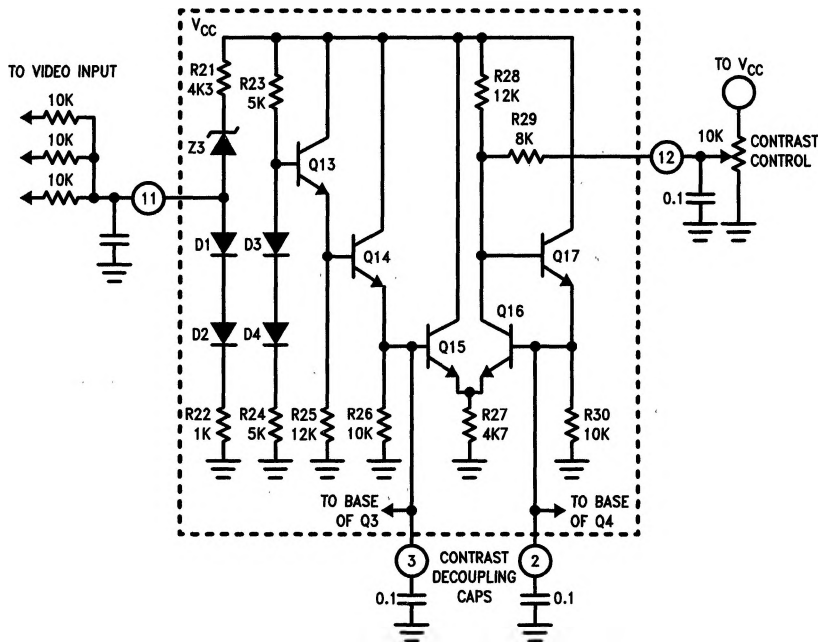

FIGURE 7. LM1203 Video Input Voltage Reference and Contrast Control Circuits

TL/H/9178-7



## Additional Applications of the LM1203

Figure 9 shows how the LM1203 can be set up as a video buffer which could be used in low cost video switcher applications. Pin 14 is tied high to turn off the clamp comparators. The comparator input pins should be grounded as shown. Sync tip (black level if sync is not included) clamping is provided by diodes at the amplifier inputs. Note that the clamp cap pins are tied to the Pin 11 2.4V reference. This was done, along with the choice of 200Ω for the drive pin resistor, to establish an optimum DC output voltage. The

contrast control (Pin 12) will provide the necessary gain or attenuation required for channel balancing. Changing the contrast control setting will cause minor DC shifts at the amplifier output which will not be objectionable as the output is AC coupled to the load. The dual NPN/PNP emitter follower will provide a low impedance output drive to the AC coupled 75Ω output impedance setting resistor. The dual 500 μF capacitors will set the low frequency response to approximately 4 Hz.

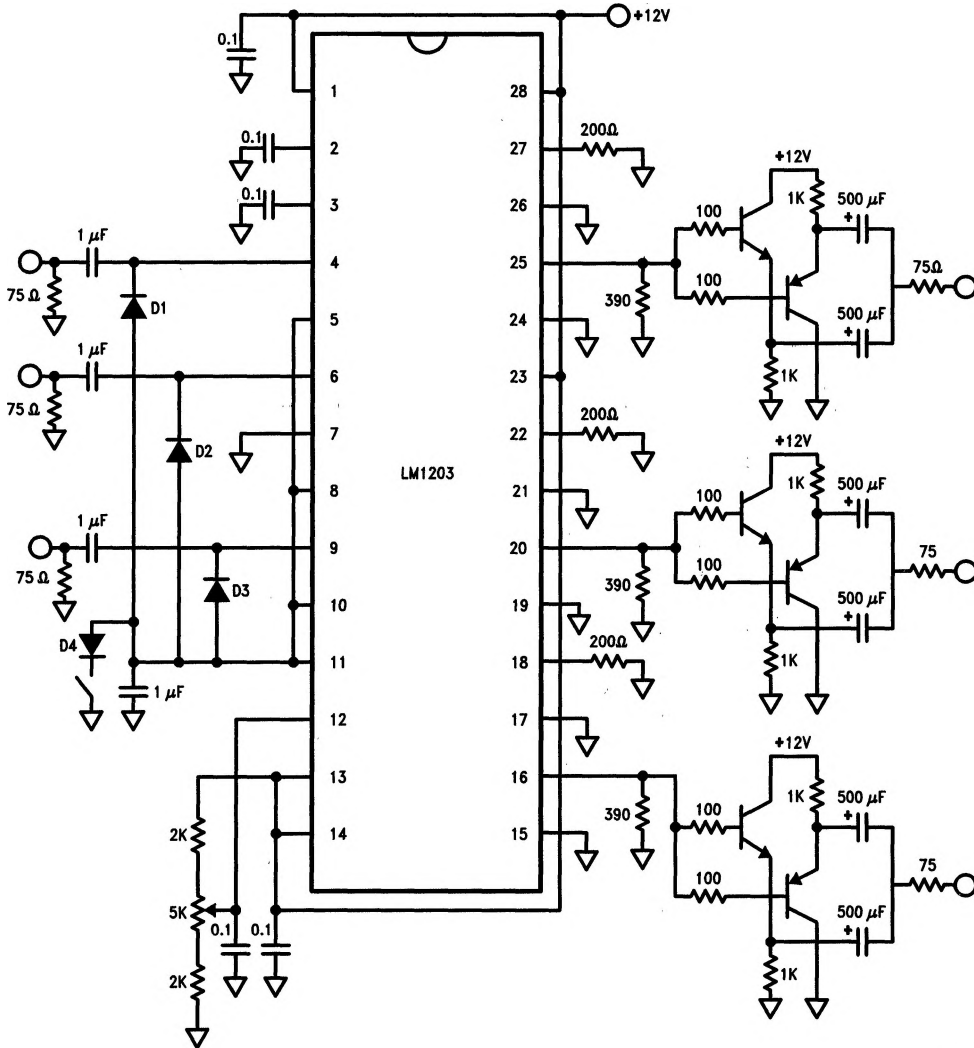

FIGURE 9. RGB Video Buffer with Diode Sync Tip Clamps and 75Ω Cable Driver

TL/H/9178-9

## Additional Applications of the LM1203 (Continued)

When diode D4 at Pin 11 is switched to ground the input video signals will be DC shifted down and clamped at a voltage near ground (approximately 250 mV). This will disable the video amplifiers and force the output DC level low. The DC outputs from other similarly configured LM1203s could override this lower DC level and provide the output signals to the 75 $\Omega$  cable drivers. In this case any additional LM1203s would share the same 390 $\Omega$  output resistor. The maximum DC plus peak white output voltage should not be allowed to exceed 7V because the "off" amplifier output stage could suffer internal zener damage. See Figure 3 and text for a description of the internal configuration of the video amplifier.

Figure 10 shows the configuration for a three channel high frequency amplifier with non gated DC feedback. Pin 14 is tied low to turn on the clamp comparators (feedback amplifiers). The inverting inputs (Pins 17, 21, 26) are connected to the amplifier outputs from a low pass filter. Additional low frequency filtering is provided by the clamp caps. The drive resistors can be made variable or fixed at values between 0 and 300 $\Omega$ . Maximum output swings are achieved when the DC output is set to approximately 4V. The high frequency response will be dependent upon external peaking at the drive pins.

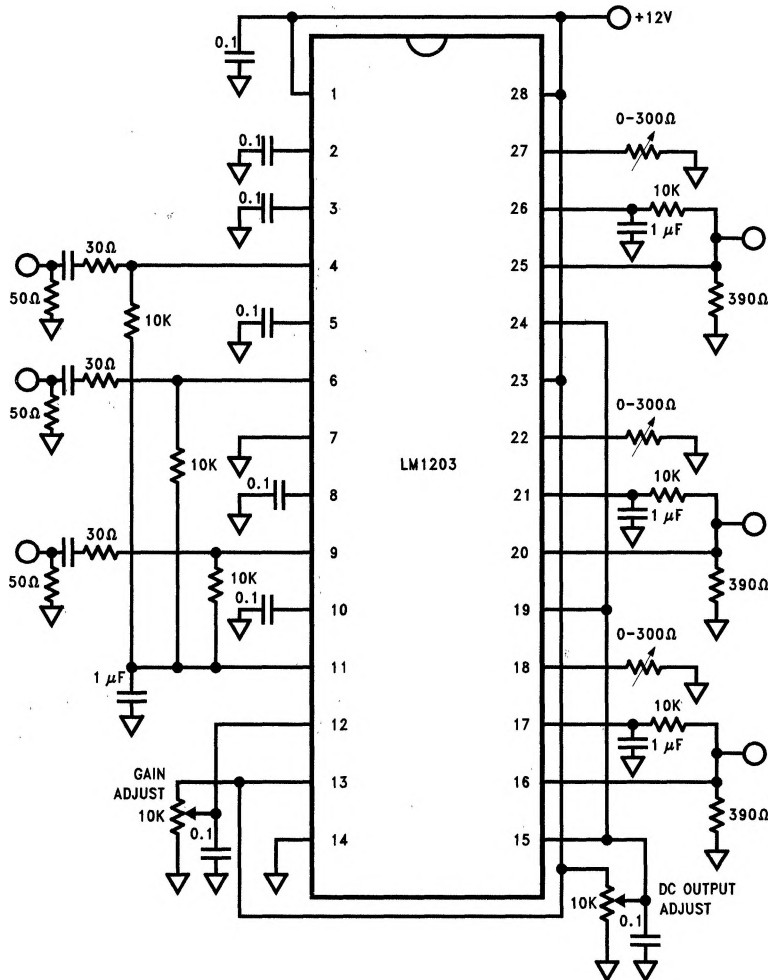

FIGURE 10. Three Channel High Frequency Amplifier with Non-gated DC Feedback (Non-video Applications)

TL/H/9178-10

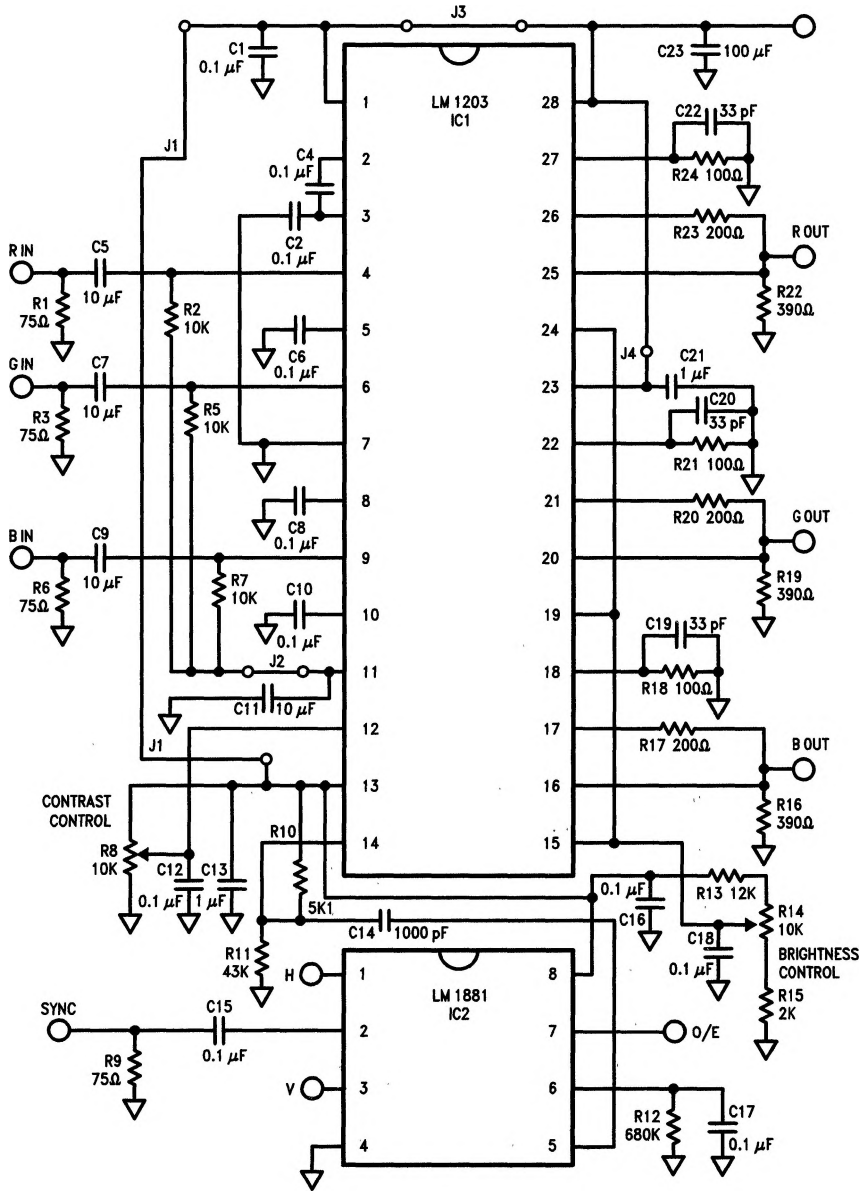

FIGURE 11. LM1203/LM1881 Application Circuit for PC Board

TL/H/9178-16

PC Board with Components

