

## LM118/LM218/LM318 Operational Amplifiers

 Check for Samples: [LM118-N](#), [LM218-N](#), [LM318-N](#)

### FEATURES

- 15 MHz small signal bandwidth
- Guaranteed 50V/μs slew rate
- Maximum bias current of 250 nA
- Operates from supplies of ±5V to ±20V
- Internal frequency compensation
- Input and output overload protected
- Pin compatible with general purpose op amps

### DESCRIPTION

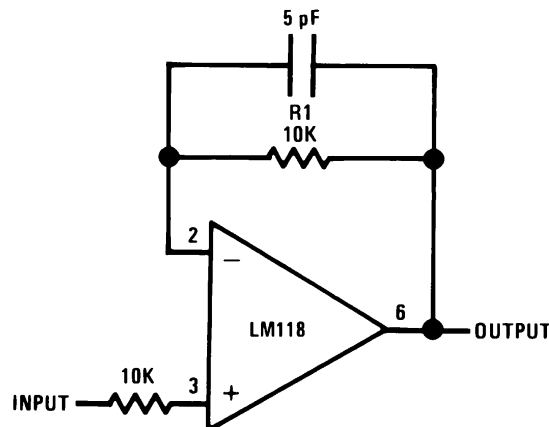
The LM118 series are precision high speed operational amplifiers designed for applications requiring wide bandwidth and high slew rate. They feature a factor of ten increase in speed over general purpose devices without sacrificing DC performance.

The LM118 series has internal unity gain frequency compensation. This considerably simplifies its application since no external components are necessary for operation. However, unlike most internally compensated amplifiers, external frequency compensation may be added for optimum performance. For inverting applications, feedforward compensation will boost the slew rate to over 150V/μs and almost double the bandwidth. Overcompensation can be used with the amplifier for greater stability when maximum bandwidth is not needed. Further, a single capacitor can be added to reduce the 0.1% settling time to under 1 μs.

The high speed and fast settling time of these op amps make them useful in A/D converters, oscillators, active filters, sample and hold circuits, or general purpose amplifiers. These devices are easy to apply and offer an order of magnitude better AC performance than industry standards such as the LM709.

The LM218 is identical to the LM118 except that the LM218 has its performance specified over a -25°C to +85°C temperature range. The LM318 is specified from 0°C to +70°C.

### Fast Voltage Follower



Do not hard-wire as voltage follower ( $R1 \geq 5 \text{ k}\Omega$ )



Please be aware that an important notice concerning availability, standard warranty, and use in critical applications of Texas Instruments semiconductor products and disclaimers thereto appears at the end of this data sheet.

All trademarks are the property of their respective owners.



These devices have limited built-in ESD protection. The leads should be shorted together or the device placed in conductive foam during storage or handling to prevent electrostatic damage to the MOS gates.

### Absolute Maximum Ratings<sup>(1)(2)</sup>

Supply Voltage	±20V
Power Dissipation <sup>(3)</sup>	500 mW
Differential Input Current <sup>(4)</sup>	±10 mA
Input Voltage <sup>(5)</sup>	±15V
Output Short-Circuit Duration	Continuous
Operating Temperature Range	
LM118	–55°C to +125°C
LM218	–25°C to +85°C
LM318	0°C to +70°C
Storage Temperature Range	–65°C to +150°C
Lead Temperature (Soldering, 10 sec.)	
TO-99 Package	300°C
PDIP Package	260°C
Soldering Information	
Dual-In-Line Package	
Soldering (10 sec.)	260°C
SOIC Package	
Vapor Phase (60 sec.)	215°C
Infrared (15 sec.)	220°C
See AN-450 "Surface Mounting Methods and Their Effect on Product Reliability" for other methods of soldering surface mount devices.	
ESD Tolerance <sup>(6)</sup>	2000V

- (1) Refer to RETS118X for LM118H and LM118J military specifications.
- (2) If Military/Aerospace specified devices are required, please contact the TI Sales Office/Distributors for availability and specifications.
- (3) The maximum junction temperature of the LM118 is 150°C, the LM218 is 110°C, and the LM318 is 110°C. For operating at elevated temperatures, devices in the LMC package must be derated based on a thermal resistance of 160°C/W, junction to ambient, or 20°C/W, junction to case. The thermal resistance of the dual-in-line package is 100°C/W, junction to ambient.
- (4) The inputs are shunted with back-to-back diodes for overvoltage protection. Therefore, excessive current will flow if a differential input voltage in excess of 1V is applied between the inputs unless some limiting resistance is used.
- (5) For supply voltages less than ±15V, the absolute maximum input voltage is equal to the supply voltage.
- (6) Human body model, 1.5 kΩ in series with 100 pF.

### Electrical Characteristics<sup>(1)</sup>

Parameter	Conditions	LM118/LM218			LM318			Units
		Min	Typ	Max	Min	Typ	Max	
Input Offset Voltage	T <sub>A</sub> = 25°C		2	4		4	10	mV
Input Offset Current	T <sub>A</sub> = 25°C		6	50		30	200	nA
Input Bias Current	T <sub>A</sub> = 25°C		120	250		150	500	nA
Input Resistance	T <sub>A</sub> = 25°C	1	3		0.5	3		MΩ
Supply Current	T <sub>A</sub> = 25°C		5	8		5	10	mA
Large Signal Voltage Gain	T <sub>A</sub> = 25°C, V <sub>S</sub> = ±15V V <sub>OUT</sub> = ±10V, R <sub>L</sub> ≥ 2 kΩ	50	200		25	200		V/mV
Slew Rate	T <sub>A</sub> = 25°C, V <sub>S</sub> = ±15V, A <sub>V</sub> = 1 (2)	50	70		50	70		V/μs
Small Signal Bandwidth	T <sub>A</sub> = 25°C, V <sub>S</sub> = ±15V		15			15		MHz
Input Offset Voltage				6			15	mV

- (1) These specifications apply for ±5V ≤ V<sub>S</sub> ≤ ±20V and –55°C ≤ T<sub>A</sub> ≤ +125°C (LM118), –25°C ≤ T<sub>A</sub> ≤ +85°C (LM218), and 0°C ≤ T<sub>A</sub> ≤ +70°C (LM318). Also, power supplies must be bypassed with 0.1 μF disc capacitors.
- (2) Slew rate is tested with V<sub>S</sub> = ±15V. The LM118 is in a unity-gain non-inverting configuration. V<sub>IN</sub> is stepped from –7.5V to +7.5V and vice versa. The slew rates between –5.0V and +5.0V and vice versa are tested and guaranteed to exceed 50V/μs.

**Electrical Characteristics <sup>(1)</sup> (continued)**

Parameter	Conditions	LM118/LM218			LM318			Units
		Min	Typ	Max	Min	Typ	Max	
Input Offset Current				100			300	nA
Input Bias Current				500			750	nA
Supply Current	$T_A = 125^\circ\text{C}$		4.5	7				mA
Large Signal Voltage Gain	$V_S = \pm 15\text{V}$ , $V_{OUT} = \pm 10\text{V}$ $R_L \geq 2\text{ k}\Omega$	25			20			V/mV
Output Voltage Swing	$V_S = \pm 15\text{V}$ , $R_L = 2\text{ k}\Omega$	$\pm 12$	$\pm 13$		$\pm 12$	$\pm 13$		V
Input Voltage Range	$V_S = \pm 15\text{V}$	$\pm 11.5$			$\pm 11.5$			V
Common-Mode Rejection Ratio		80	100		70	100		dB
Supply Voltage Rejection Ratio		70	80		65	80		dB

TYPICAL PERFORMANCE CHARACTERISTICS

LM118, LM218

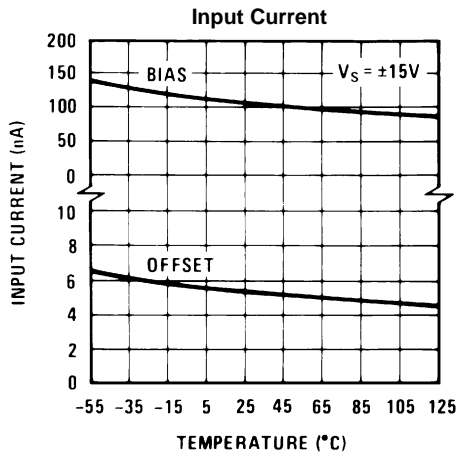


Figure 1.

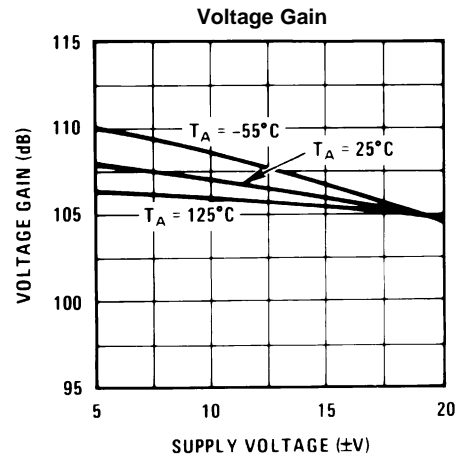


Figure 2.

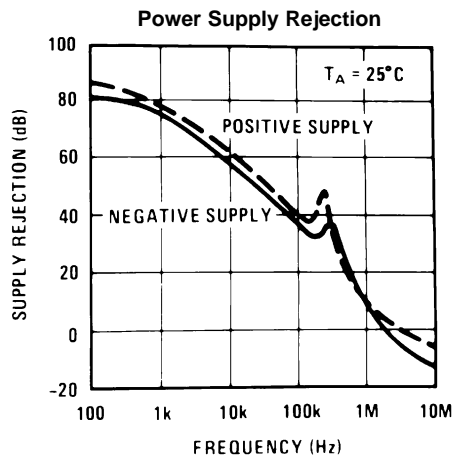


Figure 3.

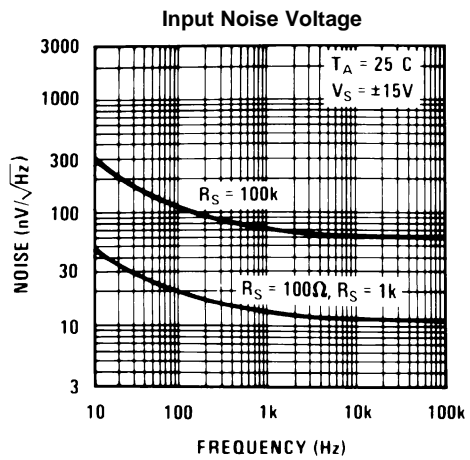


Figure 4.

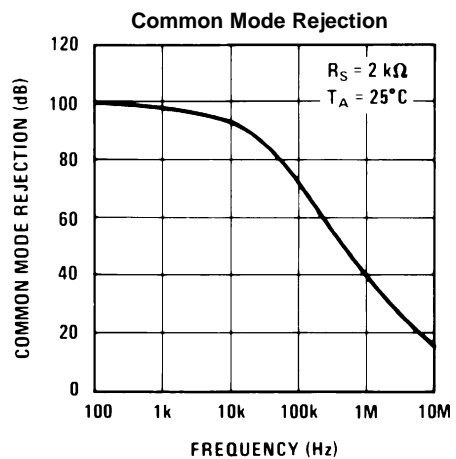


Figure 5.

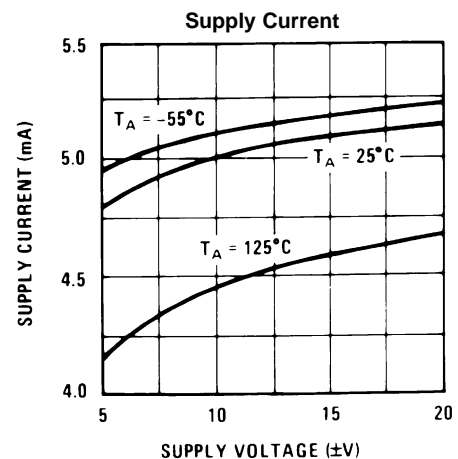


Figure 6.

TYPICAL PERFORMANCE CHARACTERISTICS (continued)

LM118, LM218

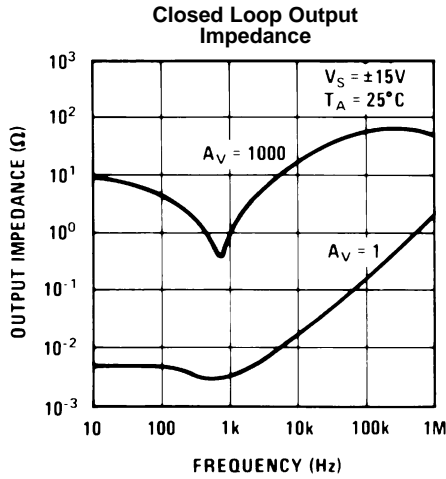


Figure 7.

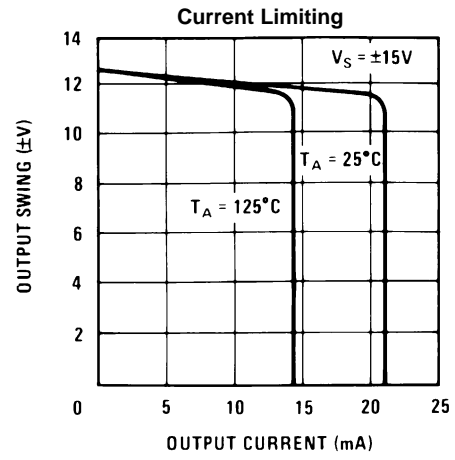


Figure 8.

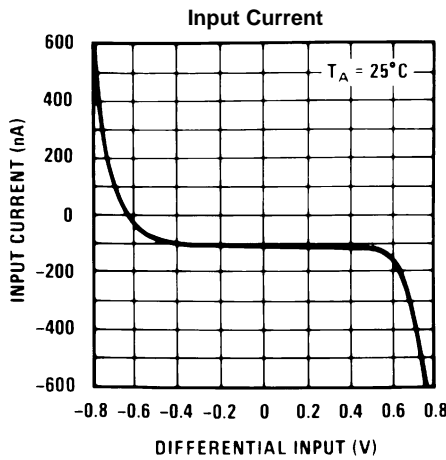


Figure 9.

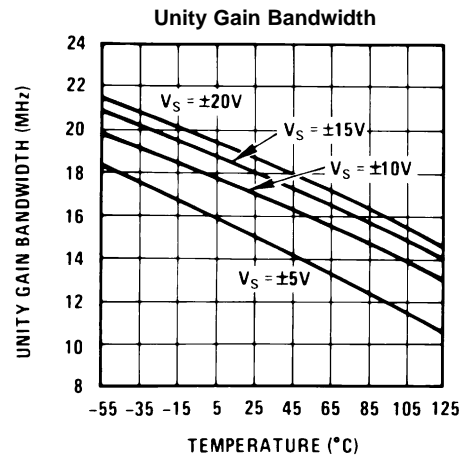


Figure 10.

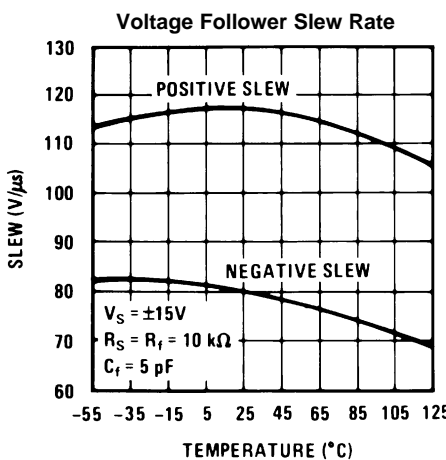


Figure 11.

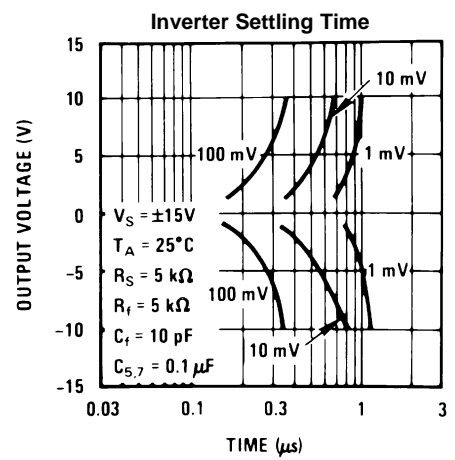


Figure 12.

TYPICAL PERFORMANCE CHARACTERISTICS (continued)

LM118, LM218

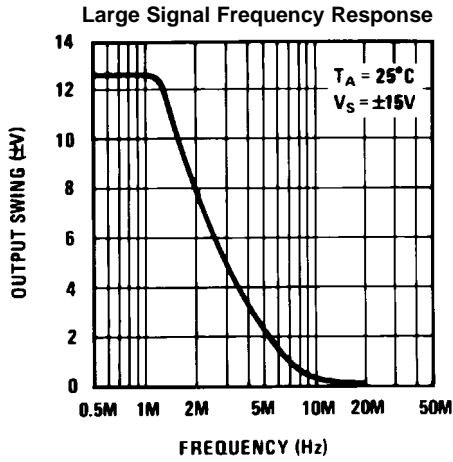


Figure 13.

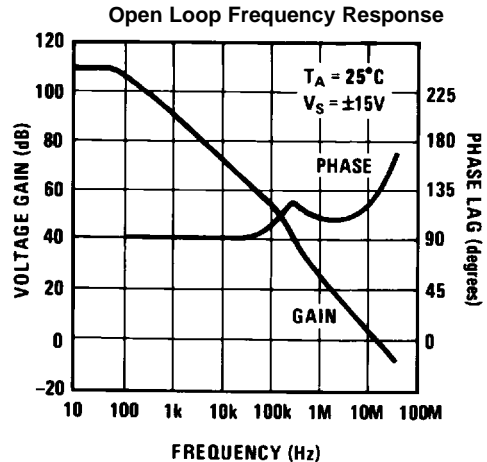


Figure 14.

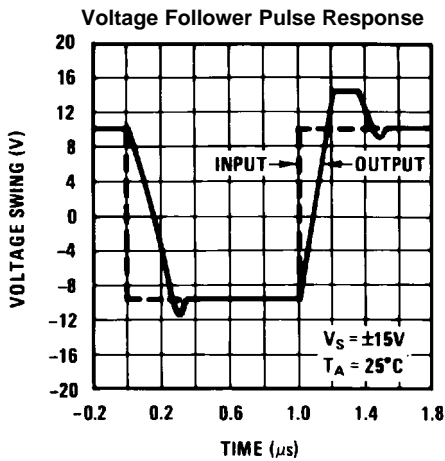


Figure 15.

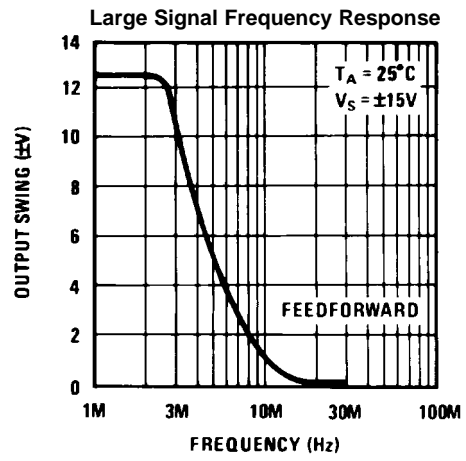


Figure 16.

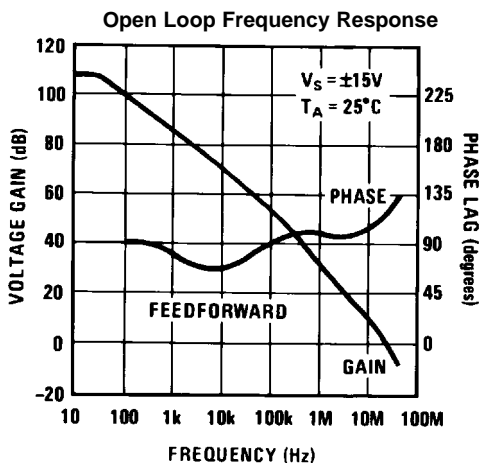


Figure 17.

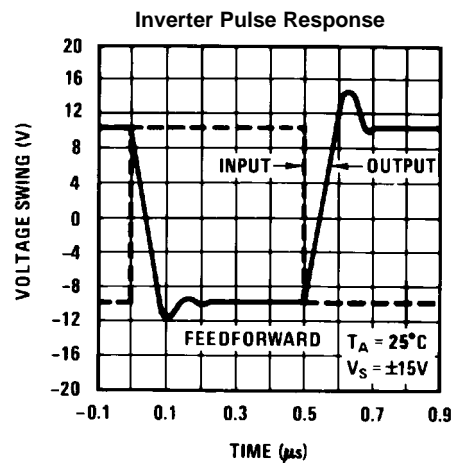


Figure 18.

Typical Performance Characteristics

LM318

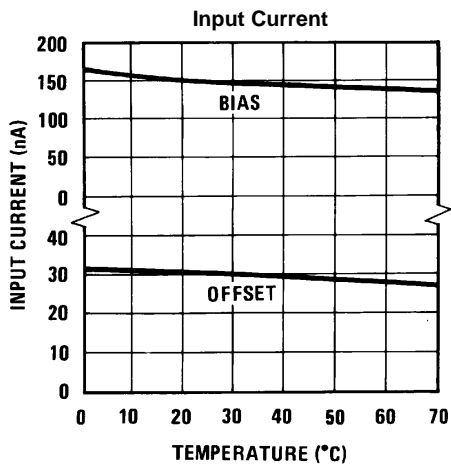


Figure 19.

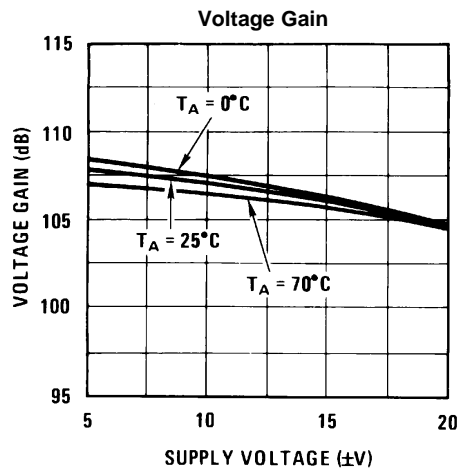


Figure 20.

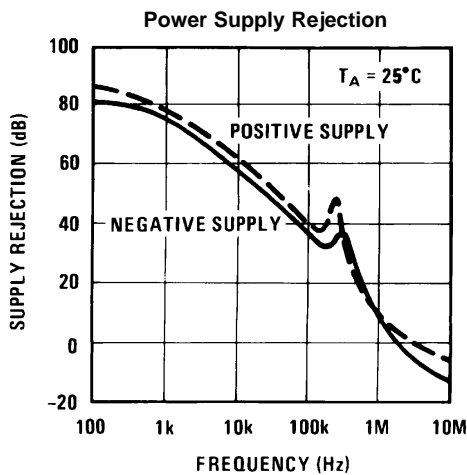


Figure 21.

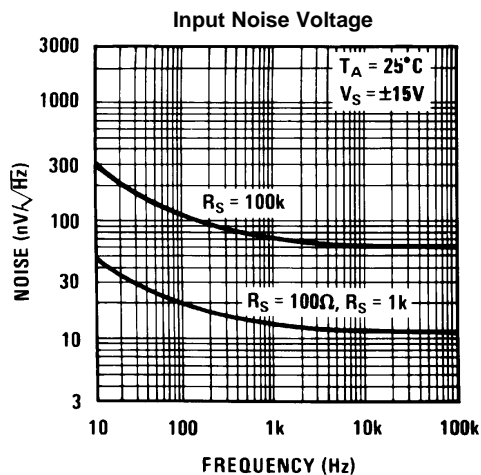


Figure 22.

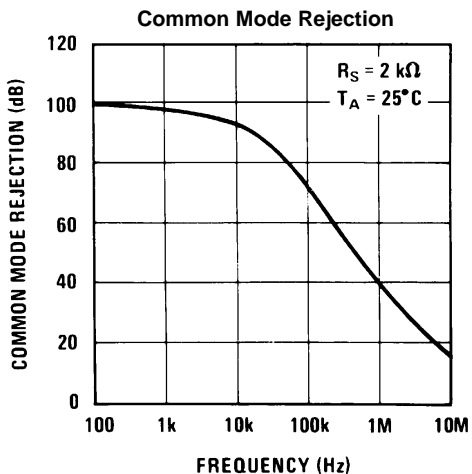


Figure 23.

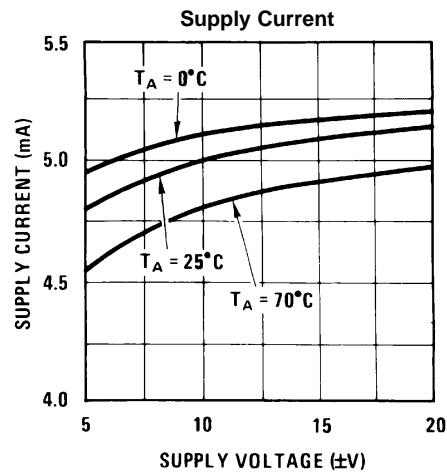


Figure 24.

Typical Performance Characteristics (continued)

LM318

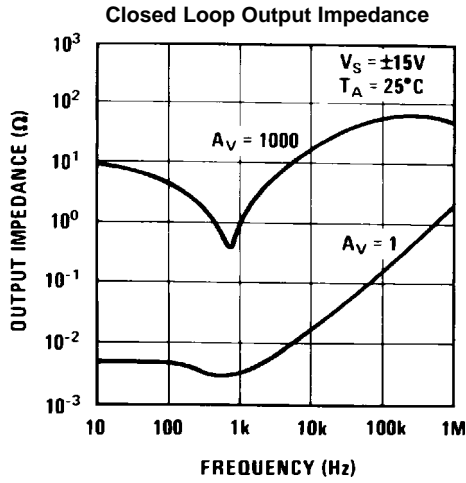


Figure 25.

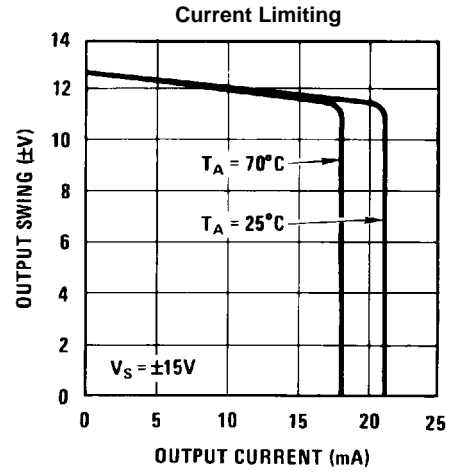


Figure 26.

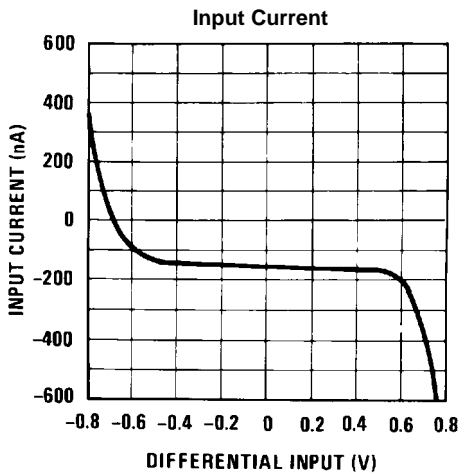


Figure 27.

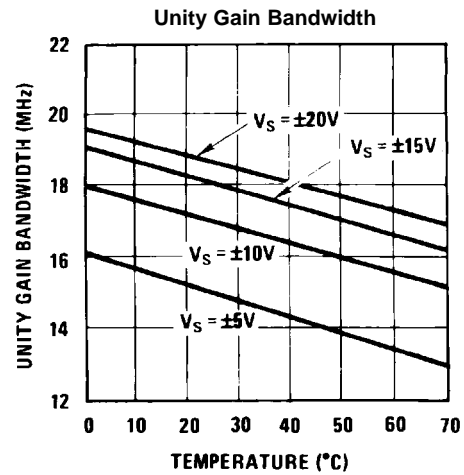


Figure 28.

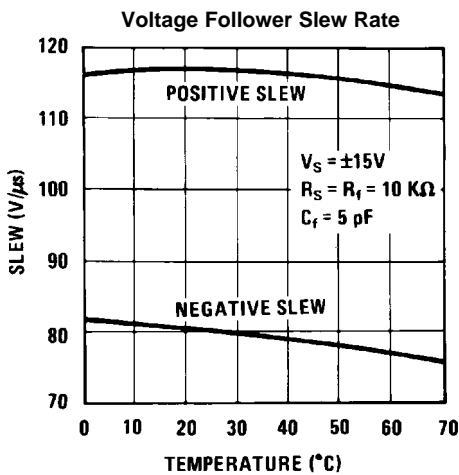


Figure 29.

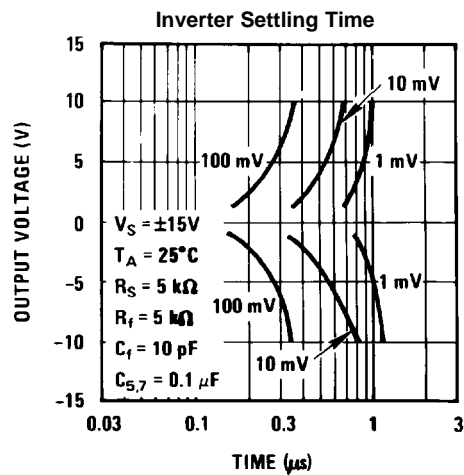


Figure 30.

Typical Performance Characteristics (continued)

LM318

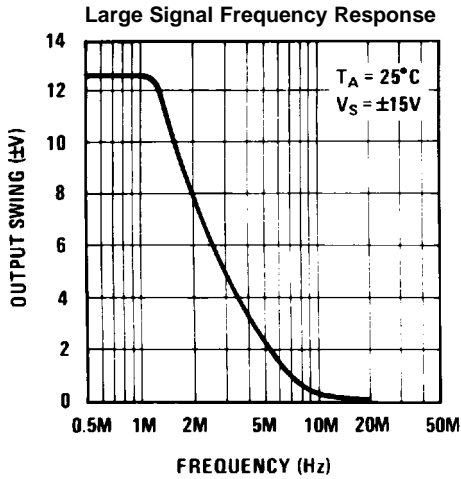


Figure 31.

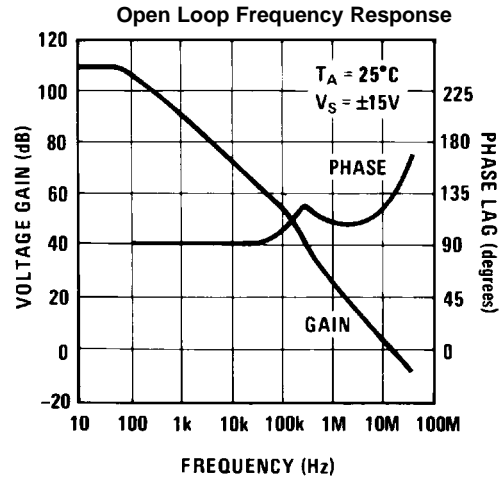


Figure 32.

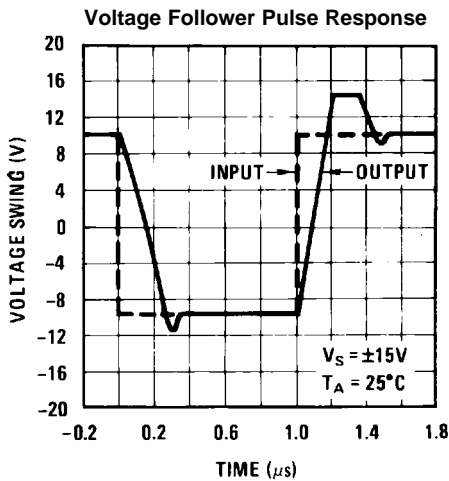


Figure 33.

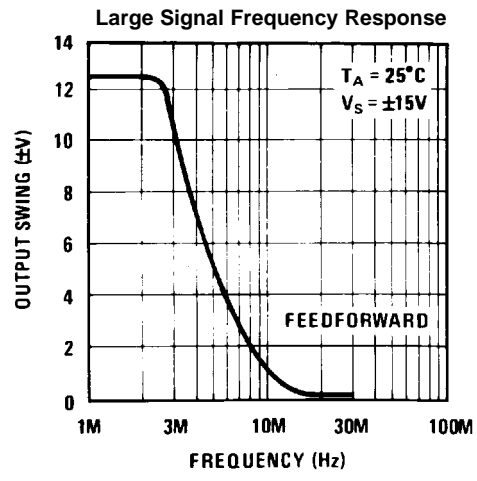


Figure 34.

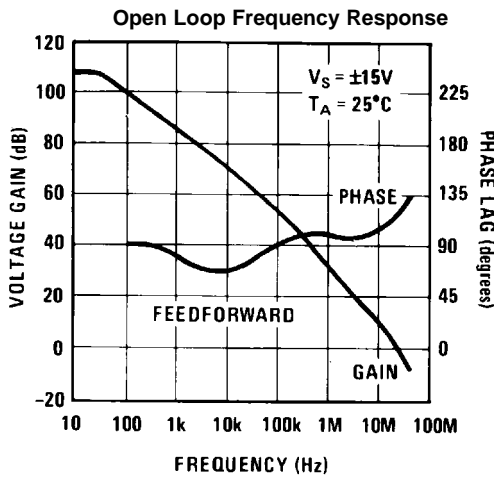


Figure 35.

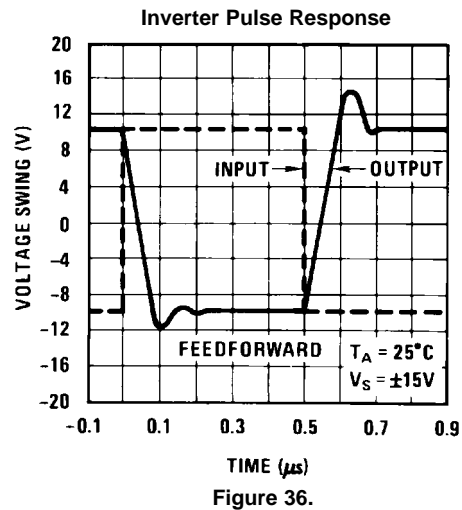
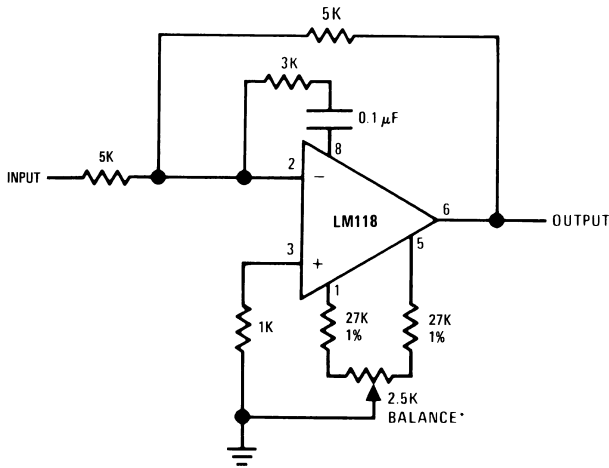


Figure 36.

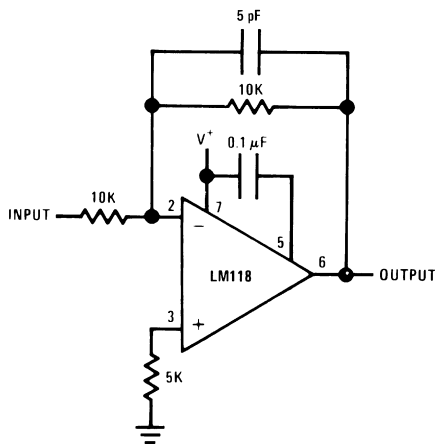
AUXILIARY CIRCUITS



\*Balance circuit necessary for increased slew.

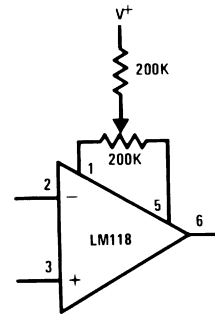
Slew rate typically 150V/μs.

**Figure 37. Feedforward Compensation for Greater Inverting Slew Rate**

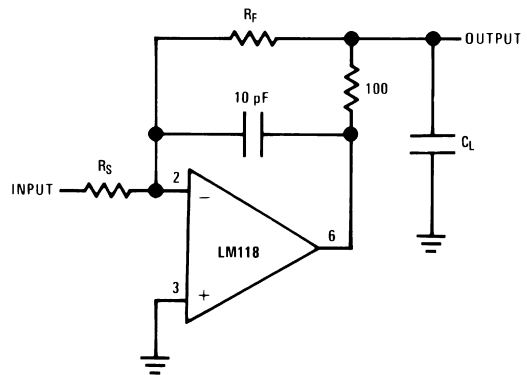


Slew and settling time to 0.1% for a 10V step change is 800 ns.

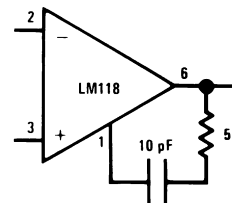
**Figure 38. Compensation for Minimum Settling Time**



**Figure 39. Offset Balancing**

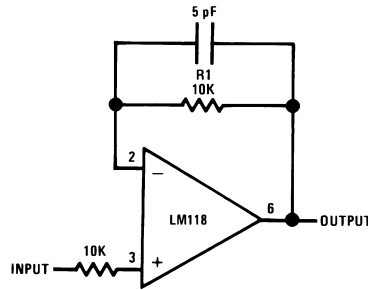


**Figure 40. Isolating Large Capacitive Loads**



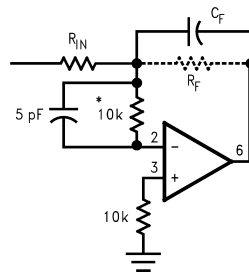
**Figure 41. Overcompensation**

TYPICAL APPLICATIONS



Do not hard-wire as voltage follower ( $R_1 \geq 5 \text{ k}\Omega$ )

Figure 42. Fast Voltage Follower



$C_F = \text{Large}$   
( $C_F \geq 50 \text{ pF}$ )

\*Do not hard-wire as integrator or slow inverter; insert a 10k-5 pF network in series with the input, to prevent oscillation.

Do not hard-wire as voltage follower ( $R_1 \geq 5 \text{ k}\Omega$ )

Figure 43.

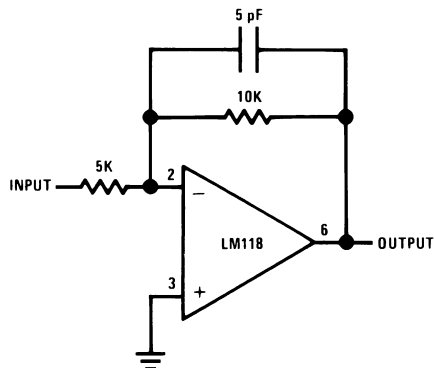


Figure 44. Fast Summing Amplifier

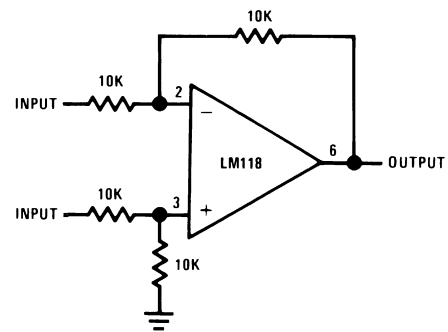


Figure 45. Differential Amplifier

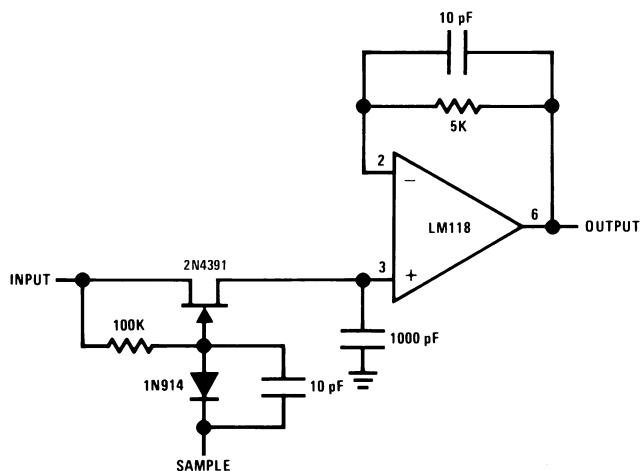
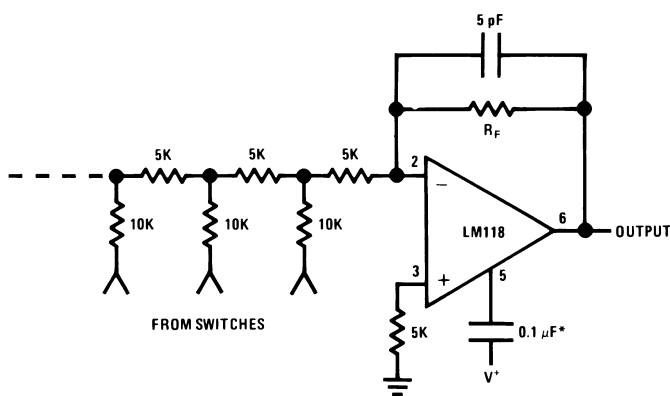


Figure 46. Fast Sample and Hold



\*Optional—Reduces settling time.

Figure 47. D/A Converter Using Ladder Network



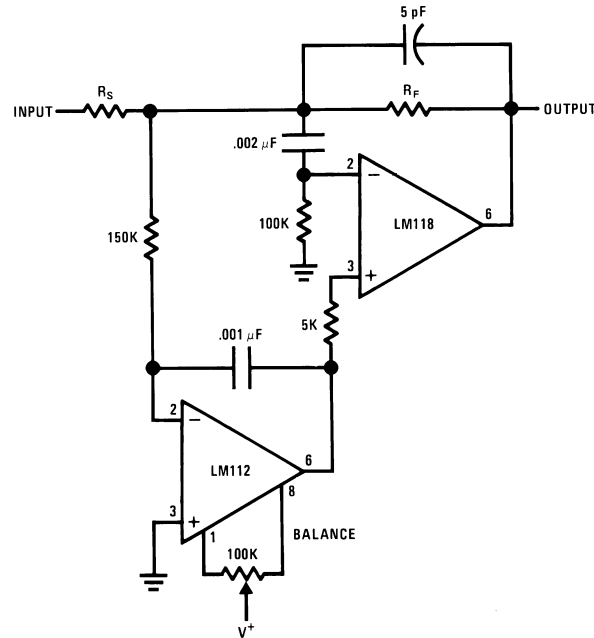
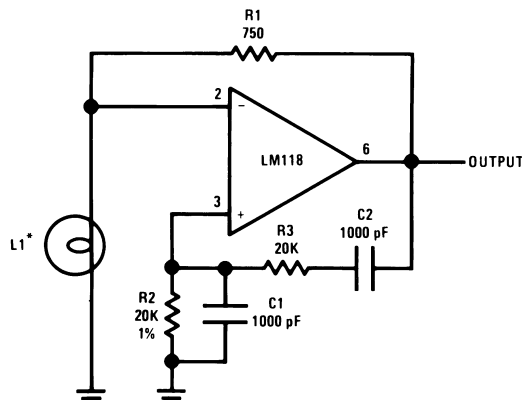


Figure 50. Fast Summing Amplifier with Low Input Current



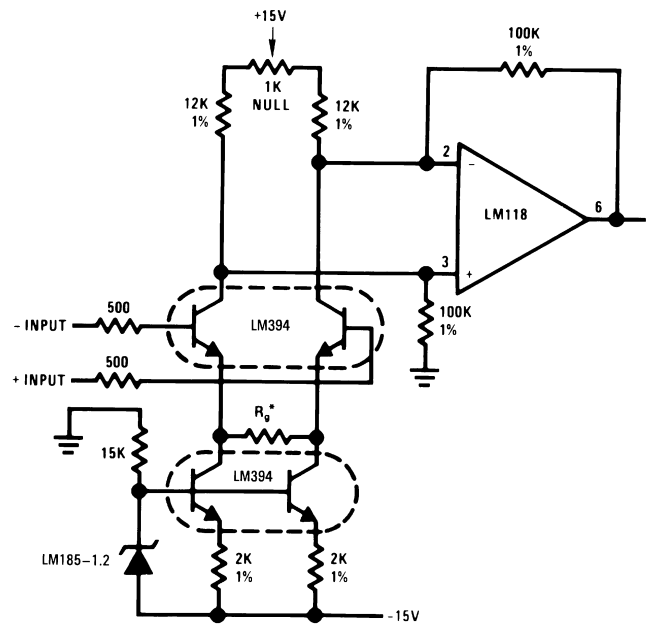
\*L1—10V—14 mA bulb ELDEMA 1869

R1 = R2

C1 = C2

$$f = \frac{1}{2\pi R_2 C_1}$$

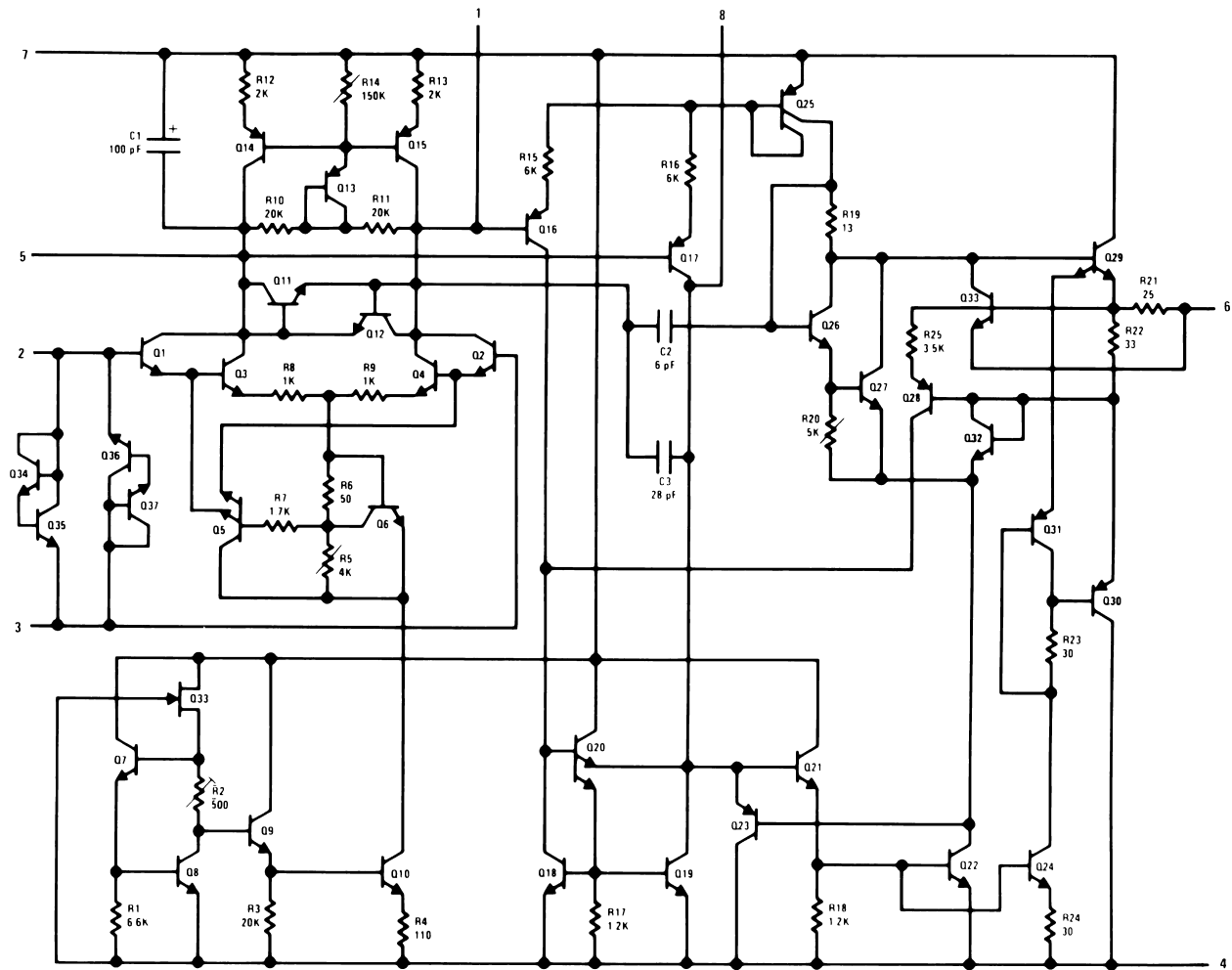
Figure 51. Wein Bridge Sine Wave Oscillator



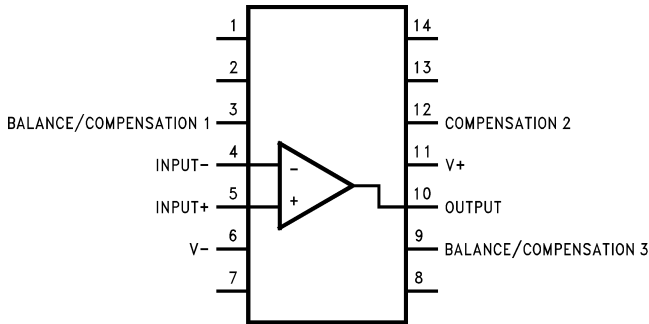
$$*Gain \geq \frac{200K}{R_g} \text{ for } 1.5K \leq R_g \leq 200K$$

Figure 52. Instrumentation Amplifier

Schematic Diagram

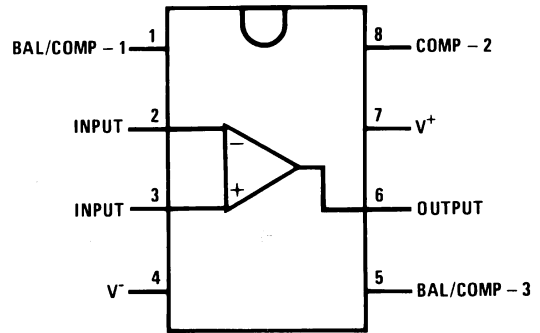


**Pin Diagram**



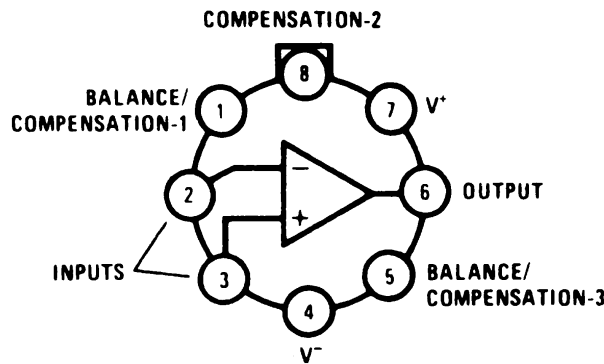
Available per JM38510/10107.

**Dual-In-Line Package  
(Top View)  
See Package Number J (R-GDIP-T14)**



Available per JM38510/10107.

**Dual-In-Line Package  
(Top View)  
See Package Number NAB008A, D (R-PDSO-G8),  
or P (R-PDIP-T8)**



Pin connections shown on schematic diagram and typical applications are for TO-99 package.

**TO-99 Package  
(Top View)  
See Package Number LMC (O-MBCY-W8)**

**PACKAGING INFORMATION**

Orderable Device	Status (1)	Package Type	Package Drawing	Pins	Package Qty	Eco Plan (2)	Lead/Ball Finish	MSL Peak Temp (3)	Op Temp (°C)	Top-Side Markings (4)	Samples
LM118H	ACTIVE	TO-99	LMC	8	500	TBD	POST-PLATE	Level-1-NA-UNLIM	-55 to 125	LM118H	<a href="#">Samples</a>
LM118H/NOPB	ACTIVE	TO-99	LMC	8	500	Green (RoHS & no Sb/Br)	POST-PLATE	Level-1-NA-UNLIM	-55 to 125	LM118H	<a href="#">Samples</a>
LM318M	ACTIVE	SOIC	D	8	95	TBD	CU SNPB	Level-1-235C-UNLIM	0 to 70	LM318M	<a href="#">Samples</a>
LM318M/NOPB	ACTIVE	SOIC	D	8	95	Green (RoHS & no Sb/Br)	CU SN	Level-1-260C-UNLIM	0 to 70	LM318M	<a href="#">Samples</a>
LM318MX	ACTIVE	SOIC	D	8	2500	TBD	CU SNPB	Level-1-235C-UNLIM	0 to 70	LM318M	<a href="#">Samples</a>
LM318MX/NOPB	ACTIVE	SOIC	D	8	2500	Green (RoHS & no Sb/Br)	CU SN	Level-1-260C-UNLIM	0 to 70	LM318M	<a href="#">Samples</a>
LM318N	ACTIVE	PDIP	P	8	40	TBD	Call TI	Level-1-NA-UNLIM	0 to 70	LM318N	<a href="#">Samples</a>
LM318N/NOPB	ACTIVE	PDIP	P	8	40	Green (RoHS & no Sb/Br)	Call TI	Level-1-NA-UNLIM	0 to 70	LM318N	<a href="#">Samples</a>

(1) The marketing status values are defined as follows:

**ACTIVE:** Product device recommended for new designs.

**LIFEBUY:** TI has announced that the device will be discontinued, and a lifetime-buy period is in effect.

**NRND:** Not recommended for new designs. Device is in production to support existing customers, but TI does not recommend using this part in a new design.

**PREVIEW:** Device has been announced but is not in production. Samples may or may not be available.

**OBSOLETE:** TI has discontinued the production of the device.

(2) Eco Plan - The planned eco-friendly classification: Pb-Free (RoHS), Pb-Free (RoHS Exempt), or Green (RoHS & no Sb/Br) - please check <http://www.ti.com/productcontent> for the latest availability information and additional product content details.

**TBD:** The Pb-Free/Green conversion plan has not been defined.

**Pb-Free (RoHS):** TI's terms "Lead-Free" or "Pb-Free" mean semiconductor products that are compatible with the current RoHS requirements for all 6 substances, including the requirement that lead not exceed 0.1% by weight in homogeneous materials. Where designed to be soldered at high temperatures, TI Pb-Free products are suitable for use in specified lead-free processes.

**Pb-Free (RoHS Exempt):** This component has a RoHS exemption for either 1) lead-based flip-chip solder bumps used between the die and package, or 2) lead-based die adhesive used between the die and leadframe. The component is otherwise considered Pb-Free (RoHS compatible) as defined above.

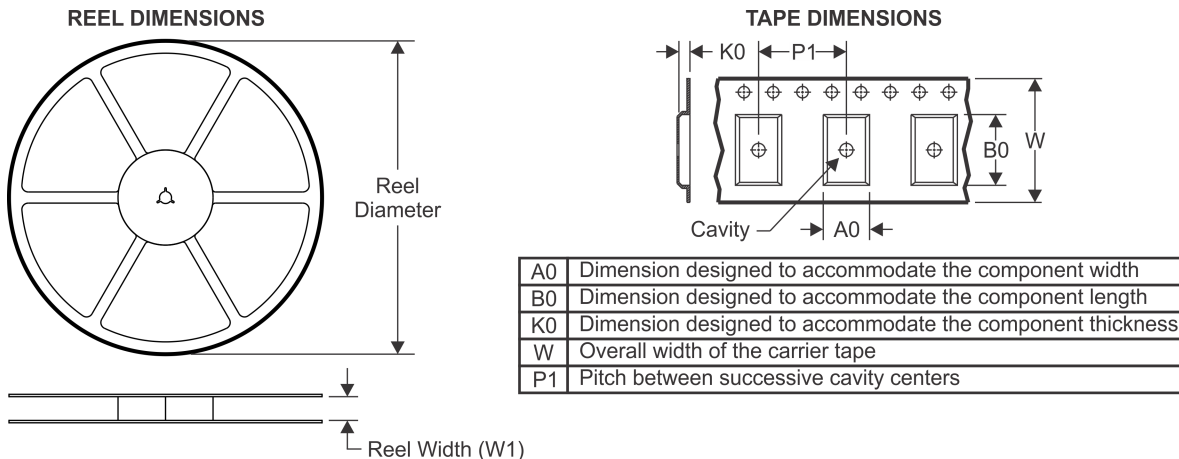
**Green (RoHS & no Sb/Br):** TI defines "Green" to mean Pb-Free (RoHS compatible), and free of Bromine (Br) and Antimony (Sb) based flame retardants (Br or Sb do not exceed 0.1% by weight in homogeneous material)

(3) MSL, Peak Temp. -- The Moisture Sensitivity Level rating according to the JEDEC industry standard classifications, and peak solder temperature.

<sup>(4)</sup> Only one of markings shown within the brackets will appear on the physical device.

**Important Information and Disclaimer:** The information provided on this page represents TI's knowledge and belief as of the date that it is provided. TI bases its knowledge and belief on information provided by third parties, and makes no representation or warranty as to the accuracy of such information. Efforts are underway to better integrate information from third parties. TI has taken and continues to take reasonable steps to provide representative and accurate information but may not have conducted destructive testing or chemical analysis on incoming materials and chemicals. TI and TI suppliers consider certain information to be proprietary, and thus CAS numbers and other limited information may not be available for release.

In no event shall TI's liability arising out of such information exceed the total purchase price of the TI part(s) at issue in this document sold by TI to Customer on an annual basis.

**TAPE AND REEL INFORMATION**

**QUADRANT ASSIGNMENTS FOR PIN 1 ORIENTATION IN TAPE**


\*All dimensions are nominal

Device	Package Type	Package Drawing	Pins	SPQ	Reel Diameter (mm)	Reel Width W1 (mm)	A0 (mm)	B0 (mm)	K0 (mm)	P1 (mm)	W (mm)	Pin1 Quadrant
LM318MX	SOIC	D	8	2500	330.0	12.4	6.5	5.4	2.0	8.0	12.0	Q1
LM318MX/NOPB	SOIC	D	8	2500	330.0	12.4	6.5	5.4	2.0	8.0	12.0	Q1

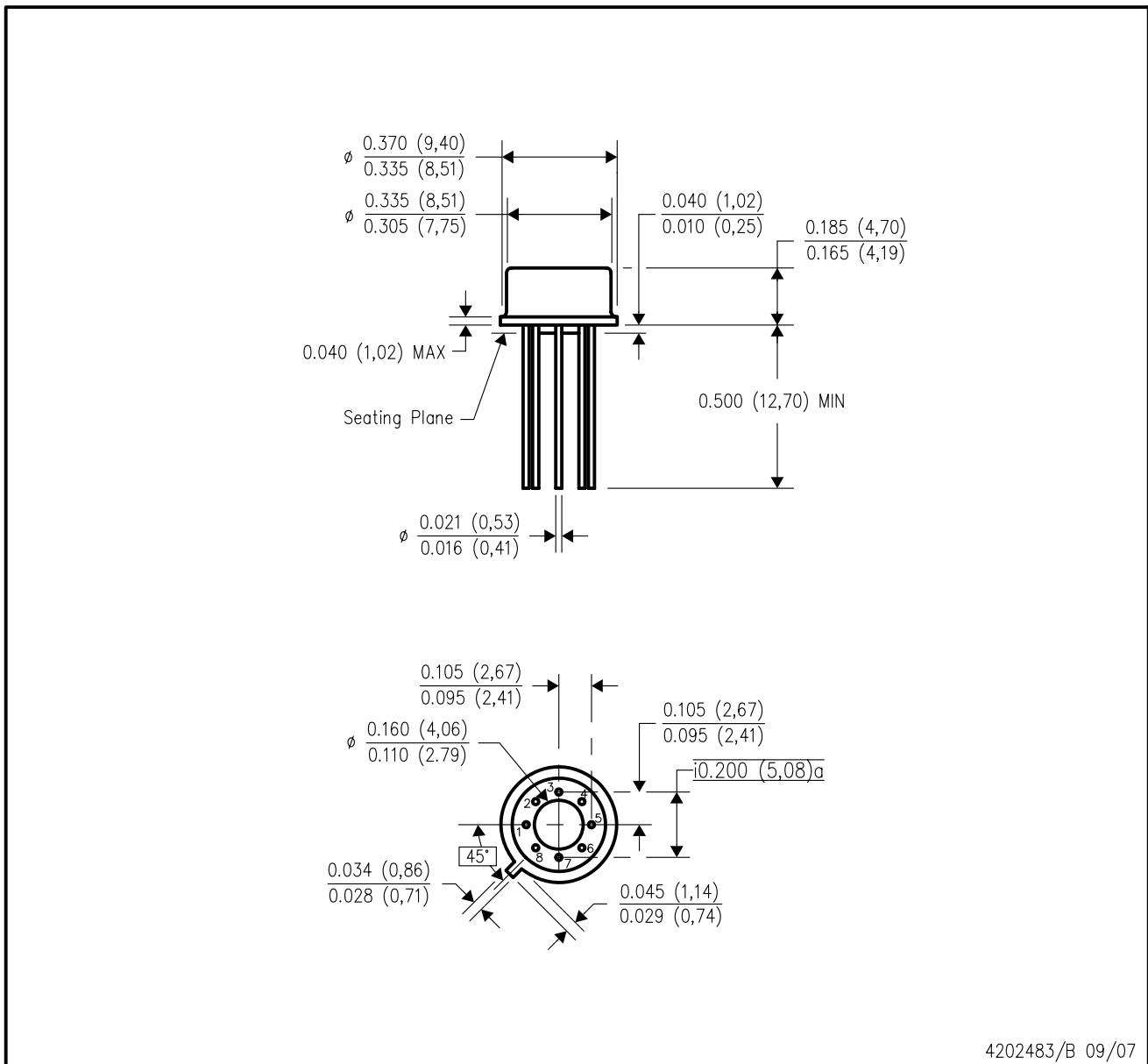
**TAPE AND REEL BOX DIMENSIONS**


\*All dimensions are nominal

Device	Package Type	Package Drawing	Pins	SPQ	Length (mm)	Width (mm)	Height (mm)
LM318MX	SOIC	D	8	2500	349.0	337.0	45.0
LM318MX/NOPB	SOIC	D	8	2500	349.0	337.0	45.0

LMC (O-MBCY-W8)

METAL CYLINDRICAL PACKAGE



- NOTES:
- A. All linear dimensions are in inches (millimeters).
  - B. This drawing is subject to change without notice.
  - C. Leads in true position within 0.010 (0,25) R @ MMC at seating plane.
  - D. Pin numbers shown for reference only. Numbers may not be marked on package.
  - E. Falls within JEDEC MO-002/TO-99.

P (R-PDIP-T8)

PLASTIC DUAL-IN-LINE PACKAGE





- NOTES:
- A. All linear dimensions are in inches (millimeters).
  - B. This drawing is subject to change without notice.
  - C. Falls within JEDEC MS-001 variation BA.

D (R-PDSO-G8)

PLASTIC SMALL OUTLINE



- NOTES:
- A. All linear dimensions are in inches (millimeters).
  - B. This drawing is subject to change without notice.
  -  Body length does not include mold flash, protrusions, or gate burrs. Mold flash, protrusions, or gate burrs shall not exceed 0.006 (0,15) each side.
  -  Body width does not include interlead flash. Interlead flash shall not exceed 0.017 (0,43) each side.
  - E. Reference JEDEC MS-012 variation AA.

## IMPORTANT NOTICE

Texas Instruments Incorporated and its subsidiaries (TI) reserve the right to make corrections, enhancements, improvements and other changes to its semiconductor products and services per JESD46, latest issue, and to discontinue any product or service per JESD48, latest issue. Buyers should obtain the latest relevant information before placing orders and should verify that such information is current and complete. All semiconductor products (also referred to herein as "components") are sold subject to TI's terms and conditions of sale supplied at the time of order acknowledgment.

TI warrants performance of its components to the specifications applicable at the time of sale, in accordance with the warranty in TI's terms and conditions of sale of semiconductor products. Testing and other quality control techniques are used to the extent TI deems necessary to support this warranty. Except where mandated by applicable law, testing of all parameters of each component is not necessarily performed.

TI assumes no liability for applications assistance or the design of Buyers' products. Buyers are responsible for their products and applications using TI components. To minimize the risks associated with Buyers' products and applications, Buyers should provide adequate design and operating safeguards.

TI does not warrant or represent that any license, either express or implied, is granted under any patent right, copyright, mask work right, or other intellectual property right relating to any combination, machine, or process in which TI components or services are used. Information published by TI regarding third-party products or services does not constitute a license to use such products or services or a warranty or endorsement thereof. Use of such information may require a license from a third party under the patents or other intellectual property of the third party, or a license from TI under the patents or other intellectual property of TI.

Reproduction of significant portions of TI information in TI data books or data sheets is permissible only if reproduction is without alteration and is accompanied by all associated warranties, conditions, limitations, and notices. TI is not responsible or liable for such altered documentation. Information of third parties may be subject to additional restrictions.

Resale of TI components or services with statements different from or beyond the parameters stated by TI for that component or service voids all express and any implied warranties for the associated TI component or service and is an unfair and deceptive business practice. TI is not responsible or liable for any such statements.

Buyer acknowledges and agrees that it is solely responsible for compliance with all legal, regulatory and safety-related requirements concerning its products, and any use of TI components in its applications, notwithstanding any applications-related information or support that may be provided by TI. Buyer represents and agrees that it has all the necessary expertise to create and implement safeguards which anticipate dangerous consequences of failures, monitor failures and their consequences, lessen the likelihood of failures that might cause harm and take appropriate remedial actions. Buyer will fully indemnify TI and its representatives against any damages arising out of the use of any TI components in safety-critical applications.

In some cases, TI components may be promoted specifically to facilitate safety-related applications. With such components, TI's goal is to help enable customers to design and create their own end-product solutions that meet applicable functional safety standards and requirements. Nonetheless, such components are subject to these terms.

No TI components are authorized for use in FDA Class III (or similar life-critical medical equipment) unless authorized officers of the parties have executed a special agreement specifically governing such use.

Only those TI components which TI has specifically designated as military grade or "enhanced plastic" are designed and intended for use in military/aerospace applications or environments. Buyer acknowledges and agrees that any military or aerospace use of TI components which have **not** been so designated is solely at the Buyer's risk, and that Buyer is solely responsible for compliance with all legal and regulatory requirements in connection with such use.

TI has specifically designated certain components as meeting ISO/TS16949 requirements, mainly for automotive use. In any case of use of non-designated products, TI will not be responsible for any failure to meet ISO/TS16949.

### Products

Audio	<a href="http://www.ti.com/audio">www.ti.com/audio</a>
Amplifiers	<a href="http://amplifier.ti.com">amplifier.ti.com</a>
Data Converters	<a href="http://dataconverter.ti.com">dataconverter.ti.com</a>
DLP® Products	<a href="http://www.dlp.com">www.dlp.com</a>
DSP	<a href="http://dsp.ti.com">dsp.ti.com</a>
Clocks and Timers	<a href="http://www.ti.com/clocks">www.ti.com/clocks</a>
Interface	<a href="http://interface.ti.com">interface.ti.com</a>
Logic	<a href="http://logic.ti.com">logic.ti.com</a>
Power Mgmt	<a href="http://power.ti.com">power.ti.com</a>
Microcontrollers	<a href="http://microcontroller.ti.com">microcontroller.ti.com</a>
RFID	<a href="http://www.ti-rfid.com">www.ti-rfid.com</a>
OMAP Applications Processors	<a href="http://www.ti.com/omap">www.ti.com/omap</a>
Wireless Connectivity	<a href="http://www.ti.com/wirelessconnectivity">www.ti.com/wirelessconnectivity</a>

### Applications

Automotive and Transportation	<a href="http://www.ti.com/automotive">www.ti.com/automotive</a>
Communications and Telecom	<a href="http://www.ti.com/communications">www.ti.com/communications</a>
Computers and Peripherals	<a href="http://www.ti.com/computers">www.ti.com/computers</a>
Consumer Electronics	<a href="http://www.ti.com/consumer-apps">www.ti.com/consumer-apps</a>
Energy and Lighting	<a href="http://www.ti.com/energy">www.ti.com/energy</a>
Industrial	<a href="http://www.ti.com/industrial">www.ti.com/industrial</a>
Medical	<a href="http://www.ti.com/medical">www.ti.com/medical</a>
Security	<a href="http://www.ti.com/security">www.ti.com/security</a>
Space, Avionics and Defense	<a href="http://www.ti.com/space-avionics-defense">www.ti.com/space-avionics-defense</a>
Video and Imaging	<a href="http://www.ti.com/video">www.ti.com/video</a>

### TI E2E Community

[e2e.ti.com](http://e2e.ti.com)