

# LH4101/LH4101C Wideband High Current Operational Amplifier

## General Description

The LH4101 is a high slew rate, FET input, wideband operational amplifier designed for applications that require an op amp to provide up to 200 mA peak and 100 mA continuous output current. This feature eliminates the need for a buffer to provide the additional current drive not available with most wideband op amps.

Designed for use with minimum external circuitry, the LH4101 provides internal compensation for unity gain stability and all the gain set resistors for most popular gain settings, as well as internal supply bypass capacitors. These features minimize the circuit's sensitivity to external layout conditions. These features are provided in a 24 pin hermetic dual in-line package.

## Features

- 45 MHz bandwidth
- $10^{12}\Omega$  input impedance
- Pin strappable gain settings of 1, 2, 3, 4, -1, -2, -3
- Unity gain stable
- Internal supply bypassing
- 100 mA continuous output current
- 24 pin hermetic DIP
- Directly drives  $50\Omega$  loads

The LH4101's wide bandwidth, programmable gain settings, and high output current make it an ideal choice for fast buffering applications such as video distribution. It is also appropriate for use in summing amplifiers, sample and hold circuits, and high speed integrators.

## Block and Connection Diagrams

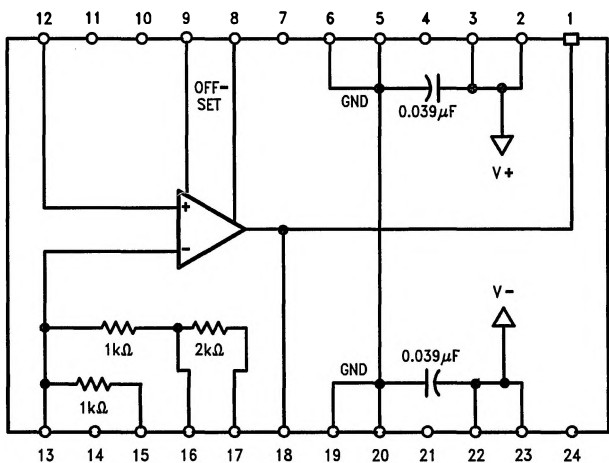

TL/K/8549-1

### Dual In-Line Package

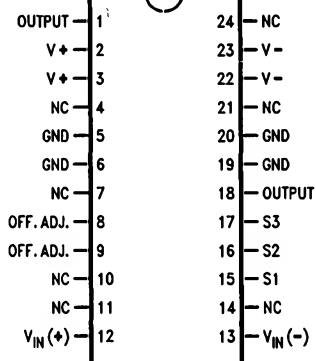

TL/K/8543-2

**Order Number LH4101D or  
LH4101CD**  
See NS Package Number D24D

## Absolute Maximum Ratings

If Military/Aerospace specified devices are required, please contact the National Semiconductor Sales Office/Distributors for availability and specifications.

Supply Voltage, $V_S$	$\pm 17V$
Power Dissipation, at $T_A = 25^\circ C$ , $P_D$	2W
Input Voltage Range, $V_{CM}$	$\pm V_S$
Steady State Output Current, $I_O$	$\pm 100 mA$

Operating Temperature Range, $T_A$	LH4101CD	$-25^\circ C$ to $+85^\circ C$
	LH4101D	$-55^\circ C$ to $+125^\circ C$
Storage Temperature Range, $T_{STG}$		$-65^\circ C$ to $+150^\circ C$
Maximum Junction Temperature, $T_J$		$175^\circ C$
Lead Temperature (Soldering $< 10$ sec.)		$300^\circ C$
ESD rating to be determined		

## DC Electrical Characteristics $V_S = \pm 15V$ , $T_{MIN} \leq T_A \leq T_{MAX}$ unless otherwise specified

Symbol	Parameter	Test Conditions	Min	Typ	Max	Units
$V_{OS}$	Input Offset Voltage	$V_{IN} = 0V$	$T_A = T_J = 25^\circ C$ (Note 1)		15	mV
					25	mV
$\frac{\Delta V_{OS}}{\Delta T}$	Average Offset Voltage Drift			25		$\mu V/^\circ C$
$I_B$	Input Bias Current				500	pA
					500	nA
$I_{OS}$	Input Offset Current		$T_A = T_J = 25^\circ C$ (Note 1)		200	pA
					200	nA
					200	nA
CMRR	Common Mode Rejection Ratio	$\Delta V_{IN} = \pm 10V$	50	60		dB
PSRR	Power Supply Rejection Ratio	$\Delta V_S = \pm 10V$	50	60		dB
$A_{VOL}$	Open-Loop Voltage Gain	$V_O = \pm 10V$ , $R_L = 1 k\Omega$ , $f = 1 kHz$ $V_O = \pm 5V$ , $R_L = 50\Omega$ , $f = 1 kHz$ , $T_A = 25^\circ C$	60	65		dB
			57	62		dB
$V_O$	Output Voltage Swing	$V_{IN} = \pm 15V$ , $R_L = 1 k\Omega$ $V_{IN} = \pm 5.5V$ , $R_L = 50\Omega$ , $T_J = 25^\circ C$ (Note 2)	$\pm 10$ $\pm 5$	$\pm 13.5$		V V
$I_S$	Supply Current	$R_L = 1 k\Omega$		25	40	mA
$e_{-3}$	Gain Error $A_V = -3$	$V_{IN} = \pm 1V$ , $R_L = 50\Omega$ , $T_J = 25^\circ C$		0.8	2	%
$e_{-1}$	Gain Error $A_V = -1$			0.8	2	%

**Note 1:** Specification is at  $25^\circ C$  junction temperature due to requirements of high speed automatic testing. Actual values at operating temperature will exceed the value at  $T_J = 25^\circ C$ .

**Note 2:** The output swing is limited by the maximum output current of  $\pm 100 mA$  when  $R_L = 50\Omega$ . When the LH4101 is operated at elevated temperature (such as  $125^\circ C$ ), some form of heatsinking or forced air cooling is required. The quiescent power with  $V_S$  of  $\pm 15V$  is 1.2W max, whereas the package can only handle 750 mW without a heatsink at  $125^\circ C$ .

## AC Electrical Characteristics $A_V = +1$ , $R_L = 50\Omega$ , $T_A = 25^\circ C$ unless otherwise specified

Symbol	Parameter	Conditions	Min	Typ	Max	Units
$S_R$	Slew Rate	$V_{IN} = \pm 5V$	200	250		V/ $\mu s$
$f_{-3 dB}$	Small Signal Bandwidth	$V_{IN} = 100 mV_{rms}$		45		MHz
$t_S$	Settling Time to 1% Settling Time to 0.1%	$\Delta V_{IN} = 10V$		140		ns
				300		ns
$t_r$	Small Signal Rise Time	$V_{IN} = 0V$ to $+100 mV$		10		ns

# Applications Information

## Power Supply Bypassing

The LH4101 will perform well in most circuit boards even without external supply bypassing; however, it is recommended that some bulk bypassing be provided. One 10  $\mu$ F electrolytic on each supply is recommended. Proximity to the device pins is not critical, but the bypass will be most effective if located within an inch of the part.

## Input Capacitance

The input capacitance to the LH4101 is typically 5 pF and for source impedances greater than 100 $\Omega$ , the input time constant should be considered.

## Gain Settings

The LH4101 provides internal gain set resistors for most popular gain settings. A chart is provided to assist in determining the proper pins to connect to achieve these gains. The internal gain resistors are trimmed and matched to insure the gain accuracy to 0.8% typically. The LH4101 can operate at other gain settings, but the user must supply additional gain set resistors external to the part.

**Frequency Response  
( $A_v = +1$  Closed Loop)**

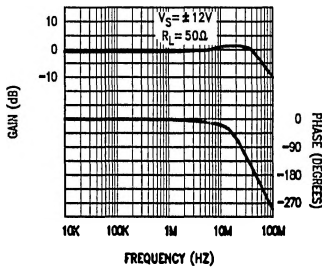

TL/K/8543-3

**Frequency Response  
(Open Loop)**

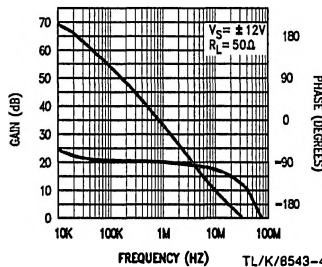

TL/K/8543-4

**Offset Null**

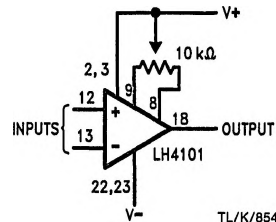

TL/K/8543-7

Gain	Connect	Pin Number	Comment
+1	$V_{out}$ to S1 $V_{out}$ to S2	18 to 15 18 to 16	For all positive gains, the input is $V_{in(+)}$ , pin 12.
+2	$V_{out}$ to S2 and S1 to GND	18 to 16 15 to 19	
+3	$V_{out}$ to S3 and S2 to $V_{in(-)}$ and S1 to GND	18 to 17 16 to 13 15 to 19	
+4	$V_{out}$ to S3 and S1 to GND	18 to 17 15 to 19	
-1	S2 to $V_{out}$	16 to 18	For all negative gains, input is S1, pin 15. Also, $V_{in(+)}$ , pin 12, MUST BE CONNECTED TO GROUND.
-2	$V_{in(-)}$ to S2 and S3 to $V_{out}$	13 to 16 17 to 18	
-3	S3 to $V_{out}$	17 to 18	

## Typical Applications

### Unity Gain Follower

The LH4101 can be used as a unity gain follower to provide output current to drive 50Ω or 75Ω coax cable directly. By shorting pins 15, 16 and 18, a follower circuit is configured as seen in *Figure 1a*. This configuration features a band-

width greater than 40 MHz with an input signal of 1.0 V<sub>p-p</sub> and greater than 16 MHz with a 5 V<sub>p-p</sub> input signal. This is all achieved without any external components. *Figures 1b* and *1c* show the small and large signal pulse responses, respectively.

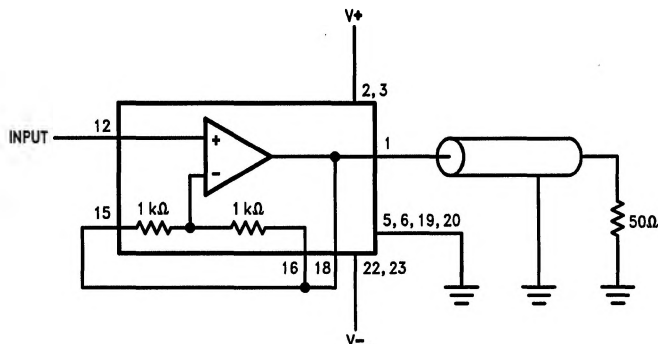
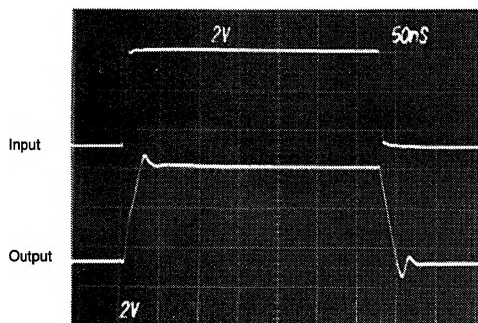

FIGURE 1a. Unity Gain Follower

TL/K/8543-5

### Large Signal Pulse Response



V<sub>S</sub> = ±15V  
A<sub>V</sub> = 1  
R<sub>L</sub> = 50Ω

TL/K/8543-9

FIGURE 1b

### Small Signal Pulse Response

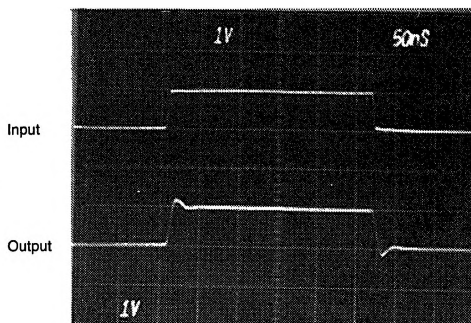

V<sub>S</sub> = ±15V  
A<sub>V</sub> = 1  
R<sub>L</sub> = 50Ω

TL/K/8543-10

FIGURE 1c

### Maximum Power Dissipation

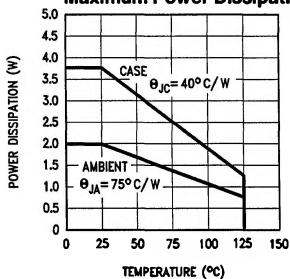

TL/K/8543-13

**Non-Inverting Amplifier**

To configure the LH4101 as a non-inverting amplifier with a gain of 4, short pins 17 to 18 and 15 to 19, as shown in *Figure 2a*. Again, no external components are necessary. This configuration provides a bandwidth of 25 MHz with an

input sine wave of 1.0 V<sub>p-p</sub> and a bandwidth of 10 MHz with an input of 5 V<sub>p-p</sub> while providing 100 mA of output current. This eliminates the need of an additional buffer in the circuit to provide the output current to drive large loads. *Figures 2b* and *2c* show the small and large signal pulse responses, respectively.

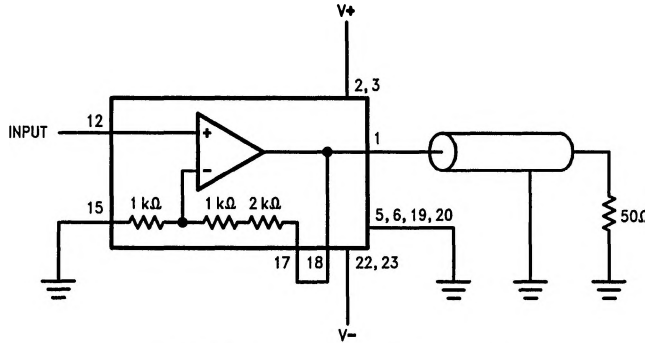

**FIGURE 2a. Non-Inverter with Gain of +4**

TL/K/8543-8

**Large Signal Pulse Response**

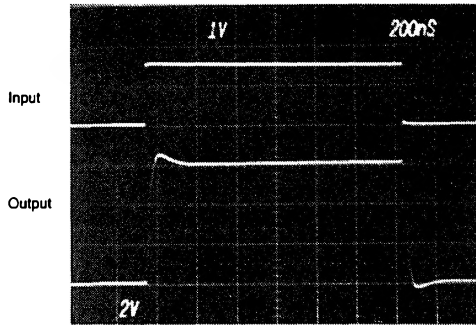

V<sub>S</sub> = ±15V  
A<sub>V</sub> = 4  
R<sub>L</sub> = 50Ω

TL/K/8543-11

**FIGURE 2b**

**Small Signal Pulse Response**

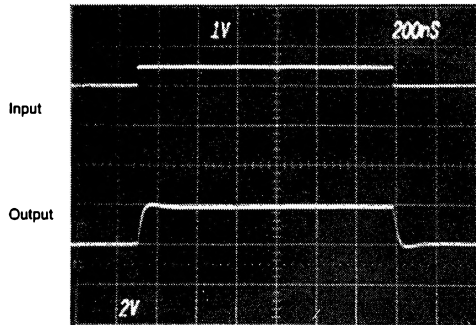

V<sub>S</sub> = ±15V  
A<sub>V</sub> = 4  
R<sub>L</sub> = 50Ω

TL/K/8543-12

**FIGURE 2c**

**Differential Amplifier**

To configure the LH4101 as a differential amplifier, two additional 1 kΩ resistors are required. *Figure 3* shows this con-

figuration, where V<sub>O</sub> = V<sub>1</sub> - V<sub>2</sub>. The gain accuracy of this circuit is dependent upon the gain accuracy of the additional 1 kΩ resistors.

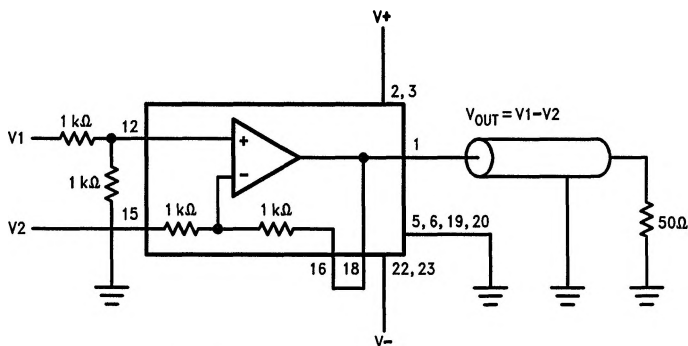

**FIGURE 3. Wideband Differential Amplifier**

TL/K/8543-6