



LH0045/LH0045C Two Wire Transmitter

General Description

The LH0045/LH0045C Two Wire Transmitters are linear integrated circuits designed to convert the voltage from a sensor to a current, and send it through to a receiver, utilizing the same simple twisted pair as the supply voltage.

The LH0045 and LH0045C contain an internal reference designed to power the sensor bridge, a sensitive input amplifier, and an output current source. The output current scale can be adjusted to match the industry standards of 4.0 mA to 20 mA or 10 mA to 50 mA.

Designed for use with various sensors, the LH0045/LH0045C will interface with thermocouples, strain gauges, or thermistors. The use of the power supply leads as the signal output eliminates two or three extra wires in remote signal applications. Also, current output minimizes susceptibility to voltage noise spikes and eliminates line drop problems.

The LH0045/LH0045C is intended to fulfill a wide variety of process control, instrumentation, and data acquisition applications. The LH0045 is guaranteed over the temperature range of -55°C to $+125^{\circ}\text{C}$; whereas the LH0045C is guaranteed from -25°C to $+85^{\circ}\text{C}$.

Features

- High sensitivity $> 10 \mu\text{A}/\mu\text{V}$
- Low input offset voltage 1.0 mV
- Low input bias current 2.0 nA
- Single supply operation 10V to 50V
- Programmable bridge reference (LH0045G) 5.0V to 30V
- Non-interactive span and null adjust
- Over compensation capability
- Supply reversal protection

Equivalent Schematic

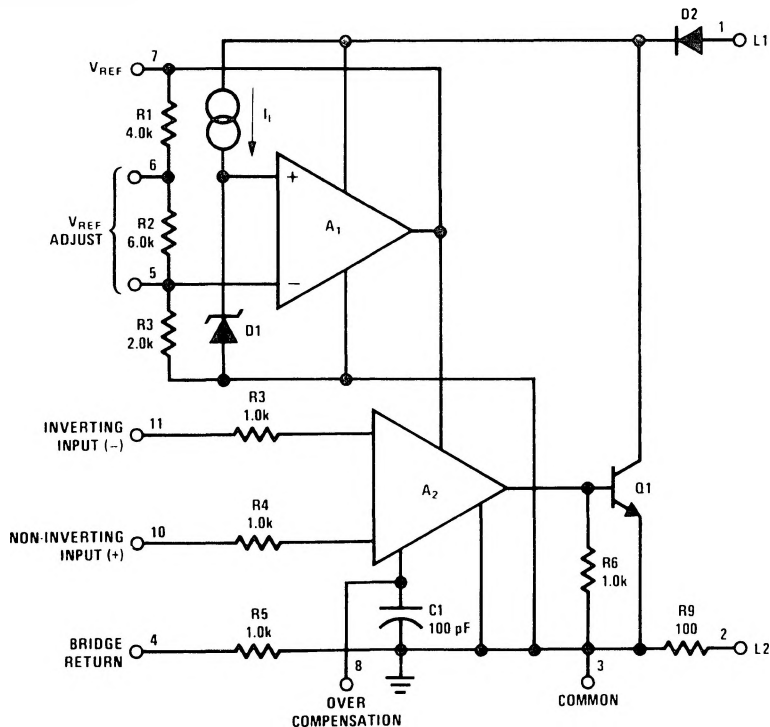

*Note: Pins shown are for the 12 pin to 8 ("G") package.

TL/K/5556-1

Absolute Maximum Ratings

If Military/Aerospace specified devices are required, contact the National Semiconductor Sales Office/Distributors for availability and specifications.

(Note 2)

Supply Voltage (L1 to common)	+ 50V
Input Current	+ 20 mA
Input Voltage (Either Input to Common)	0V to V_{REF}
Differential Input Voltage	$\pm 20V$
Output Current (Either L1 or L2)	50 mA
Reference Output Current	5.0 mA

Power Dissipation

LH0045G

1.5W

Operating Temperature Range

LH0045

-55°C to +125°C

LH0045C

-25°C to +85°C

Storage Temperature Range

-65°C to +150°C

Lead Temperature (Soldering, 10 sec.)

+ 260°C

ESD rating to be determined.

Electrical Characteristics (Note 1)

Parameter	Conditions	Limits						Units
		LH0045			LH0045C			
		Min	Typ	Max	Min	Typ	Max	
Input Offset Voltage (V_{OS})	$I_S = 4.0 \text{ mA}$, $T_A = 25^\circ\text{C}$ $I_S = 4.0 \text{ mA}$		0.7	2.0 3.0		2.0	7.5 10	mV mV
Offset Voltage Temperature Coefficient ($\Delta V_{OS}/\Delta T$)	$I_S = 4.0 \text{ mA}$		3.0			6.0		$\mu\text{V}/^\circ\text{C}$
Input Bias Current (I_B)	$T_A = 25^\circ\text{C}$		0.8	2.0 3.0		1.5	7.0 10	nA nA
Input Offset Current (I_{OS})	$T_A = 25^\circ\text{C}$		0.05	0.2 0.4		0.2	1.0 1.5	nA nA
Open Loop Transconductance (g_{MOL})	$\Delta I_S = 4.0 \text{ mA to } 20 \text{ mA}$ $\Delta I_S = 10 \text{ mA to } 50 \text{ mA}$	10^6 2×10^6	10^7 2×10^7		10^6 2×10^6	10^7 2×10^7		$\mu\Omega$ $\mu\Omega$
Supply Voltage Range (V_S)	LH0045G Pins 5 and 6 Open	9.0 15		50 50	9.0 15		50 50	V V
Input Voltage Range (V_{IN})	LH0045G Pins 5 and 6 Open	1.0 1.0		3.3 7.6	1.0 1.0		3.3 7.6	V V
Open Loop Output Impedance (R_{OUT})	$V_S = 10V \text{ to } 45V$, $I_S = 4.0 \text{ mA}$, $T_A = 25^\circ\text{C}$		1.0			1.0		$M\Omega$
Common Mode Rejection Ratio (CMRR)	$\Delta V_{IN} = 1.0V \text{ to } 3.3V$, $I_S = 12 \text{ mA}$	0.1	0.05		0.1	0.05		mV/V
Power Supply Rejection Ratio (PSRR)	$\Delta V_S = 10V \text{ to } 45V$, $I_S = 12 \text{ mA}$	0.1	0.01		0.1	0.01		mV/V
Open Loop Supply Current (I_{SOL})	$V_S = 50V$		2.0	3.0		2.0	3.0	mA
Reference Voltage Load Regulation ($\Delta V_{REF}/\Delta I_{REF}$)	$\Delta I_{REF} = 0 \text{ mA to } 2.0 \text{ mA}$, $T_A = 25^\circ\text{C}$,		0.05	0.2		0.05	0.2	%
Reference Voltage Line Regulation ($\Delta V_{REF}/\Delta V_S$)	$\Delta V_S = 10V \text{ to } 45V$, $T_A = 25^\circ\text{C}$		0.3	0.5		0.3	0.7	mV/V
Reference Voltage Temperature Coefficient ($\Delta V_{REF}/\Delta T$)	$I_{REF} = 2.0 \text{ mA}$		0.004			0.004		$\%/^\circ\text{C}$
Reference Voltage (V_{REF})	$I_{REF} = 2.0 \text{ mA}$, $T_A = 25^\circ\text{C}$ $I_{REF} = 2.0 \text{ mA}$, $T_A = 25^\circ\text{C}$, LH0045G Pins 5 and 6 Open	4.3 8.6	5.1 10.3	5.9 12	4.3 8.6	5.1 10.3	5.9 12	V V

Electrical Characteristics (Note 1) (Continued)

Parameter	Conditions	Limits						Units
		LH0045			LH0045C			
		Min	Typ	Max	Min	Typ	Max	
Resistor R9	$I_S = 12 \text{ mA}$, $T_A = 25^\circ\text{C}$	95	100	105	95	100	105	Ω
Average Temperature Coefficient of R9 (TCR ₉)	$I_S = 12 \text{ mA}$		50	300		50	300	PPM/ $^\circ\text{C}$
Resistor R5	$I_S = 1.0 \text{ mA}$, $T_A = 25^\circ\text{C}$	950	1000	1050	950	1000	1050	Ω
Average Temperature Coefficient of R5 (TCR ₅)	$I_S = 1.0 \text{ mA}$		50	300		50	300	PPM/ $^\circ\text{C}$
Input Resistance (R _{IN})	$T_A = 25^\circ\text{C}$		50			50		M Ω

Note 1: Unless otherwise specified, these specifications apply for $+10\text{V} \leq V_S \leq +50\text{V}$, pin 5 shorted to pin 6 on the LH0045G, over the temperature range -55°C to $+125^\circ\text{C}$ for the LH0045 and -25°C to $+85^\circ\text{C}$ for the LH0045C.

Note 2: Refer to RETS 0045G for LH0045G military specifications.

Connection Diagram

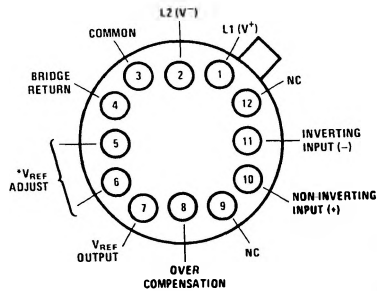

TL/K/5556-2

Top View

***Note:** Pin 5 is shorted to Pin 6 to obtain a Nominal $+5.1\text{V}$, V_{REF} . Left open $V_{\text{REF}} = +10\text{V}$.

The case is isolated from the circuit for both to 3 and to 8.

Order Number LH0045G or LH0045CG
See NS Package Number G12B

Typical Performance Characteristics

LH0045G Maximum Power Dissipation

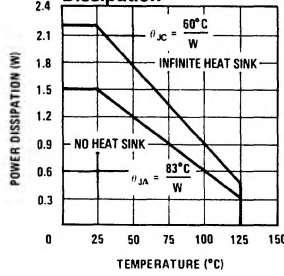

Safe Operating Area

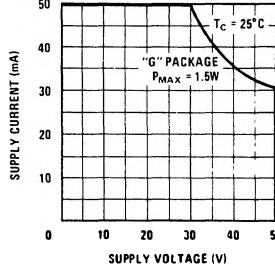

Input Noise Voltage

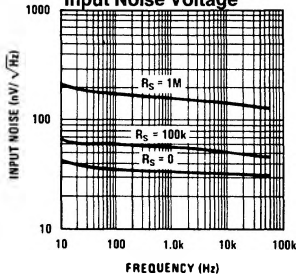

Input Currents

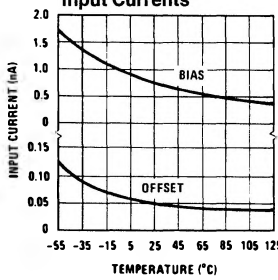

Open Loop Transconductance vs Frequency

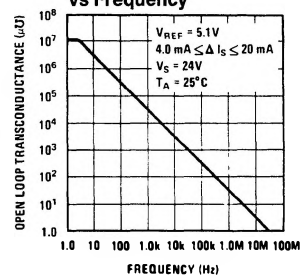

Power Supply Rejection Ratio vs Frequency

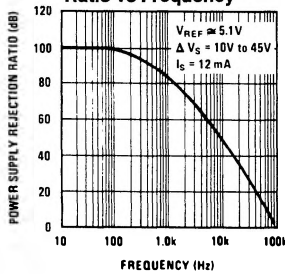

V_REF Line Regulation

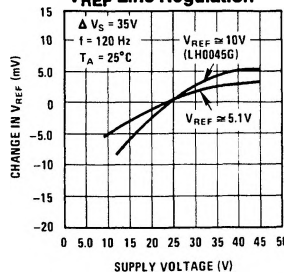

Variation of V_REF with Temperature Normalized to 25°C

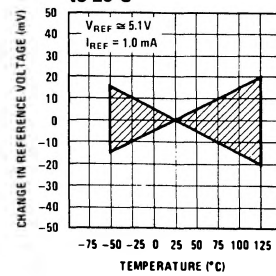

V_REF vs Resistance Between Pin 5 and Pin 3

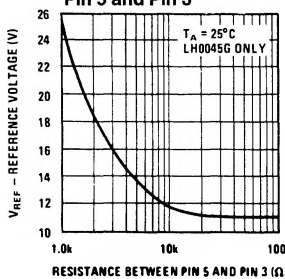

Open Loop Supply Current vs Temperature

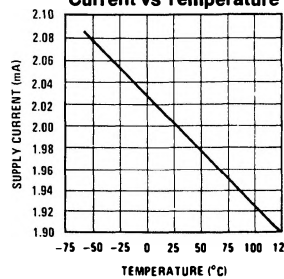

Change in R9 with Temperature Normalized to 25°C

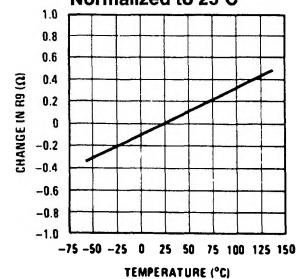

Typical Applications

Thermocouple Input Transmitter

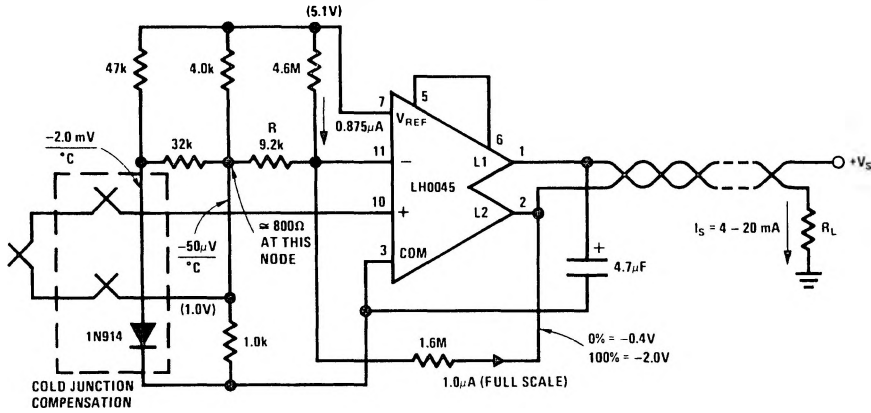

For 1 μ A Full Scale, $R_{IN} = V_{IN}/1 \mu A =$ Source Impedance @ Pin 11
 e.g., V_{IN} (Full Scale) = 10 mV, $R_{IN} = 10k$
 Bridge Impedance = 0.8k, $R = 10k - 0.8k = 9.2k$

TL/K/5556-4

Resistance Bridge Input Transmitter

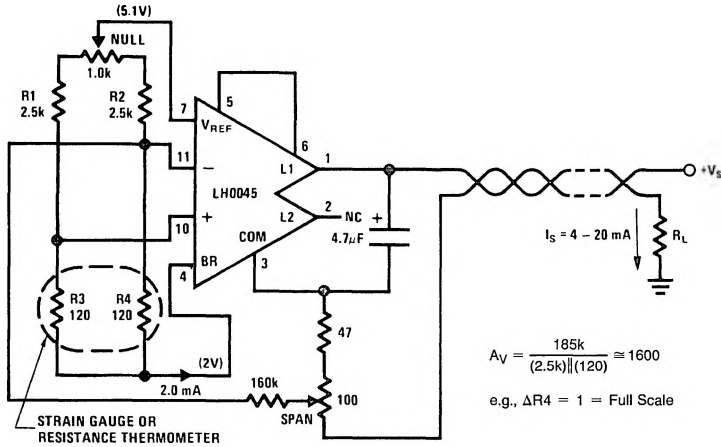

$$A_v = \frac{185k}{(2.5k) \parallel (120)} \approx 1600$$

e.g., $\Delta R4 = 1 =$ Full Scale

TL/K/5556-5

Typical Applications (Continued)

Electronic Temperature Sensor

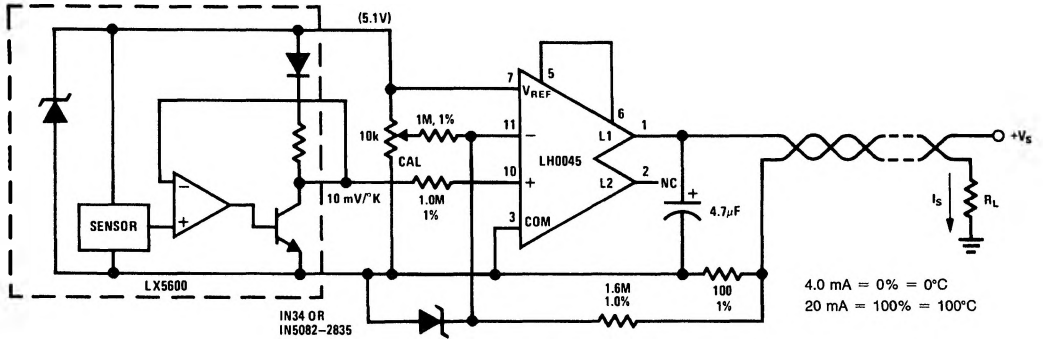

TL/K/5556-6

Remote Sensing Digital Thermometer

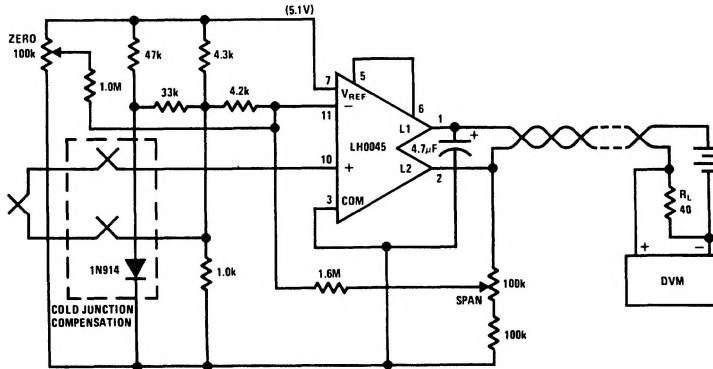

TL/K/5556-7

*All voltages indicated by () are measured with respect to common, pin 3.

Instrumentation Amplifier Transmitter

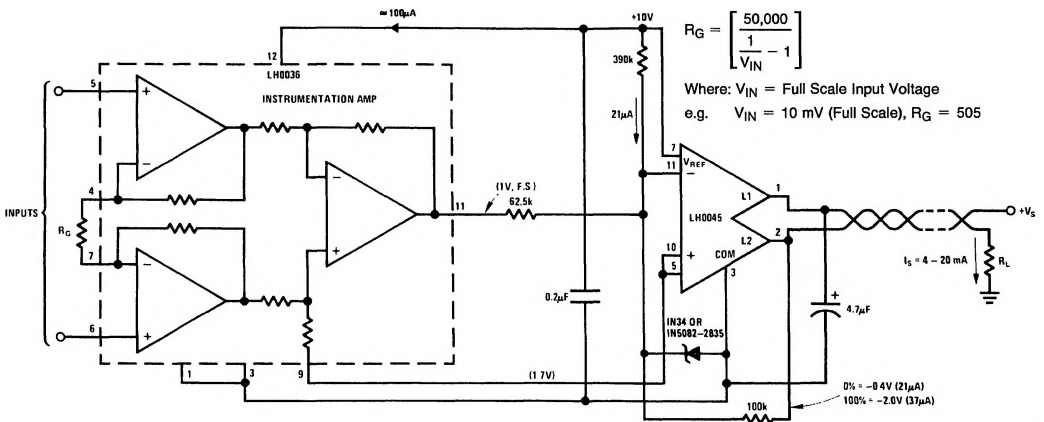

TL/K/5556-8

*All voltages indicated by () are measured with respect to common, pin 3.

Applications Information

CIRCUIT DESCRIPTION AND OPERATION

A simplified schematic of the LH0045/LH0045C is shown in Figure 1. Differential amplifier, A_2 converts very low level signals to an output current via transistor Q_1 . Reference voltage diode D_1 is used to supply voltage for operation of A_2 and to bias an external bridge. Current source I_1 minimizes fluctuation in the bridge reference voltage due to changes in V_S .

In normal operation, the LH0045/LH0045C is used in conjunction with an external bridge comprised of R_{B1} through R_{B4} . The bridge resistors in conjunction with bridge return resistor, R_5 , bias A_2 in its linear region and sense the input signal; e.g. R_{B4} might be a strain sensitive resistor in a strain gauge bridge. R_T is adjusted to purposely unbalance the bridge for 4.0 mA output (null) for zero signal input. This is accomplished by forcing $2.5 \mu\text{A}$ more through R_{B3} than R_{B4} .

The $2.5 \mu\text{A}$ imbalance causes a voltage rise of $(2.5 \mu\text{A}) \times (100\Omega)$ or $250 \mu\text{V}$ at the top of R_{B3} . Terminal L_2 may be viewed as the output of an op amp whose closed loop gain is approximately $R_F/R_{B3} = 1600$.

The $250 \mu\text{V}$ rise at the top of R_{B3} causes a voltage drop of $(1600) \times (250 \mu\text{V})$ or -0.4V across R_9 . An output current, I_S , equal to $0.4\text{V}/R_9$ or 4.0 mA is thus established in Q_1 . If R_{B4} is now decreased by 1.0Ω (due to application of a strain force), a -1.0 mV change in input voltage will result. This causes L_2 to drop to -2.0V . The output current would then be $2.0\text{V}/100\Omega$ or 20 mA (Full Scale). If R_{B3} is a resistor of the same material as R_{B4} but not subjected to the strain, temperature drift effects will be equal in the two legs and will cancel.

In actual practice the loading effects of R_{B2} on the gain (span) and R_F on output current must be taken into account.

THERMAL CONSIDERATIONS

The power output transistor of the LH0045 is thermally isolated from the signal amplifier, A_2 . Nevertheless, a change in the power dissipation will cause a change in the temperature of the package and thus may cause amplifier drift. These temperature excursions may be minimized by careful heat sinking to hold the case temperature equal to the ambient. With the TO-8 (G) package this is best accomplished by a clip-on heat sink such as the Thermalloy #2240A or the Wakefield #215-CB. The case is electrically isolated from the circuit.

In addition, the power change can be minimized by operating the device from relatively high supply voltages in series with a relatively high load resistance. When the signal forces the supply current higher, the voltage across the device will be reduced and the internal power dissipation kept nearly equal to the low current, high voltage condition.

For example, take the case of a 4.0 mA to 20 mA transmitter with a 24V supply and a 100Ω load resistance. The power at 4.0 mA is $(23.6\text{V}) \times (4.0 \text{ mA}) = 94.4 \text{ mW}$ while at full scale the power is $(22\text{V}) \times (20 \text{ mA}) = 440 \text{ mW}$. The net change in power is 345 mW . This change in power will cause a change in temperature and thus a change in offset voltage of A_2 .

If the optimum load resistance of 800Ω (from Figure 2) is used, the power at null is $[24\text{V} - (4.0 \text{ mA}) \times (800\Omega)] (4.0 \text{ mA}) = 83 \text{ mW}$. The power at full scale is $[24\text{V} - (20 \text{ mA}) \times (800\Omega)] (20 \text{ mA}) = 160 \text{ mW}$. The net change is 77 mW . This change is significantly less than without the resistor.

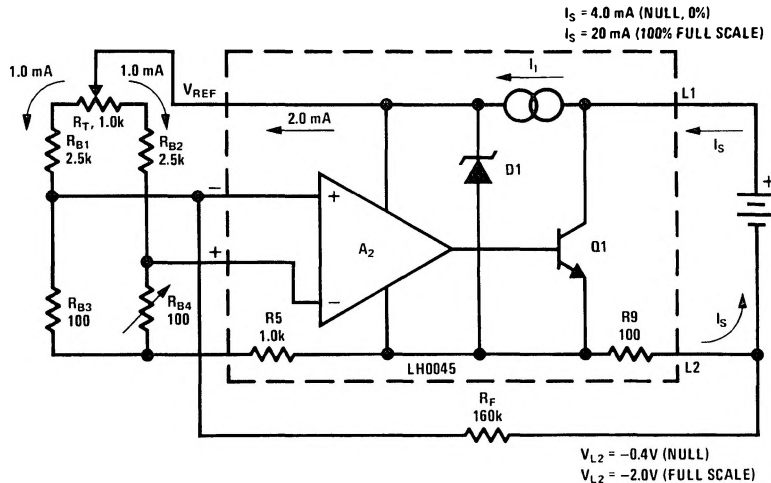
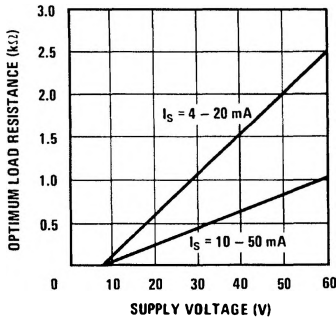

FIGURE 1. LH0045 Simplified Schematic

TL/K/5556-9

Applications Information (Continued)

If the supply voltage is increased to 48V and the load resistance chosen to be the optimum value from *Figure 2* (1.95k), then the power at null is $[48V - (4.0 \text{ mA}) \times (1.95k)] (4.0 \text{ mA}) = 160.8 \text{ mW}$ and the power at full scale is $[48 - (20) \times (1.95k)] (20 \text{ mA}) = 180 \text{ mW}$ for a net change of 19.2 mW.



TL/K/5556-10

FIGURE 2. Optimum Load Resistance vs Supply Voltage

Note that the optimized load resistance is actually the sum of the line resistance, receiver resistances and added external load resistance. However, in many applications the line resistance and receiver resistances are negligible compared to the added external load resistance and thus may be omitted in calculations.

AUXILIARY PINS

The LH0045 has several auxiliary pins designed to provide the user with enhanced flexibility and performance. The following is a discussion of possible uses for these pins.

Programmable V_{REF} —Pins 5 and 6

The LH0045G provides pins 5 and 6 to allow the user to program the value of the reference voltage. The factory trimmed 10V value is obtained by leaving 5 and 6 open. A short between 5 and 6 will program the reference to a nominal 5.1V.

A resistor or pot may be placed between pin 5 and common (pin 3) to obtain reference voltages between 10V and 30V or between pin 5 and pin 7 for reference voltages below 10V. Increased reference voltage might be useful to extend the positive common mode range or to accommodate transducers requiring higher supply voltage. A plot of resistance between pin 5 and pin 3 versus V_{REF} is given in the typical electrical characteristics section. V_{REF} may be adjusted about its nominal value by arranging a pot from V_{REF} to common and feeding a resistor from the wiper into pin 5 so that it may either inject or extract current. Lastly, pin 5 may be used as a nominal 1.7V reference point, if care is taken not to unduly load it with either DC current or capacitance. Obviously, higher supply voltages must be used to obtain the higher reference values. The minimum supply voltage to reference voltage differential is about 4.0V.

Bridge Return

An applications resistor is provided in the LH0045 with a nominal value of 1.0 kΩ. The primary application for the resistor is to maintain the minimum common mode input voltage (1.0V) required by the signal amplifier, A_2 . A typical input application might utilize a strain gauge or thermistor bridge where the resistance of the sensor is 100Ω. Since only 1.0 mA may be drawn from V_{REF} , the 1.0 kΩ bridge return resistor is used to bias A_2 in its linear region as shown in *Figure 3*.

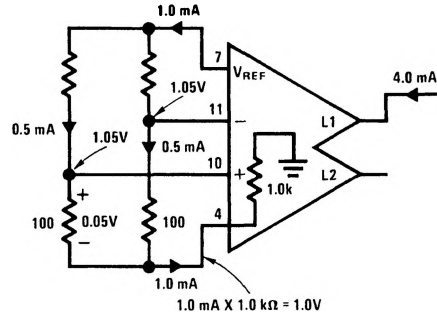

TL/K/5556-11

FIGURE 3. Use of Bridge Return

Over Compensation—Pin 8

Over compensation of the signal amplifier, A_2 , may be desirable in DC applications where the noise-bandwidth must be minimized. A capacitor should be placed between pin 8 and pin 3, common.

Typically,

$$f_{3 \text{ db}} = \frac{1}{2 \pi R (C_1 + C_{EXT})}$$

where:

$R = 400 \text{ M}\Omega$

$C_1 = \text{Internal Compensation Capacitor} = 100 \text{ pF}$

$C_{EXT} = \text{External (overcompensation) Capacitor}$

Input Guard—Pins 9 and 12

Pins 9 and 12 have no internal connection whatever and thus need not be used. In some critical low current applications there may be an advantage to running a guard conductor between the inputs and the adjacent pins to intercept stray leakage currents. Pins 9 and 12 may be connected to this guard to simplify the PC board layout and allow the guard to continue under the device. (See AN-63 for further discussion of guarding techniques.)

NULL AND SPAN ADJUSTMENTS

Most applications of the LH0045 will require potentiometers to trim the initial tolerances of the sensor, the external resistors and the LH0045 itself. The preferred adjustment proce-

Applications Information (Continued)

ture is to stimulate the sensor, alternating between two known values, such as zero and full scale. The span and null are adjusted by monitoring the output current on a chart recorder, meter, or oscilloscope. A full scale stimulus is applied to the sensor and the span potentiometer adjusted for the desired full scale. Then, to adjust the null, apply a zero percent signal to the sensor and adjust the null potentiometer for the desired zero percent current indication.

If it is impractical to cycle the sensor during the calibration procedure, the signal may be simulated electrically with two cautions: 1) the calibration signal must be floating and 2) the calibration thus achieved does not account for sensor inaccuracies and/or errors in the signal generator.

SENSOR SELECTION

Generally it is easiest to use an insulated sensor. If it is necessary to use a grounded sensor, the power supply must be isolated from chassis ground to avoid extraneous circulating currents.

DESIGN EXAMPLE

There are numerous circuit configurations that may be utilized with the LH0045. The following is intended as a general design example which may be extended to specific cases.

Circuit Requirements

Output Characteristics

- 0% = 4.0 mA (NULL)
- 100% = 20 mA (SPAN = 16 mA)
- Supply Voltage = 24V

Input (Sensor) Characteristics

- $V_{IN} = 100$ mV (Full Scale)
- $V_{IN} = 0$ mV (Zero Scale)
- Source Impedance $\leq 1.0\Omega$

General Characteristics

- $0^\circ\text{C} \leq T_A \leq +75^\circ\text{C}$
- Overall Accuracy $\leq 0.5\%$

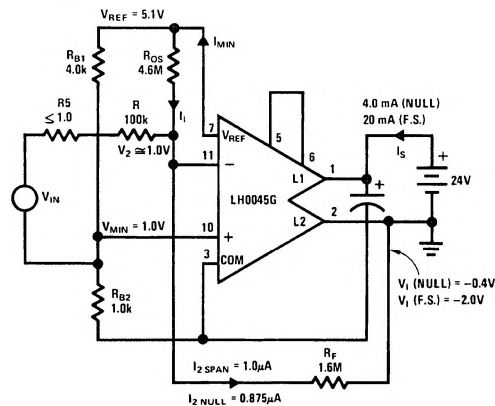

FIGURE 4. Design Example Circuit

TL/K/5556-12

Selection of R_F

Input bias current to the LH0045C is guaranteed less than 10 nA. Furthermore, the change in I_B over the temperature range of interest is typically under 1.0 nA. If I_2 SPAN is selected to be 1.0 μA (1000 ΔI_B) errors due to $\Delta I_B/\Delta T$ will be less than 0.1%. For SPAN = 16 mA.

$$V_{SPAN} = \Delta V_1 = -(16 \text{ mA})(R_9) = -1.6 \text{ V}$$

where R_9 = Internal Current Set Resistor = 100 Ω .

For I_2 SPAN = 1.0 μA ,

$$R_F = \frac{V_{SPAN}}{I_2 \text{ SPAN}} = \frac{-1.6 \text{ V}}{1.0 \mu\text{A}} = 1.6 \text{ M}\Omega$$

$$R_F = 1.6 \text{ M}\Omega$$

Note: For applications with DC gain (ratio of feedback and input resistance) less than 8, it is recommended that a Schottky barrier diode be connected between pin 11 (cathode) and pin 3 (anode). This prevents the possibility of latch up resulting from the inverting input being forced beyond the amplifier supply voltage during power up.

Selection of R_{B1} and R_{B2}

The minimum input common mode voltage, V_{MIN} required at the pin 10 input of A_2 is 1.0V. Furthermore, the maximum open loop supply current (I_{SOL}) drawn by the LH0045 is 3.0 mA. That leaves $I_{MIN} = 4.0 \text{ mA} - 3.0 \text{ mA} = 1.0 \text{ mA}$ left to bias the bridge at null. Hence:

$$R_{B2} \geq \frac{V_{MIN}}{I_{MIN}} = \frac{1.0 \text{ V}}{1.0 \text{ mA}} = 1.0 \text{ k}\Omega$$

And,

$$\frac{V_{REF} R_{B2}}{R_{B1} + R_{B2}} = 1.0 \text{ V}$$

$$R_{B1} = R_{B2} \frac{V_{REF} - 1.0 \text{ V}}{1.0 \text{ V}}$$

$$= 1.0 \text{ k} (5.1 - 1.0)$$

$$R_{B1} \cong 4.0 \text{ k}\Omega$$

Alternatively, an LM113, 1.22V reference diode, or an op amp such as the LM108 may be used to bias the signal amplifier, A_2 , as shown in Figure 5. These techniques have the advantage of lowering the impedance seen at pin 10.

Selection of R_{OS}

R_{OS} is selected to provide the null current of 4.0 mA, $V_1 \text{ NULL} = 4.0 \text{ mA} \times 100\Omega = 0.4 \text{ V}$. From previous calculations we know that $V_{MIN} = 1.0 \text{ V}$. The voltage pin 11, V_2 is:

$$V_2 = V_{MIN} + V_{OS} \cong V_{MIN}$$

for $V_{IN} = 0 \text{ V}$

Hence, the current required to generate the null voltage, $I_2 \text{ NULL}$ is:

$$I_2 \text{ NULL} = \frac{V_{MIN} - V_1 \text{ NULL}}{R_F} \\ = \frac{1.0 \text{ V} - (-0.4 \text{ V})}{1.6 \text{ M}\Omega} = 0.875 \mu\text{A}$$

This current must be provided by R_{OS} from V_{REF} ; hence:

$$R_{OS} = \frac{V_{REF} - V_{MIN}}{I_2 \text{ NULL}}$$

Applications Information (Continued)

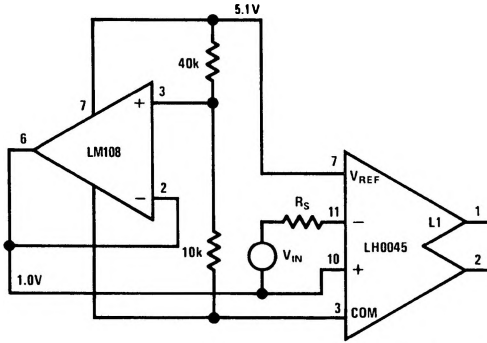

TL/K/5556-13

FIGURE 5. Alternate Biasing Techniques

The nominal value for V_{REF} is 5.1V, therefore the nominal value for R_{OS} is:

$$\frac{5.1V - 1.0V}{0.875 \mu A} \text{ or}$$

$$R_{OS} = 4.6 \text{ M}\Omega$$

It should be noted however, that the variation of V_{REF} may be as high as 5.9V or as low as 4.3V. Furthermore, the tolerances of R_9 (100 Ω), R_{B1} , R_{B2} , and the input V_{OS} of A_2 would predict values for R_{OS} as low as 3.98M and as high as 5.43M. The implication is that in the specific case, R_{OS} should be implemented with a pot, of appropriate value, in order to accommodate the tolerances of V_{REF} , R_9 , V_{OS} , R_{B1} , R_{B2} , etc.

Selection of R

SPAN is required to be 16 mA. From feedback theory and the gain equation we know:

$$I_{SPAN} = V_{IN} \frac{R_F}{R} \times \frac{1}{R_9}$$

where:

R = Total impedance in signal path between pin 10 and pin 11

R_9 = Current setting resistor = 100 Ω

V_{IN} = Full scale input voltage = 100 mV

$$\therefore R = \frac{(V_{IN})(R_F)}{(I_{SPAN})(R_9)}$$

$$R = \frac{(100 \text{ mV})(1.6 \text{ M}\Omega)}{(16 \text{ mA})(100\Omega)}$$

$$R = 100 \text{ k}\Omega$$

As before, uncertainties in device parameters might dictate that R_F be made a pot of appropriate value.

Summary of the Steps to Determine External Resistor Values

1. Select $I_{FULL \text{ SCALE}} = I_{NULL} + I_{SPAN}$ for the desired application. (I_{NULL} is frequently 4.0 mA and $I_{FULL \text{ SCALE}}$ is frequently 20 mA.)

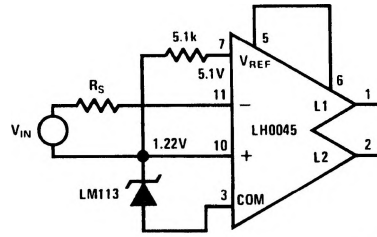

TL/K/5556-14

2. Select $I_2 \text{ SPAN}$ so that it is large compared to ΔI_B . 1000 ΔI_B is a good value.
3. Determine $V_{SPAN} = \Delta V_2 = (I_{SPAN})(R_9)$.
4. Determine $R_F = (V_{SPAN}/I_2 \text{ SPAN})$
5. Select

$$R_{B2} \geq \frac{V_{MIN}}{I_{MIN}}$$

$$R_{B2} \geq \frac{1V}{I_{NULL} - I_{SOL}}$$

Where:

V_{MIN} = minimum common mode input voltage

I_{MIN} = minimum available bridge current

I_{SOL} = maximum open loop supply current

6. Determine
- $$R_{B1} = R_{B2} \frac{V_{REF} - V_{MIN}}{V_{MIN}}$$

7. Determine $V_2 \text{ NULL} = I_{NULL} R_9$

8. Determine

$$I_2 \text{ NULL} = \frac{V_{MIN} - V_2 \text{ NULL}}{R_F}$$

9. Determine

$$R_{OS} = \frac{V_{REF} - V_{MIN}}{I_2 \text{ NULL}}$$

10. Determine

$$R = \frac{(V_{IN})(R_F)}{(I_{SPAN})(R_9)}$$

Where:

V_{IN} = Sensor full scale output voltage

Applications Information (Continued)

ERROR BUDGET ANALYSIS

Errors Due to Change in V_{REF} (ΔV_{REF})

There are several factors which could cause a change in V_{REF} . First, as the ambient temperature changes, a V_{REF} drift of ± 0.2 mV/ $^{\circ}$ C might be expected. Secondly, supply voltage variations could cause a 0.5 mV/V change in V_{REF} . Lastly, self-heating due to power dissipation variations can cause drift of the reference.

An overall expression for change in V_{REF} is:

$$\Delta V_{REF} = \underbrace{[(\theta)(\Delta P_{DISS}) + \Delta T_A] \frac{\Delta V_{REF}}{\Delta T}}_{\text{Thermal Effects}} + \underbrace{\frac{\Delta V_{REF}}{\Delta V_S} (\Delta V_S)}_{\text{Supply Voltage Effects}}$$

Where:

θ = Thermal resistance, either junction-to-ambient or junction-to-case

ΔP_{DISS} = Change in avg. power dissipation

ΔT_A = Change in ambient temperature

$\frac{\Delta V_{REF}}{\Delta T}$ = Reference voltage drift (in mV/ $^{\circ}$ C)

$\frac{\Delta V_{REF}}{\Delta V_S}$ = Line regulation of V_{REF}

Several steps may be taken to minimize the bracketed terms in the equation above. For example, operating the LH0045G with a heat sink reduces the thermal resistance from $\theta_{JA} = 83^{\circ}$ C/W to $\theta_{JC} = 60^{\circ}$ C/W. The ΔP_{DISS} term may be significantly reduced using the power minimization technique described under "Thermal Considerations". For the design example, ΔP_{DISS} is reduced from 384 mW to 77 mW ($R_L = 800\Omega$). Evaluating the LH0045G with a heat sink and $R_L = 800\Omega$ yields.

$$\Delta V_{REF} = \left(\frac{60^{\circ}\text{C}}{\text{W}} (0.077\text{W}) + 75^{\circ}\text{C} \right) \left(\frac{0.2\text{ mV}}{^{\circ}\text{C}} \right) + \frac{0.5\text{ mV}}{\text{V}} (16\text{V})$$

$$\Delta V_{REF} = 24\text{ mV}$$

An expression for error in the output current due to ΔV_{REF} is:

$$\frac{\Delta I_S}{I_{SPAN}} (\%) = 100 \frac{(K)(R_{OS})(\Delta V_{REF}) - (1-K)(\Delta V_{REF})(R_F)}{(R_9)(R_{OS})(I_{SPAN})}$$

Where:

ΔV_{REF} = Total change in V_{REF}

$$K = \frac{R_{B2}}{R_{B1} + R_{B2}}$$

R_9 = Current set resistor

I_{SPAN} = Change in output current from 0% to 100%

For example, $\Delta V_{REF} = 24$ mV, $K = 0.2$, $R_9 = 100\Omega$, $I_{SPAN} = 16$ mA. Hence, a 0.12% worst case error might be expected in output currents due to ΔV_{REF} effects.

Error Due to V_{OS} Drift

One of the primary causes of error in I_S is caused by V_{OS} drift. Drift may be induced either by self heating of the device or ambient temperature changes. The input offset voltage drift, $\Delta V_{OS}/\Delta T$, is nominally 3.3 μ V/ $^{\circ}$ C per millivolt of initial offset. An expression for the total temperature dependent drift is:

$$\Delta V_{OS} = [(\theta)(\Delta P_{DISS}) + \Delta T_A] \frac{\Delta V_{OS}}{\Delta T}$$

Where:

θ = Thermal resistance either junction-to-ambient or junction-to-case

ΔP_{DISS} = Change in average power dissipation

ΔT_A = Change in ambient temperature

The bracketed term may be minimized by heat sinking and using the power minimization technique described under "Thermal Considerations". For the LH0045G design example, $\Delta V_{OS} = 0.352$ mV under ambient conditions and 0.263 mV using a heat sink and $R_L = 800\Omega$.

The error in output current due to ΔV_{OS} is:

$$\begin{aligned} \frac{\Delta I_S}{I_{SPAN}} (\text{in } \%) &= 100 \times \frac{\Delta V_{OS}}{V_{IN} (\text{FULL SCALE})} \\ &= 100 \times \frac{R_F}{(R)(R_9)(I_{SPAN})} \end{aligned}$$

For the design example, $\Delta V_{OS} = 0.263$ mV, V_{IN} (Full Scale) = 100 mV. Hence, 0.26 mV \div 100 mV or 0.26% worst case error could be expected in output current effects.

Errors Due to Changes in R_9

The temperature coefficient of R_9 (TCR) will produce errors in the output current. Changes in R_9 may be caused by self-heating of the device or by ambient temperature changes.

$$\frac{\Delta I_S}{I_{SPAN}} (\text{in } \%) = 100 \frac{\Delta R_9}{\Delta T} (\theta P_{DISS} + \Delta T_A)$$

Where:

θ = Thermal resistance either from junction-to-ambient or junction-to-case

ΔP_{DISS} = Change in average power dissipation

Applications Information (Continued)

ΔT_A = Change in ambient temperature

$$\frac{\Delta R_9}{\Delta T} = \text{TCR of } R_9$$

Using the LH0045G design example, $\Delta R_9/\Delta T = 0.03\%/^{\circ}\text{C}$, hence a 3.2% worst case error in output current might be expected for operation without a heat sink over the temperature range.

Heat sinking the device and using $R_L = 800\Omega$, reduces $\Delta I_S/I_{SPAN}$ to 2.3%.

The error analysis indicates that the internal current set resistor, R_9 , is inadequate to satisfy high accuracy design criterion. In these instances, an external 100Ω resistor should be substituted for R_9 .

Obviously, the TCR of the resistor should be low. Metal film or wire-wound resistors are the best choice offering TCR's less than 10 ppm/ $^{\circ}\text{C}$ versus 50 ppm/ $^{\circ}\text{C}$ typical drift for R_9 .

External Causes of Error

The components external to the LH0045 are also critical in determining errors. Specifically, the composition of resistors R_{B1} , R_{OS} , R_F , R , etc. in the design example will influence both drift and long term stability.

In particular, resistors and potentiometers of wire wound construction are recommended. Also, metal-film resistors with low TCR (≤ 10 ppm/ $^{\circ}\text{C}$) may be used for fixed resistor applications.

Error Analysis Summary

The overall errors attributable to the LH0045 may be minimized using heat sinking, and utilization of an external load resistor. Although R_L reduces the compliance of the circuit, its use is generally advisable in precision applications. External components should be selected for low TCR and long term stability.

The design example errors, using an external 100Ω wire wound resistor for R_9 equal:

$$\frac{\Delta I_S}{I_{SPAN}} = \underbrace{0.12\%}_{\Delta V_{REF}} + \underbrace{0.26\%}_{\Delta V_{OS}} + \underbrace{0.08\%}_{\Delta R_9} = 0.46\%$$

SOCKETS AND HEAT SINKS

Mounting sockets, test sockets and heat sinks are available for the G package.

The following or their equivalents are recommended:

Sockets:

G — 12-Lead TO-8: Barnes Corp. #MGX-12
Textool #212-100-323

Heat Sinks:

G — 12-Lead TO-8: Thermalloy #2240A
Wakefield #215-CB

Definition of Terms

Input Offset Voltage, V_{OS} : The voltage which must be applied between the input terminals through equal resistances to obtain 4.0 mA of supply (output) current.

Input Bias Current, I_B : The average of the two input currents.

Input Offset Current, I_{OS} : The difference in the current into the two input terminals when the supply (output) current is 4.0 mA.

Input Resistance, R_{IN} : The ratio of the change in input voltage to the change in input current at either input with the other input connected to 1.0 V_{DC} .

Open Loop Transconductance, g_{MOL} : The ratio of the supply (output) current $SPAN$ to the input voltage required to produce that $SPAN$.

Open Loop Output Resistance, R_{OUT} : The ratio of a specified supply (output) voltage change to the resulting change in supply (output) current at the specified current level.

Common Mode Rejection Ratio, $CMRR$: The ratio of the change in input offset voltage to the peak-to-peak input voltage range.

Power Supply Rejection Ratio, $PSRR$: The ratio of the change in input offset voltage to the change in supply (output) voltage producing it.

Input Voltage Range, V_{IN} : The range of voltages on the input terminals for which the device operates within specifications.

Open Loop Supply Current, I_S : The supply current required with the signal amplifier A_2 biased off (inverting input positive, non-inverting input negative) and no load on the V_{REF} terminal.

This represents a measure of the minimum low end signal current.

Reference Voltage Line Regulation, $\Delta V_{REF}/\Delta V_S$: The ratio of the change in V_{REF} to the peak-to-peak change in supply (output) voltage producing it.

Reference Voltage Load Regulation, $\Delta V_{REF}/\Delta I_{REF}$: The change in V_{REF} for a stipulated change in I_{REF} .