

LF442A/LF442 Dual Low Power JFET Input Operational Amplifier

General Description

The LF442 dual low power operational amplifiers provide many of the same AC characteristics as the industry standard LM1458 while greatly improving the DC characteristics of the LM1458. The amplifiers have the same bandwidth, slew rate, and gain (10 k Ω load) as the LM1458 and only draw one tenth the supply current of the LM1458. In addition the well matched high voltage JFET input devices of the LF442 reduce the input bias and offset currents by a factor of 10,000 over the LM1458. A combination of careful layout design and internal trimming guarantees very low input offset voltage and voltage drift. The LF442 also has a very low equivalent input noise voltage for a low power amplifier.

The LF442 is pin compatible with the LM1458 allowing an immediate 10 times reduction in power drain in many applications. The LF442 should be used where low power dissipation and good electrical characteristics are the major considerations.

Features

- $\frac{1}{10}$ supply current of a LM1458 400 μ A (max)
- Low input bias current 50 pA (max)
- Low input offset voltage 1 mV (max)
- Low input offset voltage drift 10 μ V/ $^{\circ}$ C (max)
- High gain bandwidth 1 MHz
- High slew rate 1 V/ μ s
- Low noise voltage for low power 35 nV/ \sqrt Hz
- Low input noise current 0.01 pA/ \sqrt Hz
- High input impedance 10¹² Ω
- High gain $V_O = \pm 10V, R_L = 10k$ 50k (min)

Typical Connection

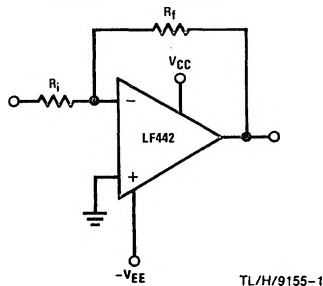

Ordering Information

LF442XYZ

- X indicates electrical grade
- Y indicates temperature range
- "M" for military
- "C" for commercial
- Z indicates package type
- "H" or "N"

Connection Diagrams

Metal Can Package

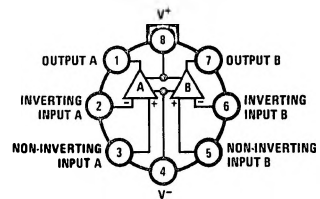

TL/H/9155-2

Top View

Note: Pin 4 connected to case

Order Number LF442AMH, LF442ACH
or LF442CH

See NS Package Number H08B

Simplified Schematic

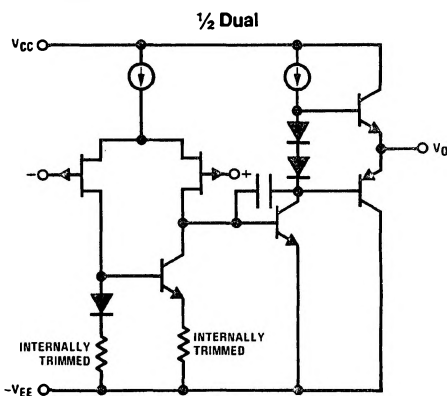

Dual-In-Line Package

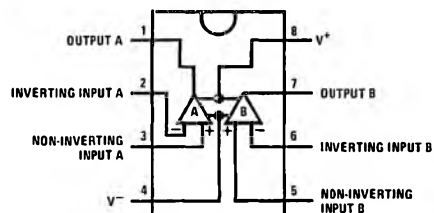

TL/H/9155-4

Top View

Order Number LF442CJ, LF442ACN or LF442CN
See NS Package Number J08A or N08E

Absolute Maximum Ratings

If Military/Aerospace specified devices are required, please contact the National Semiconductor Sales Office/Distributors for availability and specifications. (Note 9)

	LF442A	LF442
Supply Voltage	±22V	±18V
Differential Input Voltage	±38V	±30V
Input Voltage Range (Note 1)	±19V	±15V
Output Short Circuit Duration (Note 2)	Continuous	Continuous

	H Package	N Package
T _J max	150°C	115°C
θ _{JA} (Typical) (Note 3)	65°C/W	114°C/W
(Note 4)	165°C/W	152°C/W
θ _{JC} (Typical)	21°C/W	
Operating Temperature Range	(Note 4)	(Note 4)
Storage Temperature Range	-65°C ≤ T _A ≤ 150°C	-65°C ≤ T _A ≤ 150°C
Lead Temperature (Soldering, 10 seconds)	260°C	260°C

ESD rating to be determined.

DC Electrical Characteristics (Note 6)

Symbol	Parameter	Conditions	LF442A			LF442			Units	
			Min	Typ	Max	Min	Typ	Max		
V _{OS}	Input Offset Voltage	R _S = 10 kΩ, T _A = 25°C		0.5	1.0		1.0	5.0	mV	
		Over Temperature						7.5	mV	
ΔV _{OS} /ΔT	Average TC of Input Offset Voltage	R _S = 10 kΩ		7	10		7		μV/°C	
I _{OS}	Input Offset Current	V _S = ±15V (Notes 6 and 7)	T _J = 25°C		5	25		5	50	pA
			T _J = 70°C			1.5			1.5	nA
			T _J = 125°C			10				nA
I _B	Input Bias Current	V _S = ±15V (Notes 6 and 7)	T _J = 25°C		10	50		10	100	pA
			T _J = 70°C			3			3	nA
			T _J = 125°C			20				nA
R _{IN}	Input Resistance	T _J = 25°C		10 ¹²			10 ¹²		Ω	
A _{VOL}	Large Signal Voltage Gain	V _S = ±15V, V _O = ±10V, R _L = 10 kΩ, T _A = 25°C	50	200		25	200		V/mV	
		Over Temperature	25	200		15	200		V/mV	
V _O	Output Voltage Swing	V _S = ±15V, R _L = 10 kΩ	±12	±13		±12	±13		V	
V _{CM}	Input Common-Mode Voltage Range		±16	+18 -17		±11	+14 -12		V V	
CMRR	Common-Mode Rejection Ratio	R _S ≤ 10 kΩ	80	100		70	95		dB	
PSRR	Supply Voltage Rejection Ratio	(Note 8)	80	100		70	90		dB	
I _S	Supply Current			300	400		400	500	μA	

AC Electrical Characteristics (Note 6)

Symbol	Parameter	Conditions	LF442A			LF442			Units
			Min	Typ	Max	Min	Typ	Max	
	Amplifier to Amplifier Coupling	$T_A = 25^\circ\text{C}$, $f = 1\text{ Hz-20 kHz}$ (Input Referred)		-120			-120		dB
SR	Slew Rate	$V_S = \pm 15\text{V}$, $T_A = 25^\circ\text{C}$	0.8	1		0.6	1		V/ μs
GBW	Gain-Bandwidth Product	$V_S = \pm 15\text{V}$, $T_A = 25^\circ\text{C}$	0.8	1		0.6	1		MHz
e_n	Equivalent Input Noise Voltage	$T_A = 25^\circ\text{C}$, $R_S = 100\Omega$, $f = 1\text{ kHz}$		35			35		nV/ $\sqrt{\text{Hz}}$
i_n	Equivalent Input Noise Current	$T_A = 25^\circ\text{C}$, $f = 1\text{ kHz}$		0.01			0.01		pA/ $\sqrt{\text{Hz}}$

Note 1: Unless otherwise specified the absolute maximum negative input voltage is equal to the negative power supply voltage.

Note 2: Any of the amplifier outputs can be shorted to ground indefinitely, however, more than one should not be simultaneously shorted as the maximum junction temperature will be exceeded.

Note 3: The value given is in 400 linear feet/min air flow.

Note 4: The value given is in static air.

Note 5: These devices are available in both the commercial temperature range $0^\circ\text{C} \leq T_A \leq 70^\circ\text{C}$ and the military temperature range $-55^\circ\text{C} \leq T_A \leq 125^\circ\text{C}$. The temperature range is designated by the position just before the package type in the device number. A "C" indicates the commercial temperature range and an "M" indicates the military temperature range. The military temperature range is available in "H" package only.

Note 6: Unless otherwise specified, the specifications apply over the full temperature range and for $V_S = \pm 20\text{V}$ for the LF442A and for $V_S = \pm 15\text{V}$ for the LF442. V_{OS} , I_B , and I_{OS} are measured at $V_{CM} = 0$.

Note 7: The input bias currents are junction leakage currents which approximately double for every 10°C increase in the junction temperature, T_J . Due to limited production test time, the input bias currents measured are correlated to junction temperature. In normal operation the junction temperature rises above the ambient temperature as a result of internal power dissipation, P_D . $T_J = T_A + \theta_{JA}P_D$ where θ_{JA} is the thermal resistance from junction to ambient. Use of a heat sink is recommended if input bias current is to be kept to a minimum.

Note 8: Supply voltage rejection ratio is measured for both supply magnitudes increasing or decreasing simultaneously in accordance with common practice from $\pm 15\text{V}$ to $\pm 5\text{V}$ for the LF442 and $\pm 20\text{V}$ to $\pm 5\text{V}$ for the LF442A.

Note 9: Refer to RETS442AX for LF442AMH military specifications and to RETS442X for LF442MH military specifications.

Typical Performance Characteristics

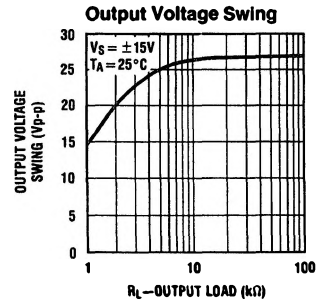
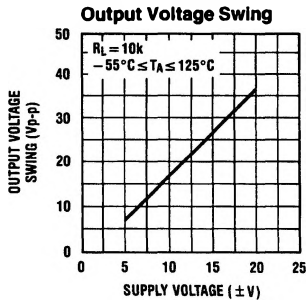
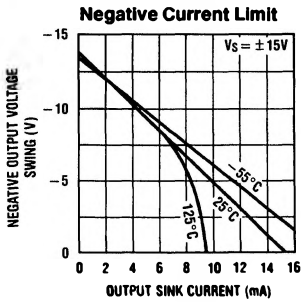
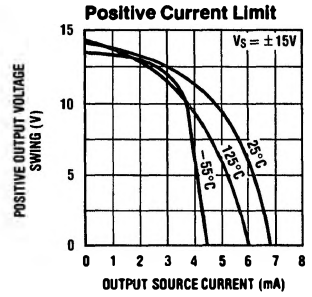
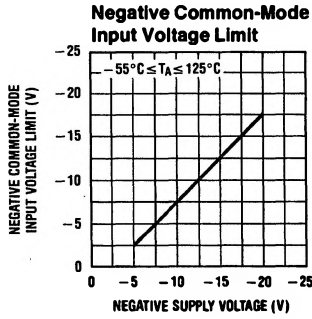
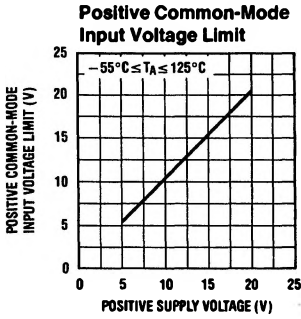
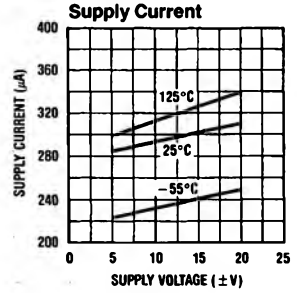
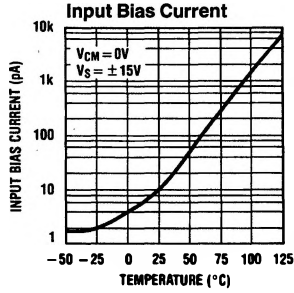
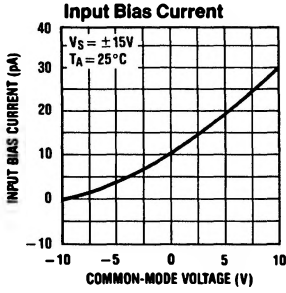

TL/H/9155-5

Typical Performance Characteristics (Continued)

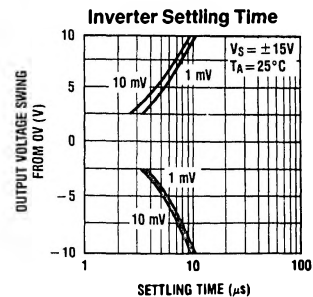
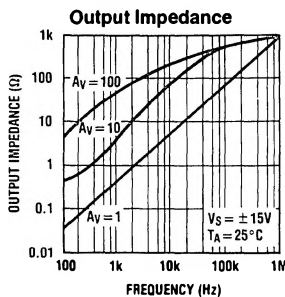
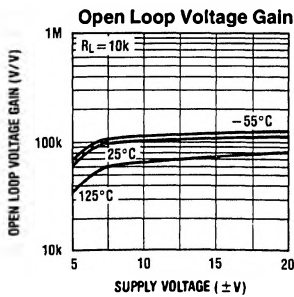
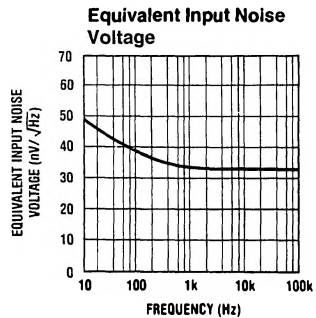
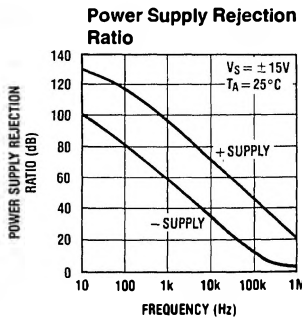
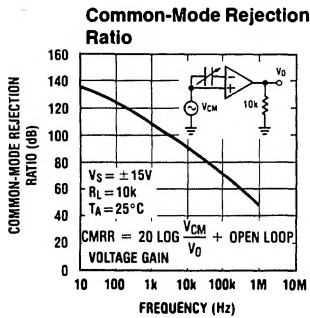
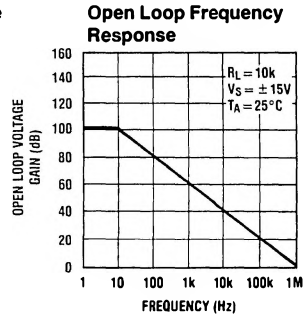
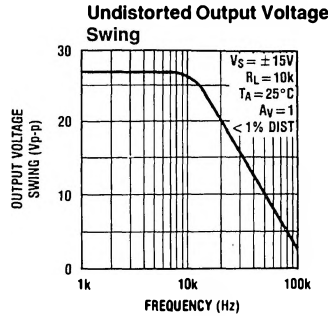
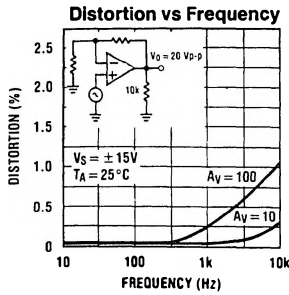
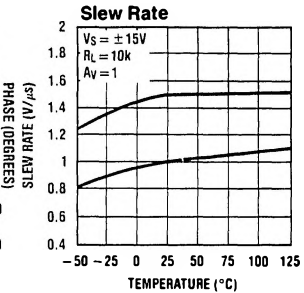
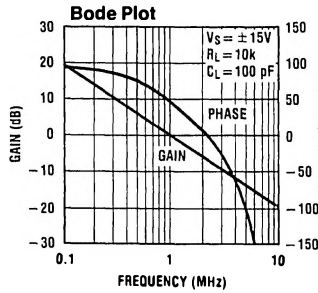
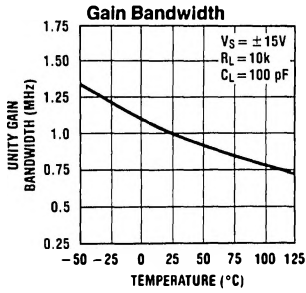

Pulse Response $R_L = 10\text{ k}\Omega$, $C_L = 10\text{ pF}$

Small Signal Inverting

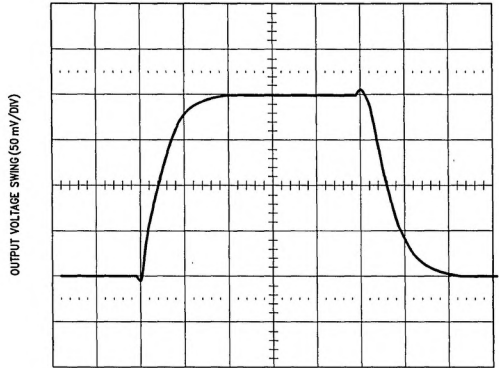

TL/H/9155-7

Small Signal Non-Inverting

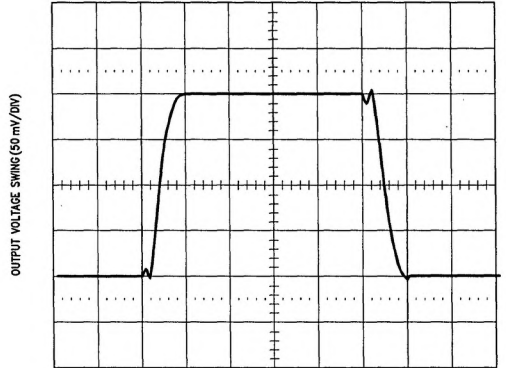

TIME (0.5 μs /DIV)

TL/H/9155-8

Large Signal Inverting

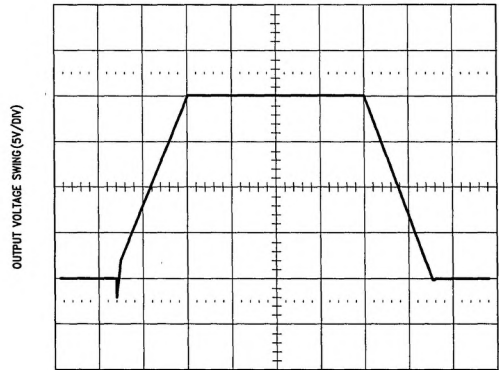

TIME (10 μs /DIV)

TL/H/9155-9

Large Signal Non-Inverting

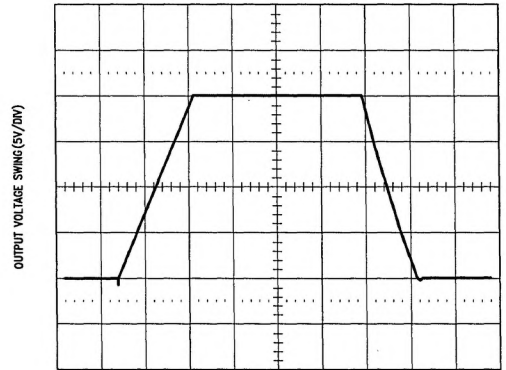

TIME (10 μs /DIV)

TL/H/9155-10

Application Hints

This device is a dual low power op amp with internally trimmed input offset voltages and JFET input devices (BI-FET II). These JFETs have large reverse breakdown voltages from gate to source and drain eliminating the need for clamps across the inputs. Therefore, large differential input voltages can easily be accommodated without a large increase in input current. The maximum differential input voltage is independent of the supply voltages. However, neither of the input voltages should be allowed to exceed the negative supply as this will cause large currents to flow which can result in a destroyed unit.

Exceeding the negative common-mode limit on either input will force the output to a high state, potentially causing a reversal of phase to the output. Exceeding the negative common-mode limit on both inputs will force the amplifier output to a high state. In neither case does a latch occur since raising the input back within the common-mode range again puts the input stage and thus the amplifier in a normal operating mode.

Exceeding the positive common-mode limit on a single input will not change the phase of the output; however, if both inputs exceed the limit, the output of the amplifier will be forced to a high state.

The amplifiers will operate with a common-mode input voltage equal to the positive supply; however, the gain bandwidth and slew rate may be decreased in this condition. When the negative common-mode voltage swings to within 3V of the negative supply, an increase in input offset voltage may occur.

Each amplifier is individually biased to allow normal circuit operation with power supplies of $\pm 3.0V$. Supply voltages less than these may degrade the common-mode rejection and restrict the output voltage swing.

The amplifiers will drive a 10 k Ω load resistance to $\pm 10V$ over the full temperature range.

Precautions should be taken to ensure that the power supply for the integrated circuit never becomes reversed in polarity or that the unit is not inadvertently installed backwards in a socket as an unlimited current surge through the resulting forward diode within the IC could cause fusing of the internal conductors and result in a destroyed unit.

Because these amplifiers are JFET rather than MOSFET input op amps they do not require special handling.

As with most amplifiers, care should be taken with lead dress, component placement and supply decoupling in order to ensure stability. For example, resistors from the output to an input should be placed with the body close to the input to minimize "pick-up" and maximize the frequency of the feedback pole by minimizing the capacitance from the input to ground.

A feedback pole is created when the feedback around a single amplifier is resistive. The parallel resistance and capacitance from the input of the device (usually the inverting input) to AC ground set the frequency of the pole. In many instances the frequency of this pole is much greater than the expected 3 dB frequency of the closed loop gain and consequently there is negligible effect on stability margin. However, if the feedback pole is less than approximately 6 times the expected 3 dB frequency a lead capacitor should be placed from the output to the input of the op amp. The value of the added capacitor should be such that the RC time constant of this capacitor and the resistance it parallels is greater than or equal to the original feedback pole time constant.

Typical Applications

Battery Powered Strip Chart Preamplifier

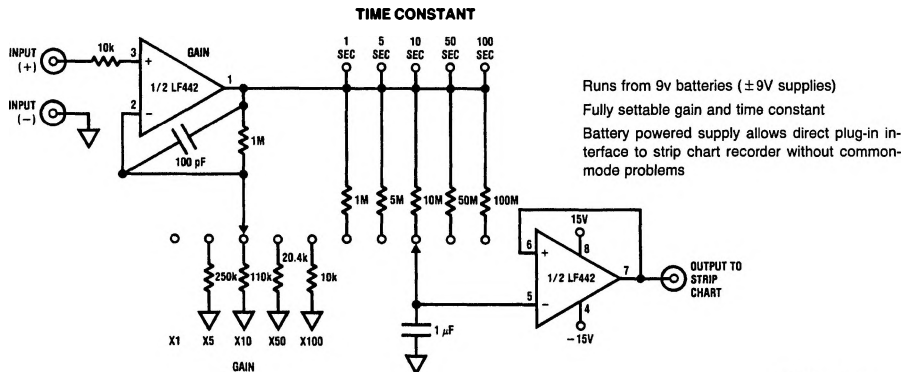

TL/H/9155-11

Typical Applications (Continued)

"No FET" Low Power V → F Converter

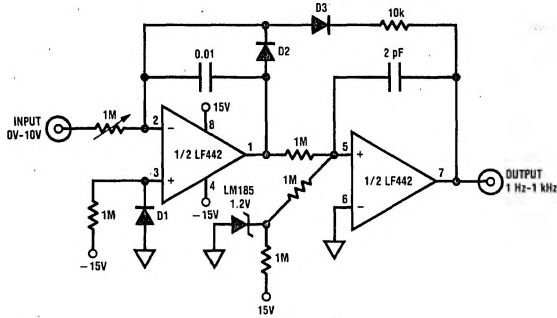

Trim 1M pot for 1 kHz full-scale output
 15 mW power drain
 No integrator reset FET required
 Mount D1 and D2 in close proximity,
 1% linearity to 1 kHz

TL/H/9155-12

High Efficiency Crystal Oven Controller

- $T_{control} = 75^{\circ}C$
- A1's output represents the amplified difference between the LM335 temperature sensor and the crystal oven's temperature
- A2, a free running duty cycle modulator, drives the LM395 to complete a servo loop
- Switched mode operation yields high efficiency
- 1% metal film resistor

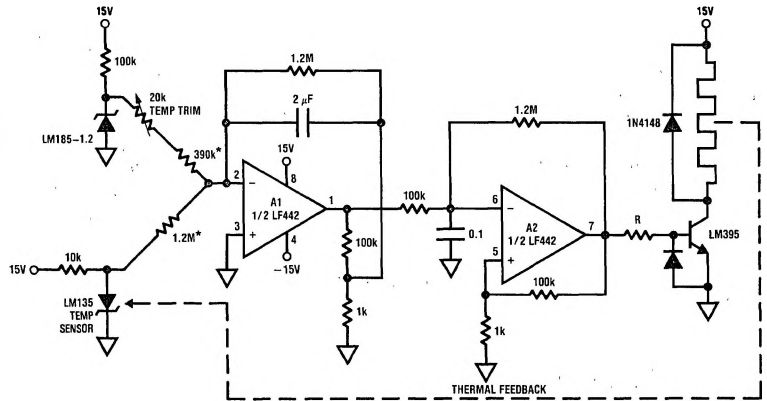

TL/H/9155-13

Conventional Log Amplifier

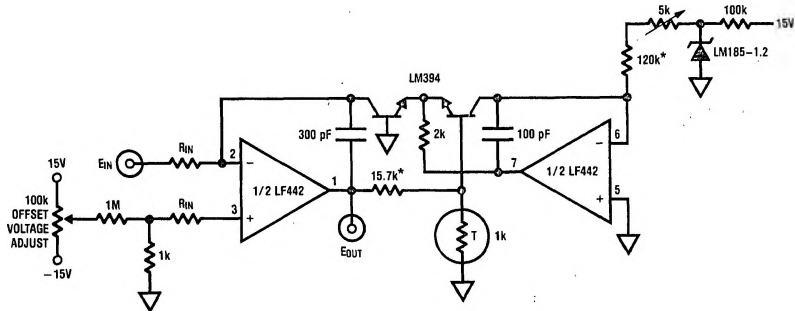

TL/H/9155-14

$$E_{OUT} = - \left[\log_{10} \left(\frac{E_{IN}}{R_{IN}} \right) + 5 \right]$$

R_T = Tel Labs type Q81

Trim 5k for 10 μA through the 5k-120k combination

*1% film resistor

Typical Applications (Continued)

Unconventional Log Amplifier

Q1, Q2, Q3 are included on LM389 amplifier chip which is temperature-stabilized by the LM389 and Q2-Q3, which act as a heater-sensor pair. Q1, the logging transistor, is thus immune to ambient temperature variation and requires no temperature compensation at all.

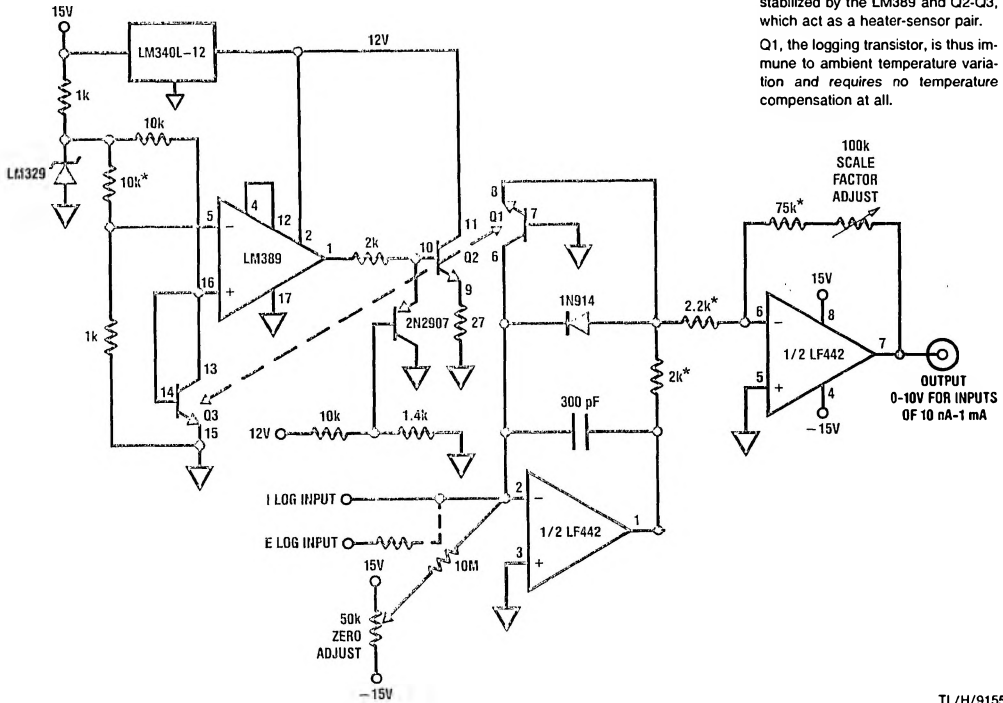

TL/H/9155-15

Detailed Schematic

1/2 Dual

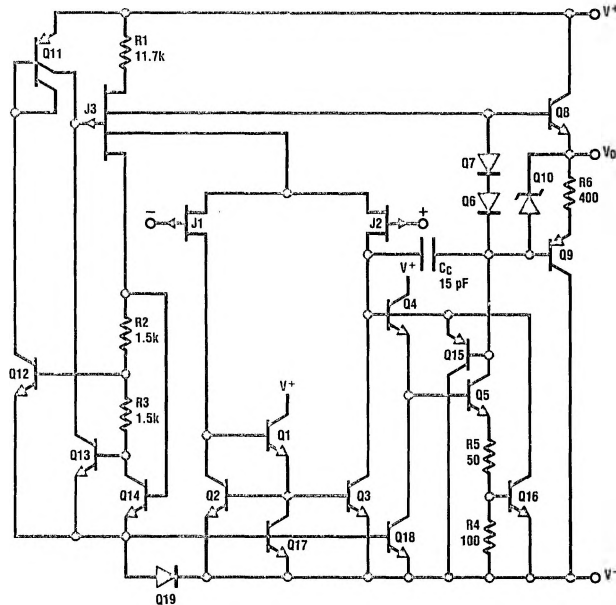

TL/H/9155-16