



## Absolute Maximum Ratings

If Military/Aerospace specified devices are required, please contact the National Semiconductor Sales Office/Distributors for availability and specifications. (Note 1)

Supply Voltage ( $V_{CC} - V_{EE}$ )	36V
Reference Voltage	$V_{EE} \leq V_R \leq V_{CC}$
Logic Input Voltage	$V_R - 4.0V \leq V_{IN} \leq V_R + 6.0V$
Analog Voltage	$V_{EE} \leq V_A \leq V_{CC} + 6V$ $V_A \leq V_{EE} + 36V$
Analog Current	$ I_A  < 20 \text{ mA}$

Power Dissipation (Note 2)	
Molded DIP (N Suffix)	500 mW
Cavity DIP (D Suffix)	900 mW
Operating Temperature Range	
LF11201, 2 and LF11331, 2, 3	-55°C to +125°C
LF13201, 2 and LF13331, 2, 3	0°C to +70°C
Storage Temperature	-65°C to +150°C
Soldering Information	
N and D Package (10 sec.)	300°C
SO Package	
Vapor Phase (60 sec.)	215°C
Infrared (15 sec.)	220°C

## Electrical Characteristics (Note 3)

Symbol	Parameter	Conditions	LF11331/2/3 LF11201/2			LF13331/2/3 LF13201/2			Units
			Min	Typ	Max	Min	Typ	Max	
$R_{ON}$	"ON" Resistance	$V_A = 0, I_D = 1 \text{ mA}$ $T_A = 25^\circ\text{C}$		150	200		150	250	$\Omega$
$R_{ON \text{ Match}}$	"ON" Resistance Matching	$T_A = 25^\circ\text{C}$		200	300		200	350	$\Omega$
$V_A$	Analog Range			5	20		10	50	$\Omega$
$I_{S(ON)} + I_{D(ON)}$	Leakage Current in "ON" Condition	Switch "ON," $V_S = V_D = \pm 10V$ $T_A = 25^\circ\text{C}$	$\pm 10$	$\pm 11$		$\pm 10$	$\pm 11$		V
$I_{S(OFF)}$	Source Current in "OFF" Condition	Switch "OFF," $V_S = +10V$ , $V_D = -10V$ $T_A = 25^\circ\text{C}$		0.3	5		0.3	10	nA
$I_{D(OFF)}$	Drain Current in "OFF" Condition	Switch "OFF," $V_S = +10V$ , $V_D = -10V$ $T_A = 25^\circ\text{C}$		3	100		3	30	nA
$V_{INH}$	Logical "1" Input Voltage		2.0			2.0			V
$V_{INL}$	Logical "0" Input Voltage			0.8			0.8		V
$I_{INH}$	Logical "1" Input Current	$V_{IN} = 5V$ $T_A = 25^\circ\text{C}$		3.6	10		3.6	40	$\mu\text{A}$
$I_{INL}$	Logical "0" Input Current	$V_{IN} = 0.8$ $T_A = 25^\circ\text{C}$			25			100	$\mu\text{A}$
$t_{ON}$	Delay Time "ON"	$V_S = \pm 10V$ , (Figure 3) $T_A = 25^\circ\text{C}$		500			500		ns
$t_{OFF}$	Delay Time "OFF"	$V_S = \pm 10V$ , (Figure 3) $T_A = 25^\circ\text{C}$		90			90		ns
$t_{ON} - t_{OFF}$	Break-Before-Make	$V_S = \pm 10V$ , (Figure 3) $T_A = 25^\circ\text{C}$		80			80		ns
$C_{S(OFF)}$	Source Capacitance	Switch "OFF," $V_S = \pm 10V$ $T_A = 25^\circ\text{C}$		4.0			4.0		pF
$C_{D(OFF)}$	Drain Capacitance	Switch "OFF," $V_D = \pm 10V$ $T_A = 25^\circ\text{C}$		3.0			3.0		pF
$C_{S(ON)} + C_{D(ON)}$	Active Source and Drain Capacitance	Switch "ON," $V_S = V_D = 0V$ $T_A = 25^\circ\text{C}$		5.0			5.0		pF
$I_{SO(OFF)}$	"OFF" Isolation	(Figure 4), (Note 4) $T_A = 25^\circ\text{C}$		-50			-50		dB
CT	Crosstalk	(Figure 4), (Note 4) $T_A = 25^\circ\text{C}$		-65			-65		dB
SR	Analog Slew Rate	(Note 5) $T_A = 25^\circ\text{C}$		50			50		V/ $\mu\text{s}$
$I_{DIS}$	Disable Current	(Figure 5), (Note 6) $T_A = 25^\circ\text{C}$		0.4	1.0		0.6	1.5	mA
				0.6	1.5		0.9	2.3	mA
$I_{EE}$	Negative Supply Current	All Switches "OFF," $V_S = \pm 10V$ $T_A = 25^\circ\text{C}$		3.0	5.0		4.3	7.0	mA
				4.2	7.5		6.0	10.5	mA
$I_R$	Reference Supply Current	All Switches "OFF," $V_S = \pm 10V$ $T_A = 25^\circ\text{C}$		2.0	4.0		2.7	5.0	mA
				2.8	6.0		3.8	7.5	mA
$I_{CC}$	Positive Supply Current	All Switches "OFF," $V_S = \pm 10V$ $T_A = 25^\circ\text{C}$		4.5	6.0		7.0	9.0	mA
				6.3	9.0		9.8	13.5	mA

**Note 1:** Refer to RETSF11201X, RETSF11331X, RETSF11332X and RETSF11333X for military specifications.

**Note 2:** For operating at high temperature the molded DIP products must be derated based on a +100°C maximum junction temperature and a thermal resistance of +150°C/W, devices in the cavity DIP are based on a +150°C maximum junction temperature and are derated at +100°C/W.

**Note 3:** Unless otherwise specified,  $V_{CC} = +15V$ ,  $V_{EE} = -15V$ ,  $V_R = 0V$ , and limits apply for  $-55^\circ\text{C} \leq T_A \leq +125^\circ\text{C}$  for the LF11331/2/3 and the LF11201/2,  $-25^\circ\text{C} \leq T_A \leq +85^\circ\text{C}$  for the LF13331/2/3 and the LF13201/2.

**Note 4:** These parameters are limited by the pin to pin capacitance of the package.

**Note 5:** This is the analog signal slew rate above which the signal is distorted as a result of finite internal slew rates.

**Note 6:** All switches in the device are turned "OFF" by saturating a transistor at the disable node as shown in Figure 5. The delay time will be approximately equal to the  $t_{ON}$  or  $t_{OFF}$  plus the delay introduced by the external transistor.

**Note 7:** This graph indicates the analog current at which 1% of the analog current is lost when the drain is positive with respect to the source.

**Note 8:**  $\theta_{JA}$  (Typical) Thermal Resistance

Molded DIP (N)	85°C/W
Cavity DIP (D)	100°C/W
Small Outline (M)	105°C/W

**Connection Diagrams** (Top View for SO and Dual-In-Line Packages) (All Switches Shown are For Logical "0")

**LF11331/LF13331**

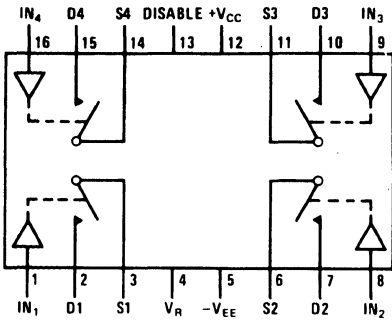

TL/H/5667-1

**LF11332/LF13332**

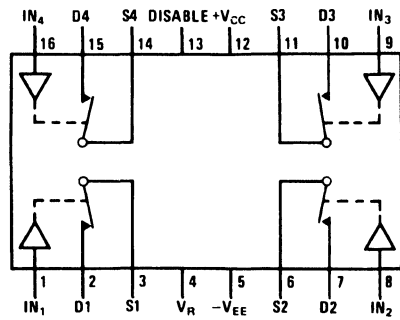

TL/H/5667-13

**LF11333/LF13333**

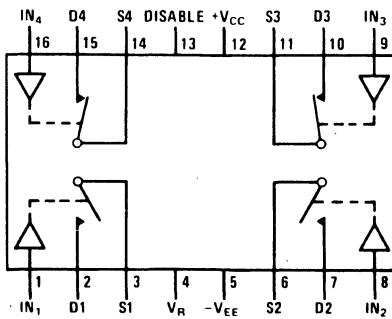

TL/H/5667-14

**LF11201/LF13201**

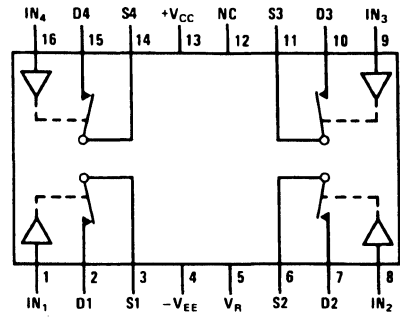

TL/H/5667-15

**LF11202/LF13202**

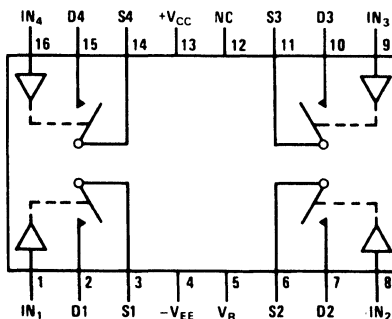

TL/H/5667-16

**Order Number LF13201D, LF11201D, LF13202D, LF11202D, LF13331D, LF11331D, LF13332D, LF11332D, LF13333D or LF11333D**

**See NS Package Number D16C**

**Order Number LF13201M, LF13202M, LF13331M, LF13332M or LF13333M**

**See NS Package Number M16A**

**Order Number LF13201N, LF13202N, LF13331N, LF13332N or LF13333N**

**See NS Package Number N16A**

# Test Circuit and Typical Performance Curves

Delay Time, Rise Time, Settling Time, and Switching Transients

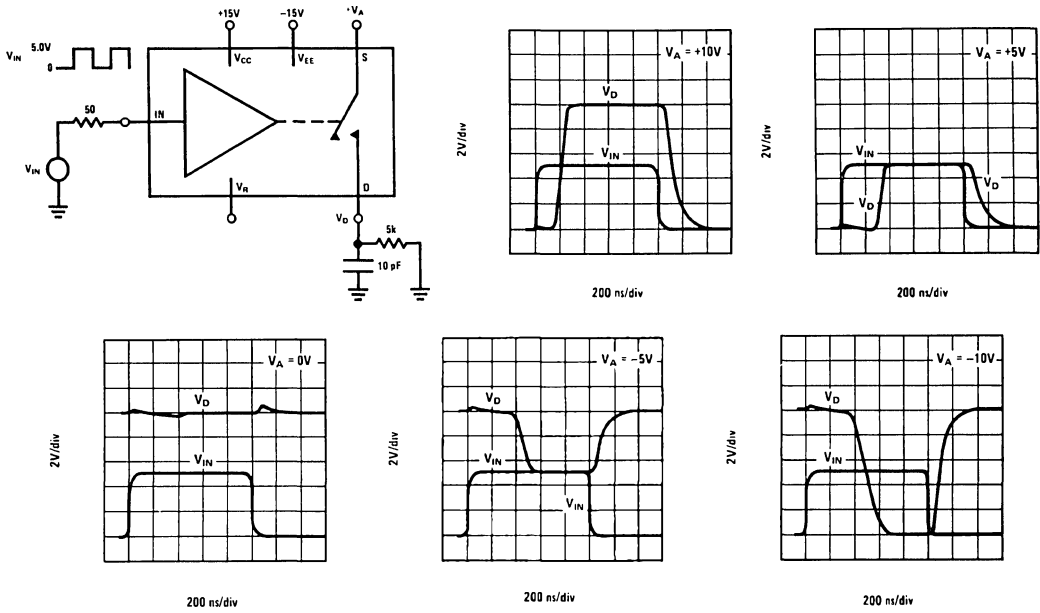

TL/H/5667-3

## Additional Test Circuits

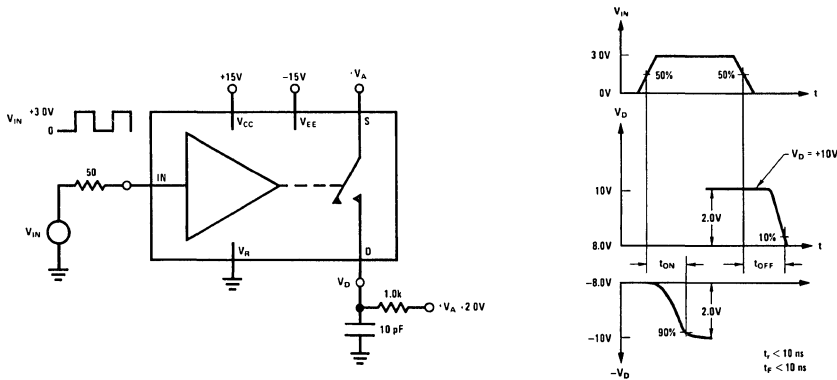

FIGURE 3.  $t_{ON}$ ,  $t_{OFF}$  Test Circuit and Waveforms for a Normally Open Switch

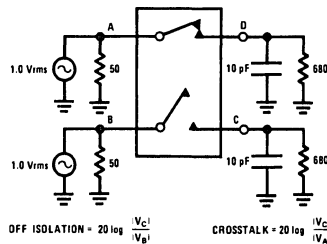
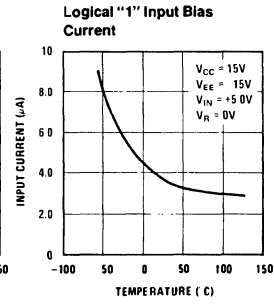
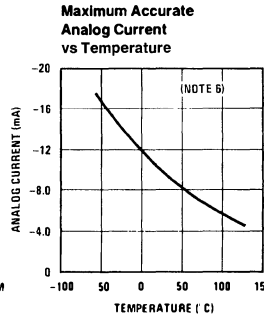
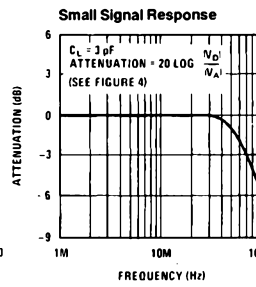
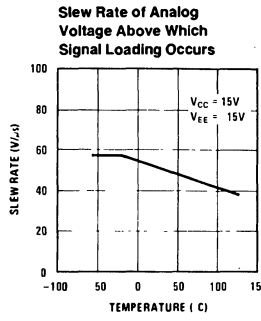
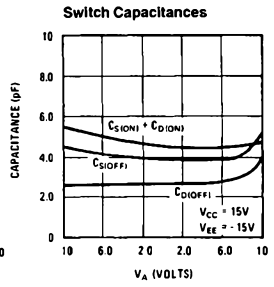
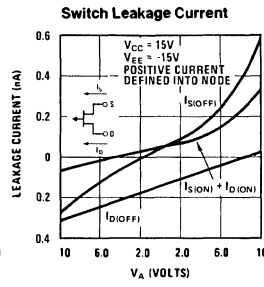
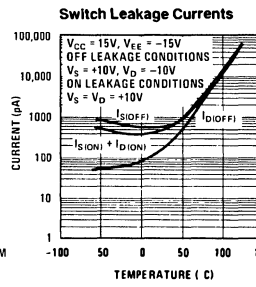
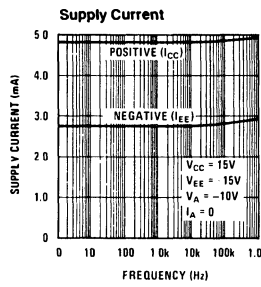
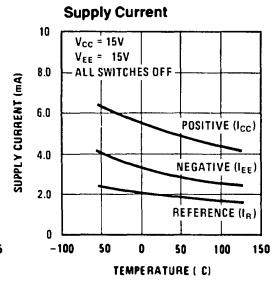
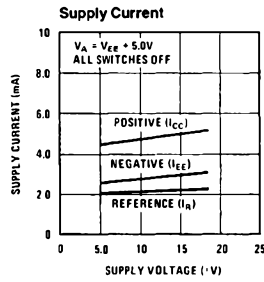
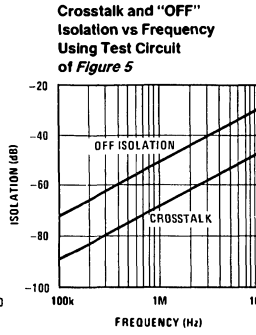
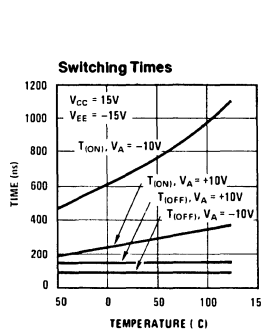
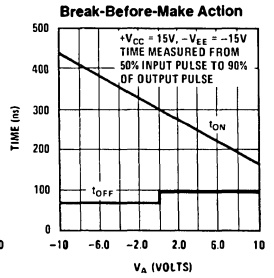
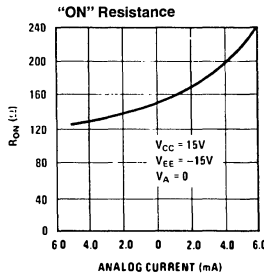
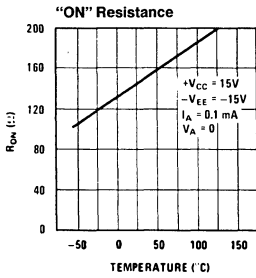
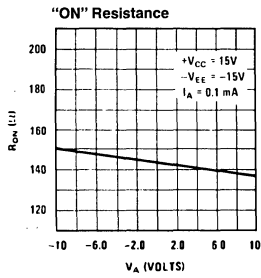

FIGURE 4. "OFF" Isolation, Crosstalk, Small Signal Response

TL/H/5667-4

# Typical Performance Characteristics



## Application Hints

### GENERAL INFORMATION

These devices are monolithic quad JFET analog switches with "ON" resistances which are essentially independent of analog voltage or analog current. The leakage currents are typically less than 1 nA at 25°C in both the "OFF" and "ON" switch states and introduce negligible errors in most applications. Each switch is controlled by minimum TTL logic levels at its input and is designed to turn "OFF" faster than it will turn "ON." This prevents two analog sources from being transiently connected together during switching. The switches were designed for applications which require break-before-make action, no analog current loss, medium speed switching times and moderate analog currents.

Because these analog switches are JFET rather than CMOS, they do not require special handling.

### LOGIC INPUTS

The logic input (IN), of each switch, is referenced to two forward diode drops (1.4V at 25°C) from the reference supply ( $V_R$ ) which makes it compatible with DTL, RTL, and TTL logic families. For normal operation, the logic "0" voltage can range from 0.8V to -4.0V with respect to  $V_R$  and the logic "1" voltage can range from 2.0V to 6.0V with respect to  $V_R$ , provided  $V_{IN}$  is not greater than ( $V_{CC} - 2.5V$ ). If the input voltage is greater than ( $V_{CC} - 2.5V$ ), the input current will increase. If the input voltage exceeds 6.0V or -4.0V with respect to  $V_R$ , a resistor in series with the input should be used to limit the input current to less than 100 $\mu$ A.

### ANALOG VOLTAGE AND CURRENT

#### Analog Voltage

Each switch has a constant "ON" resistance ( $R_{ON}$ ) for analog voltages from ( $V_{EE} + 5V$ ) to ( $V_{CC} - 5V$ ). For analog voltages greater than ( $V_{CC} - 5V$ ), the switch will remain ON independent of the logic input voltage. For analog voltages less than ( $V_{EE} + 5V$ ), the ON resistance of the switch will increase. Although the switch will not operate normally when the analog voltage is out of the previously mentioned range, the source voltage can go to either ( $V_{EE} + 36V$ ) or ( $V_{CC} + 6V$ ), whichever is more positive, and can go as negative as  $V_{EE}$  without destruction. The drain (D) voltage can also go to either ( $V_{EE} + 36V$ ) or ( $V_{CC} + 6V$ ), whichever is more positive, and can go as negative as ( $V_{CC} - 36V$ ) without destruction.

#### Analog Current

With the source (S) positive with respect to the drain (D), the  $R_{ON}$  is constant for low analog currents, but will increase at higher currents (>5 mA) when the FET enters the saturation region. However, if the drain is positive with respect to the source and a small analog current loss at high analog currents (Note 6) is tolerable, a low  $R_{ON}$  can be maintained for analog currents greater than 5 mA at 25°C.

### LEAKAGE CURRENTS

The drain and source leakage currents, in both the ON and the OFF states of each switch, are typically less than 1 nA at 25°C and less than 100 nA at 125°C. As shown in the typical curves, these leakage currents are dependent on power supply voltages, analog voltage, analog current and the source to drain voltage.

### DELAY TIMES

The delay time OFF ( $t_{OFF}$ ) is essentially independent of both the analog voltage and temperature. The delay time ON ( $t_{ON}$ ) will decrease as either ( $V_{CC} - V_A$ ) decreases or the temperature decreases.

### POWER SUPPLIES

The voltage between the positive supply ( $V_{CC}$ ) and either the negative supply ( $V_{EE}$ ) or the reference supply ( $V_R$ ) can be as much as 36V. To accommodate variations in input logic reference voltages,  $V_R$  can range from  $V_{EE}$  to ( $V_{CC} - 4.5V$ ). Care should be taken to ensure that the power supply leads for the device never become reversed in polarity or that the device is never inadvertently installed backwards in a test socket. If one of these conditions occurs, the supplies would zener an internal diode to an unlimited current; and result in a destroyed device.

### SWITCHING TRANSIENTS

When a switch is turned OFF or ON, transients will appear at the load due to the internal transient voltage at the gate of the switch JFET being coupled to the drain and source by the junction capacitances of the JFET. The magnitude of these transients is dependent on the load. A lower value  $R_L$  produces a lower transient voltage. A negative transient occurs during the delay time ON, while a positive transient occurs during the delay time OFF. These transients are relatively small when compared to faster switch families.

### DISABLE NODE

This node can be used, as shown in Figure 5, to turn all the switches in the unit off independent of logic inputs. Normally, the node floats freely at an internal diode drop ( $\approx 0.7V$ ) above  $V_R$ . When the external transistor in Figure 5 is saturated, the node is pulled very close to  $V_R$  and the unit is disabled. Typically, the current from the node will be less than 1 mA. This feature is not available on the LF11201 or LF11202 series.

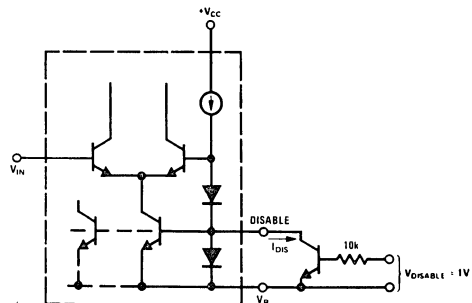
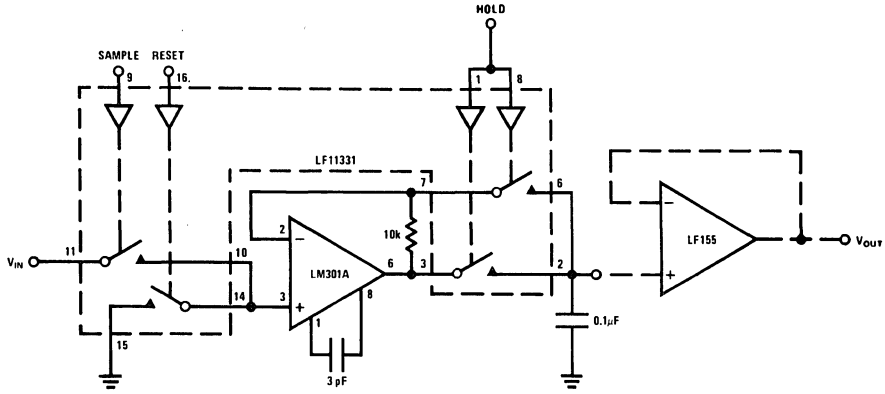

FIGURE 5. Disable Function

TL/H/5667-6

# Typical Applications

## Sample and Hold with Reset



## Programmable Inverting Non-Inverting Operational Amplifier

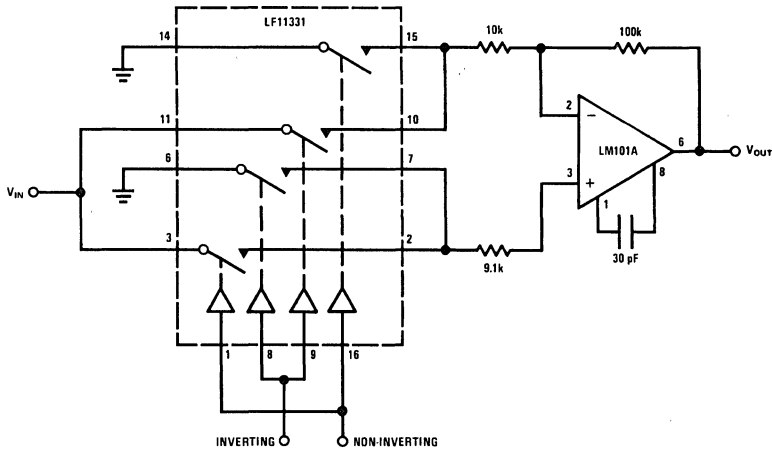

## Programmable Gain Operational Amplifier

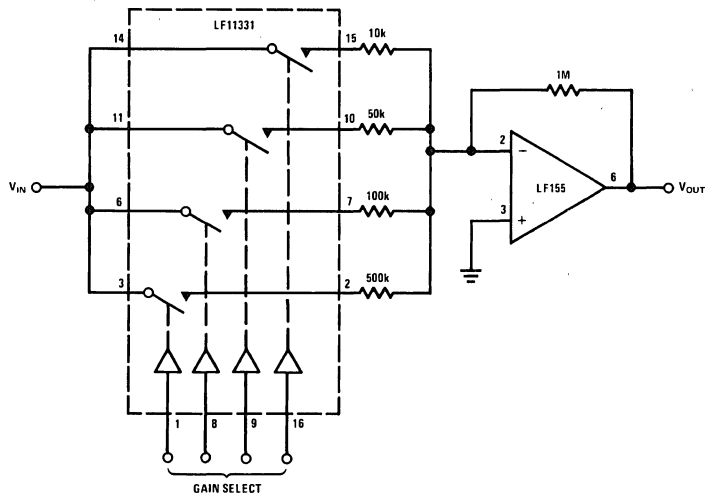





Typical Applications (Continued)

Programmable Integrator with Reset and Hold

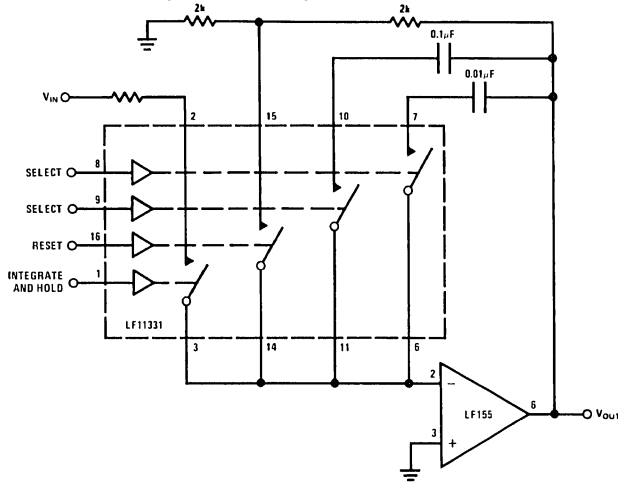

Staircase Transfer Function Operational Amplifier

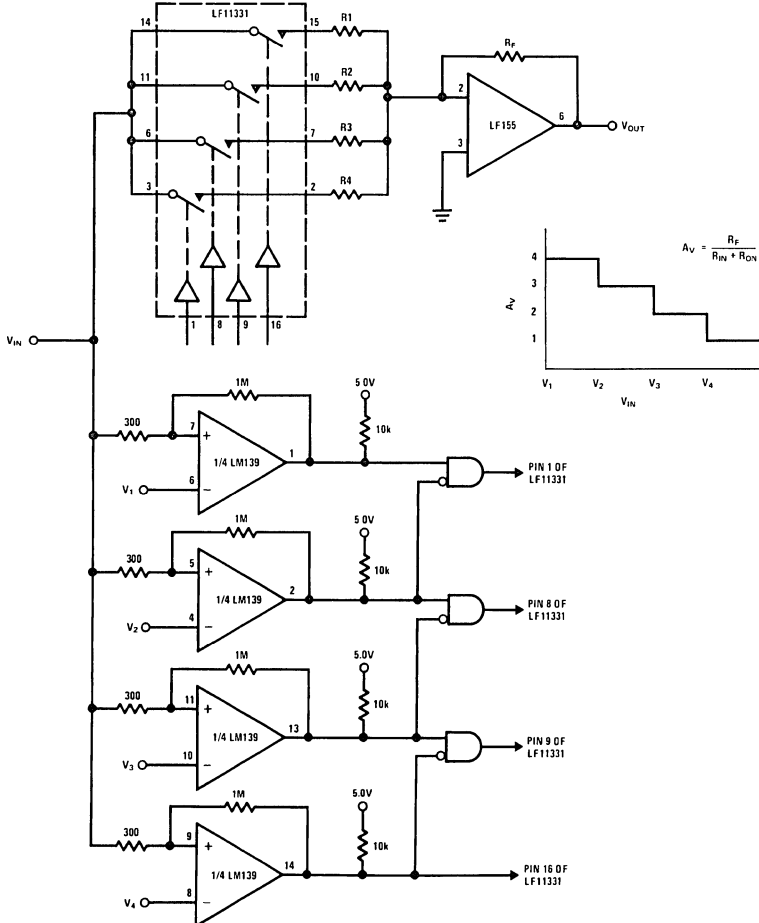

Typical Applications (Continued)

DSB Modulator-Demodulator

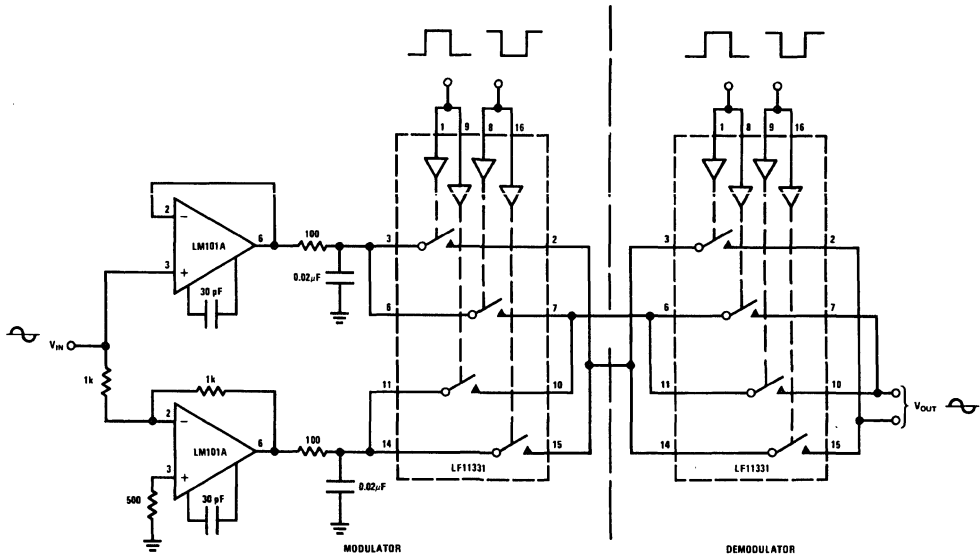

TL/H/5667-11